

.88 [22.2] DIA. KNOCKOUT
(3) PLACES FOR
WIRING CONNECTIONS

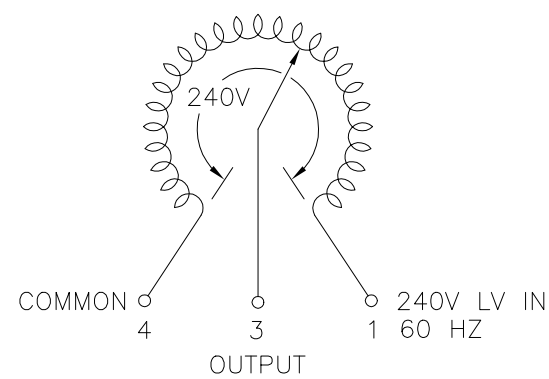
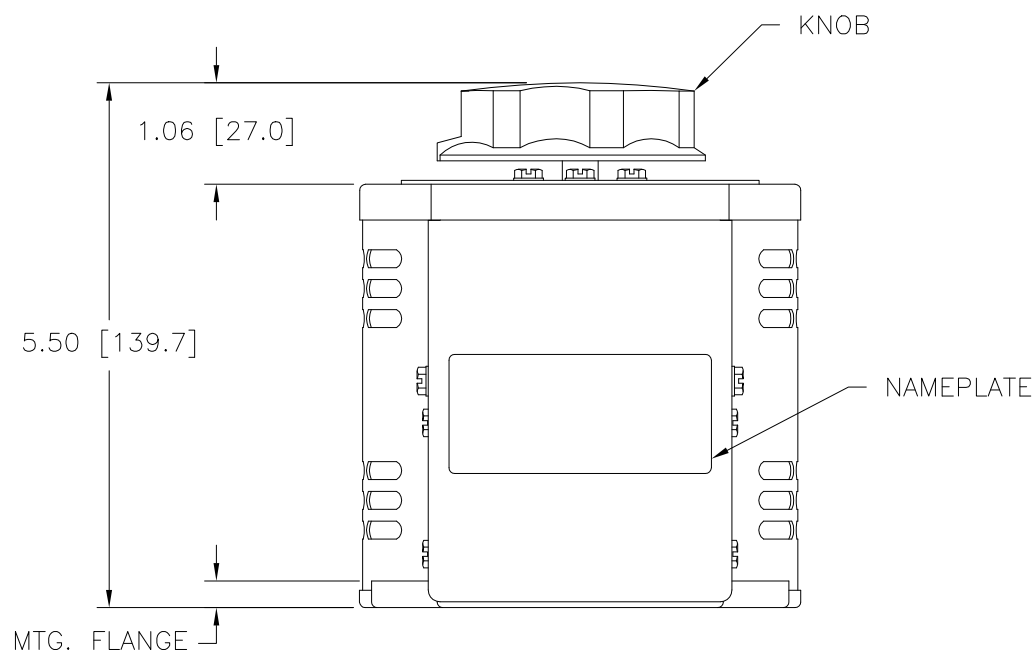

SCHMATIC
VIEW FROM BASE END
FUSE RECOMMENDED BUT NOT SUPPLIED

SPECIFICATIONS											
WIRING	INPUT		OUTPUT				SHAFT ROTATION TO INCREASE VOLTAGE	TERMINAL CONNECTIONS			
	VOLTS	HERTZ	VOLTS	CONSTANT CURRENT LOAD	CONSTANT IMPEDANCE LOAD	FOR INCREASING VOLTAGE AS VIEWED FROM BASE END		INPUT	JUMPER	OUTPUT	
SINGLE PHASE	240	60	0-240	MAX. AMPS	MAX. KVA	MAX. AMPS	MAX. KVA	CW CCW	1-4	1-4	4-3 1-3
				5.0	1.20	7.0	1.68				

UNLESS OTHERWISE SPECIFIED, TOLERANCE IS ±				UNITS		TITLE: SPEC. CONTROL DRAWING					
DECIMALS	HOLES	ANGLES	DRAFT	IN	MM	VARIABLE TRANSFORMER					
.XX	.0000	.06	1°	1-1/2°		MODEL: 1220BCT					
.XXX	.005					DRAWN BY: S.A. SMITH					
MATERIAL:				ALL DIMENSIONS APPLY AFTER PLATING		DATE: 9/26/97		FIRST USED ON:		DO NOT SCALE DWG.	
The information and design disclosed herein was originated by and is the property of STACO ENERGY PRODUCTS CO., which reserves all patent, proprietary, design, manufacturing, reproduction, use and sale rights thereto, and to any article disclosed therein except to the extent rights are expressly granted to others. The foregoing does not apply to vendor proprietary parts.				CHECKER:		DATE:		WEIGHT APPROX. 10.25 LBS		CAGE CODE 83008	
				ENGINEER:		DATE:		SCALE 1=1		SHEET 1 OF 1	



Authorized Distribution Brand :



Website :

Welcome to visit www.ameya360.com

Contact Us :

➤ Address :

401 Building No.5, JiuGe Business Center, Lane 2301, Yishan Rd
Minhang District, Shanghai , China

➤ Sales :

Direct +86 (21) 6401-6692

Email amall@ameya360.com

QQ 800077892

Skype ameyasales1 ameyasales2

➤ Customer Service :

Email service@ameya360.com

➤ Partnership :

Tel +86 (21) 64016692-8333

Email mkt@ameya360.com