



High-Voltage (100V), High-Current (50mA) OPERATIONAL AMPLIFIERS, G = 1 Stable

FEATURES

- **WIDE POWER-SUPPLY RANGE:**
±5V (10V) to ±50V (100V)
- **HIGH OUTPUT LOAD DRIVE:** $I_o > \pm 50\text{mA}$
- **WIDE OUTPUT VOLTAGE SWING:** 1V to Rails
- **INDEPENDENT OUTPUT DISABLE OR SHUTDOWN**
- **WIDE TEMPERATURE RANGE:** –40°C to +85°C
- **SO-8 PACKAGE**

APPLICATIONS

- **TEST EQUIPMENT**
- **AVALANCHE PHOTODIODE:**
High-V Current Sense
- **PIEZOELECTRIC CELLS**
- **TRANSDUCER DRIVERS**
- **SERVO DRIVERS**
- **AUDIO AMPLIFIERS**
- **HIGH-VOLTAGE COMPLIANCE CURRENT SOURCES**
- **GENERAL HIGH-VOLTAGE REGULATORS/POWER**

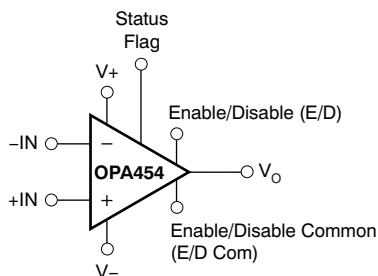

DESCRIPTION

The OPA454 is a low-cost operational amplifier with high voltage (100V) and relatively high current drive (50mA). It is unity-gain stable and has a gain-bandwidth product of 2.5MHz.

The OPA454 is internally protected against over-temperature conditions and current overloads. It is fully specified to perform over a wide power-supply range of ±5V to ±50V or on a single supply of 10V to 100V. The status flag is an open-drain output that allows it to be easily referenced to standard low-voltage logic circuitry. This high-voltage op amp provides excellent accuracy, wide output swing, and is free from phase inversion problems that are often found in similar amplifiers.

The output can be independently disabled using the Enable/Disable Pin that has its own common return pin to allow easy interface to low-voltage logic circuitry. This disable is accomplished without disturbing the input signal path, not only saving power but also protecting the load.

Featured in a small exposed metal pad package, the OPA454 is easy to heatsink over the extended industrial temperature range, –40°C to +85°C.

Table 1. OPA454 RELATED PRODUCTS

PRODUCT	DESCRIPTION
OPA445 ⁽¹⁾	80V, 15mA
OPA452	80V, 50mA
OPA547	60V, 750mA
OPA548	60V, 3A
OPA549	60V, 9A
OPA551	60V, 200mA
OPA567	5V, 2A
OPA569	5V, 2.4A

- (1) The OPA445 is pin-compatible with the OPA454, except in applications using the offset trim, and NC pins other than open.



Please be aware that an important notice concerning availability, standard warranty, and use in critical applications of Texas Instruments semiconductor products and disclaimers thereto appears at the end of this data sheet.

All trademarks are the property of their respective owners.



This integrated circuit can be damaged by ESD. Texas Instruments recommends that all integrated circuits be handled with appropriate precautions. Failure to observe proper handling and installation procedures can cause damage.

ESD damage can range from subtle performance degradation to complete device failure. Precision integrated circuits may be more susceptible to damage because very small parametric changes could cause the device not to meet its published specifications.

ORDERING INFORMATION⁽¹⁾

PRODUCT	PACKAGE-LEAD	PACKAGE DESIGNATOR	PACKAGE MARKING
OPA454	SO-8	DDA	OPA454

(1) For the most current package and ordering information see the Package Option Addendum at the end of this document, or see the TI web site at www.ti.com.

ABSOLUTE MAXIMUM RATINGS⁽¹⁾

		OPA454	UNIT
Supply Voltage	$V_S = (V+) - (V-)$	120	V
Signal Input Terminals, Voltage ⁽²⁾		$(V-) - 0.3$ to $(V+) + 0.3$	V
Signal Input Terminals, Current ⁽²⁾		±10	mA
E/D to E/D Com Voltage		+5.5	V
Output Short-Circuit ⁽³⁾	I_{SC}	Continuous	
Operating Temperature	T_J	-55 to +125	°C
Storage Temperature		-55 to +125	°C
Junction Temperature	T_J	+150	°C
ESD Rating:	Human Body Model (HBM)	4000	V
	Charged Device Model (CDM)	500	V
	Machine Model (MM)	150	V

- (1) Stresses above these ratings may cause permanent damage. Exposure to absolute maximum conditions for extended periods may degrade device reliability. These are stress ratings only, and functional operation of the device at these or any other conditions beyond those specified is not implied.
- (2) Input terminals are diode-clamped to the power-supply rails. Input signals that can swing more than 0.3V beyond the supply rails should be current limited to 10mA or less.
- (3) Short-circuit to ground.

PIN ASSIGNMENT

**DDA PACKAGE
SO-8 PowerPAD
(TOP VIEW)**

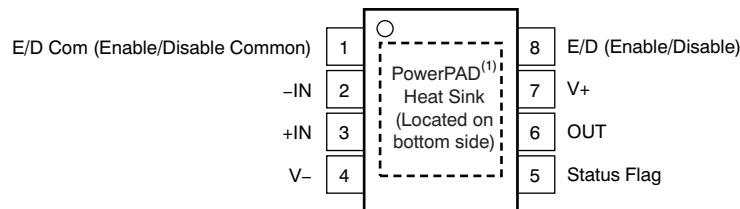

(1) PowerPAD is internally connected to V-. Soldering the PowerPAD to the printed circuit board (PCB) is always required, even with applications that have low power dissipation.

ELECTRICAL CHARACTERISTICS: $V_S = \pm 50V$
Boldface limits apply over the specified temperature range, $T_A = -40^\circ\text{C}$ to $+85^\circ\text{C}$.

 At $T_P^{(1)} = +25^\circ\text{C}$, $R_L = 4.8\text{k}\Omega$ to mid-supply, $V_{CM} = V_{OUT} = \text{mid-supply}$, unless otherwise noted.

PARAMETER	CONDITIONS	OPA454			UNIT	
		MIN	TYP	MAX		
OFFSET VOLTAGE						
Input Offset Voltage vs Temperature ⁽²⁾ vs Power Supply	V_{OS} dV_{OS}/dT PSRR $I_O = 0$ $V_S = \pm 4V$ to $\pm 60V$, $V_{CM} = 0V$		± 0.2 ± 1.6 25	± 4 ± 10 100	mV $\mu\text{V}/^\circ\text{C}$ $\mu\text{V}/V$	
INPUT BIAS CURRENT						
Input Bias Current vs Temperature	I_B		± 1.4	± 100	pA	
Input Offset Current	I_{OS}		± 0.2	± 100	pA	
NOISE						
Input Voltage Noise Density, $f = 10\text{Hz}$	e_n		300		$\text{nV}/\sqrt{\text{Hz}}$	
Input Voltage Noise Density, $f = 10\text{kHz}$			35		$\text{nV}/\sqrt{\text{Hz}}$	
$f = 0.01\text{Hz}$ to 10Hz			15		μV_{PP}	
Current Noise Density, $f = 1\text{kHz}$	i_n		40		$\text{fA}/\sqrt{\text{Hz}}$	
INPUT VOLTAGE RANGE						
Common-Mode Voltage Range	V_{CM}	Linear Operation	$(V-) + 2.5$	See Note ⁽³⁾	$(V+) - 2.5$	V
Common-Mode Rejection	CMRR	$V_S = \pm 50V$, $-25V \leq V_{CM} \leq +25V$	100	146		dB
		$V_S = \pm 50V$, $-45V \leq V_{CM} \leq +45V$	100	147		dB
Over Temperature		$V_S = \pm 50V$, $-25V \leq V_{CM} \leq +25V$	80	88		dB
Over Temperature		$V_S = \pm 50V$, $-45V \leq V_{CM} \leq +45V$	72	82		dB
INPUT IMPEDANCE						
Differential				$10^{13} \parallel 10$		$\Omega \parallel \text{pF}$
Common-Mode				$10^{13} \parallel 9$		$\Omega \parallel \text{pF}$
OPEN-LOOP GAIN						
Open-Loop Voltage Gain ⁽⁴⁾	A_{OL}	$(V-) + 1V < V_O < (V+) - 1V$, $R_L = 49\text{k}\Omega$, $I_O = \pm 1\text{mA}$	100	130		dB
		$(V-) + 1V < V_O < (V+) - 1V$, $R_L = 49\text{k}\Omega$, $I_O = \pm 1\text{mA}$		112		dB
		$(V-) + 1V < V_O < (V+) - 2V$, $R_L = 4.8\text{k}\Omega$, $I_O = \pm 10\text{mA}$	100	115		dB
		$(V-) + 1V < V_O < (V+) - 2V$, $R_L = 4.8\text{k}\Omega$, $I_O = \pm 10\text{mA}$		106		dB
		$(V-) + 2V < V_O < (V+) - 3V$, $R_L = 1880\Omega$, $I_O = \pm 25\text{mA}$	80	102		dB
		$(V-) + 2V < V_O < (V+) - 3V$, $R_L = 1880\Omega$, $I_O = \pm 25\text{mA}$		84		dB

 (1) T_P is the temperature of the leadframe die pad (exposed thermal pad) of the PowerPAD package.

 (2) See typical characteristic curve, *Offset Voltage Drift Production Distribution* (Figure 14).

 (3) Typical range is $(V-) + 1.5V$ to $(V+) - 1.5V$.

 (4) Measured using low-frequency ($< 10\text{Hz}$) $\pm 49V$ square wave. See typical characteristic curve, *Current Limit vs Temperature* (Figure 24).

ELECTRICAL CHARACTERISTICS: $V_S = \pm 50V$ (continued)

Boldface limits apply over the specified temperature range, $T_A = -40^\circ\text{C}$ to $+85^\circ\text{C}$.

At $T_P = +25^\circ\text{C}$, $R_L = 4.8\text{k}\Omega$ to mid-supply, $V_{CM} = V_{OUT} = \text{mid-supply}$, unless otherwise noted.

PARAMETER	CONDITIONS	OPA454			UNIT	
		MIN	TYP	MAX		
FREQUENCY RESPONSE⁽⁵⁾						
Gain-Bandwidth Product	GBW	Small-Signal			MHz	
Slew Rate	SR	$G = \pm 1$, $V_O = 80V$ Step, $R_L = 3.27\text{k}\Omega$			$V/\mu\text{s}$	
Full-Power Bandwidth ⁽⁶⁾					kHz	
Settling Time: $\pm 0.1\%$ ⁽⁷⁾		$G = \pm 1$, $V_O = 20V$ Step			μs	
Settling Time: $\pm 0.01\%$ ⁽⁷⁾		$G = \pm 5$ or ± 10 , $V_O = 80V$ Step			μs	
Total Harmonic Distortion + Noise ⁽⁸⁾	THD+N	$V_S = +40.6V/-39.6V$, $G = \pm 1$, $f = 1\text{kHz}$, $V_O = 77.2V_{PP}$			%	
OUTPUT						
Voltage Output Swing From Rail ⁽⁹⁾	V_O	$R_L = 49\text{k}\Omega$, $A_{OL} \geq 100\text{dB}$, $I_O = 1\text{mA}$	$(V-) + 1$		$(V+) - 1$	V
		$R_L = 4.8\text{k}\Omega$, $A_{OL} \geq 100\text{dB}$, $I_O = 10\text{mA}$	$(V-) + 1$		$(V+) - 2$	V
		$R_L = 1880\Omega$, $A_{OL} \geq 80\text{dB}$, $I_O = 26\text{mA}$	$(V-) + 2$		$(V+) - 3$	V
Continuous Current Output, dc		Depends on Circuit Conditions				
Maximum Peak Current Output, Current Limit ⁽¹⁰⁾	I_O			See Figure 6		mA
Over Temperature				+120/-150		mA
Capacitive Load Drive ⁽⁵⁾	C_{LOAD}			200		pF
Open-Loop Output Impedance	R_O			See Figure 5		Ω
Output Disabled						
Output Capacitance				18		pF
Feedthrough Capacitance ⁽¹¹⁾				150		fF
STATUS FLAG PIN (Referenced to E/D Com)⁽¹²⁾						
Status Flag Delay		Enable \rightarrow Disable		6		μs
		Disable \rightarrow Enable		4		μs
		Over-Current Delay ⁽¹³⁾		15		μs
		Over-Current Recovery Delay ⁽¹³⁾		10		μs
Junction Temperature	T_J					
Alarm (status flag high)				+150		$^\circ\text{C}$
Return to Normal Operation (status flag low)				+130		$^\circ\text{C}$
Output Voltage ⁽⁵⁾		Normal Operation			E/D Com + 2	V
		$R_L = 100\Omega$ During Thermal Overdrive, Alarm	$(V+) - 2.5$			V

(5) See [Typical Characteristic](#) curves.

(6) See typical characteristic curve, *Maximum Output Voltage vs Frequency* ([Figure 12](#)).

(7) See the Applications Information section, [Settling Time](#).

(8) Supplies reduced to allow closer swing to rails due to test equipment limitations. See typical characteristic curve *Total Harmonic Distortion + Noise vs Temperature* ([Figure 30](#) and [Figure 31](#)) for additional power levels.

(9) See typical characteristic curve, *Output Voltage Swing vs Output Current* ([Figure 11](#)).

(10) Measured using low-frequency (<10Hz) $\pm 49V$ square wave. See typical characteristic curve, *Current Limit vs Temperature* ([Figure 24](#)).

(11) Measured using [Figure 1](#).

(12) 100k Ω pull-up resistor to (V+). E/D common to (V-). Status flag indicates an over temperature or over-current condition.

(13) See [Typical Characteristic](#) curves for current limit behavior.

ELECTRICAL CHARACTERISTICS: $V_S = \pm 50V$ (continued)
Boldface limits apply over the specified temperature range, $T_A = -40^\circ\text{C}$ to $+85^\circ\text{C}$.

 At $T_P = +25^\circ\text{C}$, $R_L = 4.8\text{k}\Omega$ to mid-supply, $V_{CM} = V_{OUT} = \text{mid-supply}$, unless otherwise noted.

PARAMETER	CONDITIONS	OPA454			UNIT
		MIN	TYP	MAX	
E/D (ENABLE/DISABLE) PIN					
E/D Pin, Referenced to E/D Com Pin ⁽¹⁴⁾ ⁽¹⁵⁾					
High (output enabled)	V_{SD} Pin Open or Forced High	E/D Com + 2.5		E/D Com + 5	V
Low (output disabled)	V_{SD} Pin Forced Low	E/D Com		E/D Com + 0.65	V
Output Disable Time			4		μs
Output Enable Time			3		μs
E/D COM PIN					
Voltage Range		(V–)		(V+) – 5	V
POWER SUPPLY					
Specified Range	V_S		± 50		V
Operating Voltage Range		± 5		± 50	V
Quiescent Current	I_Q $I_O = 0$		3.2	4	mA
Quiescent Current in Shutdown Mode	$I_O = 0, V_{E/D} = 0.65V$		150	210	μA
TEMPERATURE RANGE					
Specified Range	T_A	–40		+85	$^\circ\text{C}$
Operating Range	T_A	–55		+125	$^\circ\text{C}$
Thermal Resistance, Junction-to-Case ⁽¹⁶⁾					
SO-8 PowerPAD ⁽¹⁷⁾	θ_{JC}		10		$^\circ\text{C}/\text{W}$
Thermal Resistance, Junction-to-Ambient	θ_{JA}				
SO-8 PowerPAD ⁽¹⁷⁾			24/52		$^\circ\text{C}/\text{W}$

 (14) See typical characteristic curve, I_{ENABLE} vs V_{ENABLE} (Figure 46).

(15) High enables the outputs.

 (16) T_P is the temperature of the leadframe die pad (exposed thermal pad) of the PowerPAD package.

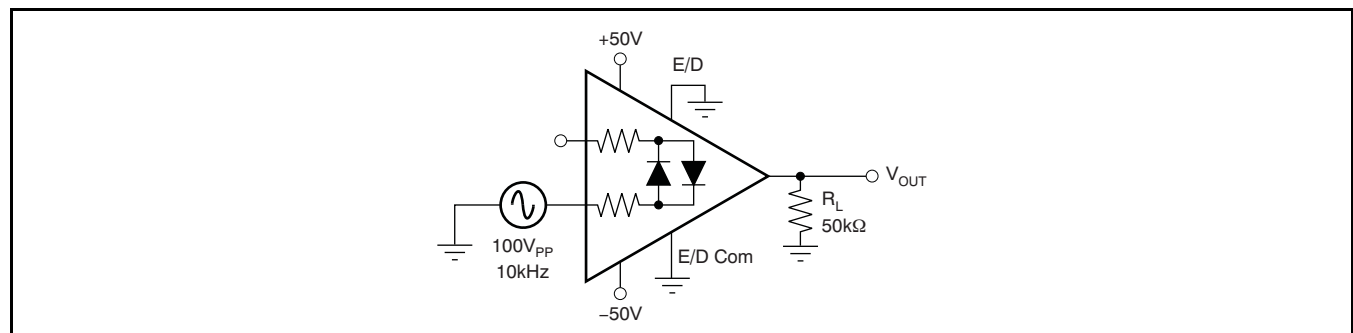
 (17) Lower value is for land area of 1-inch \times 1-inch, 2-oz copper. Upper value is for exposed-pad sized area of 1-oz copper.

Figure 1. Feedthrough Capacitance Circuit

TYPICAL CHARACTERISTICS

At $T_p = +25^\circ\text{C}$, $V_S = \pm 50\text{V}$, and $R_L = 4.8\text{k}\Omega$ connected to GND, unless otherwise noted.

OPEN-LOOP GAIN AND PHASE vs FREQUENCY

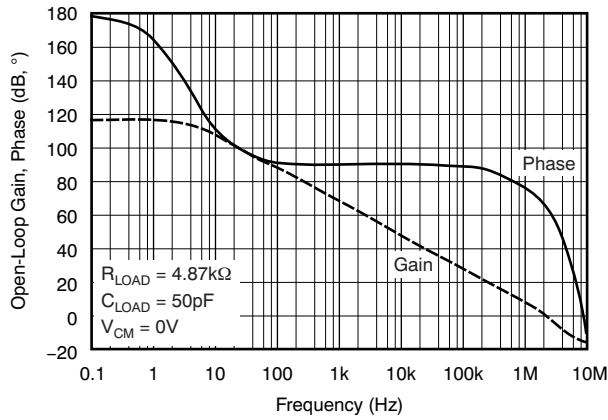

Figure 2.

PHASE MARGIN vs TEMPERATURE

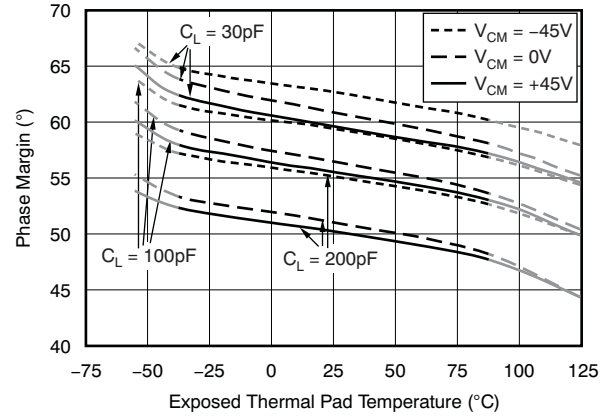

Figure 3.

UNITY-GAIN BANDWIDTH vs TEMPERATURE

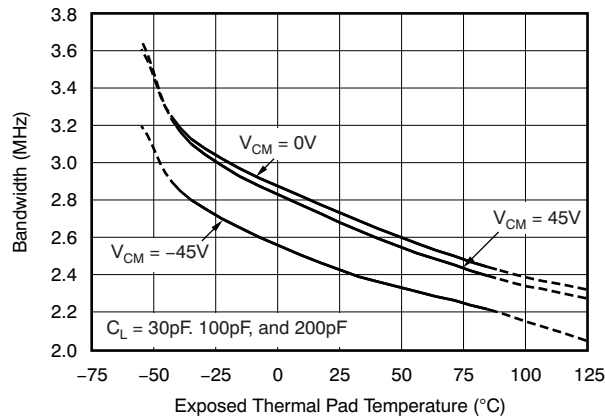

Figure 4.

OPEN-LOOP OUTPUT IMPEDANCE vs FREQUENCY

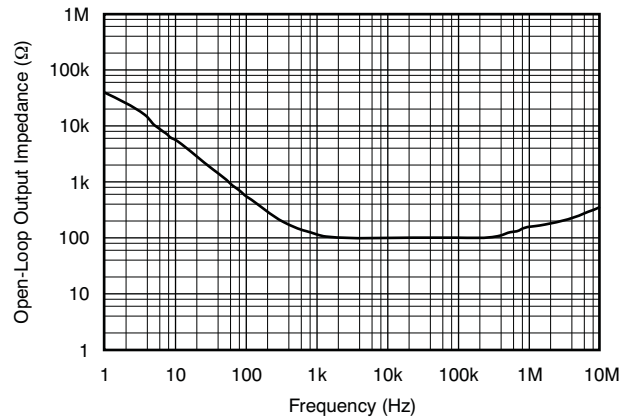

Figure 5.

OPEN-LOOP GAIN vs PEAK-LOAD CURRENT

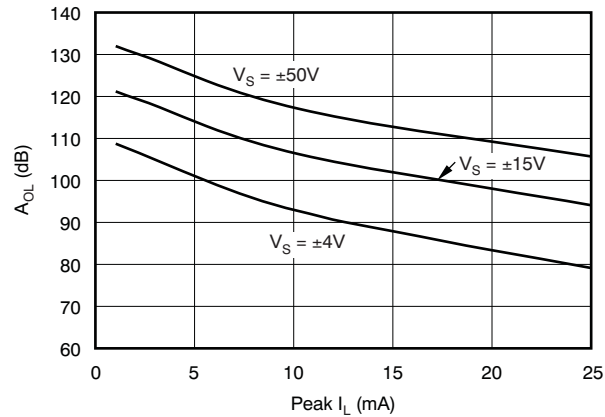

Figure 6.

OPEN-LOOP GAIN vs TEMPERATURE

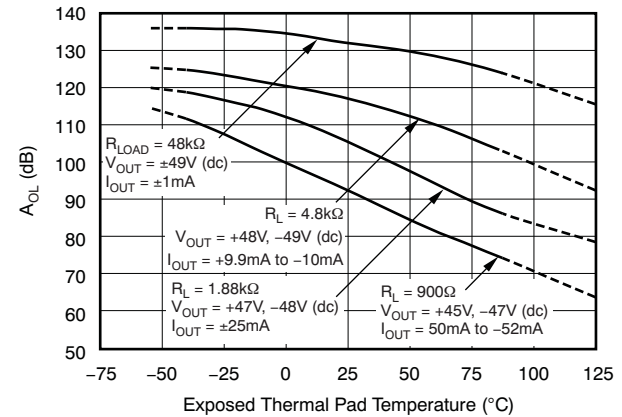

Figure 7.

TYPICAL CHARACTERISTICS (continued)

At $T_p = +25^\circ\text{C}$, $V_S = \pm 50\text{V}$, and $R_L = 4.8\text{k}\Omega$ connected to GND, unless otherwise noted.

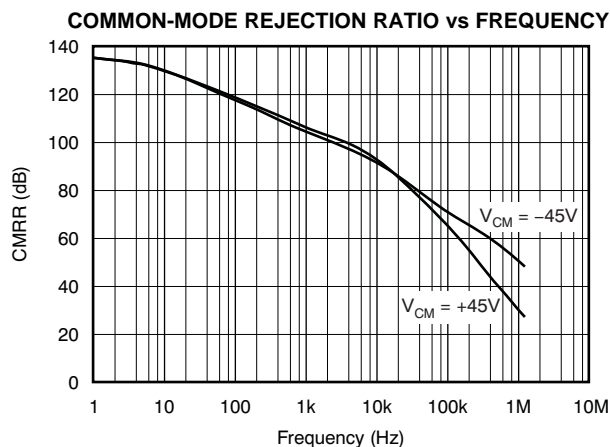

Figure 8.

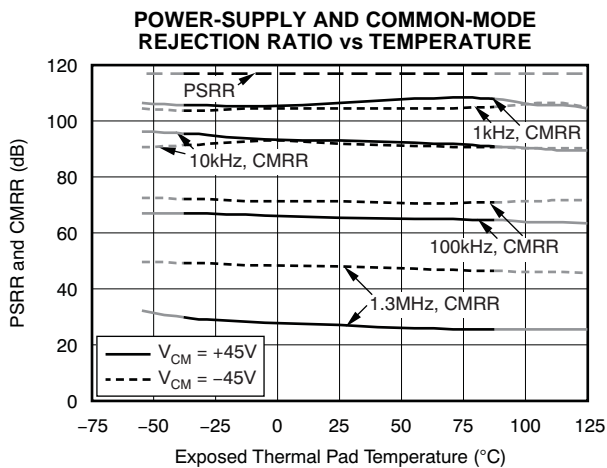

Figure 9.

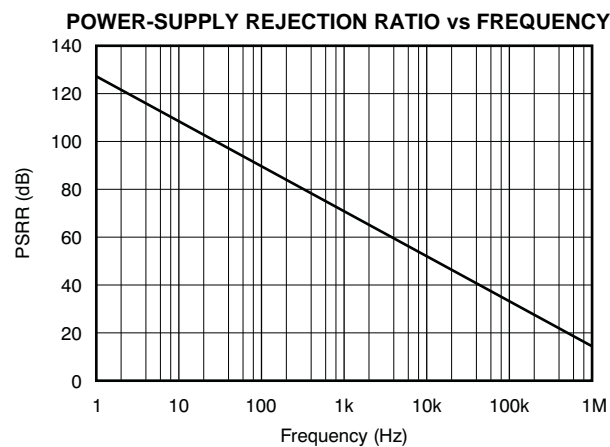

Figure 10.

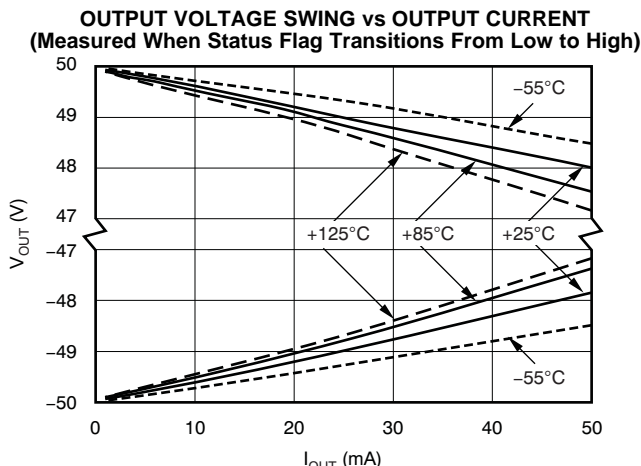

Figure 11.

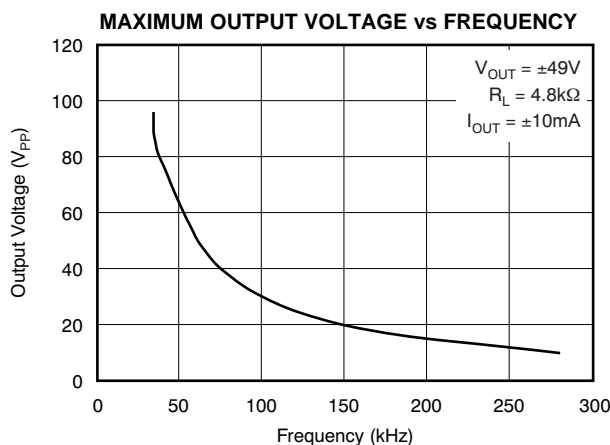

Figure 12.

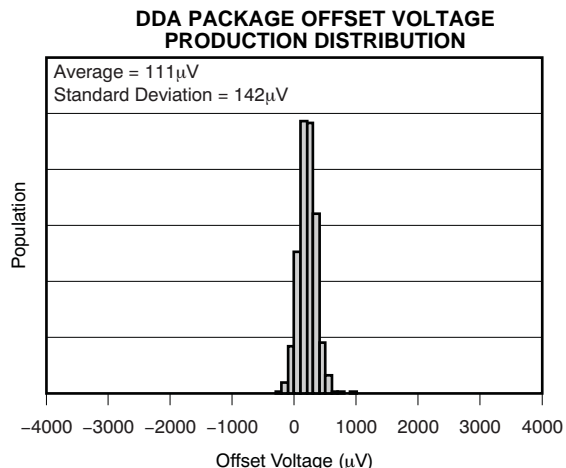

Figure 13.

TYPICAL CHARACTERISTICS (continued)

At $T_P = +25^\circ\text{C}$, $V_S = \pm 50\text{V}$, and $R_L = 4.8\text{k}\Omega$ connected to GND, unless otherwise noted.

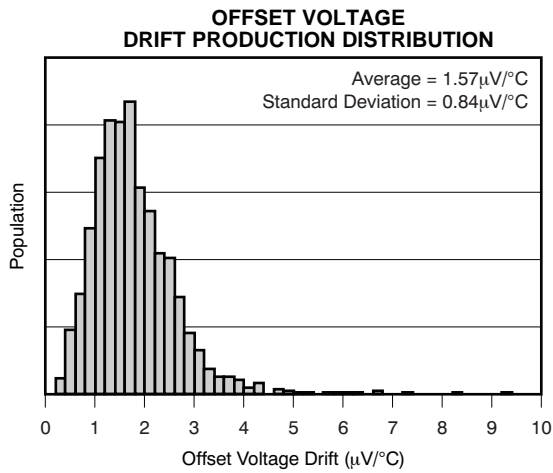

Figure 14.

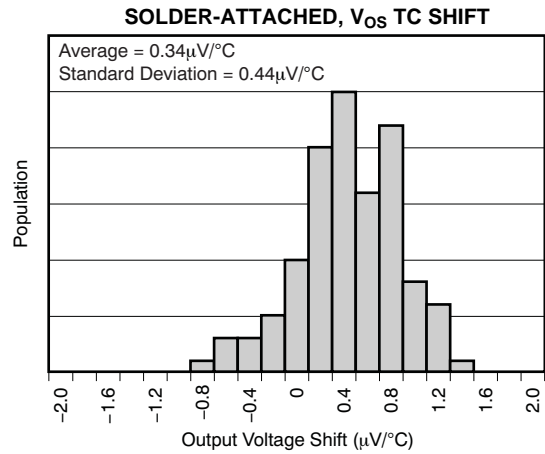

Figure 15.

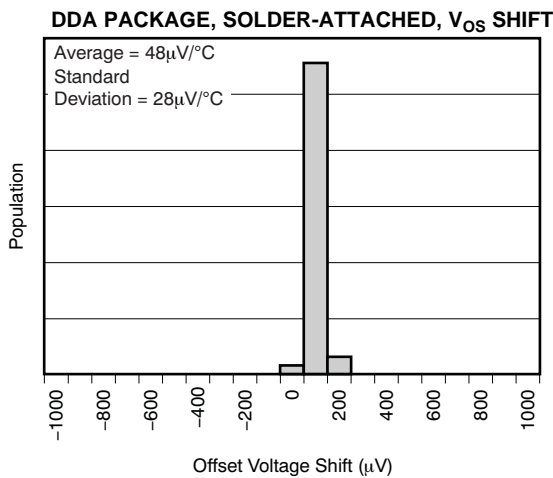

Figure 16.

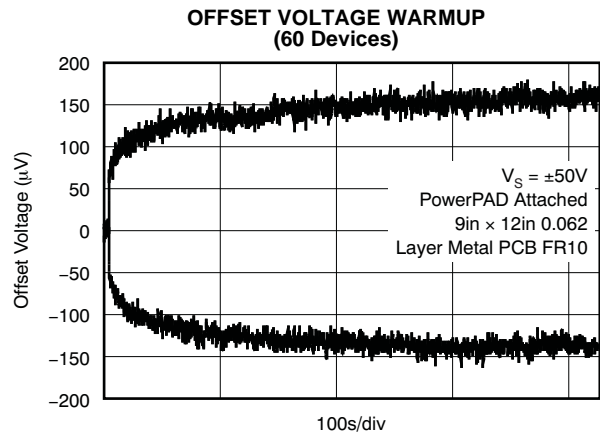

Figure 17.

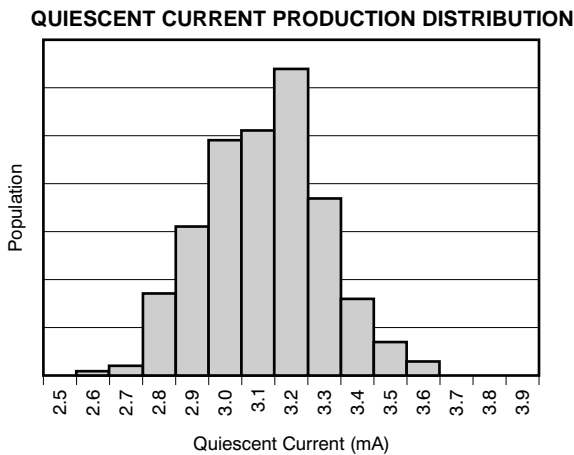

Figure 18.

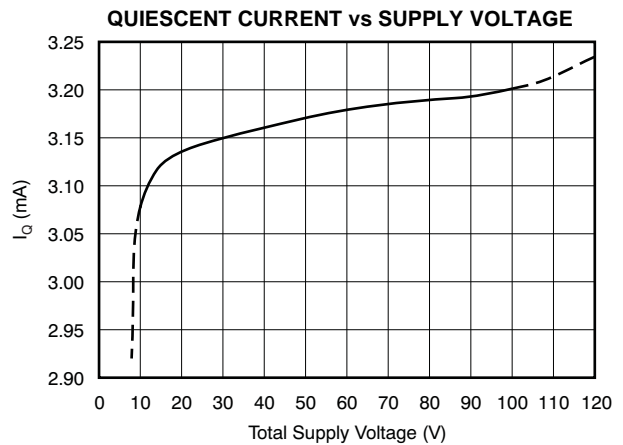

Figure 19.

TYPICAL CHARACTERISTICS (continued)

At $T_P = +25^\circ\text{C}$, $V_S = \pm 50\text{V}$, and $R_L = 4.8\text{k}\Omega$ connected to GND, unless otherwise noted.

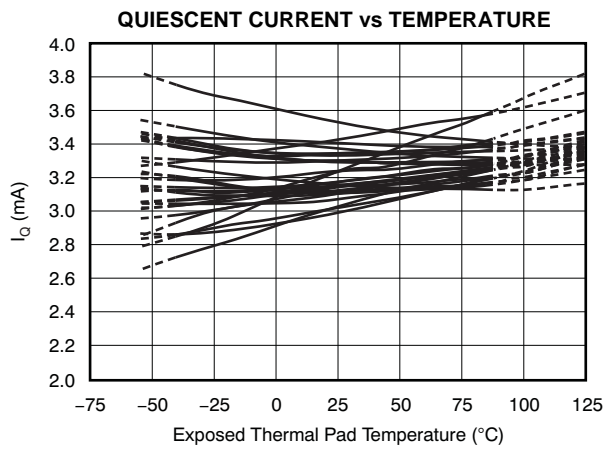

Figure 20.

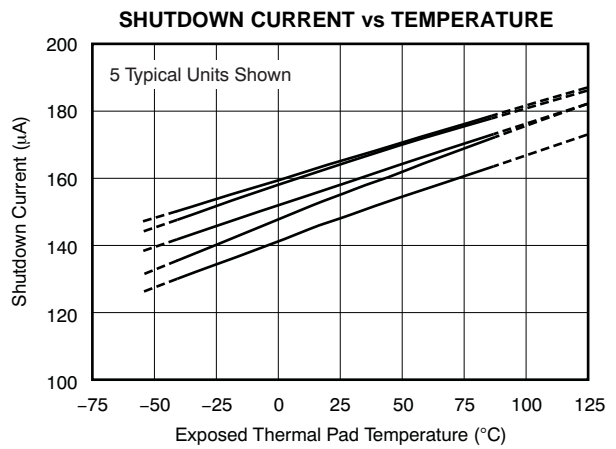

Figure 21.

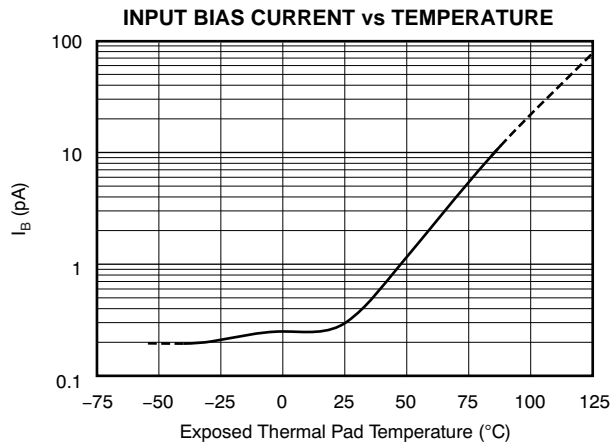

Figure 22.

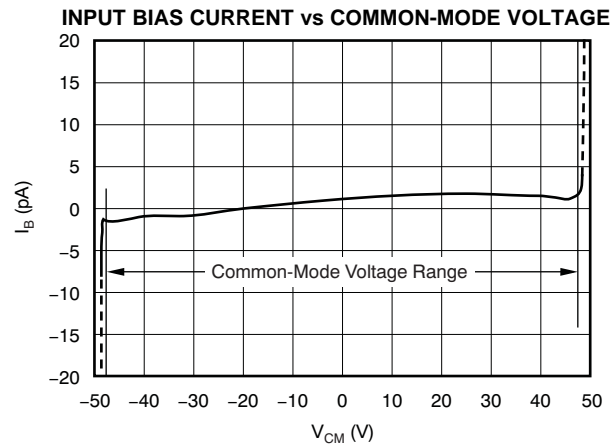

Figure 23.

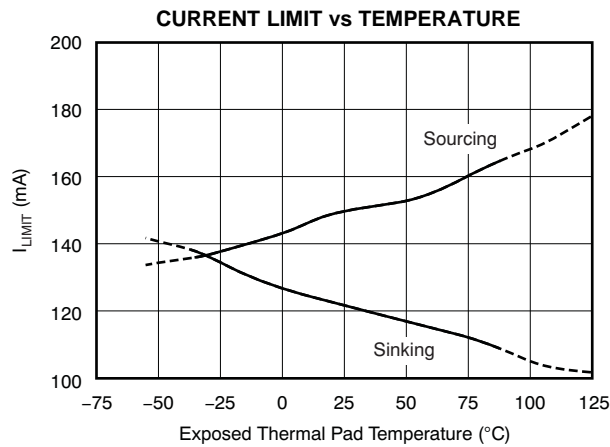

Figure 24.

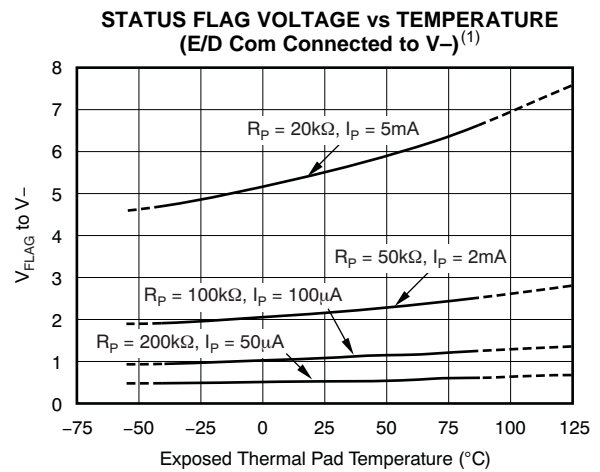

Figure 25.

(1) See Figure 57 in the Applications Information section.

TYPICAL CHARACTERISTICS (continued)

At $T_P = +25^\circ\text{C}$, $V_S = \pm 50\text{V}$, and $R_L = 4.8\text{k}\Omega$ connected to GND, unless otherwise noted.

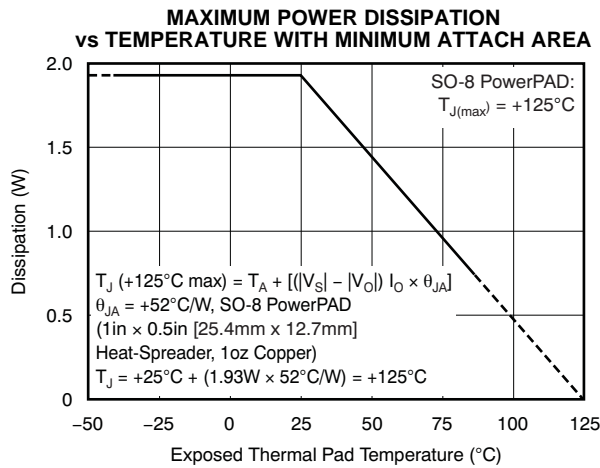

Figure 26.

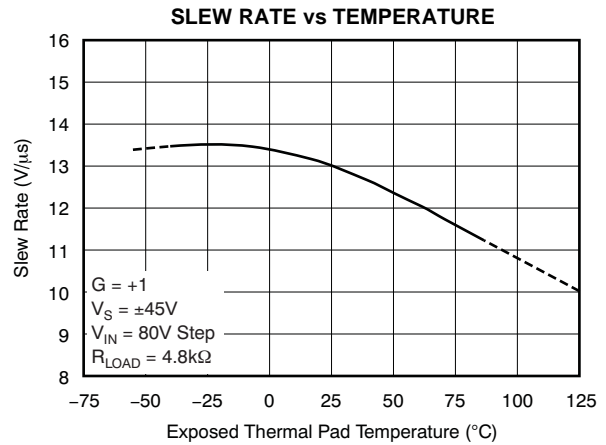

Figure 27.

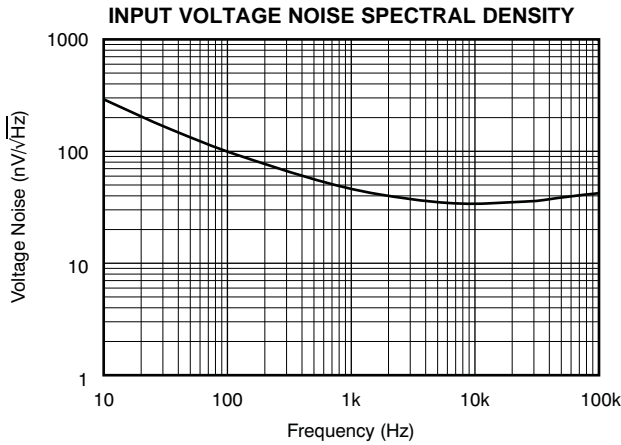

Figure 28.

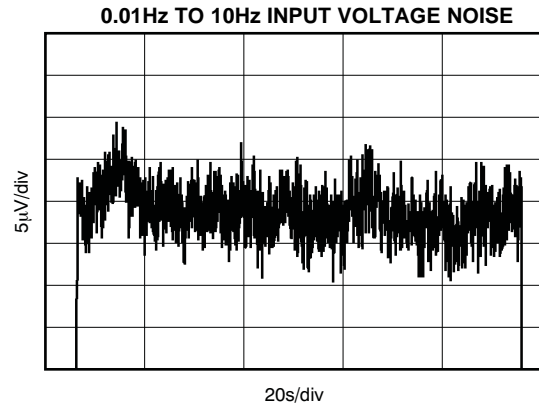

Figure 29.

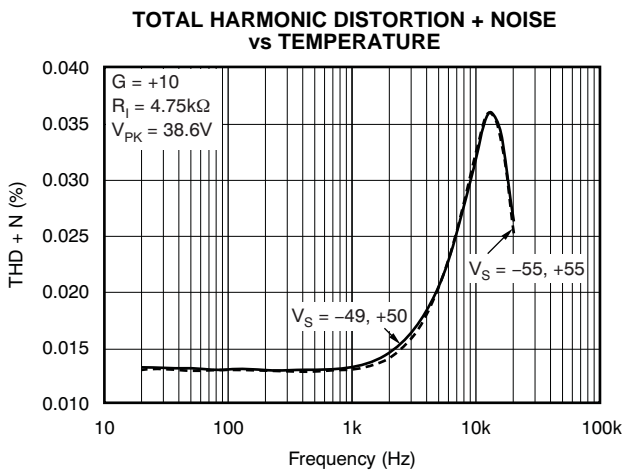

Figure 30.

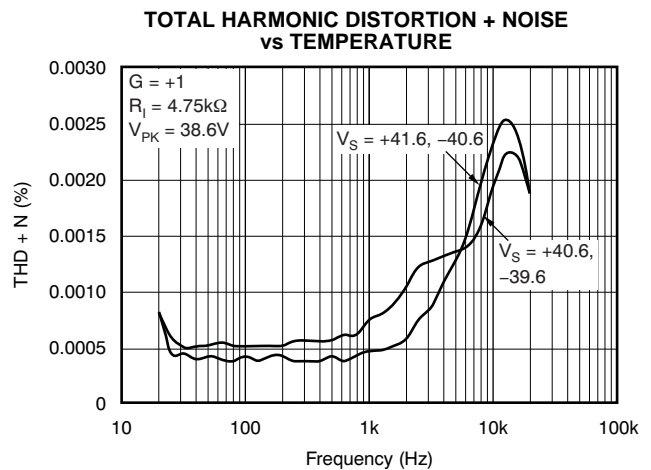

Figure 31.

TYPICAL CHARACTERISTICS (continued)

At $T_p = +25^\circ\text{C}$, $V_S = \pm 50\text{V}$, and $R_L = 4.8\text{k}\Omega$ connected to GND, unless otherwise noted.

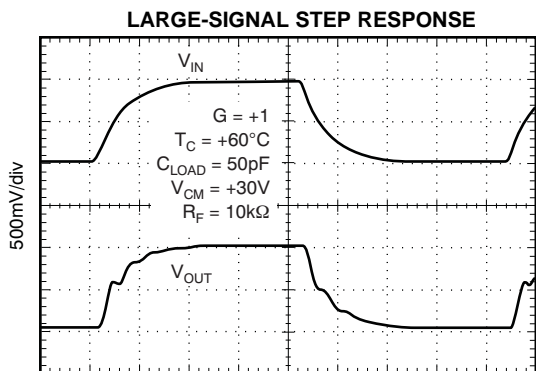

Figure 32.

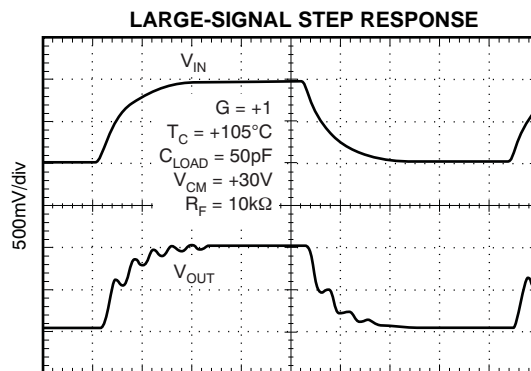

Figure 33.

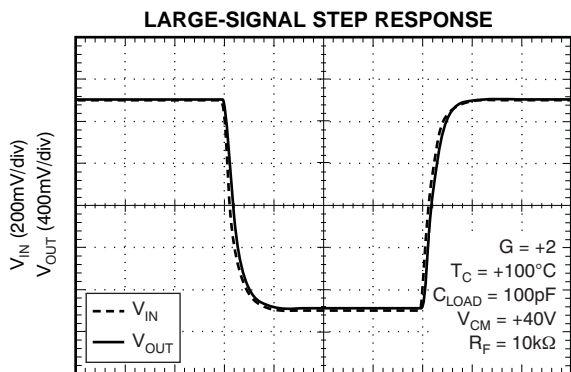

Figure 34.

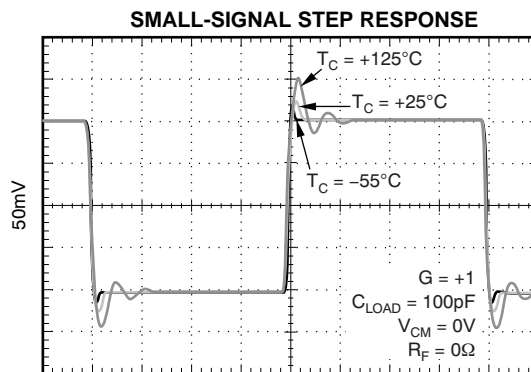

Figure 35.

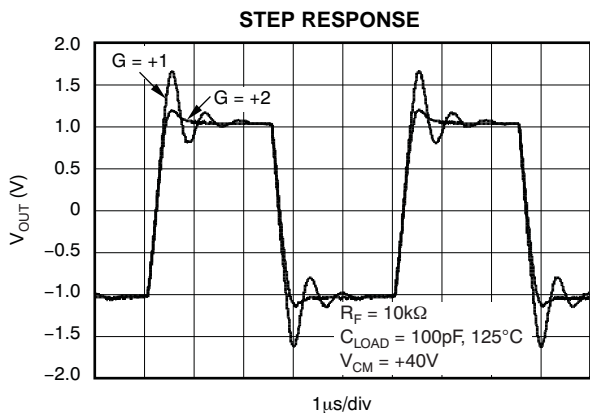

Figure 36.

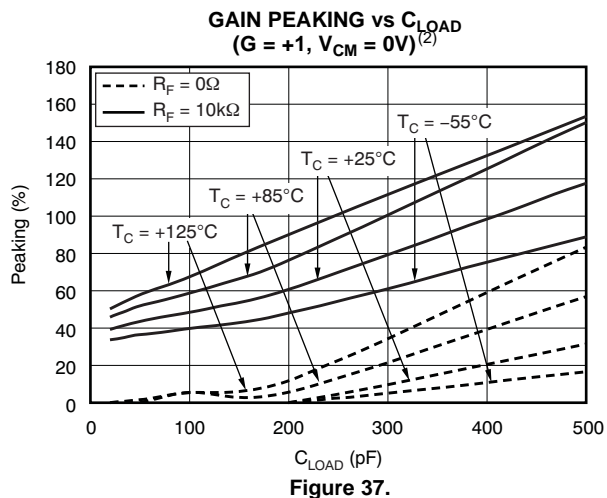

Figure 37.

(2) See Application section, *Unity-Gain Noninverting Configuration*.

TYPICAL CHARACTERISTICS (continued)

At $T_P = +25^\circ\text{C}$, $V_S = \pm 50\text{V}$, and $R_L = 4.8\text{k}\Omega$ connected to GND, unless otherwise noted.

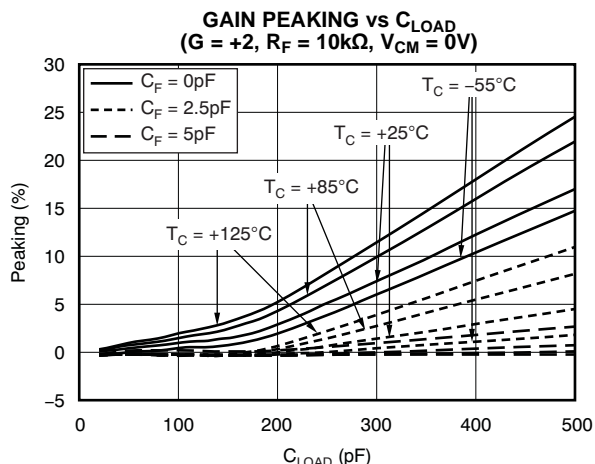

Figure 38.

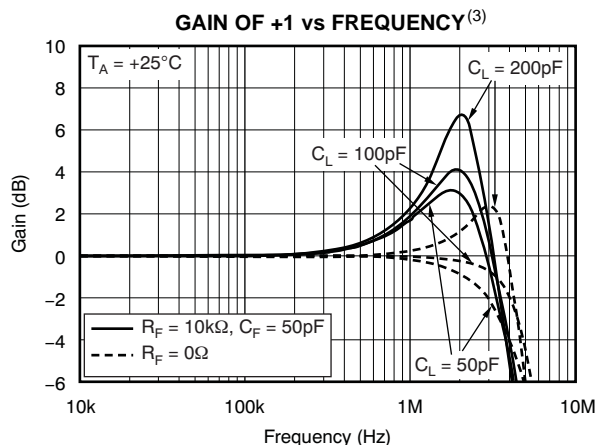

Figure 39.

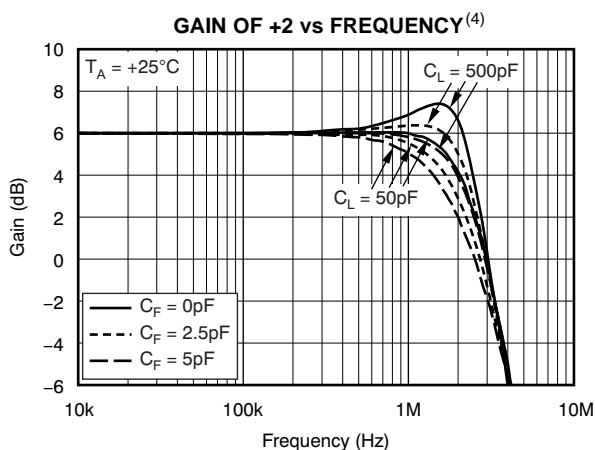

Figure 40.

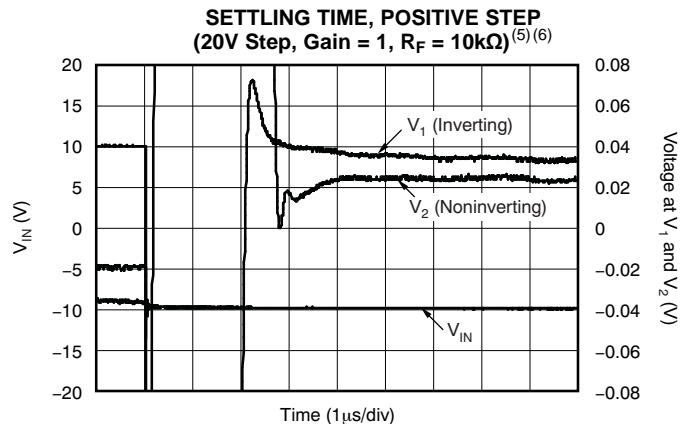

Figure 41.

(3) See Application section [Unity-Gain Noninverting Configuration](#).
 (4) See Application section [Unity-Gain Noninverting Configuration](#).
 (5) See the [Settling Time](#) section.
 (6) The grid for voltage at V_1 and V_2 is scaled 20mV or 0.1% per division.

TYPICAL CHARACTERISTICS (continued)

At $T_p = +25^\circ\text{C}$, $V_S = \pm 50\text{V}$, and $R_L = 4.8\text{k}\Omega$ connected to GND, unless otherwise noted.

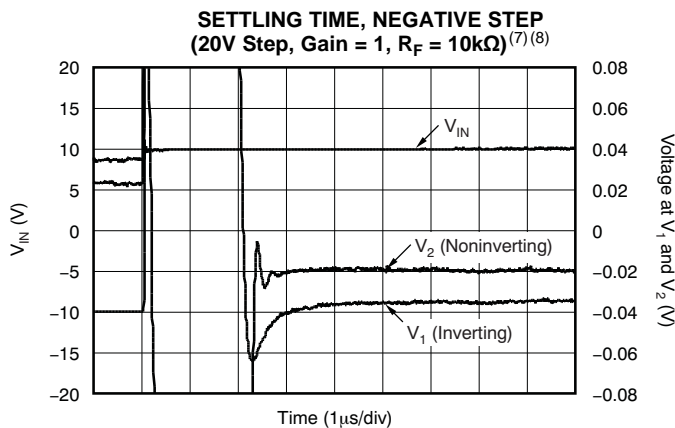

Figure 42.

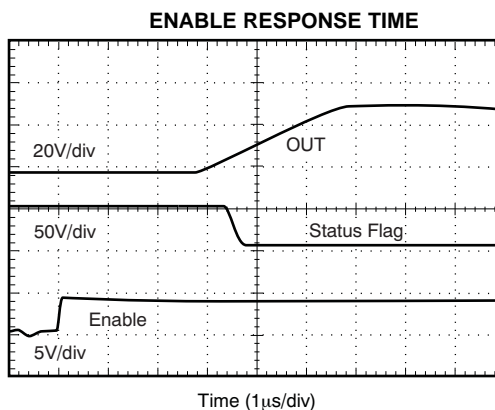

Figure 43.

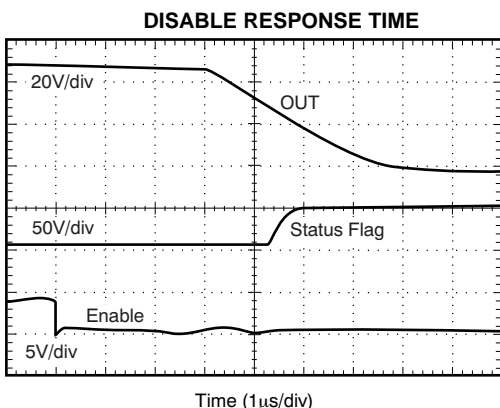

Figure 44.

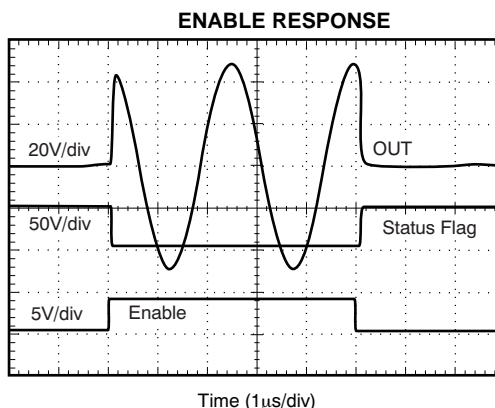

Figure 45.

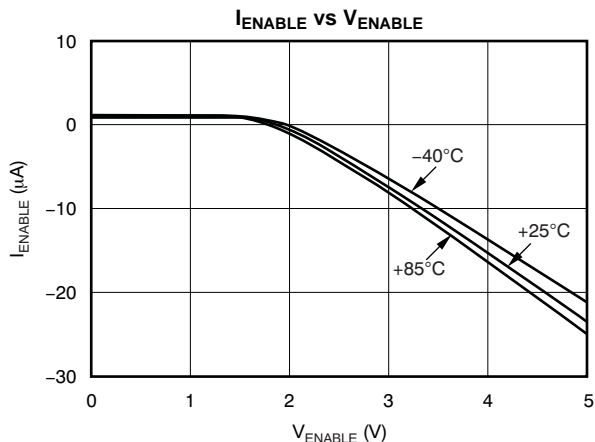

Figure 46.

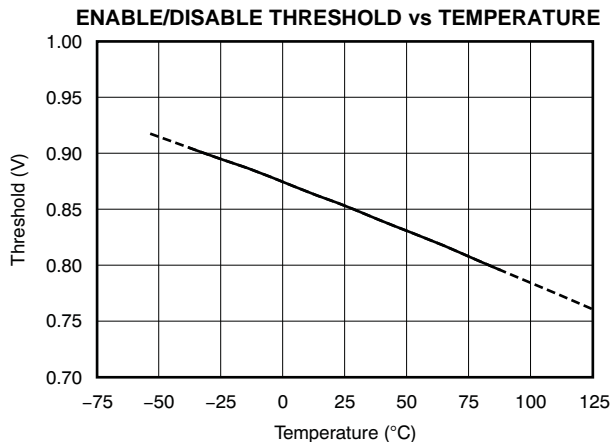

Figure 47.

(7) See the [Settling Time](#) section.

(8) The grid for voltage at V_1 and V_2 is scaled 20mV or 0.1% per division.

TYPICAL CHARACTERISTICS (continued)

At $T_P = +25^\circ\text{C}$, $V_S = \pm 50\text{V}$, and $R_L = 4.8\text{k}\Omega$ connected to GND, unless otherwise noted.

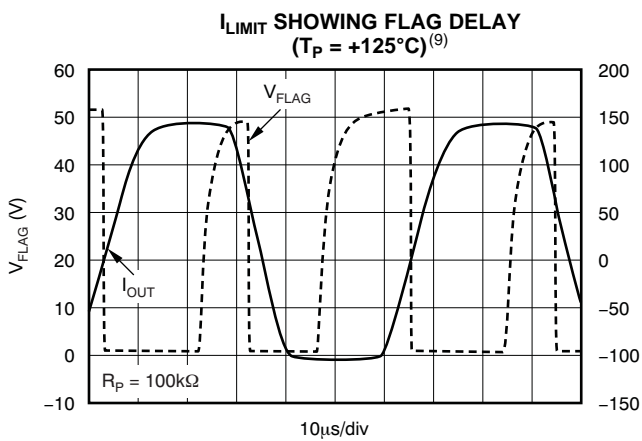

Figure 48.

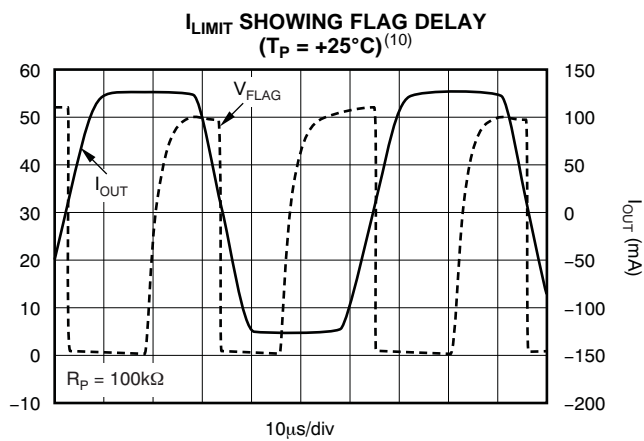

Figure 49.

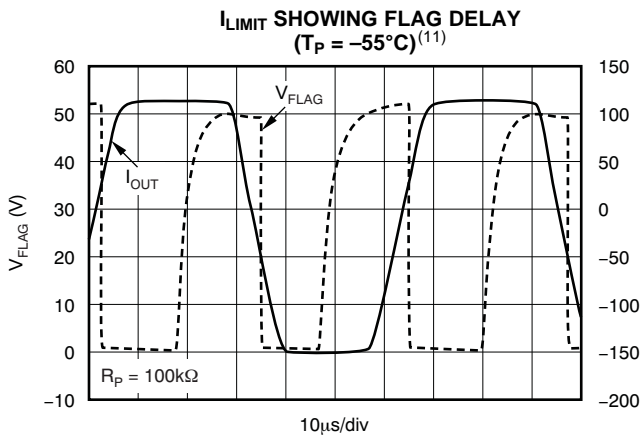

Figure 50.

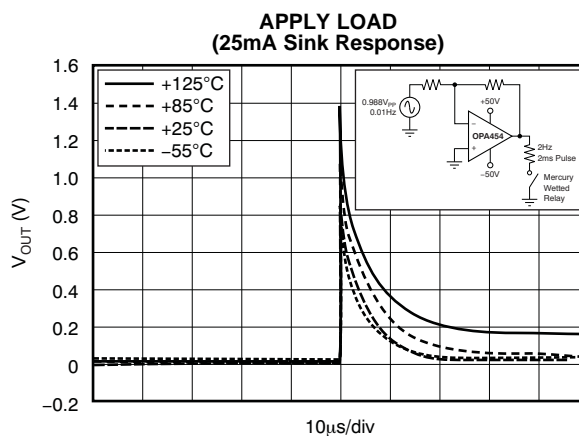

Figure 51.

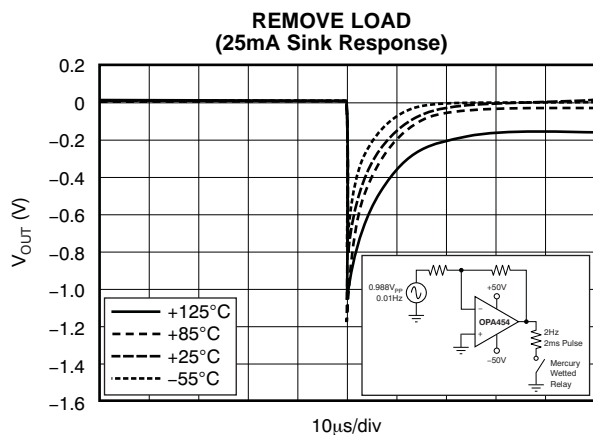

Figure 52.

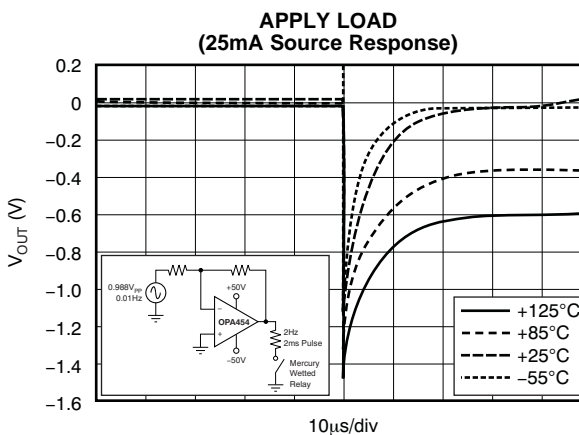

Figure 53.

(9) The OPA454 was connected to sufficient heatsinking to prevent thermal shutdown.

(10) The OPA454 was connected to sufficient heatsinking to prevent thermal shutdown.

(11) The OPA454 was connected to sufficient heatsinking to prevent thermal shutdown.

TYPICAL CHARACTERISTICS (continued)

At $T_P = +25^\circ\text{C}$, $V_S = \pm 50\text{V}$, and $R_L = 4.8\text{k}\Omega$ connected to GND, unless otherwise noted.

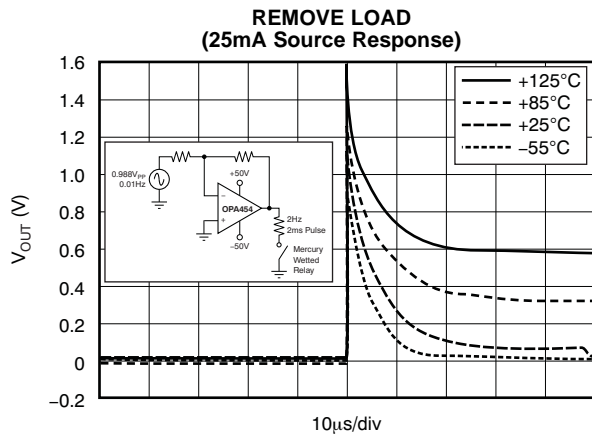

Figure 54.

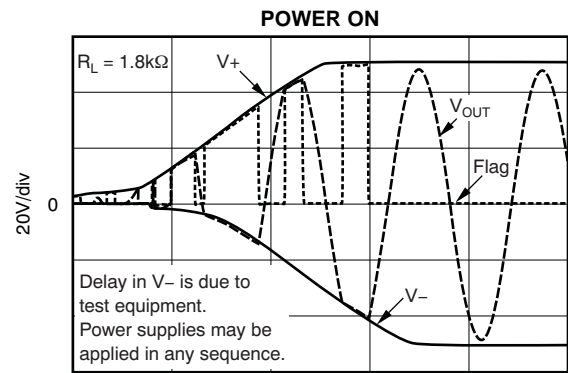

Figure 55.

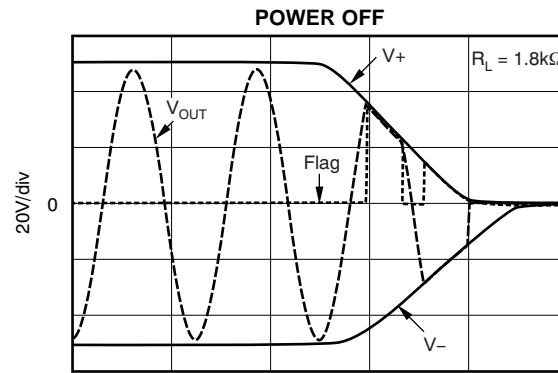
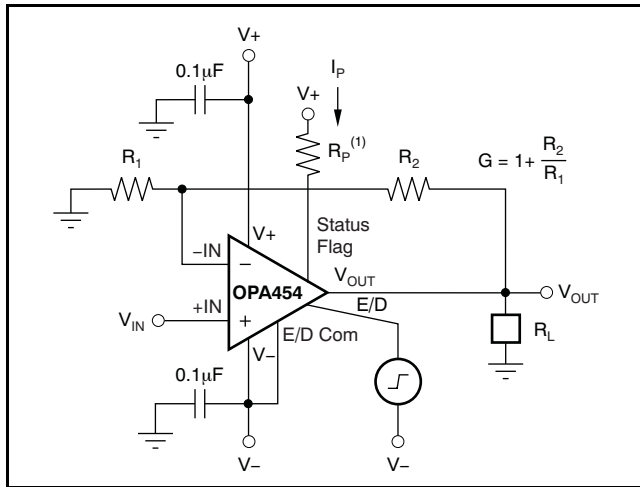

Figure 56.

APPLICATIONS INFORMATION

Figure 57 shows the OPA454 connected as a basic noninverting amplifier. The OPA454 can be used in virtually any $\pm 5V$ to $\pm 50V$ op amp configuration. It is especially useful for supply voltages greater than 36V.

Power-supply terminals should be bypassed with 0.1 μF (or greater) capacitors, located near the power-supply pins. Be sure that the capacitors are appropriately rated for the power-supply voltage used.



(1) Pull-up resistor with at least 10 μA (choose $R_p = 1M\Omega$ with $V_+ = 50V$ for $I_p = 50\mu A$).

Figure 57. Basic Noninverting Amplifier Configuration

POWER SUPPLIES

The OPA454 may be operated from power supplies up to $\pm 50V$ or a total of 100V with excellent performance. Most behavior remains unchanged throughout the full operating voltage range. Parameters that vary significantly with operating voltage are shown in the [Typical Characteristics](#).

Some applications do not require equal positive and negative output voltage swing. Power-supply voltages do not need to be equal. The OPA454 can operate with as little as 10V between the supplies and with up to 100V between the supplies. For example, the positive supply could be set to 90V with the negative supply at $-10V$, or vice-versa (as long as the total is less than or equal to 100V).

INPUT PROTECTION

The OPA454 has increased protection against damage caused by excessive voltage between op amp input pins or input pin voltages that exceed the power supplies; external series resistance is not needed for protection. Internal series JFETs limit input overload current to a non-destructive 4mA, even with an input differential voltage as large as 120V. Additionally, the OPA454 has dielectric isolation between devices and the substrate. Therefore, the amplifier is free from the limitations of junction isolation common to many IC fabrication processes.

LOWERING OFFSET VOLTAGE AND DRIFT

The OPA454 can be used with an [OPA735](#) zero-drift series op amp to create a high-voltage op amp circuit that has very low input offset temperature drift. This circuit is shown in [Figure 58](#).

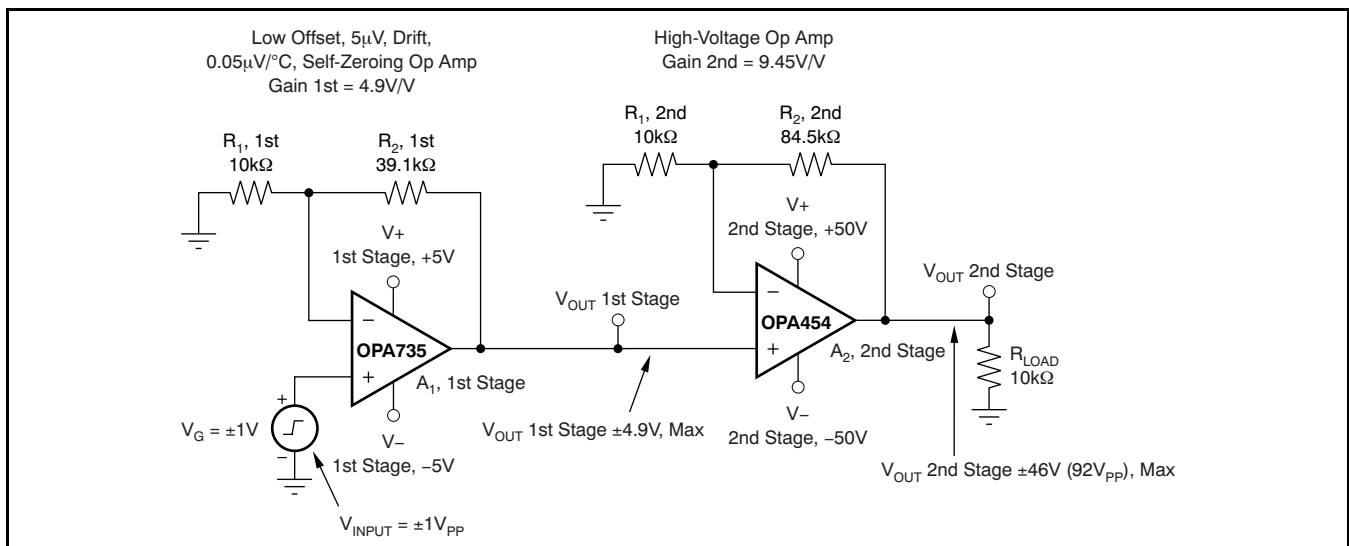

Figure 58. Two-Stage, High-Voltage Op Amp Circuit With Very Low Input Offset Temperature Drift

INCREASING OUTPUT CURRENT

The OPA454 drives an output current of a few milliamps to greater than 50mA while maintaining good op amp performance. See Figure 7 for open-loop gain versus temperature at various output current levels.

In applications where the 25mA output current is not sufficient to drive the required load, the output current can be increased by connecting two or more OPA454s in parallel, as Figure 59 shows. Amplifier A1 is the master amplifier and may be configured in virtually any op amp circuit. Amplifier A2, the slave, is configured as a unity-gain buffer. Alternatively, external output transistors can be used to boost output current. The circuit in Figure 60 is capable of supplying output currents up to 1A, with the transistors shown.

UNITY-GAIN NONINVERTING CONFIGURATION

When in the noninverting unity-gain configuration, the OPA454 has more gain peaking with increasing positive common-mode voltage and increasing temperature. It has less gain peaking with more negative common-mode voltage. As with all op amps, gain peaking increases with increasing capacitive load. A resistor and small capacitor placed in the feedback path can reduce gain peaking and increase stability.

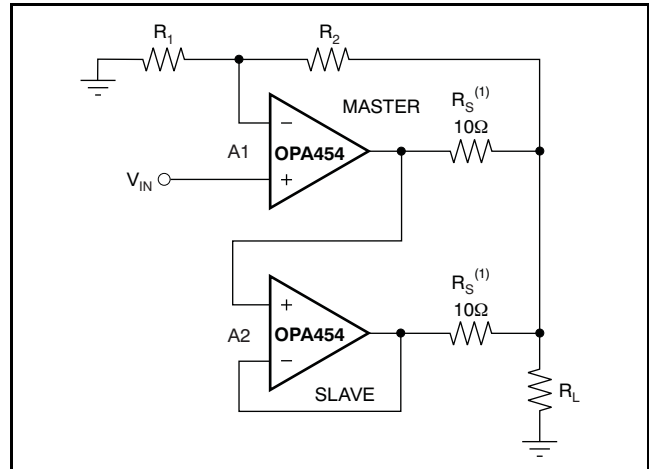

(1) R_S resistors minimize the circulating current that always flows between the two devices because of V_{OS} errors.

Figure 59. Parallel Amplifiers Increase Output Current Capability

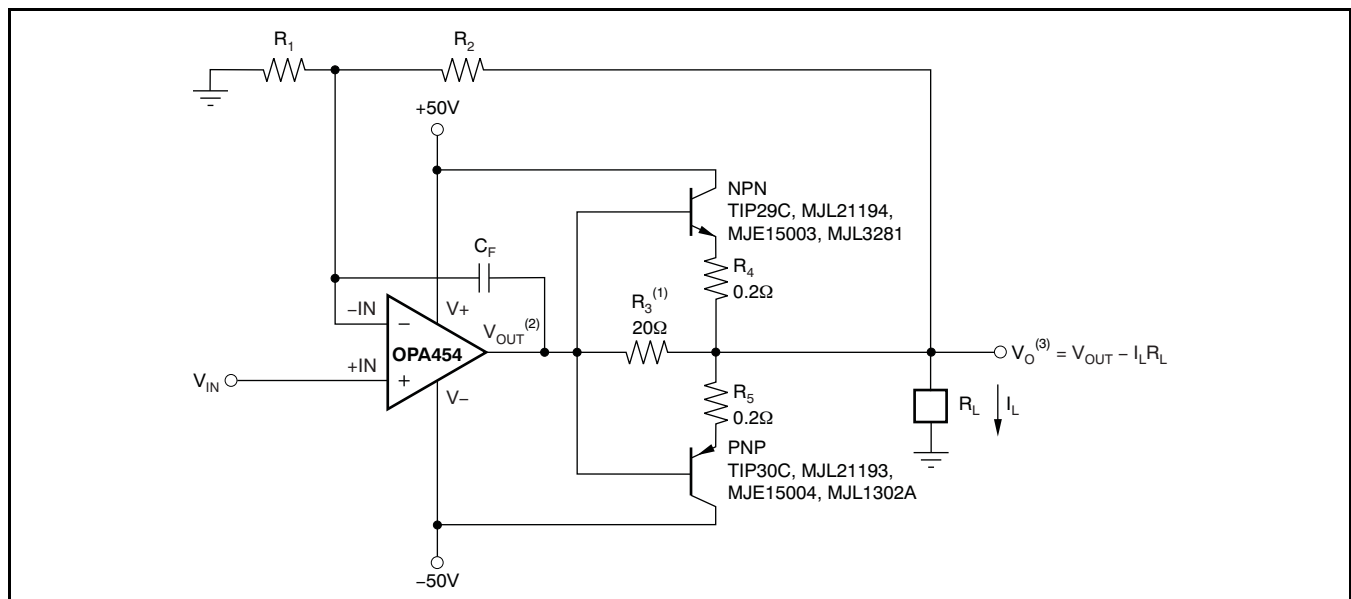

- (1) Provides current limit for OPA454 and allows the amplifier to drive the load when the output is between +0.7V and -0.7V.
- (2) Op amp V_{OUT} swings from +47V to -48V.
- (3) V_O swings from +44.1V to -45.1V at $I_L = 1A$.

Figure 60. External Output Transistors Boost Output Current Greater Than 1A

INPUT RANGE

The OPA454 is specified to give linear operation with input swing to within 2.5V of either supply. Generally, a gain of +1 is the most demanding configuration. Figure 61 and Figure 62 show output behavior as the input swings to within 0V of the rail, using the circuit shown in Figure 64. Figure 63 shows the behavior with an input signal that swings beyond the specified input range to within 1V of the rail, also using the circuit in Figure 64. Notice that the beginning of the phase reversal effect may be reduced by inserting series resistance (R_S) in the connection to the positive input. Note that V_{OUT} does not swing all the way to the opposite rail.

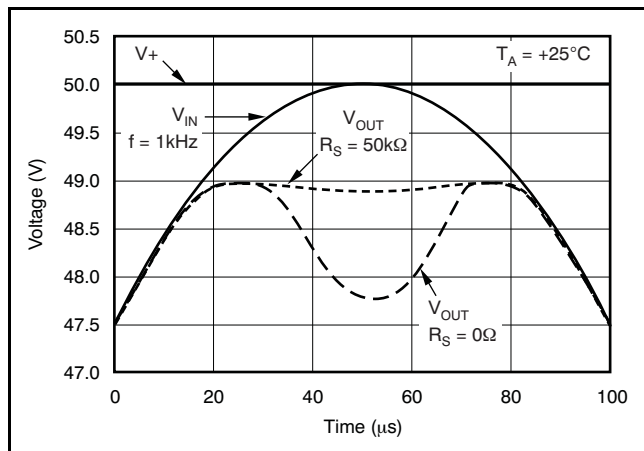

Figure 61. Output Voltage With Input Voltage Up To V_+

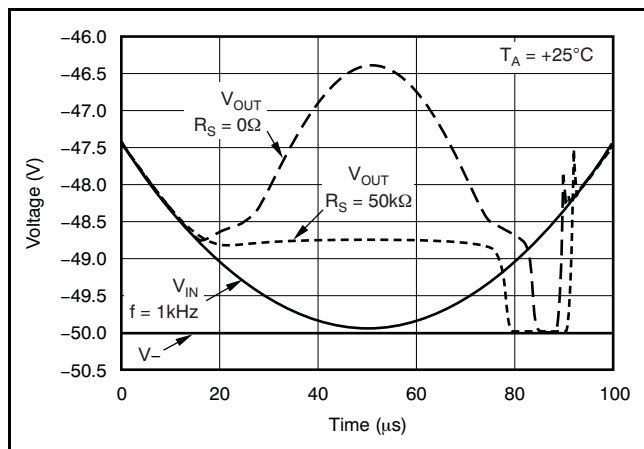

Figure 62. Output Voltage With Input Voltage Down To V_-

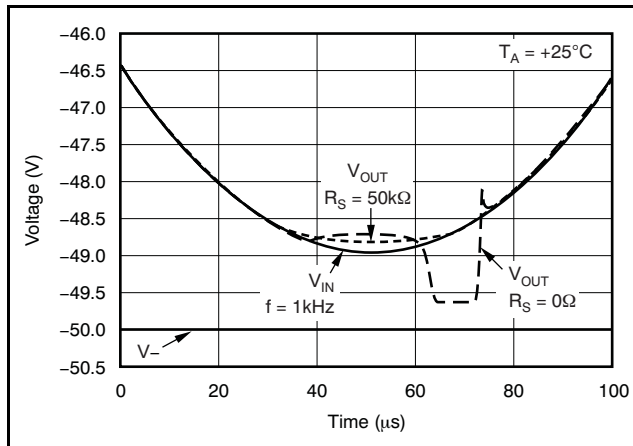

Figure 63. Output Voltage With Input Voltage Down To $(V_-) + 1V$

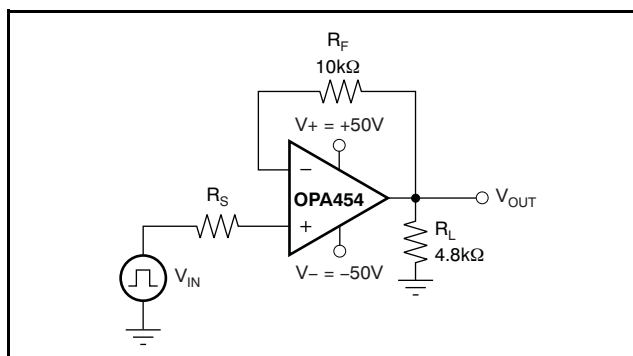

Figure 64. Input Range Test Circuit

OUTPUT RANGE

The OPA454 is specified to swing to within 1V of either supply rail with a 49kΩ load while maintaining excellent linearity. Swing to the rail decreases with increasing output current. The OPA454 can swing to within 2V of the negative rail and 3V of the positive rail with a 1.88kΩ load. The typical characteristic curve, *Output Voltage Swing vs Output Current* (Figure 11), shows this behavior in detail.

OPEN-LOOP GAIN LINEARITY

Figure 65 shows the nonlinear relationship of A_{OL} and output voltage. As Figure 65 shows, open-loop gain is lower with positive output voltage levels compared to negative voltage levels. Specifications in the Electrical Characteristics table are based upon the average gain measured at both output extremes.

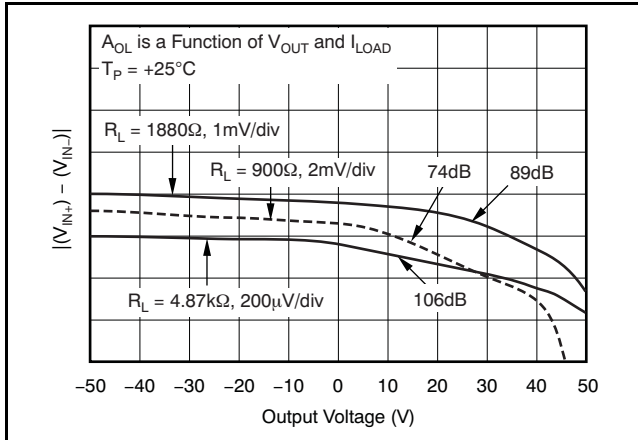

Figure 65. Differential Input Voltage (+IN to -IN) versus Output Voltage

SETTLING TIME

The circuit in Figure 66 is used to measure the settling time response. The left half of the circuit is a standard, false-summing junction test circuit used for settling time and open-loop gain measurement. R_1 and R_2 provide the gain and allow for measurement without connecting a scope probe directly to the summing junction, which can disturb proper op amp function by causing oscillation.

The right half of the circuit looks at the combination of both inverting and noninverting responses. R_5 and R_6 remove the large step response. The remaining voltage at V_2 shows the small-signal settling time that is centered on zero. This test circuit can be used for incoming inspection, real-time measurement, or in designing compensation circuits in system applications.

Table 2. Settling Time Measurement Circuit Configuration Using Different Gain Settings for Figure 66

COMPONENT	GAIN		
	1	5	10
R_1 (Ω)	10k	2k	1k
R_3 (Ω)	10k	2k	1k
R_7 (Ω)	10k	4k	9k
R_8 (Ω)	∞	1k	1k
V_{IN} (V _{PP})	20	16	8

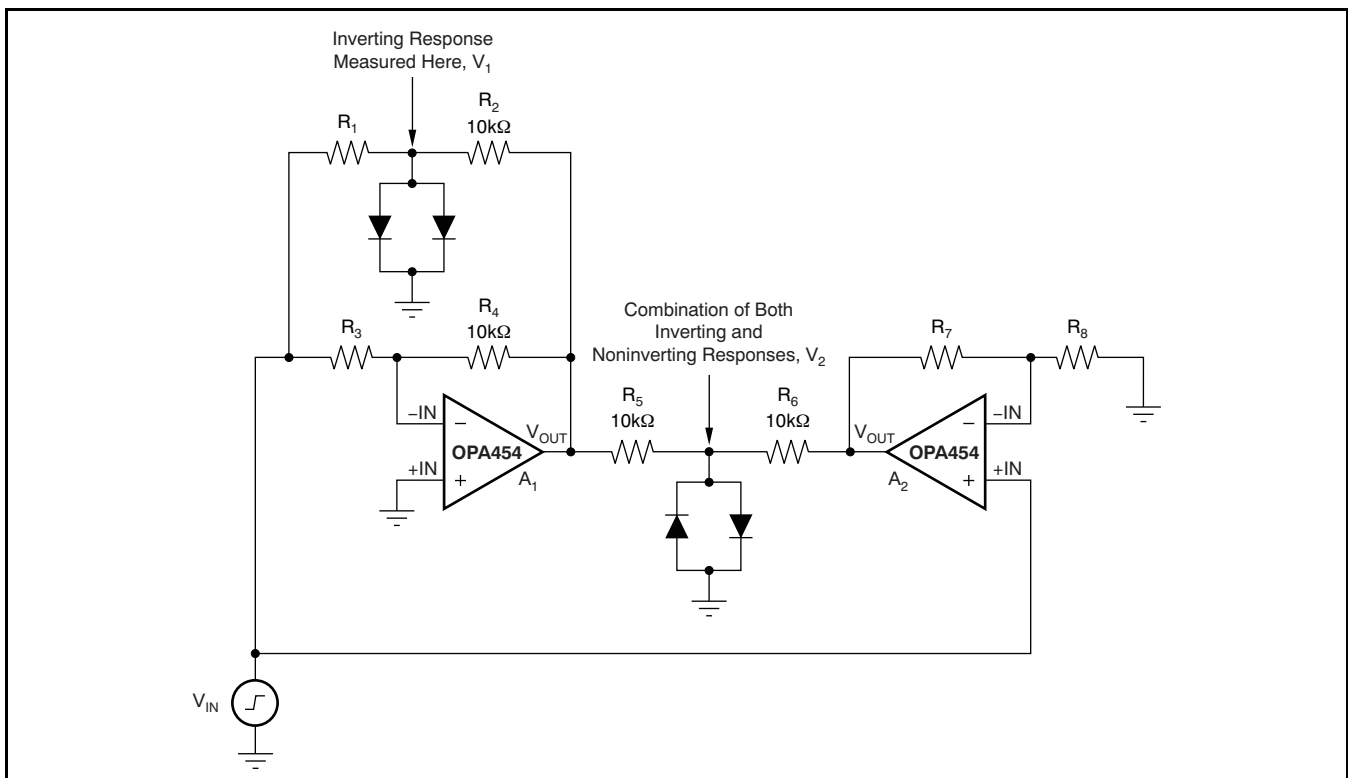

Figure 66. Settling Time Test Measurement Circuit

ENABLE AND E/D Com

If left disconnected, E/D Com is pulled near V^- (negative supply) by an internal $10\mu\text{A}$ current source. When left floating, ENABLE is held approximately 2V above E/D Com by an internal $1\mu\text{A}$ source. Even though active operation of the OPA454 results when the ENABLE and E/D Com pins are not connected, a moderately fast, negative-going signal capacitively coupled to the ENABLE pin can overpower the $1\mu\text{A}$ pull-up current and cause device shutdown. This behavior can appear as an oscillation and is encountered first near extreme cold temperatures. If the enable function is not used, a conservative approach is to connect ENABLE through a 30pF capacitor to a low impedance source. Another alternative is the connection of an external current source from V^+ (positive supply) sufficient to hold the enable level above the shutdown threshold. Figure 67 shows a circuit that connects ENABLE and E/D Com. Choosing R_P to be $1\text{M}\Omega$ with a +50V positive power supply voltage results in $I_P = 50\mu\text{A}$.

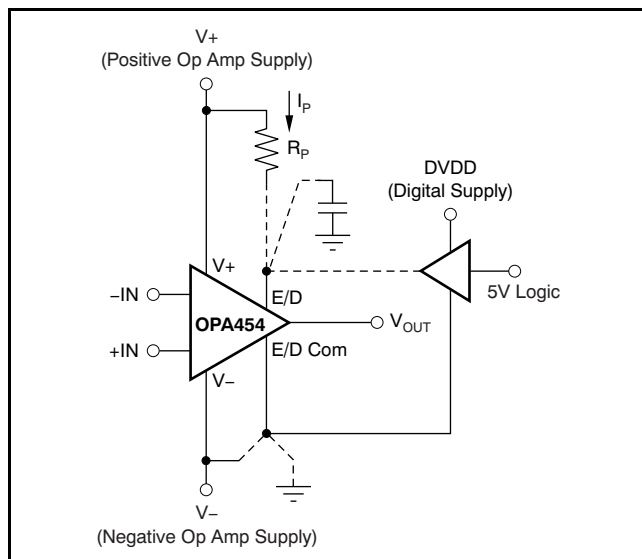

Figure 67. ENABLE and E/D Com

CURRENT LIMIT

Figure 24 and Figure 48 to Figure 50 show the current limit behavior of the OPA454. Current limiting is accomplished by internally limiting the drive to the output transistors. The output can supply the limited current continuously, unless the die temperature rises to $+150^\circ\text{C}$, which initiates thermal shutdown. With adequate heat-sinking, and use of the lowest possible supply voltage, the OPA454 can remain in current limit continuously without entering thermal shutdown. Although qualification studies have shown minimal parametric shifts induced by 1000 hours of thermal shutdown cycling, this mode of operation should be

avoided to maximize reliability. It is always best to provide proper heat-sinking (either by a physical plate or by airflow) to remain considerably below the thermal shutdown threshold. For longest operational life of the device, keep the junction temperature below $+125^\circ\text{C}$.

THERMAL PROTECTION

Figure 68 shows the thermal shutdown behavior of a socketed OPA454 that internally dissipates 1W. Unsoldered and in a socket, θ_{JA} of the DDA package is typically $+128^\circ\text{C}/\text{W}$. With the socket at $+25^\circ\text{C}$, the output stage temperature rises to the shutdown temperature of $+150^\circ\text{C}$, which triggers automatic thermal shutdown of the device. The device remains in thermal shutdown (output is in a high-impedance state) until it cools to $+130^\circ\text{C}$ where it again is powered. This thermal protection hysteresis feature typically prevents the amplifier from leaving the safe operating area, even with a direct short from the output to ground or either supply. The rail-to-rail supply voltage at which catastrophic breakdown occurs is typically 135V at $+25^\circ\text{C}$. However, the absolute maximum specification is 120V, and the OPA454 should not be allowed to exceed 120V under any condition. Failure as a result of breakdown, caused by spiking currents into inductive loads (particularly with elevated supply voltage), is not prevented by the thermal protection architecture.

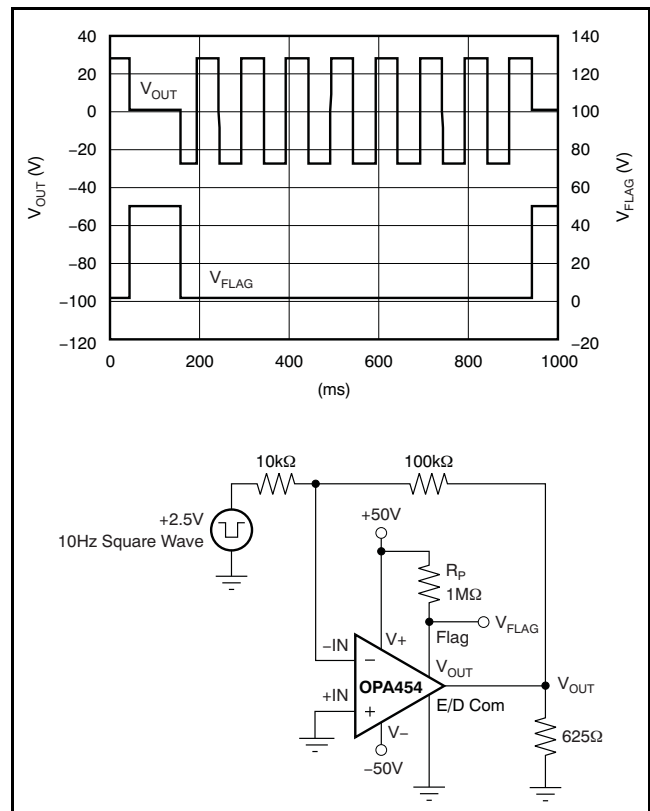

Figure 68. Thermal Shutdown

POWER DISSIPATION

Power dissipation depends on power supply, signal, and load conditions. For dc signals, power dissipation is equal to the product of the output current times the voltage across the conducting output transistor, $P_D = I_L (V_S - V_O)$. Power dissipation can be minimized by using the lowest possible power-supply voltage necessary to assure the required output voltage swing.

For resistive loads, the maximum power dissipation occurs at a dc output voltage of one-half the power-supply voltage. Dissipation with ac signals is lower because the root-mean square (RMS) value determines heating. Application Bulletin [SBOA022](#) explains how to calculate or measure dissipation with unusual loads or signals. For constant current source circuits, maximum power dissipation occurs at the minimum output voltage, as [Figure 69](#) shows.

The OPA454 can supply output currents of 25mA and larger. Supplying this amount of current presents no problem for some op amps operating from $\pm 15V$ supplies. However, with high supply voltages, internal power dissipation of the op amp can be quite high. Operation from a single power supply (or unbalanced power supplies) can produce even greater power dissipation because a large voltage is impressed across the conducting output transistor. Applications with high power dissipation may require a heatsink, or heat spreader.

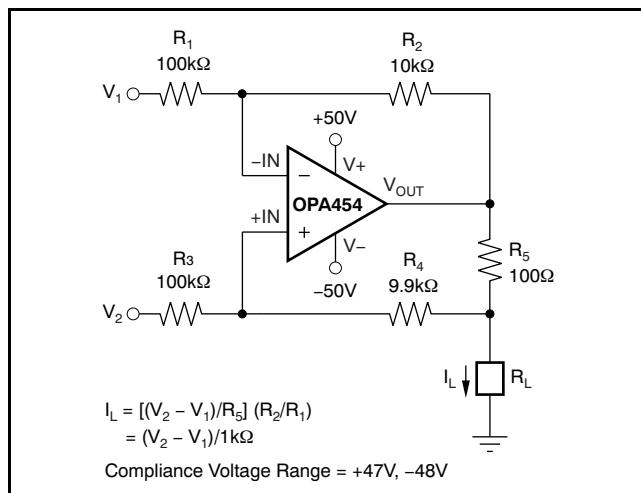

NOTE: $R_1 = R_3$ and $R_2 = R_4 + R_5$.

Figure 69. Precision Voltage-to-Current Converter with Differential Inputs

HEATSINKING

Power dissipated in the OPA454 causes the junction temperature to rise. For reliable operation, junction temperature should be limited to +125°C, maximum. Maintaining a lower junction temperature always results in higher reliability. Some applications require a heatsink to assure that the maximum operating junction temperature is not exceeded. Junction temperature can be determined according to [Equation 1](#):

$$T_J = T_A + P_D \theta_{JA} \quad (1)$$

Package thermal resistance, θ_{JA} , is affected by mounting techniques and environments. Poor air circulation and use of sockets can significantly increase thermal resistance to the ambient environment. Many op amps placed closely together also increase the surrounding temperature. Best thermal performance is achieved by soldering the op amp onto a circuit board with wide printed circuit traces to allow greater conduction through the op amp leads. Increasing circuit board copper area to approximately 0.5in² decreases thermal resistance; however, minimal improvement occurs beyond 0.5in², as shown in [Figure 70](#).

For additional information on determining heatsink requirements, consult Application Bulletin [SBOA021](#) (available for download at www.ti.com).

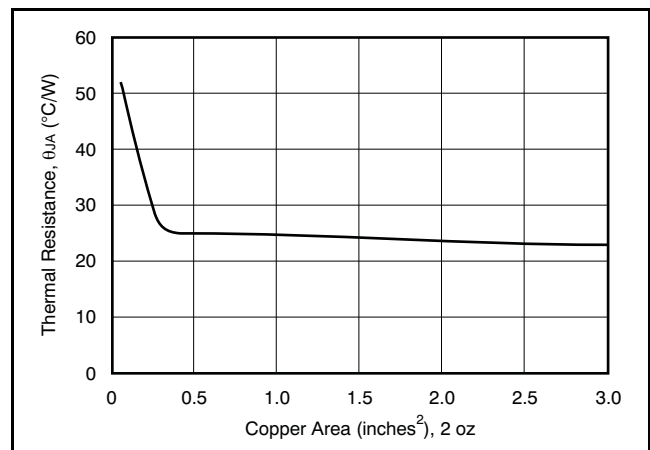

Figure 70. Thermal Resistance versus Circuit Board Copper Area

THERMALLY-ENHANCED PowerPAD PACKAGE

The OPA454 comes in an SO-8 PowerPAD version that provides an extremely low thermal resistance (θ_{JC}) path between the die and the exterior of the package. This package features an exposed thermal pad. This thermal pad has direct thermal contact with the die; thus, excellent thermal performance is achieved by providing a good thermal path away from the thermal pad.

The OPA454 SO-8 PowerPAD is a standard-size SO-8 package constructed using a downset leadframe upon which the die is mounted, as [Figure 71](#) shows. This arrangement results in the lead frame being exposed as a thermal pad on the underside of the package. The thermal pad on the bottom of the IC can then be soldered directly to the PCB, using the PCB as a heatsink. In addition,

plated-through holes (vias) provide a low thermal resistance heat flow path to the back side of the PCB. This architecture enhances the OPA454 power dissipation capability significantly, eliminates the use of bulky heatsinks and slugs traditionally used in thermal packages, and allows the OPA454 to be easily mounted using standard PCB assembly techniques. NOTE: Because the SO-8 PowerPAD is pin-compatible with standard SO-8 packages, the OPA454 is a drop-in replacement for operational amplifiers in existing sockets. Soldering the PowerPAD to the PCB is always required, even with applications that have low power dissipation. Soldering the device to the PCB provides the necessary thermal and mechanical connection between the leadframe die pad and the PCB.

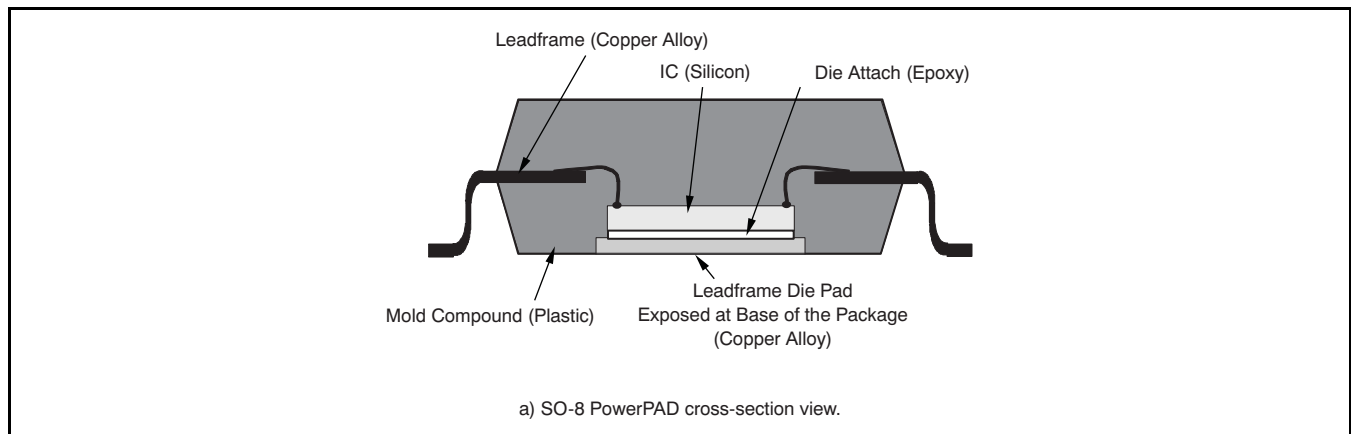

Figure 71. Cross-Section View of a PowerPAD Package

PowerPAD LAYOUT GUIDELINES

The PowerPAD package allows for both assembly and thermal management in one manufacturing operation. During the surface-mount solder operation (when the leads are being soldered), the thermal pad must be soldered to a copper area underneath the package. Through the use of thermal paths within this copper area, heat can be conducted away from the package into either a ground plane or other heat-dissipating device. Soldering the PowerPAD to the PCB is always required, even with applications that have low power dissipation. Follow these steps to attach the device to the PCB:

1. The PowerPAD must be connected to the most negative supply voltage on the device, V₋.
2. Prepare the PCB with a top-side etch pattern. There should be etching for the leads as well as etch for the thermal pad.
3. Use of thermal vias improves heat dissipation, but are not required. The thermal pad can connect to the PCB using an area equal to the pad size with no vias, but externally connected to V₋.
4. Place recommended holes in the area of the thermal pad. Recommended thermal land size and thermal via patterns for the SO-8 DDA package are shown in the thermal land pattern mechanical drawing appended at the end of this document. These holes should be 13 mils (.013in, or 0.3302mm) in diameter. Keep them small, so that solder wicking through the holes is not a problem during reflow. The minimum recommended number of holes for the SO-8 PowerPAD package is five.
5. Additional vias may be placed anywhere along the thermal plane outside of the thermal pad area. These vias help dissipate the heat generated by the OPA454 IC. These additional vias may be larger than the 13 mil diameter vias directly under the thermal pad. They can be larger because they are not in the thermal pad area to be soldered; thus, wicking is not a problem.
6. Connect all holes to the internal power plane of the correct voltage potential (V₋).
7. When connecting these holes to the plane, do not use the typical web or spoke via connection methodology. Web connections have a high thermal resistance connection that is useful for slowing the heat transfer during soldering operations, making the soldering of vias that have plane connections easier. In this application, however, low thermal resistance is desired for the most efficient heat transfer. Therefore, the holes under the OPA454 PowerPAD package should make the connections to the internal plane with a complete connection around the entire circumference of the plated-through hole.
8. The top-side solder mask should leave the terminals of the package and the thermal pad area exposed. The bottom-side solder mask should cover the holes of the thermal pad area. This masking prevents solder from being pulled away from the thermal pad area during the reflow process.
9. Apply solder paste to the exposed thermal pad area and all of the IC terminals.
10. With these preparatory steps in place, the PowerPAD IC is simply placed in position and run through the solder reflow operation as any standard surface-mount component. This preparation results in a properly installed part.

For detailed information on the PowerPAD package, including thermal modeling considerations and repair procedures, see technical brief [SLMA002 PowerPAD Thermally-Enhanced Package](#), available for download at www.ti.com.

TYPICAL APPLICATIONS

Figure 72 and Figure 73 illustrate the OPA454 in a programmable voltage source and a bridge circuit, respectively.

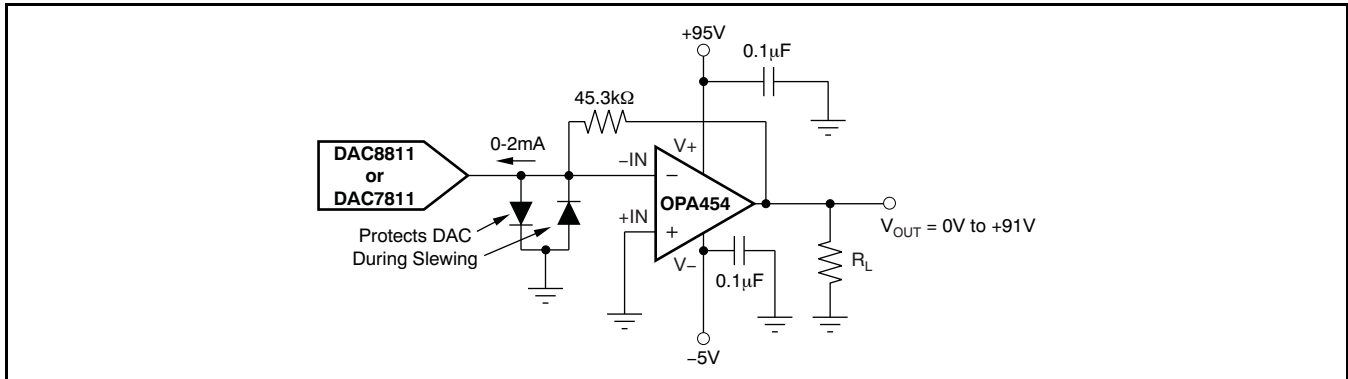
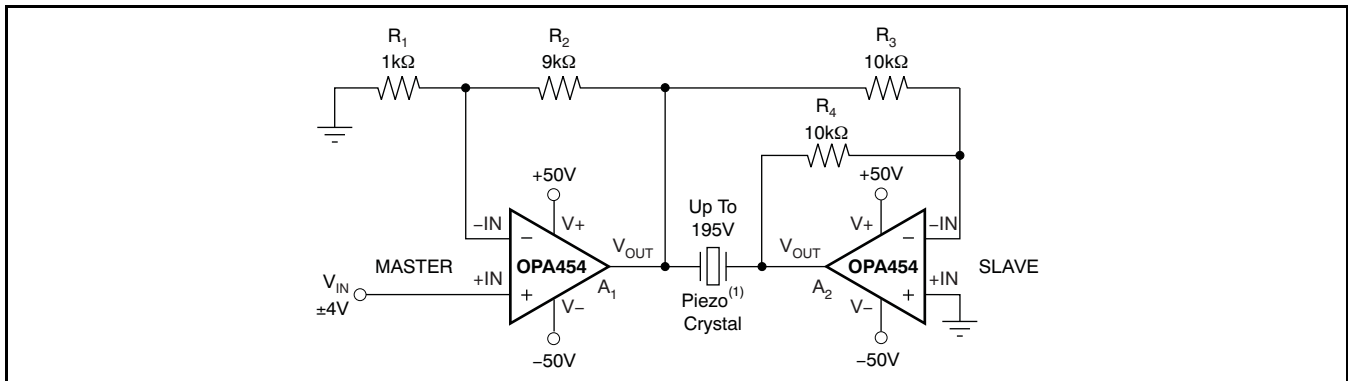

Figure 72. Programmable Voltage Source



(1) For transducers with large capacitance, stabilization may become an issue. Be certain that the *Master* amplifier is stable before stabilizing the *Slave* amplifier.

Figure 73. Bridge Circuit Doubles Voltage for Exciting Piezo Crystals

Figure 74 uses three OPA454s to create a high-voltage instrumentation amplifier. $V_{CM} \pm V_{SIG}$ must be between $(V-) + 2.5V$ and $(V+) - 2.5V$. The maximum supply voltage equals $\pm 50V$ or $100V$ total.

Figure 75 uses three OPA454s to measure current in a high-side shunt application. V_{SUPPLY} must be greater than V_{CM} . V_{CM} must be between $(V-) + 2.5V$ and $(V+) - 2.5V$. Adhering to these restrictions keeps V_1 and V_2 within the voltage range required for linear operation of the OPA454. For example, if $V+ = 50V$ and $V- = 50V$, then $V_1 = +47.5V$ (maximum) and $V_2 = -47.5V$ (minimum). The maximum supply voltage equals $\pm 50V$, or $100V$ total.

See Figure 76 and Figure 79 for example circuits that use the OPA454 in an output voltage boost configurations in three and six op amp output stages, respectively.

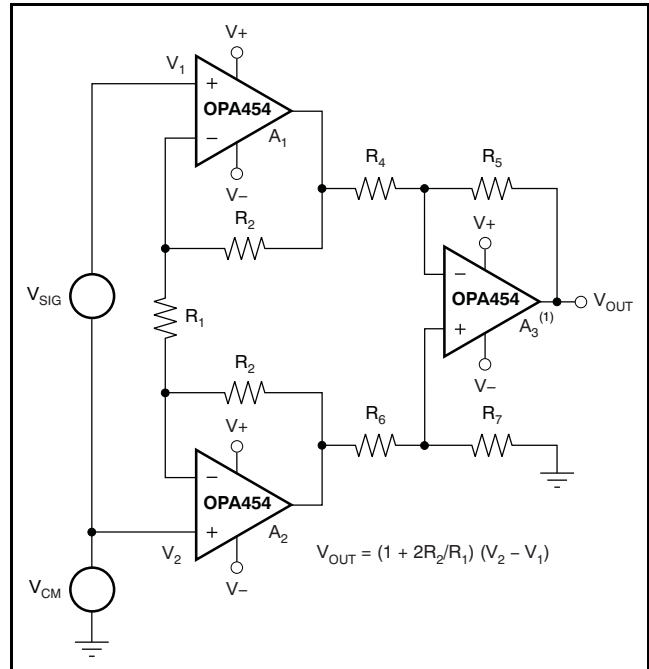

(1) The linear input range is limited by the output swing on the input amplifiers, A_1 and A_2 .

Figure 74. High-Voltage Instrumentation Amplifier

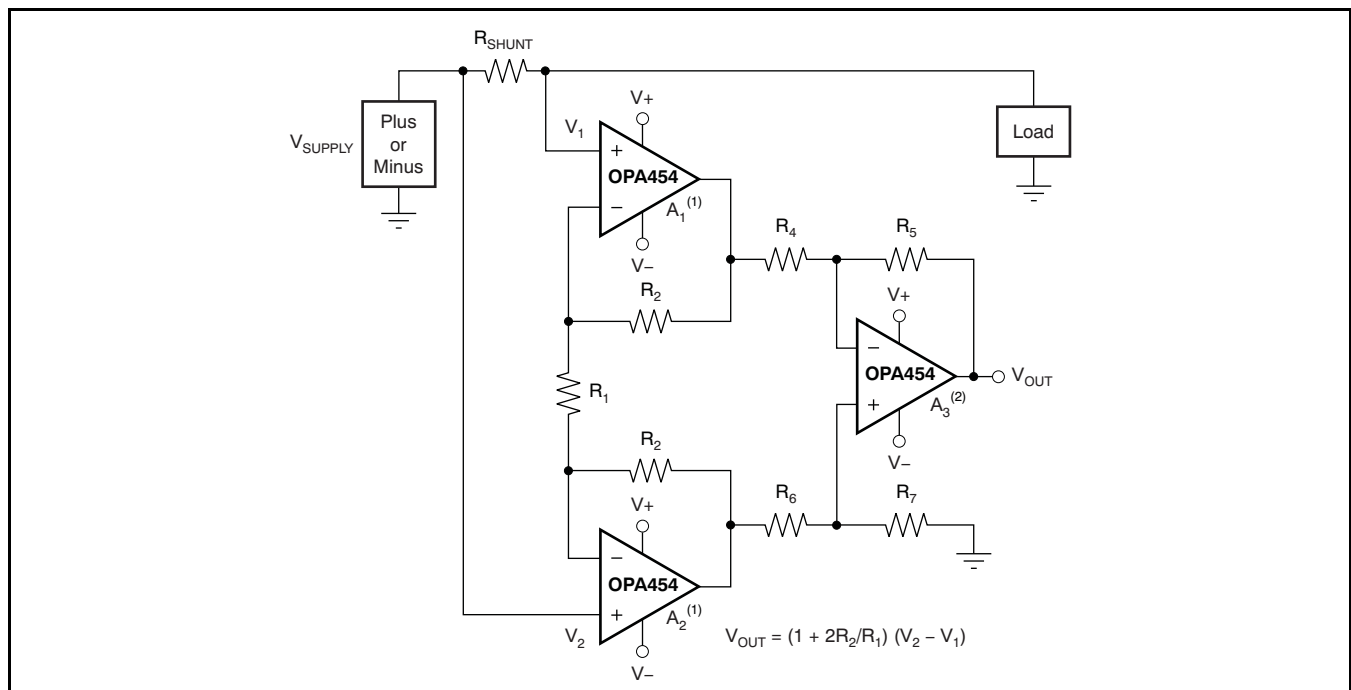

(1) To increase the linear input voltage range, configure A_1 and A_2 as unity-gain followers.

(2) The linear input range is limited by the output swing on the input amplifiers, A_1 and A_2 .

Figure 75. High-Voltage Instrumentation Amplifier for Measuring High-Side Shunt

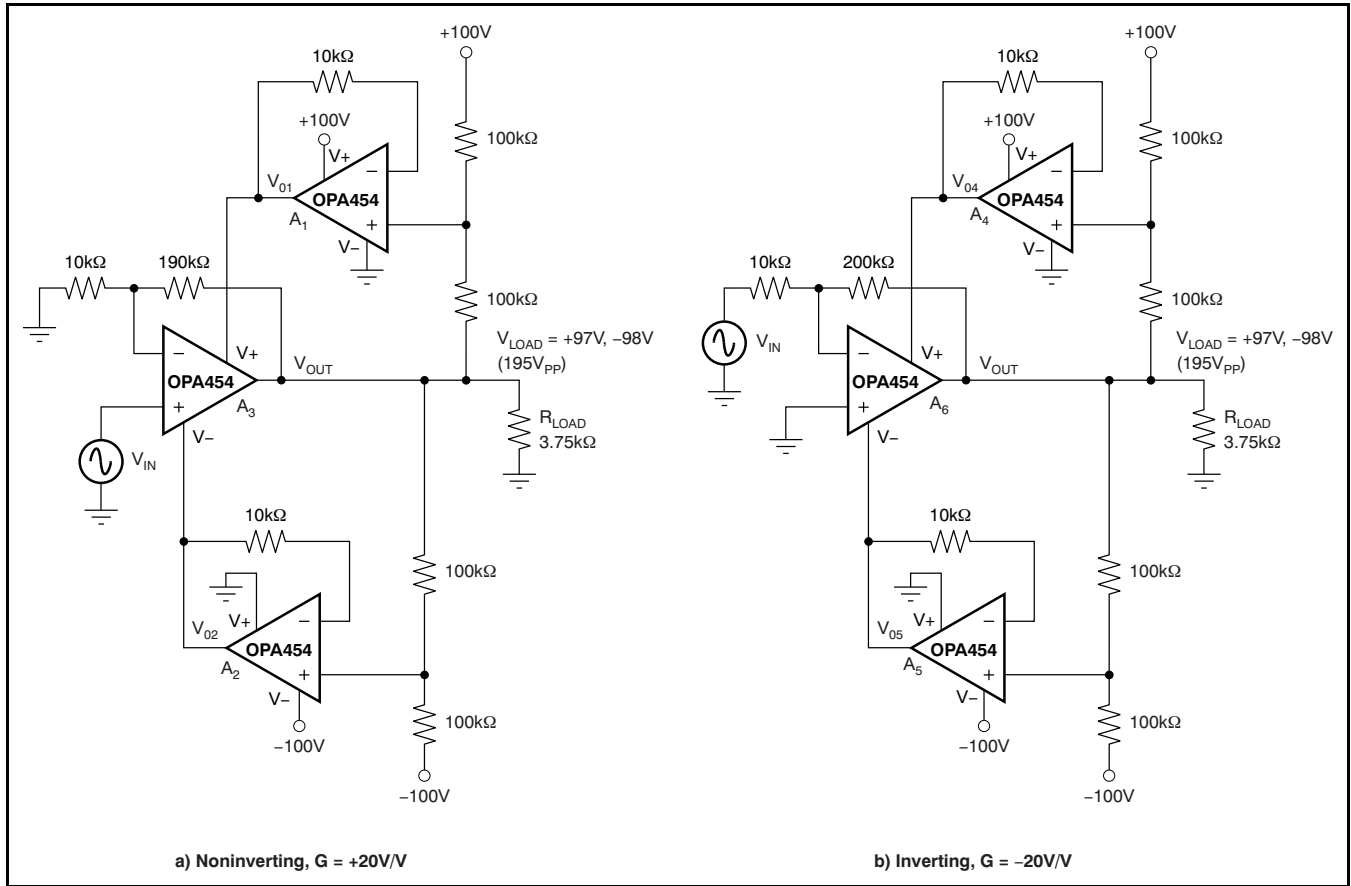

Figure 76. Output Voltage Boost With +97V, -98V (195V_{PP}) Across Load Connected to Ground (3 Op Amp Output Stage, see Figure 77 and Figure 78)

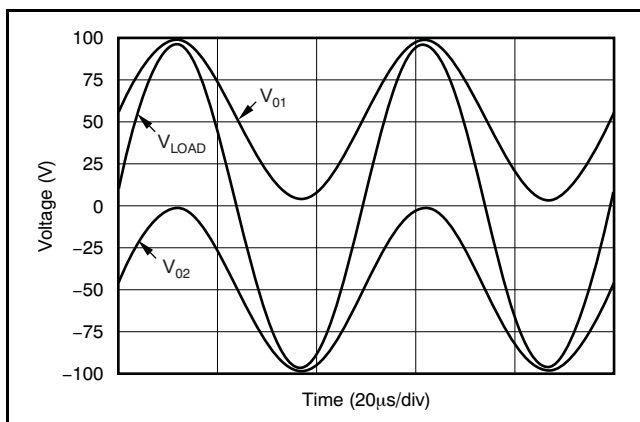

Figure 77. 195V_{PP} On 3.75kΩ Load to Ground 20kHz, Uses 3 OPA454s, 100V Supplies

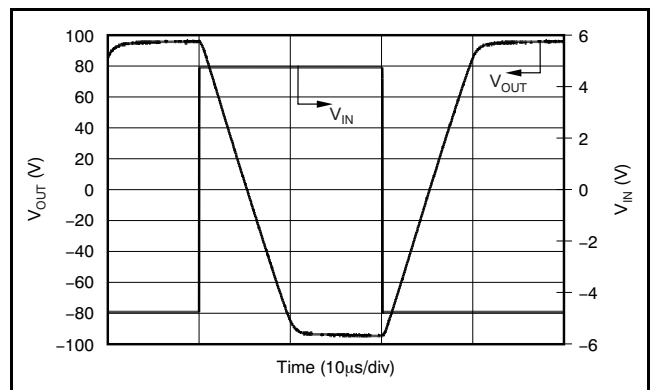

Figure 78. 3.75kΩ Load to Ground G = +20, 3 OPA454s, 100V Supplies (Note SR of 18V/μs, which is slightly higher than the specified 13V/μs due to tracking of the power-supply voltage)

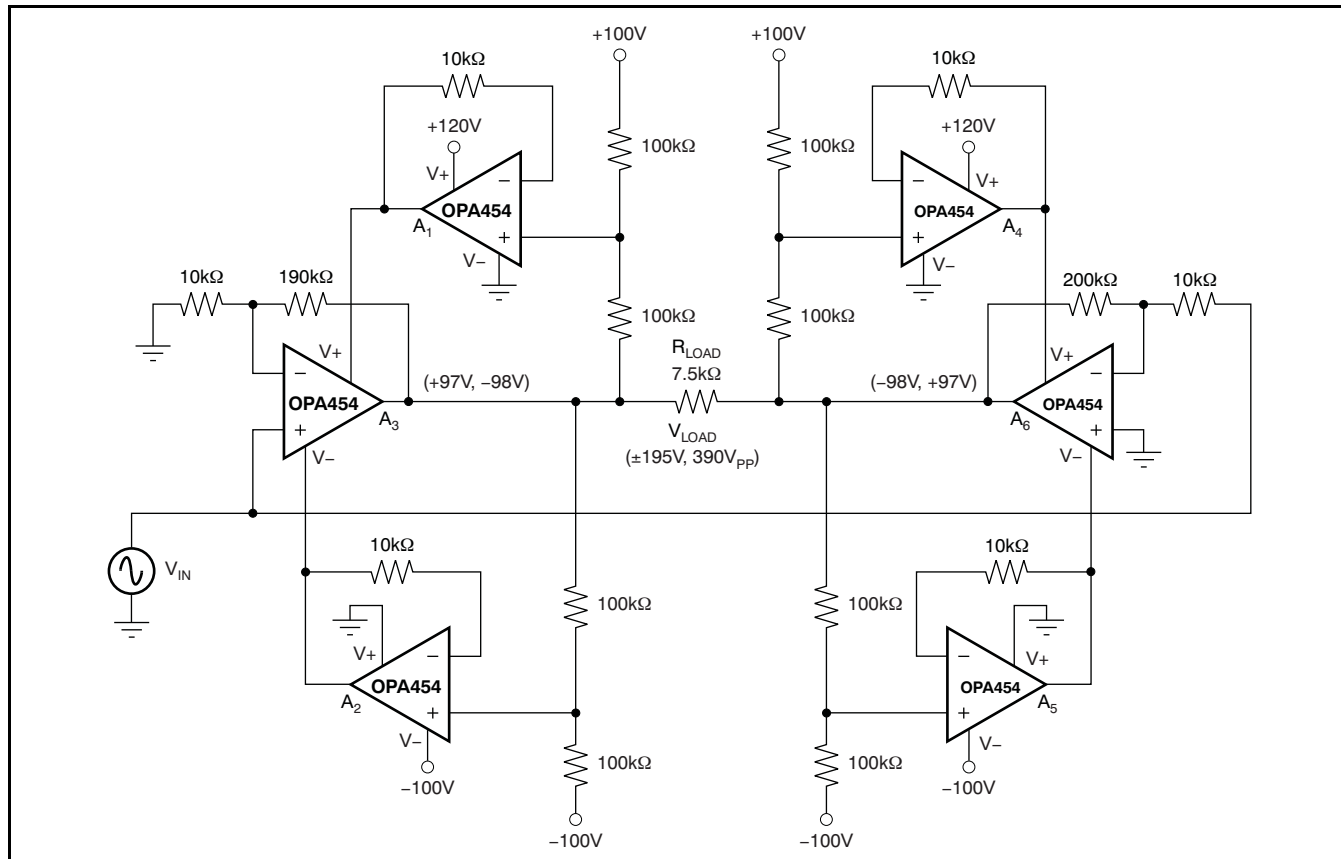

Figure 79. Output Voltage Boost With $\pm 195V$ ($390V_{PP}$) Across Bridge-Tied Load (6 Op Amps, see Figure 80 and Figure 81)

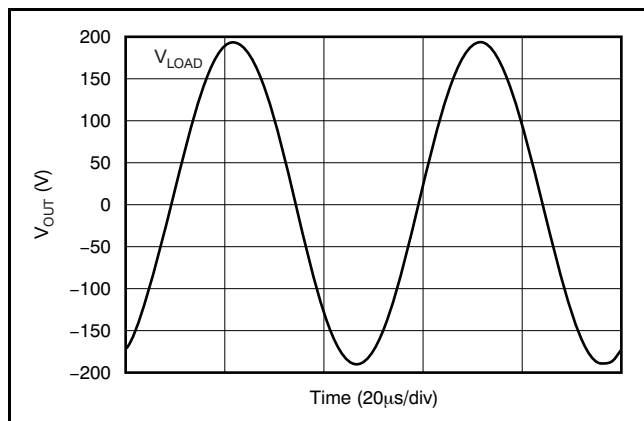

Figure 80. $390V_{PP}$ Across $7.5k\Omega$ Load $20kHz$, Uses 6 OPA454s, $100V$ Supplies

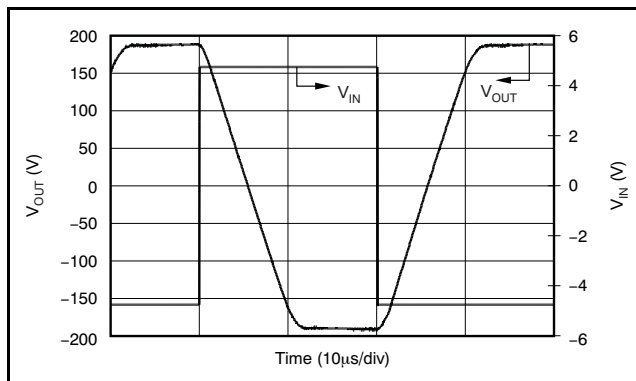

Figure 81. $7.5k\Omega$ Load $G = +20$, 6 OPA454s, $100V$ Supplies (Note SR of $34V/\mu s$, which is significantly higher than the specified $13V/\mu s$ due to tracking of the power-supply voltage)

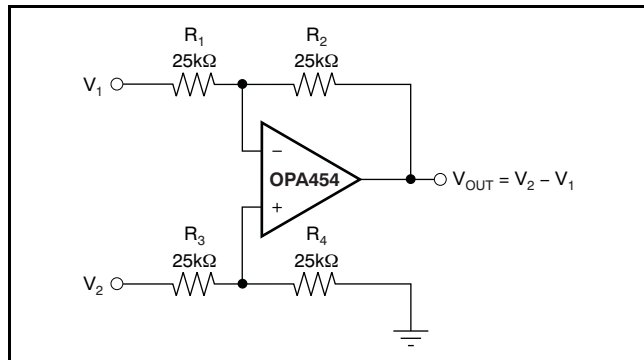

Figure 82. High-Voltage Difference Amplifier

HIGH-COMPLIANCE VOLTAGE CURRENT SOURCES

This section describes four different applications utilizing high compliance voltage current sources with differential inputs. Figure 69 and Figure 83 illustrate the different applications.

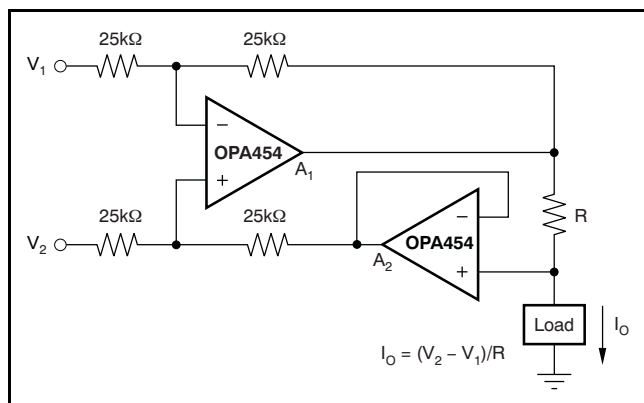

Figure 83. Differential Input Voltage-to-Current Converter for Low I_{OUT}

A red light emitting diode (LED) was used to generate Figure 84.

Gain of the avalanche photodiode (APD) is adjusted by changing the voltage across the APD. Gain starts to increase when reverse voltage is increased beyond 130V for this APD diode. Figure 85 shows this structure.

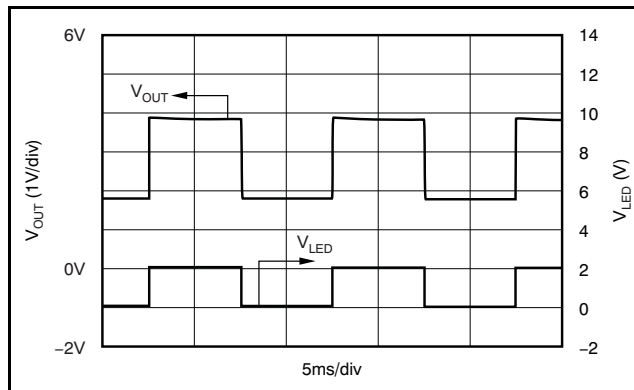

Figure 84. Avalanche Photodiode Circuit

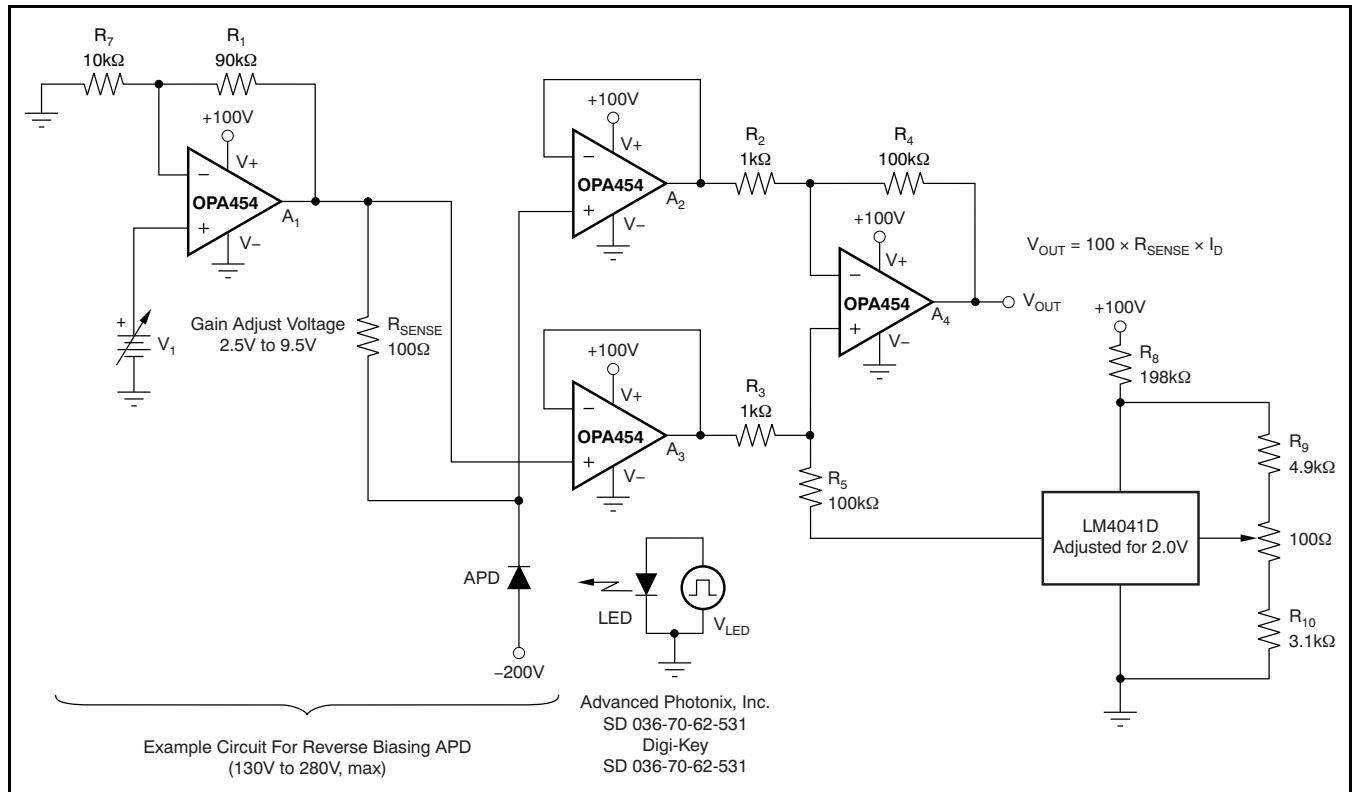

Figure 85. APD Gain Adjustment Using the OPA454, High-Voltage Op Amp

PACKAGING INFORMATION

Orderable Device	Status ⁽¹⁾	Package Type	Package Drawing	Pins	Package Qty	Eco Plan ⁽²⁾	Lead/Ball Finish	MSL Peak Temp ⁽³⁾
OPA454AIDDA	ACTIVE	SO Power PAD	DDA	8	75	Green (RoHS & no Sb/Br)	CU NIPDAU	Level-2-260C-1 YEAR
OPA454AIDDAG4	ACTIVE	SO Power PAD	DDA	8	75	Green (RoHS & no Sb/Br)	CU NIPDAU	Level-2-260C-1 YEAR
OPA454AIDDAR	ACTIVE	SO Power PAD	DDA	8	2500	Green (RoHS & no Sb/Br)	CU NIPDAU	Level-2-260C-1 YEAR
OPA454AIDDARG4	ACTIVE	SO Power PAD	DDA	8	2500	Green (RoHS & no Sb/Br)	CU NIPDAU	Level-2-260C-1 YEAR

⁽¹⁾ The marketing status values are defined as follows:

ACTIVE: Product device recommended for new designs.

LIFEBUY: TI has announced that the device will be discontinued, and a lifetime-buy period is in effect.

NRND: Not recommended for new designs. Device is in production to support existing customers, but TI does not recommend using this part in a new design.

PREVIEW: Device has been announced but is not in production. Samples may or may not be available.

OBSOLETE: TI has discontinued the production of the device.

⁽²⁾ Eco Plan - The planned eco-friendly classification: Pb-Free (RoHS), Pb-Free (RoHS Exempt), or Green (RoHS & no Sb/Br) - please check <http://www.ti.com/productcontent> for the latest availability information and additional product content details.

TBD: The Pb-Free/Green conversion plan has not been defined.

Pb-Free (RoHS): TI's terms "Lead-Free" or "Pb-Free" mean semiconductor products that are compatible with the current RoHS requirements for all 6 substances, including the requirement that lead not exceed 0.1% by weight in homogeneous materials. Where designed to be soldered at high temperatures, TI Pb-Free products are suitable for use in specified lead-free processes.

Pb-Free (RoHS Exempt): This component has a RoHS exemption for either 1) lead-based flip-chip solder bumps used between the die and package, or 2) lead-based die adhesive used between the die and leadframe. The component is otherwise considered Pb-Free (RoHS compatible) as defined above.

Green (RoHS & no Sb/Br): TI defines "Green" to mean Pb-Free (RoHS compatible), and free of Bromine (Br) and Antimony (Sb) based flame retardants (Br or Sb do not exceed 0.1% by weight in homogeneous material)

⁽³⁾ MSL, Peak Temp. -- The Moisture Sensitivity Level rating according to the JEDEC industry standard classifications, and peak solder temperature.

Important Information and Disclaimer:The information provided on this page represents TI's knowledge and belief as of the date that it is provided. TI bases its knowledge and belief on information provided by third parties, and makes no representation or warranty as to the accuracy of such information. Efforts are underway to better integrate information from third parties. TI has taken and continues to take reasonable steps to provide representative and accurate information but may not have conducted destructive testing or chemical analysis on incoming materials and chemicals. TI and TI suppliers consider certain information to be proprietary, and thus CAS numbers and other limited information may not be available for release.

In no event shall TI's liability arising out of such information exceed the total purchase price of the TI part(s) at issue in this document sold by TI to Customer on an annual basis.

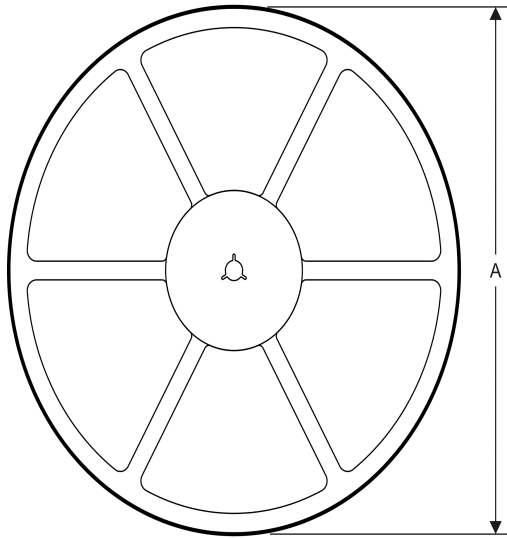
TAPE AND REEL INFORMATION
REEL DIMENSIONS

TAPE DIMENSIONS

A0	Dimension designed to accommodate the component width
B0	Dimension designed to accommodate the component length
K0	Dimension designed to accommodate the component thickness
W	Overall width of the carrier tape
P1	Pitch between successive cavity centers

TAPE AND REEL INFORMATION

*All dimensions are nominal

Device	Package Type	Package Drawing	Pins	SPQ	Reel Diameter (mm)	Reel Width W1 (mm)	A0 (mm)	B0 (mm)	K0 (mm)	P1 (mm)	W (mm)	Pin1 Quadrant
OPA454AIDDAR	SO Power PAD	DDA	8	2500	330.0	12.4	6.4	5.2	2.1	8.0	12.0	Q1

TAPE AND REEL BOX DIMENSIONS



*All dimensions are nominal

Device	Package Type	Package Drawing	Pins	SPQ	Length (mm)	Width (mm)	Height (mm)
OPA454AIDDAR	SO PowerPAD	DDA	8	2500	367.0	367.0	35.0

DDA (R-PDSO-G8)

PowerPAD™ PLASTIC SMALL-OUTLINE

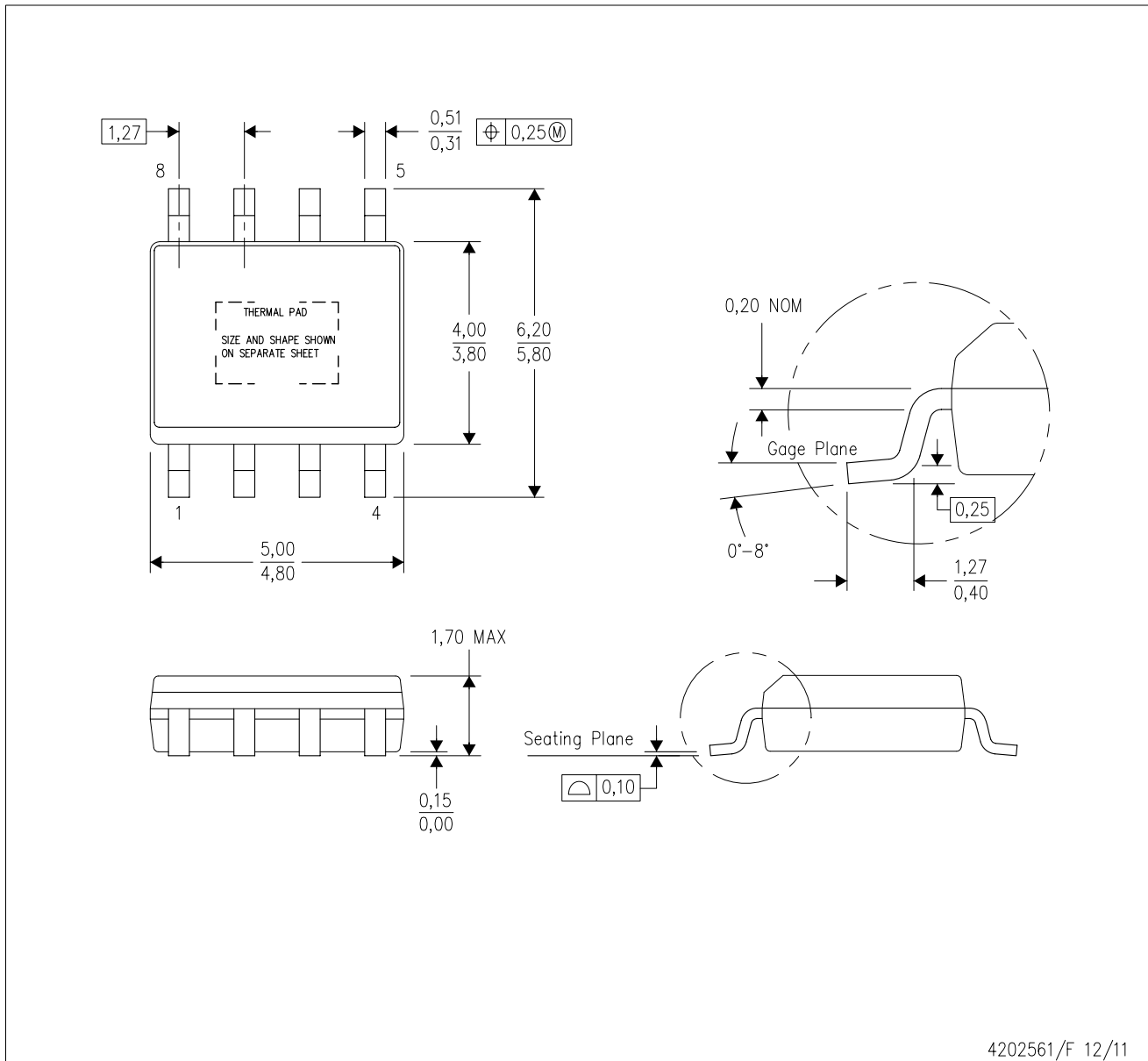

- NOTES:
- A. All linear dimensions are in millimeters. Dimensioning and tolerancing per ASME Y14.5-1994.
 - B. This drawing is subject to change without notice.
 - C. Body dimensions do not include mold flash or protrusion not to exceed 0,15.
 - D. This package is designed to be soldered to a thermal pad on the board. Refer to Technical Brief, PowerPad Thermally Enhanced Package, Texas Instruments Literature No. SLMA002 for information regarding recommended board layout. This document is available at www.ti.com <<http://www.ti.com>>.
 - E. See the additional figure in the Product Data Sheet for details regarding the exposed thermal pad features and dimensions.
 - F. This package complies to JEDEC MS-012 variation BA

PowerPAD is a trademark of Texas Instruments.

DDA (R-PDSO-G8)

PowerPAD™ PLASTIC SMALL OUTLINE

THERMAL INFORMATION

This PowerPAD™ package incorporates an exposed thermal pad that is designed to be attached to a printed circuit board (PCB). The thermal pad must be soldered directly to the PCB. After soldering, the PCB can be used as a heatsink. In addition, through the use of thermal vias, the thermal pad can be attached directly to the appropriate copper plane shown in the electrical schematic for the device, or alternatively, can be attached to a special heatsink structure designed into the PCB. This design optimizes the heat transfer from the integrated circuit (IC).

For additional information on the PowerPAD package and how to take advantage of its heat dissipating abilities, refer to Technical Brief, PowerPAD Thermally Enhanced Package, Texas Instruments Literature No. SLMA002 and Application Brief, PowerPAD Made Easy, Texas Instruments Literature No. SLMA004. Both documents are available at www.ti.com.

The exposed thermal pad dimensions for this package are shown in the following illustration.

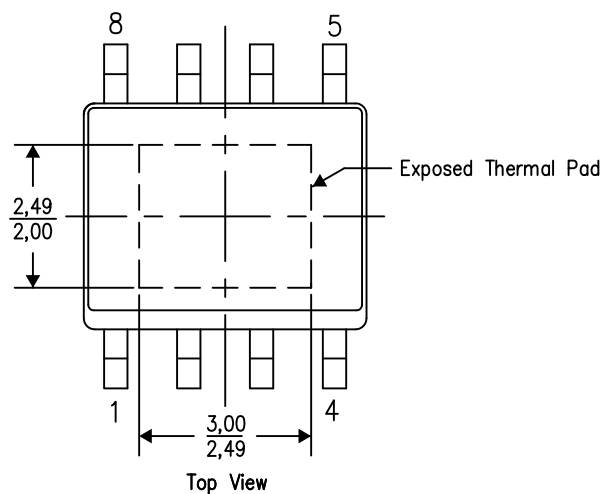

Exposed Thermal Pad Dimensions

4206322-3/L 05/12

NOTE: A. All linear dimensions are in millimeters

PowerPAD is a trademark of Texas Instruments

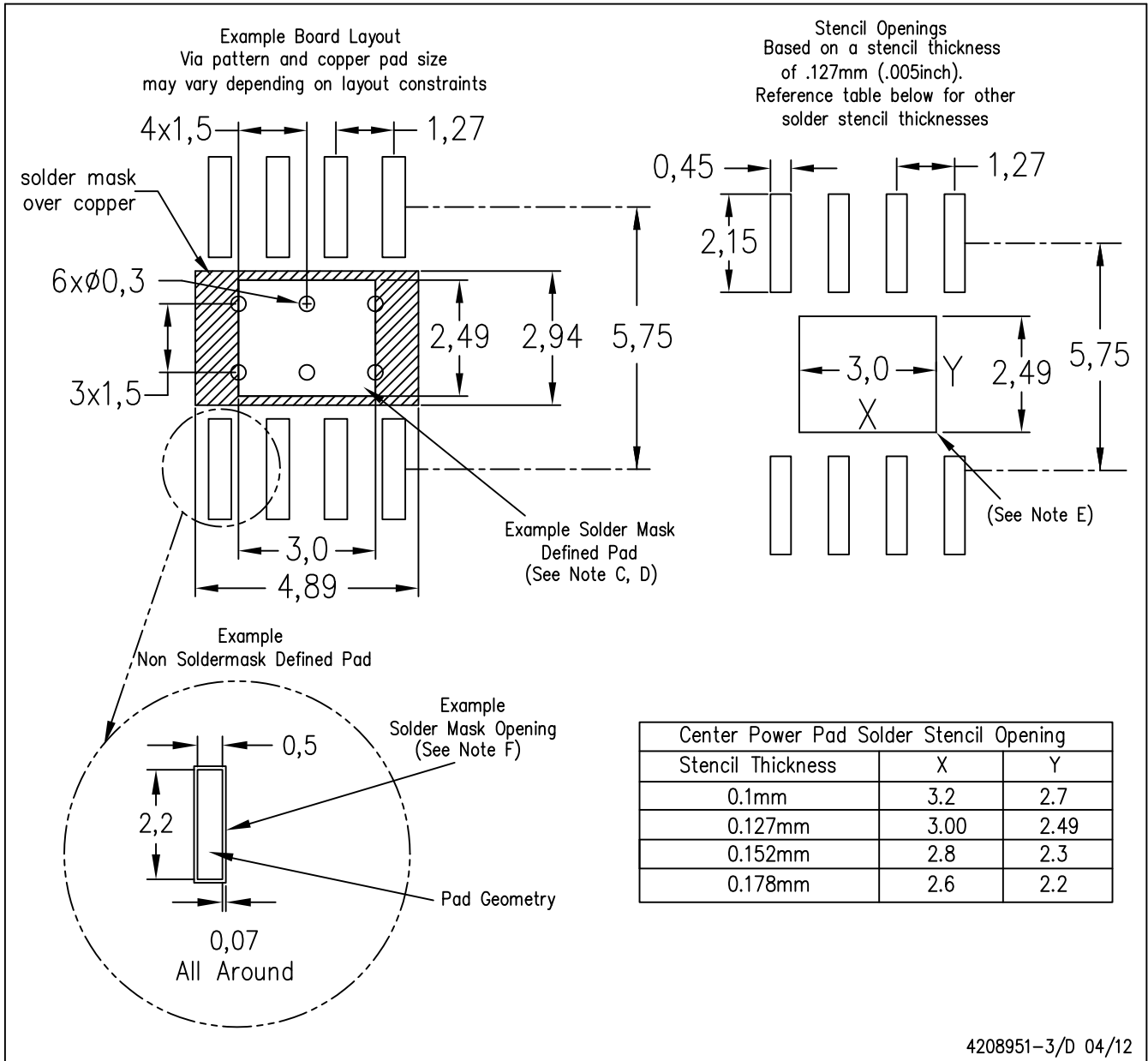

- NOTES:
- A. All linear dimensions are in millimeters.
 - B. This drawing is subject to change without notice.
 - C. Customers should place a note on the circuit board fabrication drawing not to alter the center solder mask defined pad.
 - D. This package is designed to be soldered to a thermal pad on the board. Refer to Technical Brief, PowerPad Thermally Enhanced Package, Texas Instruments Literature No. SLMA002, SLMA004, and also the Product Data Sheets for specific thermal information, via requirements, and recommended board layout. These documents are available at www.ti.com <<http://www.ti.com>>. Publication IPC-7351 is recommended for alternate designs.
 - E. Laser cutting apertures with trapezoidal walls and also rounding corners will offer better paste release. Customers should contact their board assembly site for stencil design recommendations. Example stencil design based on a 50% volumetric metal load solder paste. Refer to IPC-7525 for other stencil recommendations.
 - F. Customers should contact their board fabrication site for solder mask tolerances between and around signal pads.

PowerPAD is a trademark of Texas Instruments.

IMPORTANT NOTICE

Texas Instruments Incorporated and its subsidiaries (TI) reserve the right to make corrections, enhancements, improvements and other changes to its semiconductor products and services per JESD46C and to discontinue any product or service per JESD48B. Buyers should obtain the latest relevant information before placing orders and should verify that such information is current and complete. All semiconductor products (also referred to herein as "components") are sold subject to TI's terms and conditions of sale supplied at the time of order acknowledgment.

TI warrants performance of its components to the specifications applicable at the time of sale, in accordance with the warranty in TI's terms and conditions of sale of semiconductor products. Testing and other quality control techniques are used to the extent TI deems necessary to support this warranty. Except where mandated by applicable law, testing of all parameters of each component is not necessarily performed.

TI assumes no liability for applications assistance or the design of Buyers' products. Buyers are responsible for their products and applications using TI components. To minimize the risks associated with Buyers' products and applications, Buyers should provide adequate design and operating safeguards.

TI does not warrant or represent that any license, either express or implied, is granted under any patent right, copyright, mask work right, or other intellectual property right relating to any combination, machine, or process in which TI components or services are used. Information published by TI regarding third-party products or services does not constitute a license to use such products or services or a warranty or endorsement thereof. Use of such information may require a license from a third party under the patents or other intellectual property of the third party, or a license from TI under the patents or other intellectual property of TI.

Reproduction of significant portions of TI information in TI data books or data sheets is permissible only if reproduction is without alteration and is accompanied by all associated warranties, conditions, limitations, and notices. TI is not responsible or liable for such altered documentation. Information of third parties may be subject to additional restrictions.

Resale of TI components or services with statements different from or beyond the parameters stated by TI for that component or service voids all express and any implied warranties for the associated TI component or service and is an unfair and deceptive business practice. TI is not responsible or liable for any such statements.

Buyer acknowledges and agrees that it is solely responsible for compliance with all legal, regulatory and safety-related requirements concerning its products, and any use of TI components in its applications, notwithstanding any applications-related information or support that may be provided by TI. Buyer represents and agrees that it has all the necessary expertise to create and implement safeguards which anticipate dangerous consequences of failures, monitor failures and their consequences, lessen the likelihood of failures that might cause harm and take appropriate remedial actions. Buyer will fully indemnify TI and its representatives against any damages arising out of the use of any TI components in safety-critical applications.

In some cases, TI components may be promoted specifically to facilitate safety-related applications. With such components, TI's goal is to help enable customers to design and create their own end-product solutions that meet applicable functional safety standards and requirements. Nonetheless, such components are subject to these terms.

No TI components are authorized for use in FDA Class III (or similar life-critical medical equipment) unless authorized officers of the parties have executed a special agreement specifically governing such use.

Only those TI components which TI has specifically designated as military grade or "enhanced plastic" are designed and intended for use in military/aerospace applications or environments. Buyer acknowledges and agrees that any military or aerospace use of TI components which have **not** been so designated is solely at the Buyer's risk, and that Buyer is solely responsible for compliance with all legal and regulatory requirements in connection with such use.

TI has specifically designated certain components which meet ISO/TS16949 requirements, mainly for automotive use. Components which have not been so designated are neither designed nor intended for automotive use; and TI will not be responsible for any failure of such components to meet such requirements.

Products

Audio	www.ti.com/audio
Amplifiers	amplifier.ti.com
Data Converters	dataconverter.ti.com
DLP® Products	www.dlp.com
DSP	dsp.ti.com
Clocks and Timers	www.ti.com/clocks
Interface	interface.ti.com
Logic	logic.ti.com
Power Mgmt	power.ti.com
Microcontrollers	microcontroller.ti.com
RFID	www.ti-rfid.com
OMAP Mobile Processors	www.ti.com/omap
Wireless Connectivity	www.ti.com/wirelessconnectivity

Applications

Automotive and Transportation	www.ti.com/automotive
Communications and Telecom	www.ti.com/communications
Computers and Peripherals	www.ti.com/computers
Consumer Electronics	www.ti.com/consumer-apps
Energy and Lighting	www.ti.com/energy
Industrial	www.ti.com/industrial
Medical	www.ti.com/medical
Security	www.ti.com/security
Space, Avionics and Defense	www.ti.com/space-avionics-defense
Video and Imaging	www.ti.com/video

TI E2E Community e2e.ti.com

AMEYA360

Components Supply Platform

Authorized Distribution Brand :



Website :

Welcome to visit www.ameya360.com

Contact Us :

➤ Address :

401 Building No.5, JiuGe Business Center, Lane 2301, Yishan Rd
Minhang District, Shanghai , China

➤ Sales :

Direct +86 (21) 6401-6692

Email amall@ameya360.com

QQ 800077892

Skype [ameyasales1](#) [ameyasales2](#)

➤ Customer Service :

Email service@ameya360.com

➤ Partnership :

Tel +86 (21) 64016692-8333

Email mkt@ameya360.com