

Features

- Very high speed: 45 ns
 - Wide voltage range: 2.20 V to 3.60 V
- Pin compatible with CY62138CV30
- Ultra low standby power
 - Typical standby current: 1 μ A
 - Maximum standby current: 7 μ A
- Ultra low active power
 - Typical active current: 2 mA at $f = 1$ MHz
- Easy memory expansion with \overline{CE} and \overline{OE} features
- Automatic power down when deselected
- Complementary metal oxide semiconductor (CMOS) for optimum speed and power
- Offered in Pb-free 36-ball ball grid array (BGA) package

Functional Description

The CY62138EV30 is a high performance CMOS static RAM organized as 256K words by eight bits. This device features advanced circuit design to provide ultra low active current. This is ideal for providing More Battery Life™ (MoBL[®]) in portable applications such as cellular telephones. The device also has an automatic power down feature that significantly reduces power consumption. The device can be put into standby mode reducing power consumption when deselected (\overline{CE} HIGH).

Writing to the device is accomplished by taking Chip Enable (\overline{CE}) and Write Enable (\overline{WE}) inputs LOW. Data on the eight I/O pins (I/O_0 through I/O_7) is then written into the location specified on the address pins (A_0 through A_{18}).

Reading from the device is accomplished by taking Chip Enable (\overline{CE}) and Output Enable (\overline{OE}) LOW while forcing Write Enable (\overline{WE}) HIGH. Under these conditions, the contents of the memory location specified by the address pins appear on the I/O pins.

The eight input and output pins (I/O_0 through I/O_7) are placed in a high impedance state when the device is deselected (\overline{CE} HIGH), the outputs are disabled (\overline{OE} HIGH), or during a write operation (\overline{CE} LOW and \overline{WE} LOW).

For a complete list of related documentation, [click here](#).

Logic Block Diagram

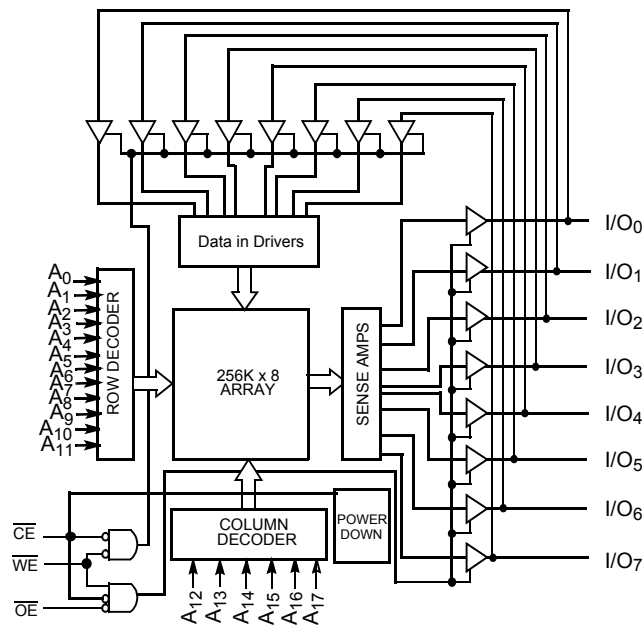

Contents

Pin Configuration	3	Ordering Information	12
Product Portfolio	3	Ordering Code Definitions	12
Maximum Ratings	4	Package Diagram	13
Operating Range	4	Acronyms	14
Electrical Characteristics	4	Document Conventions	14
Capacitance	5	Units of Measure	14
Thermal Resistance	5	Document History Page	15
AC Test Loads and Waveforms	5	Sales, Solutions, and Legal Information	16
Data Retention Characteristics	6	Worldwide Sales and Design Support	16
Data Retention Waveform	6	Products	16
Switching Characteristics	7	PSoC® Solutions	16
Switching Waveforms	8	Cypress Developer Community	16
Truth Table	11	Technical Support	16

Pin Configuration

Figure 1. 36-ball FBGA pinout (Top View) [1]

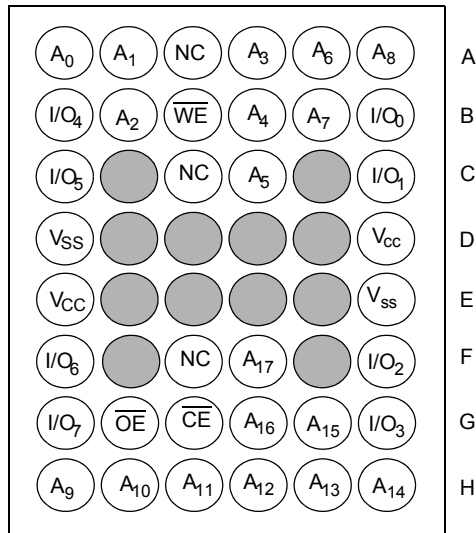

Product Portfolio

Product	V _{CC} Range (V)			Speed (ns)	Power Dissipation					
					Operating I _{CC} (mA)				Standby I _{SB2} (μA)	
	f = 1 MHz		f = f _{max}							
	Min	Typ [2]	Max		Typ [2]	Max	Typ [2]	Max	Typ [2]	Max
CY62138EV30LL	2.2	3.0	3.6	45	2	2.5	15	20	1	7

Notes

1. NC pins are not connected on the die.
2. Typical values are included for reference only and are not guaranteed or tested. Typical values are measured at V_{CC} = V_{CC(typ.)}, T_A = 25 °C.

Maximum Ratings

Exceeding the maximum ratings may impair the useful life of the device. These user guidelines are not tested.

Storage temperature -65 °C to +150 °C

Ambient temperature with power applied 55 °C to +125 °C

Supply voltage to ground potential -0.3 V to $V_{CC(MAX)} + 0.3$ V

DC voltage applied to outputs in High Z state ^[3, 4] -0.3 V to $V_{CC(MAX)} + 0.3$ V

DC input voltage ^[3, 4] -0.3 V to $V_{CC(MAX)} + 0.3$ V

Output current into outputs (LOW) 20 mA

Static discharge voltage > 2001 V (per MIL-STD-883, Method 3015)

Latch-up current > 200 mA

Operating Range

Product	Range	Ambient Temperature	V_{CC} ^[5]
CY62138EV30LL	Industrial	-40 °C to +85 °C	2.2 V to 3.6 V

Electrical Characteristics

Over the Operating Range

Parameter	Description	Test Conditions	CY62138EV30-45			Unit
			Min	Typ ^[6]	Max	
V_{OH}	Output HIGH voltage	$I_{OH} = -0.1$ mA, $V_{CC} = 2.20$ V	2.0	–	–	V
		$I_{OH} = -1.0$ mA, $V_{CC} = 2.70$ V	2.4	–	–	V
V_{OL}	Output LOW voltage	$I_{OL} = 0.1$ mA, $V_{CC} = 2.20$ V	–	–	0.4	V
		$I_{OL} = 2.1$ mA, $V_{CC} = 2.70$ V	–	–	0.4	V
V_{IH}	Input HIGH voltage	$V_{CC} = 2.2$ V to 2.7 V	1.8	–	$V_{CC} + 0.3$	V
		$V_{CC} = 2.7$ V to 3.6 V	2.2	–	$V_{CC} + 0.3$	V
V_{IL}	Input LOW voltage	$V_{CC} = 2.2$ V to 2.7 V	-0.3	–	0.6	V
		$V_{CC} = 2.7$ V to 3.6 V	-0.3	–	0.8	V
I_{IX}	Input leakage current	$GND \leq V_I \leq V_{CC}$	-1	–	+1	μ A
I_{OZ}	Output leakage current	$GND \leq V_O \leq V_{CC}$, Output disabled	-1	–	+1	μ A
I_{CC}	V_{CC} Operating supply current	$f = f_{max} = 1/t_{RC}$, $V_{CC} = V_{CCmax}$, $I_{OUT} = 0$ mA, CMOS levels	–	15	20	mA
		$f = 1$ MHz	–	2	2.5	mA
I_{SB1} ^[7]	Automatic CE power down current – CMOS inputs	$\overline{CE} \geq V_{CC} - 0.2$ V, $V_{IN} \geq V_{CC} - 0.2$ V, $V_{IN} \leq 0.2$ V, $f = f_{max}$ (Address and data only), $f = 0$ (OE, and WE), $V_{CC} = 3.60$ V	–	1	7	μ A
I_{SB2} ^[7]	Automatic CE power down current – CMOS inputs	$\overline{CE} \geq V_{CC} - 0.2$ V, $V_{IN} \geq V_{CC} - 0.2$ V or $V_{IN} \leq 0.2$ V, $f = 0$, $V_{CC} = 3.60$ V	–	1	7	μ A

Notes

- $V_{IL(min.)} = -2.0$ V for pulse durations less than 20 ns.
- $V_{IH(max.)} = V_{CC} + 0.75$ V for pulse durations less than 20 ns.
- Full device AC operation assumes a 100 μ s ramp time from 0 to $V_{CC(min.)}$ and 200 μ s wait time after V_{CC} stabilization.
- Typical values are included for reference only and are not guaranteed or tested. Typical values are measured at $V_{CC} = V_{CC(typ.)}$, $T_A = 25$ °C.
- Chip enable (\overline{CE}) must be tied to CMOS levels to meet the $I_{SB1} / I_{SB2} / I_{CCDR}$ specification. Other inputs can be left floating.

Capacitance

Parameter [8]	Description	Test Conditions	Max	Unit
C _{IN}	Input capacitance	T _A = 25 °C, f = 1 MHz, V _{CC} = V _{CC(typ.)}	10	pF
C _{OUT}	Output capacitance		10	pF

Thermal Resistance

Parameter [8]	Description	Test Conditions	36-ball BGA	Unit
θ _{JA}	Thermal resistance (junction to ambient)	Still air, soldered on a 3 × 4.5 inch, four-layer printed circuit board	72	°C/W
θ _{JC}	Thermal resistance (junction to case)		8.86	°C/W

AC Test Loads and Waveforms

Figure 2. AC Test Loads and Waveforms

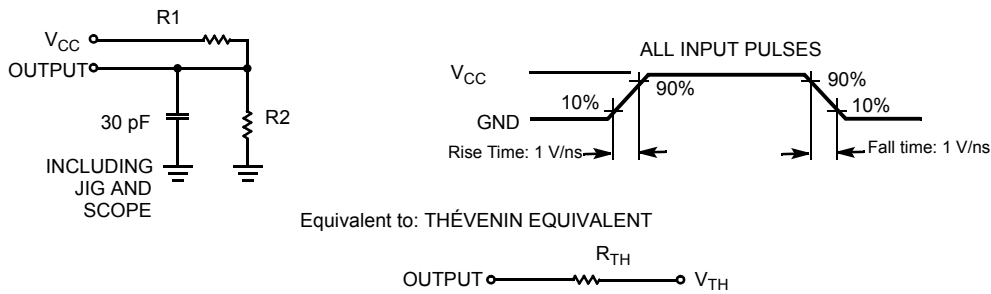

Parameters	2.50 V	3.0 V	Unit
R1	16667	1103	Ω
R2	15385	1554	Ω
R _{TH}	8000	645	Ω
V _{TH}	1.20	1.75	V

Note

8. Tested initially and after any design or process changes that may affect these parameters.

Data Retention Characteristics

Over the Operating Range

Parameter	Description	Conditions	Min	Typ ^[9]	Max	Unit
V_{DR}	V_{CC} for data retention		1	–	–	V
I_{CCDR} ^[10]	Data retention current	$V_{CC} = 1\text{ V}$, $\overline{CE} \geq V_{CC} - 0.2\text{ V}$, $V_{IN} \geq V_{CC} - 0.2\text{ V}$ or $V_{IN} \leq 0.2\text{ V}$	–	0.8	3	μA
t_{CDR} ^[11]	Chip deselect to data retention time		0	–	–	ns
t_R ^[12]	Operation recovery time		45	–	–	ns

Data Retention Waveform

Figure 3. Data Retention Waveform

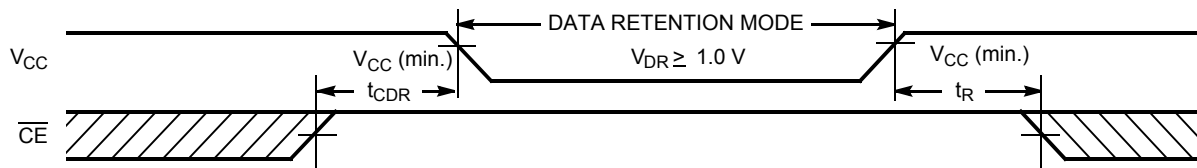

Notes

- 9. Typical values are included for reference only and are not guaranteed or tested. Typical values are measured at $V_{CC} = V_{CC(typ)}$, $T_A = 25\text{ }^\circ\text{C}$.
- 10. Chip enable (\overline{CE}) must be tied to CMOS levels to meet the I_{SB1} / I_{SB2} / I_{CCDR} specification. Other inputs can be left floating.
- 11. Tested initially and after any design or process changes that may affect these parameters.
- 12. Full device AC operation requires linear V_{CC} ramp from V_{DR} to $V_{CC(min.)} \geq 100\text{ }\mu\text{s}$ or stable at $V_{CC(min.)} \geq 100\text{ }\mu\text{s}$.

Switching Characteristics

Over the Operating Range

Parameter ^[13, 14]	Description	45 ns		Unit
		Min	Max	
Read Cycle				
t_{RC}	Read cycle time	45	–	ns
t_{AA}	Address to data valid	–	45	ns
t_{OHA}	Data hold from address change	10	–	ns
t_{ACE}	\overline{CE} LOW to data valid	–	45	ns
t_{DOE}	\overline{OE} LOW to data valid	–	22	ns
t_{LZOE}	\overline{OE} LOW to Low Z ^[15]	5	–	ns
t_{HZOE}	\overline{OE} HIGH to High Z ^[15, 16]	–	18	ns
t_{LZCE}	\overline{CE} LOW to Low Z ^[15]	10	–	ns
t_{HZCE}	\overline{CE} HIGH to High Z ^[15, 16]	–	18	ns
t_{PU}	\overline{CE} LOW to power-up	0	–	ns
t_{PD}	\overline{CE} HIGH to power-up	–	45	ns
Write Cycle ^[17]				
t_{WC}	Write cycle time	45	–	ns
t_{SCE}	\overline{CE} LOW to write end	35	–	ns
t_{AW}	Address setup to write end	35	–	ns
t_{HA}	Address hold from write end	0	–	ns
t_{SA}	Address setup to write start	0	–	ns
t_{PWE}	\overline{WE} pulse width	35	–	ns
t_{SD}	Data setup to write end	25	–	ns
t_{HD}	Data hold from write end	0	–	ns
t_{HZWE}	\overline{WE} LOW to High Z ^[15, 16]	–	18	ns
t_{LZWE}	\overline{WE} HIGH to Low Z ^[15]	10	–	ns

Notes

13. In an earlier revision of this device, under a specific application condition, READ and WRITE operations were limited to switching of the chip enable signal as described in the Application Note AN66311. However, the issue has been fixed and in production now, and hence, this Application Notes is no longer applicable. It is available for download on our website as it contains information on the date code of the parts, beyond which the fix has been in production.

14. Test conditions for all parameters other than three-state parameters assume signal transition time of 3 ns or less (1 V/ns), timing reference levels of $V_{CC(typ)}/2$, input pulse levels of 0 to $V_{CC(typ)}$, and output loading of the specified I_{OL}/I_{OH} as shown in Figure 2 on page 5.

15. At any given temperature and voltage condition, t_{HZCE} is less than t_{LZCE} , t_{HZOE} is less than t_{LZOE} , and t_{HZWE} is less than t_{LZWE} for any given device.

16. t_{HZOE} , t_{HZCE} , and t_{HZWE} transitions are measured when the output enter a high impedance state.

17. The internal write time of the memory is defined by the overlap of \overline{WE} , $\overline{CE} = V_{IL}$. All signals must be ACTIVE to initiate a write and any of these signals can terminate a write by going INACTIVE. The data input set-up and hold timing should be referenced to the edge of the signal that terminates the write.

Switching Waveforms

Figure 4. Read Cycle No. 1: Address Transition Controlled [18, 19]

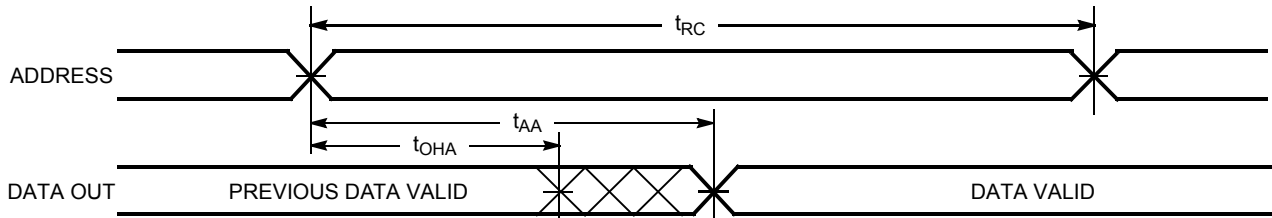
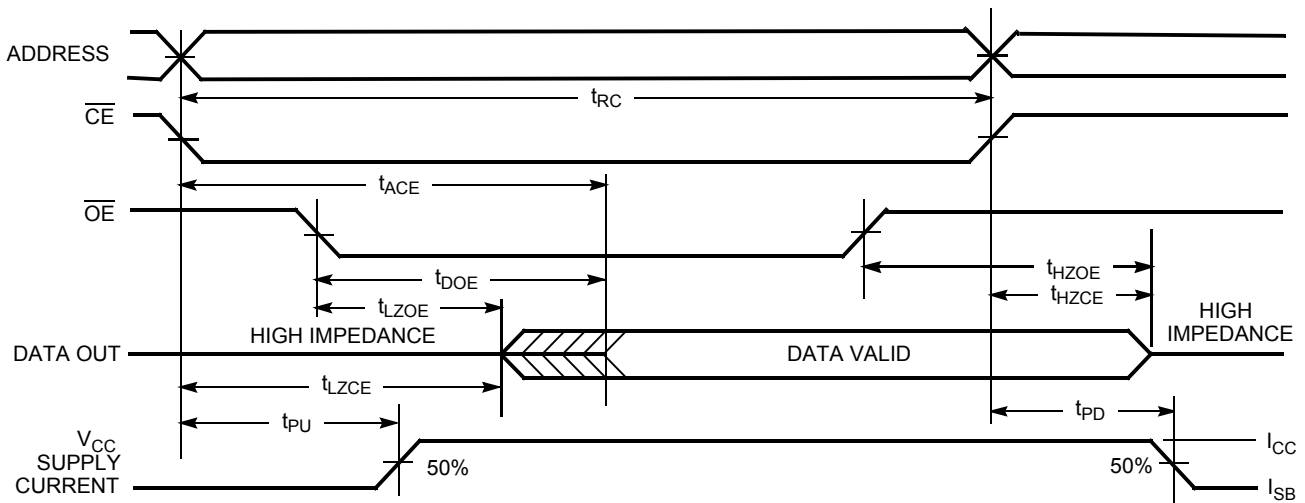

Figure 5. Read Cycle No. 2: \overline{OE} Controlled [20, 21]



Notes

18. Device is continuously selected. \overline{OE} , $\overline{CE} = V_{IL}$.
19. \overline{WE} is HIGH for read cycle.
20. \overline{WE} is HIGH for read cycle.
21. Address valid prior to or coincident with \overline{CE} transition LOW.

Switching Waveforms (continued)

Figure 6. Write Cycle No. 1: \overline{WE} Controlled [22, 23]

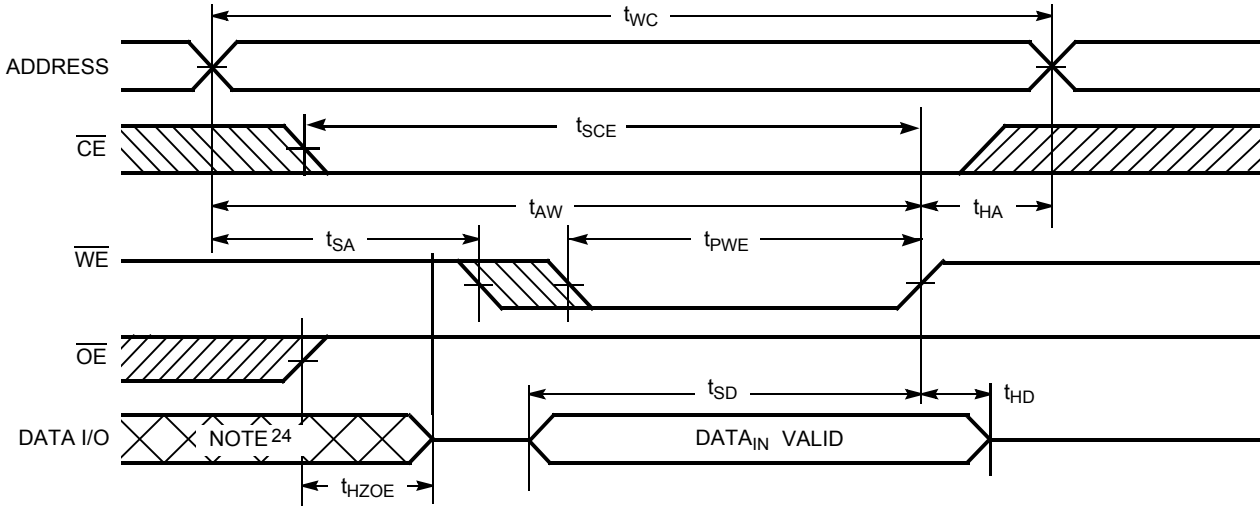
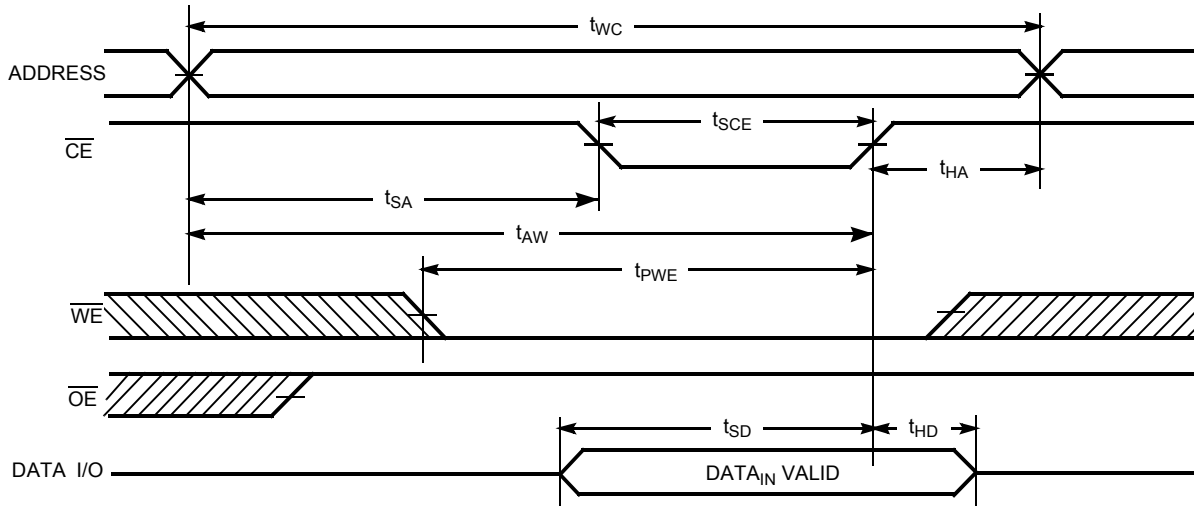

Figure 7. Write Cycle No. 2: \overline{CE} Controlled [22, 23]



Notes

- 22. Data I/O is high impedance if $\overline{OE} = V_{IH}$.
- 23. If \overline{CE} goes HIGH simultaneously with \overline{WE} HIGH, the output remains in high impedance state.
- 24. During this period, the I/Os are in output state and input signals should not be applied.

Switching Waveforms (continued)

Figure 8. Write Cycle No. 3: \overline{WE} Controlled, \overline{OE} LOW ^[25]

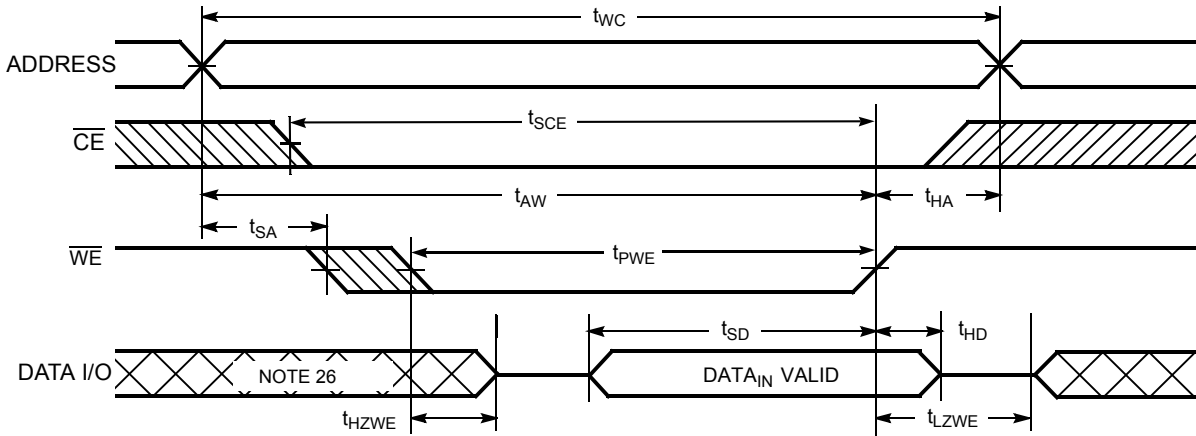

Notes

- 25. If \overline{CE} goes HIGH simultaneously with \overline{WE} HIGH, the output remains in high impedance state.
- 26. During this period, the I/Os are in output state and input signals should not be applied.

Truth Table

$\overline{\text{CE}}$	$\overline{\text{WE}}$	$\overline{\text{OE}}$	Inputs/Outputs	Mode	Power
H ^[27]	X	X	High Z	Deselect/power-down	Standby (I_{SB})
L	H	L	Data out (I/O_0 – I/O_7)	Read	Active (I_{CC})
L	H	H	High Z	Output disabled	Active (I_{CC})
L	L	X	Data in (I/O_0 – I/O_7)	Write	Active (I_{CC})

Note

27. Chip enable ($\overline{\text{CE}}$) must be tied to CMOS levels to meet the $I_{\text{SB}1}$ / $I_{\text{SB}2}$ / I_{CCDR} specification. Other inputs can be left floating.

Ordering Information

Speed (ns)	Ordering Code	Package Diagram	Package Type	Operating Range
45	CY62138EV30LL-45BVXI	51-85149	36-ball VFBGA (6 mm × 8 mm × 1 mm) (Pb-free)	Industrial

Ordering Code Definitions

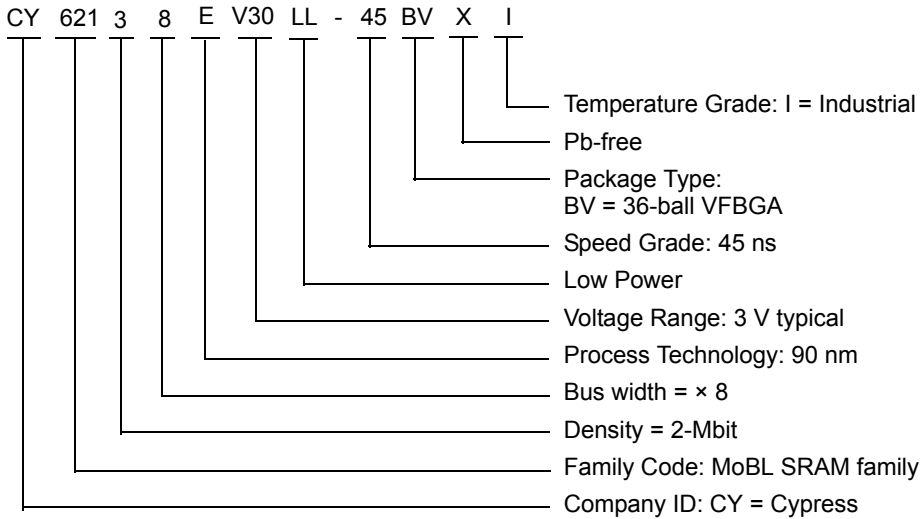

Package Diagram

Figure 9. 36-ball VFBGA (6 × 8 × 1.0 mm) BV36A Package Outline, 51-85149

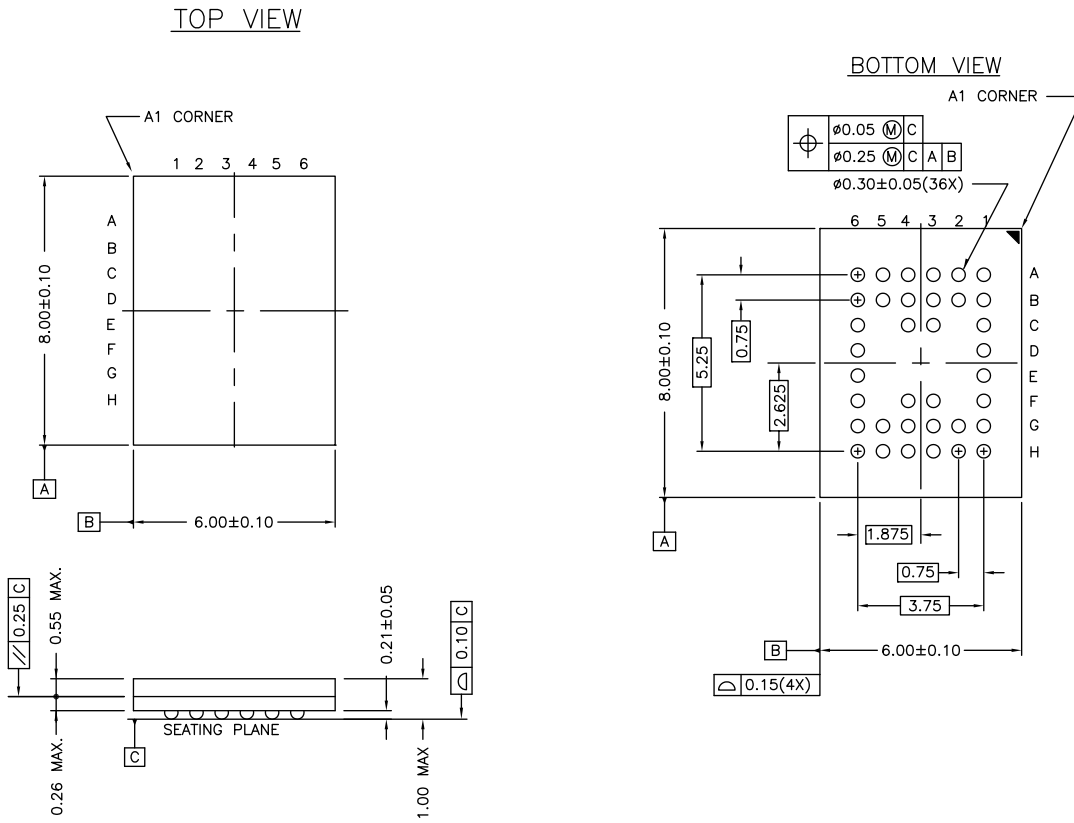

51-85149 *E

Acronyms

Acronym	Description
BGA	ball grid array
CE	chip enable
CMOS	complementary metal oxide semiconductor
FBGA	fine-pitch ball grid array
I/O	input/output
OE	output enable
SRAM	static random access memory
VFBGA	very fine ball grid array
WE	write enable

Document Conventions

Units of Measure

Symbol	Unit of Measure
°C	degree Celsius
MHz	megahertz
μA	microampere
μs	microsecond
mA	milliampere
mm	millimeter
ns	nanosecond
pF	picofarad
Ω	ohm
V	volt
W	watt

Document History Page

Document Title: CY62138EV30 MoBL [®] , 2-Mbit (256 K × 8) MoBL [®] Static RAM				
Document Number: 38-05577				
Rev.	ECN No.	Orig. of Change	Submission Date	Description of Change
**	237432	AJU	See ECN	New data sheet
*A	427817	NXR	See ECN	<p>Removed 35 ns Speed Bin</p> <p>Removed "L" version</p> <p>Removed 32-pin TSOPII package from product Offering.</p> <p>Changed ball C3 from DNU to NC.</p> <p>Removed the redundant footnote on DNU.</p> <p>Moved Product Portfolio from Page # 3 to Page #2.</p> <p>Changed I_{CC} (Max) value from 2 mA to 2.5 mA and I_{CC} (Typ) value from 1.5 mA to 2 mA at f = 1 MHz</p> <p>Changed I_{CC} (Typ) value from 12 mA to 15 mA at f = f_{max}=1/t_{RC}</p> <p>Changed I_{SB1} and I_{SB2} Typ. values from 0.7 μA to 1 μA and Max. values from 2.5 μA to 7 μA.</p> <p>Changed V_{CC} stabilization time in footnote #7 from 100 μs to 200 μs</p> <p>Changed the AC test load capacitance from 50pF to 30pF on Page# 4</p> <p>Changed V_{DR} from 1.5V to 1V on Page# 4.</p> <p>Changed I_{CCDR} from 1 μA to 3 μA in the Data Retention Characteristics table on Page # 4.</p> <p>Corrected t_R in Data Retention Characteristics from 100 μs to t_{RC} ns</p> <p>Changed t_{OHA}, t_{LZCE}, t_{LZWE} from 6 ns to 10 ns</p> <p>Changed t_{HZOE}, t_{HZCE}, t_{HZWE} from 15 ns to 18 ns</p> <p>Changed t_{LZOE} from 3 ns to 5 ns</p> <p>Changed t_{SCE} and t_{AW} from 40 ns to 35 ns</p> <p>Changed t_{SD} from 20 ns to 25 ns</p> <p>Changed t_{PWE} from 25 ns to 35 ns</p> <p>Updated the Ordering Information table and replaced Package Name column with Package Diagram.</p>
*B	2604685	VKN / PYRS	11/12/08	Added footnote 7 related to I _{SB2} and I _{CCDR}
*C	3143896	RAME	01/17/2011	<p>Updated Datasheet as per new template</p> <p>Added Ordering Code Definitions</p> <p>Added Acronyms and Units of Measure table</p> <p>Converted all tablenotes to Footnote</p> <p>Updated Package Diagram 51-85149 from *C to *D</p>
*D	3284728	AJU	06/16/2011	<p>Removed the Note "For best practice recommendations, refer to the Cypress application note "SRAM System Design Guidelines" on http://www.cypress.com." in page 1 and its reference in Functional Description.</p> <p>Updated in new template.</p>
*E	3806123	TAVA	11/08/2012	<p>Updated Data Retention Waveform (Updated Figure 3 (Changed "V_{DR} ≥ 1.5 V" to "V_{DR} ≥ 1.0 V")).</p> <p>Updated Package Diagram (spec 51-85149 (Changed revision from *D to *E)).</p>
*F	4099016	VINI	08/19/2013	<p>Updated Switching Characteristics:</p> <p>Added Note 13 and referred the same note in "Parameter" column.</p> <p>Updated in new template.</p> <p>Completing Sunset Review.</p>
*G	4576475	VINI	11/19/2014	Added related documentation hyperlink in page 1.

Sales, Solutions, and Legal Information

Worldwide Sales and Design Support

Cypress maintains a worldwide network of offices, solution centers, manufacturer's representatives, and distributors. To find the office closest to you, visit us at [Cypress Locations](#).

Products

Automotive	cypress.com/go/automotive
Clocks & Buffers	cypress.com/go/clocks
Interface	cypress.com/go/interface
Lighting & Power Control	cypress.com/go/powerpsoc cypress.com/go/plc
Memory	cypress.com/go/memory
PSoC	cypress.com/go/psoc
Touch Sensing	cypress.com/go/touch
USB Controllers	cypress.com/go/USB
Wireless/RF	cypress.com/go/wireless

PSoC[®] Solutions

psoc.cypress.com/solutions
PSoC 1 | PSoC 3 | PSoC 4 | PSoC 5LP

Cypress Developer Community

[Community](#) | [Forums](#) | [Blogs](#) | [Video](#) | [Training](#)

Technical Support

cypress.com/go/support

© Cypress Semiconductor Corporation, 2004-2014. The information contained herein is subject to change without notice. Cypress Semiconductor Corporation assumes no responsibility for the use of any circuitry other than circuitry embodied in a Cypress product. Nor does it convey or imply any license under patent or other rights. Cypress products are not warranted nor intended to be used for medical, life support, life saving, critical control or safety applications, unless pursuant to an express written agreement with Cypress. Furthermore, Cypress does not authorize its products for use as critical components in life-support systems where a malfunction or failure may reasonably be expected to result in significant injury to the user. The inclusion of Cypress products in life-support systems application implies that the manufacturer assumes all risk of such use and in doing so indemnifies Cypress against all charges.

Any Source Code (software and/or firmware) is owned by Cypress Semiconductor Corporation (Cypress) and is protected by and subject to worldwide patent protection (United States and foreign), United States copyright laws and international treaty provisions. Cypress hereby grants to licensee a personal, non-exclusive, non-transferable license to copy, use, modify, create derivative works of, and compile the Cypress Source Code and derivative works for the sole purpose of creating custom software and or firmware in support of licensee product to be used only in conjunction with a Cypress integrated circuit as specified in the applicable agreement. Any reproduction, modification, translation, compilation, or representation of this Source Code except as specified above is prohibited without the express written permission of Cypress.

Disclaimer: CYPRESS MAKES NO WARRANTY OF ANY KIND, EXPRESS OR IMPLIED, WITH REGARD TO THIS MATERIAL, INCLUDING, BUT NOT LIMITED TO, THE IMPLIED WARRANTIES OF MERCHANTABILITY AND FITNESS FOR A PARTICULAR PURPOSE. Cypress reserves the right to make changes without further notice to the materials described herein. Cypress does not assume any liability arising out of the application or use of any product or circuit described herein. Cypress does not authorize its products for use as critical components in life-support systems where a malfunction or failure may reasonably be expected to result in significant injury to the user. The inclusion of Cypress' product in a life-support systems application implies that the manufacturer assumes all risk of such use and in doing so indemnifies Cypress against all charges.

Use may be limited by and subject to the applicable Cypress software license agreement.

AMEYA360

Components Supply Platform

Authorized Distribution Brand :



Website :

Welcome to visit www.ameya360.com

Contact Us :

➤ Address :

401 Building No.5, JiuGe Business Center, Lane 2301, Yishan Rd
Minhang District, Shanghai , China

➤ Sales :

Direct +86 (21) 6401-6692

Email amall@ameya360.com

QQ 800077892

Skype [ameyasales1](#) [ameyasales2](#)

➤ Customer Service :

Email service@ameya360.com

➤ Partnership :

Tel +86 (21) 64016692-8333

Email mkt@ameya360.com