

**C×R type, VSSOP package,
60V and 100 V load voltage**

**PhotoMOS®
RF VSSOP 1 Form A C×R
(AQY22○○○T)**

New



mm inch

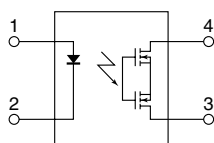

RoHS compliant

FEATURES

1. Miniature VSSOP package

4.6 mm² mounting area achieved. Approx 29% less than previous product (SON type).

Contributes to the miniaturization of instruments and higher density mounting.

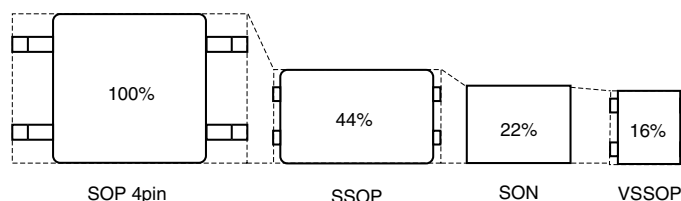

2. Load voltage: 60 V and 100 V

3. Low C×R

Low on resistance and low output capacitance available

• 60 V load voltage: AQY222R2T

Output capacitance: 27 pF (typical), On resistance: 0.8Ω (typical)

• 100 V load voltage: AQY225R3T

Output capacitance: 5.8 pF (typical), On resistance: 8.8Ω (typical)

TYPICAL APPLICATIONS

1. Measuring and testing equipment

IC tester, Probe card, Board tester and other testing equipment

2. Telecommunication equipment

*Does not support automotive applications.

TYPES

Type	Output rating*1		Part No. (Tape and reel packing style)*2		Packing quantity in the tape and reel
	Load voltage	Load current	Picked from the 1 and 4-pin side	Picked from the 2 and 3-pin side	
AC/DC dual use	New 60 V	400 mA	AQY222R2TY	AQY222R2TW	1,000 pcs.
	New 100 V	120 mA	AQY225R3TY	AQY225R3TW	

Notes: *1. Indicate the peak AC and DC values.

*2. Only tape and reel package is available.

For space reasons, only "2R2" or "5R3" is marked on the product as the part number.

RATING

1. Absolute maximum ratings (Ambient temperature: 25°C 77°F)

Item		Symbol	AQY222R2T	AQY225R3T	Remarks
Input side	LED forward current	I_F	50 mA		
	LED reverse voltage	V_R	5 V		
	Peak forward current	I_{FP}	1 A		f = 100 Hz, Duty factor = 0.1%
	Power dissipation	P_{in}	75 mW		
Output side	Load voltage (peak AC)	V_L	60 V	100 V	
	Continuous load current	I_L	0.4 A	0.12 A	Peak AC, DC
	Peak load current	I_{peak}	1.2 A	0.3 A	100 ms (1shot), $V_L = DC$
	Power dissipation	P_{out}	250 mW		
Total power dissipation		P_T	300 mW		
I/O isolation voltage		V_{iso}	200 V AC		
Operating temperature		T_{opr}	-40°C to +85°C -40°F to +185°F		Non-condensing at low temperatures
Storage temperature		T_{stg}	-40°C to +100°C -40°F to +212°F		

2. Electrical characteristics (Ambient temperature: 25°C 77°F)

Item			Symbol	AQY222R2T	AQY225R3T	Condition
Input	LED operate current	Typical	I_{Fon}	0.4 mA		AQY222R2T: $I_L = 400$ mA AQY225R3T: $I_L = 80$ mA
		Maximum		3 mA		
	LED turn off current	Minimum	I_{Foff}	0.1 mA		
		Typical		0.35 mA		
LED dropout voltage	Typical	V_F	1.14 V (1.35 V at $I_F = 50$ mA)		$I_F = 5$ mA	
	Maximum		1.5 V			
Output	On resistance	Typical	R_{on}	0.8 Ω	8.8 Ω	AQY222R2T: $I_F = 5$ mA, $I_L = 400$ mA AQY225R3T: $I_F = 5$ mA, $I_L = 80$ mA Within 1 s on time
		Maximum		1.25 Ω	14 Ω	
	Output capacitance	Typical	C_{out}	27 pF	5.8 pF	$I_F = 0$ mA, $V_B = 0$ V, f = 1 MHz
		Maximum		40 pF	8 pF	
Off state leakage current	Typical	I_{Leak}	—		$I_F = 0$ mA, $V_L = Max.$	
	Maximum		10 nA*			
Transfer characteristics	Turn on time**	Typical	T_{on}	0.12 ms	0.04 ms	AQY222R2T: $I_F = 5$ mA, $V_L = 10$ V, $R_L = 100$ Ω AQY225R3T: $I_F = 5$ mA, $V_L = 10$ V, $R_L = 125$ Ω
		Maximum		0.5 ms		
	Turn off time**	Typical	T_{off}	0.08 ms	0.05 ms	
		Maximum		0.2 ms		
I/O capacitance	Typical	C_{iso}	0.4 pF		f = 1 MHz, $V_B = 0$ V	
	Maximum		1.5 pF			

Notes: 1. Please refer to the "Schematic and Wiring Diagrams" for connection method.

2. Variation possible through combinations of output capacitance and on resistance. For more information, please contact our sales office in your area.

*Available as custom orders (1 nA or less)

**Turn on/Turn off time

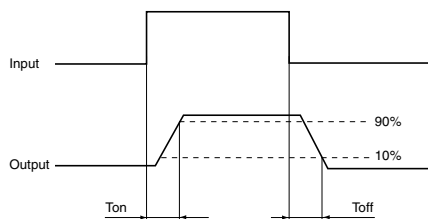

RECOMMENDED OPERATING CONDITIONS

Please obey the following conditions to ensure proper this device operation and resetting.

Item	Symbol	Recommended value	Unit
Input LED forward current	I_F	5	mA

■ For Dimensions, see Page 5.

■ For Schematic and Wiring Diagrams, see Page 5.

■ These products are not designed for automotive use.

If you are considering to use these products for automotive applications, please contact your local Panasonic Corporation technical representative.

REFERENCE DATA

1.-(1) Load current vs. ambient temperature characteristics

Allowable ambient temperature: -40°C to $+85^{\circ}\text{C}$
 -40°F to $+185^{\circ}\text{F}$

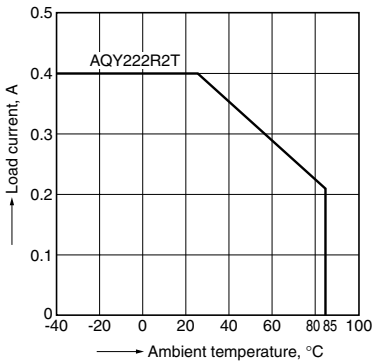

1.-(2) Load current vs. ambient temperature characteristics

Allowable ambient temperature: -40°C to $+85^{\circ}\text{C}$
 -40°F to $+185^{\circ}\text{F}$

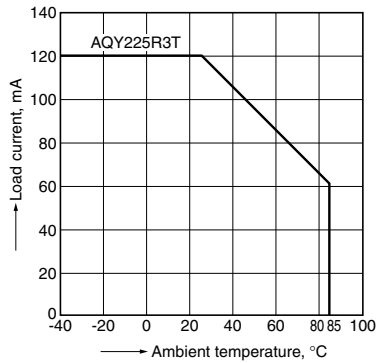

2.-(1) On resistance vs. ambient temperature characteristics

Measured portion: between terminals 3 and 4
 LED current: 5 mA; Load voltage: 10V (DC)
 Continuous load current: Max. (DC)

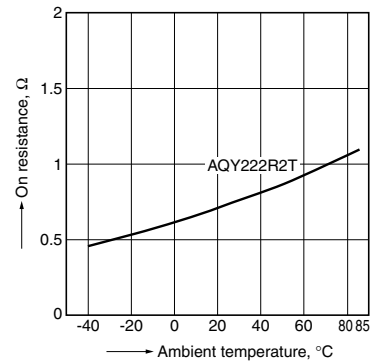

2.-(2) On resistance vs. ambient temperature characteristics

Measured portion: between terminals 3 and 4;
 LED current: 5 mA; Load voltage: 10V (DC);
 Continuous load current: 80mA (DC)

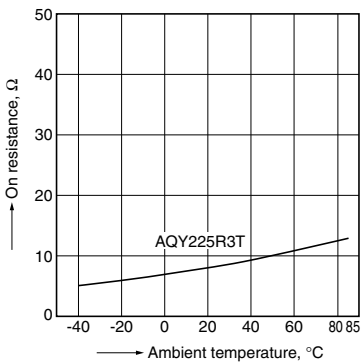

3.-(1) Turn on time vs. ambient temperature characteristics

LED current: 5 mA; Load voltage: 10V (DC);
 Continuous load current: 100mA (DC)

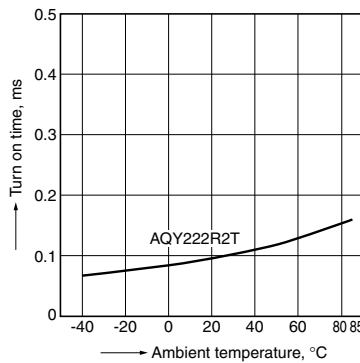

3.-(2) Turn on time vs. ambient temperature characteristics

LED current: 5 mA; Load voltage: 10V (DC);
 Continuous load current: 80mA (DC)

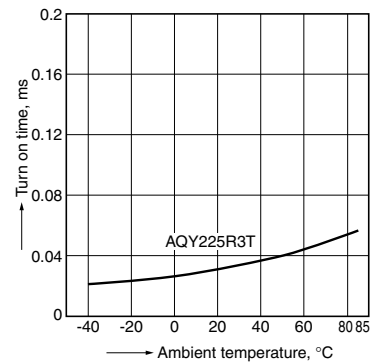

4.-(1) Turn off time vs. ambient temperature characteristics

LED current: 5 mA; Load voltage: 10V (DC);
 Continuous load current: 100mA (DC)

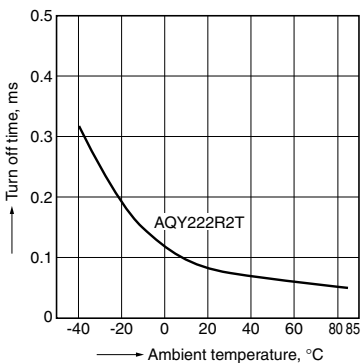

4.-(2) Turn off time vs. ambient temperature characteristics

LED current: 5 mA; Load voltage: 10V (DC);
 Continuous load current: 80mA (DC)

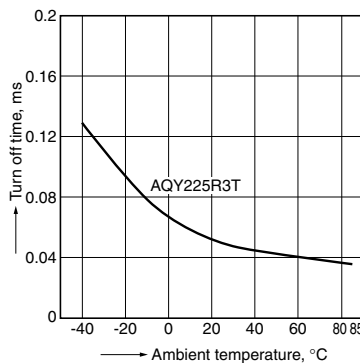

5.-(1) LED operate current vs. ambient temperature characteristics

Load voltage: 10V (DC);
 Continuous load current: 400mA (DC)

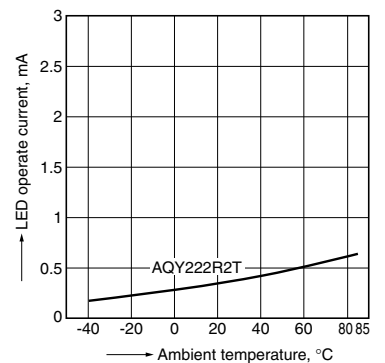

RF VSSOP 1 Form A CxR (AQY22000T)

5.-(2) LED operate current vs. ambient temperature characteristics

Load voltage: 10V (DC);
Continuous load current: 80mA (DC)

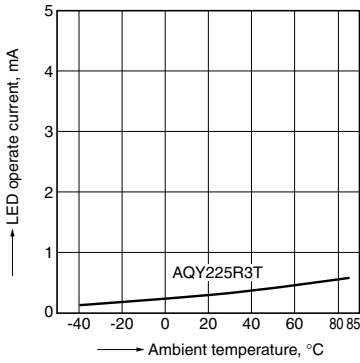

6.-(1) LED turn off current vs. ambient temperature characteristics

Load voltage: 10V (DC);
Continuous load current: 400mA (DC)

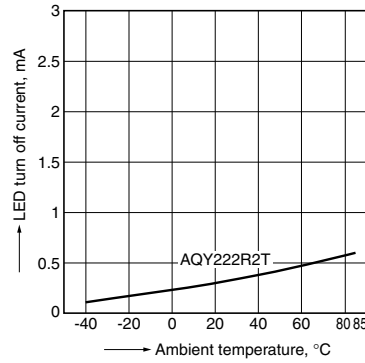

6.-(2) LED turn off current vs. ambient temperature characteristics

Load voltage: 10V (DC);
Continuous load current: 80mA (DC)

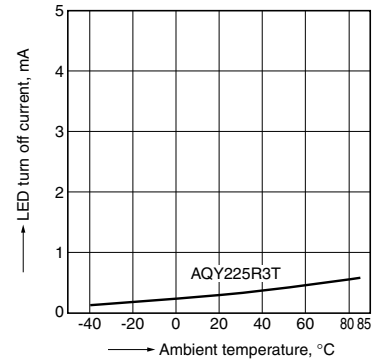

7. LED dropout voltage vs. ambient temperature characteristics

LED current: 5 to 50 mA

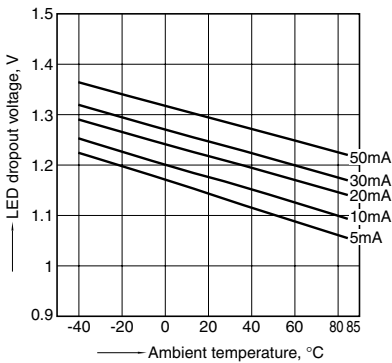

8.-(1) Current vs. voltage characteristics of output at MOS portion

Measured portion: between terminals 3 and 4;
Ambient temperature: 25°C 77°F

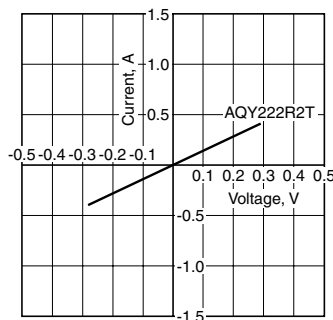

8.-(2) Current vs. voltage characteristics of output at MOS portion

Measured portion: between terminals 3 and 4;
Ambient temperature: 25°C 77°F

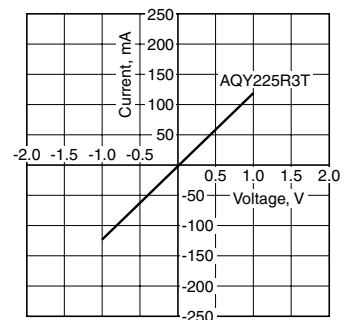

9.-(1) Off state leakage current vs. load voltage characteristics

Measured portion: between terminals 3 and 4;
Ambient temperature: 25°C 77°F

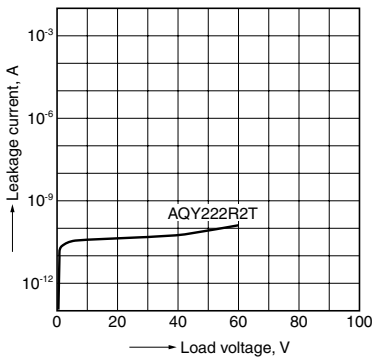

9.-(2) Off state leakage current vs. load voltage characteristics

Measured portion: between terminals 3 and 4;
Ambient temperature: 25°C 77°F

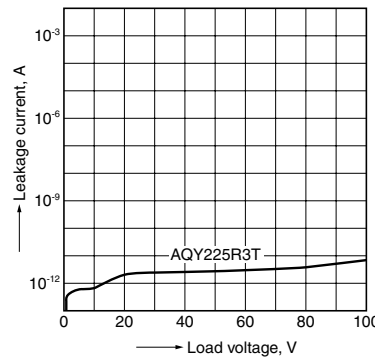

10.-(1) Turn on time vs. LED forward current characteristics

Measured portion: between terminals 3 and 4;
Load voltage: 10V (DC); Continuous load current: 100mA (DC); Ambient temperature: 25°C 77°F

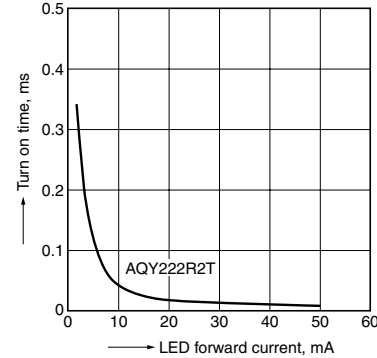

10.-(2) Turn on time vs. LED forward current characteristics

Measured portion: between terminals 3 and 4;
Load voltage: 10V (DC); Continuous load current: 80mA (DC); Ambient temperature: 25°C 77°F

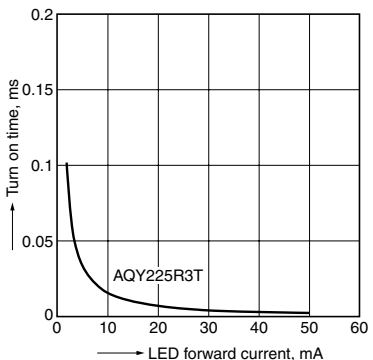

11.-(1) Turn off time vs. LED forward current characteristics

Measured portion: between terminals 3 and 4;
Load voltage: 10V (DC); Continuous load current: 100mA (DC); Ambient temperature: 25°C 77°F

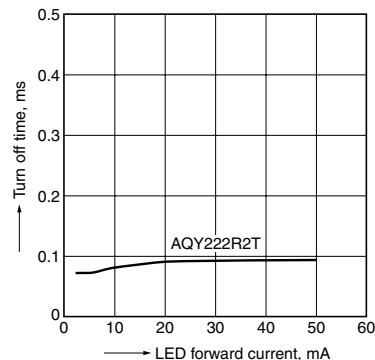

11.-(2) Turn off time vs. LED forward current characteristics

Measured portion: between terminals 3 and 4;
Load voltage: 10V (DC); Continuous load current: 80mA (DC); Ambient temperature: 25°C 77°F

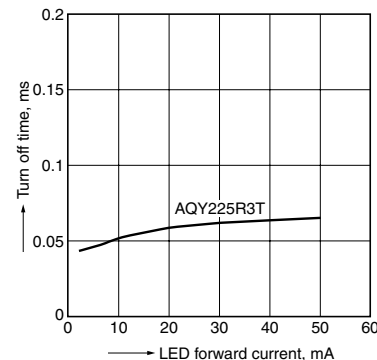

12.-(1) Output capacitance vs. applied voltage characteristics

Measured portion: between terminals 3 and 4;
Frequency: 1 MHz;
Ambient temperature: 25°C 77°F

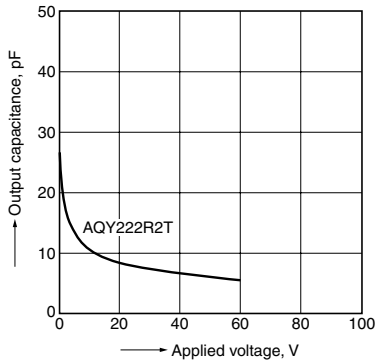

12.-(2) Output capacitance vs. applied voltage characteristics

Measured portion: between terminals 3 and 4;
Frequency: 1 MHz;
Ambient temperature: 25°C 77°F

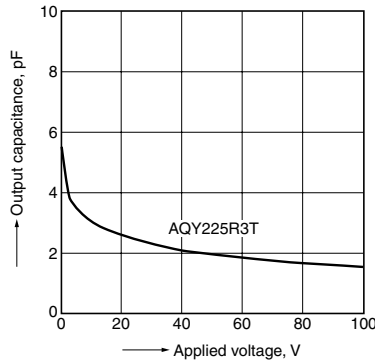

DIMENSIONS (mm inch)

The CAD data of the products with a **CAD Data** mark can be downloaded from: <http://industrial.panasonic.com/ac/e/>

External dimensions

Recommended mounting pad (Top view)



CAD Data

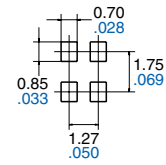
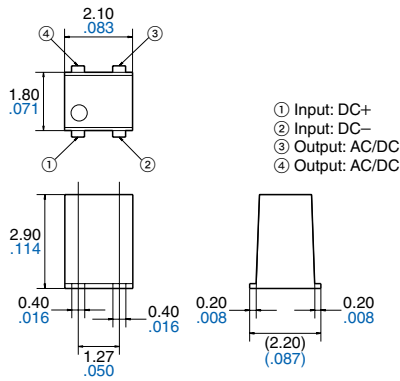

Tolerance: $\pm 0.1 \pm .004$

General tolerance: $\pm 0.1 \pm .004$

SCHEMATIC AND WIRING DIAGRAMS

E_i: Power source at input side, I_F: LED forward current, V_L: Load voltage, I_L: Load current

Schematic	Output configuration	Load	Connection	Wiring diagram
	1a	AC/DC	—	

For further information go to: <http://www.panasonic-electric-works.com>

AMEYA360

Components Supply Platform

Authorized Distribution Brand :



Website :

Welcome to visit www.ameya360.com

Contact Us :

➤ Address :

401 Building No.5, JiuGe Business Center, Lane 2301, Yishan Rd
Minhang District, Shanghai , China

➤ Sales :

Direct +86 (21) 6401-6692

Email amall@ameya360.com

QQ 800077892

Skype [ameyasales1](#) [ameyasales2](#)

➤ Customer Service :

Email service@ameya360.com

➤ Partnership :

Tel +86 (21) 64016692-8333

Email mkt@ameya360.com