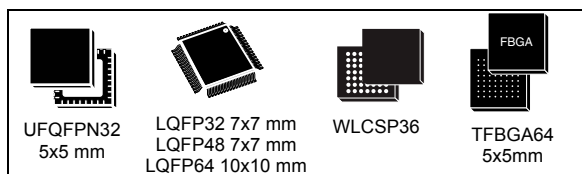


Access line ultra-low-power 32-bit MCU ARM[®]-based Cortex[®]-M0+, up to 64 KB Flash, 8 KB SRAM, 2 KB EEPROM, ADC

Datasheet - production data

Features

- Ultra-low-power platform
 - 1.65 V to 3.6 V power supply
 - -40 to 125 °C temperature range
 - 0.27 µA Standby mode (2 wakeup pins)
 - 0.4 µA Stop mode (16 wakeup lines)
 - 0.8 µA Stop mode + RTC + 8 KB RAM retention
 - 139 µA/MHz Run mode at 32 MHz
 - 3.5 µs wakeup time (from RAM)
 - 5 µs wakeup time (from Flash)
- Core: ARM[®] 32-bit Cortex[®]-M0+ with MPU
 - From 32 kHz up to 32 MHz max.
 - 0.95 DMIPS/MHz
- Reset and supply management
 - Ultra-safe, low-power BOR (brownout reset) with 5 selectable thresholds
 - Ultralow power POR/PDR
 - Programmable voltage detector (PVD)
- Clock sources
 - 1 to 25 MHz crystal oscillator
 - 32 kHz oscillator for RTC with calibration
 - High speed internal 16 MHz factory-trimmed RC (+/- 1%)
 - Internal low-power 37 kHz RC
 - Internal multispeed low-power 65 kHz to 4.2 MHz RC
 - PLL for CPU clock
- Pre-programmed bootloader
 - USART, SPI supported
- Development support
 - Serial wire debug supported
- Up to 51 fast I/Os (45 I/Os 5V tolerant)
- Memories
 - Up to 64 KB Flash with ECC
 - 8KB RAM
 - 2 KB of data EEPROM with ECC
 - 20-byte backup register
 - Sector protection against R/W operation



- Rich Analog peripherals
 - 12-bit ADC 1.14 Msps up to 16 channels (down to 1.65 V)
 - 2x ultra-low-power comparators (window mode and wake up capability, down to 1.8 V)
- 7-channel DMA controller, supporting ADC, SPI, I2C, USART, Timers
- 7x peripherals communication interface
- 2x USART (ISO 7816, IrDA), 1x UART (low power)
- 2x SPI 16 Mbits/s
- 2x I2C (SMBus/PMBus)
- 9x timers: 1x 16-bit with up to 4 channels, 2x 16-bit with up to 2 channels, 1x 16-bit ultra-low-power timer, 1x SysTick, 1x RTC, 1x 16-bit basic, and 2x watchdogs (independent/window)
- CRC calculation unit, 96-bit unique ID
- All packages are ECOPACK^{®2}

Table 1. Device summary

| Reference | Part number |
|-------------|-------------|
| STM32L051x6 | STM32L051C6 |
| | STM32L051K6 |
| | STM32L051R6 |
| | STM32L051T6 |
| STM32L051x8 | STM32L051C8 |
| | STM32L051K8 |
| | STM32L051R8 |
| | STM32L051T8 |

Contents

| | | |
|----------|---|-----------|
| 1 | Introduction | 9 |
| 2 | Description | 10 |
| 2.1 | Device overview | 11 |
| 2.2 | Ultra-low-power device continuum | 13 |
| 3 | Functional overview | 14 |
| 3.1 | Low-power modes | 14 |
| 3.2 | Interconnect matrix | 18 |
| 3.3 | ARM® Cortex®-M0+ core with MPU | 19 |
| 3.4 | Reset and supply management | 20 |
| 3.4.1 | Power supply schemes | 20 |
| 3.4.2 | Power supply supervisor | 20 |
| 3.4.3 | Voltage regulator | 21 |
| 3.4.4 | Boot modes | 21 |
| 3.5 | Clock management | 22 |
| 3.6 | Low-power real-time clock and backup registers | 24 |
| 3.7 | General-purpose inputs/outputs (GPIOs) | 24 |
| 3.8 | Memories | 25 |
| 3.9 | Direct memory access (DMA) | 25 |
| 3.10 | Analog-to-digital converter (ADC) | 25 |
| 3.11 | Temperature sensor | 26 |
| 3.11.1 | Internal voltage reference (V_{REFINT}) | 26 |
| 3.12 | Ultra-low-power comparators and reference voltage | 27 |
| 3.13 | System configuration controller | 27 |
| 3.14 | Timers and watchdogs | 28 |
| 3.14.1 | General-purpose timers (TIM2, TIM21 and TIM22) | 28 |
| 3.14.2 | Low-power Timer (LPTIM) | 29 |
| 3.14.3 | Basic timer (TIM6) | 29 |
| 3.14.4 | SysTick timer | 29 |
| 3.14.5 | Independent watchdog (IWDG) | 29 |
| 3.14.6 | Window watchdog (WWDG) | 29 |

| | | |
|----------|---|-----------|
| 3.15 | Communication interfaces | 30 |
| 3.15.1 | I2C bus | 30 |
| 3.15.2 | Universal synchronous/asynchronous receiver transmitter (USART) | 31 |
| 3.15.3 | Low-power universal asynchronous receiver transmitter (LPUART) | 31 |
| 3.15.4 | Serial peripheral interface (SPI)/Inter-integrated sound (I2S) | 32 |
| 3.16 | Cyclic redundancy check (CRC) calculation unit | 32 |
| 3.17 | Serial wire debug port (SW-DP) | 32 |
| 4 | Pin descriptions | 33 |
| 5 | Memory mapping | 45 |
| 6 | Electrical characteristics | 46 |
| 6.1 | Parameter conditions | 46 |
| 6.1.1 | Minimum and maximum values | 46 |
| 6.1.2 | Typical values | 46 |
| 6.1.3 | Typical curves | 46 |
| 6.1.4 | Loading capacitor | 46 |
| 6.1.5 | Pin input voltage | 46 |
| 6.1.6 | Power supply scheme | 47 |
| 6.1.7 | Current consumption measurement | 47 |
| 6.2 | Absolute maximum ratings | 48 |
| 6.3 | Operating conditions | 50 |
| 6.3.1 | General operating conditions | 50 |
| 6.3.2 | Embedded reset and power control block characteristics | 51 |
| 6.3.3 | Embedded internal reference voltage | 53 |
| 6.3.4 | Supply current characteristics | 54 |
| 6.3.5 | Wakeup time from low-power mode | 64 |
| 6.3.6 | External clock source characteristics | 65 |
| 6.3.7 | Internal clock source characteristics | 70 |
| 6.3.8 | PLL characteristics | 72 |
| 6.3.9 | Memory characteristics | 73 |
| 6.3.10 | EMC characteristics | 75 |
| 6.3.11 | Electrical sensitivity characteristics | 76 |
| 6.3.12 | I/O current injection characteristics | 77 |
| 6.3.13 | I/O port characteristics | 78 |
| 6.3.14 | NRST pin characteristics | 82 |

| | | |
|----------|--|------------|
| 6.3.15 | 12-bit ADC characteristics | 83 |
| 6.3.16 | Temperature sensor characteristics | 88 |
| 6.3.17 | Comparators | 88 |
| 6.3.18 | Timer characteristics | 89 |
| 6.3.19 | Communications interfaces | 91 |
| 7 | Package characteristics | 98 |
| 7.1 | Package mechanical data | 98 |
| 7.1.1 | LQFP32 7 x 7 mm low profile quad flat package | 98 |
| 7.1.2 | UFQFPN32 5 x 5 mm package | 101 |
| 7.1.3 | LQFP48 7 x 7 mm low profile quad flat package | 104 |
| 7.1.4 | LQFP64 10 x 10 mm low profile quad flat package | 107 |
| 7.1.5 | WLCSP36 0.4 mm pitch wafer-level chip scale package | 110 |
| 7.1.6 | TFBGA64 5 x 5 mm thin profile fine pitch ball grid array package | 111 |
| 7.2 | Thermal characteristics | 113 |
| 7.2.1 | Reference document | 114 |
| 8 | Ordering information | 115 |
| 9 | Revision history | 116 |

List of tables

| | | |
|-----------|---|----|
| Table 1. | Device summary | 1 |
| Table 2. | Ultra-low-power STM32L051x6/x8 device features and peripheral counts. | 11 |
| Table 3. | Functionalities depending on the operating power supply range | 16 |
| Table 4. | CPU frequency range depending on dynamic voltage scaling | 16 |
| Table 5. | Functionalities depending on the working mode (from Run/active down to standby) | 16 |
| Table 6. | STM32L0xx peripherals interconnect matrix | 19 |
| Table 7. | Temperature sensor calibration values. | 26 |
| Table 8. | Internal voltage reference measured values. | 27 |
| Table 9. | Timer feature comparison. | 28 |
| Table 10. | Comparison of I2C analog and digital filters. | 30 |
| Table 11. | STM32L051x6/8 I ² C implementation | 30 |
| Table 12. | USART implementation | 31 |
| Table 13. | SPI/I2S implementation | 32 |
| Table 14. | Legend/abbreviations used in the pinout table | 36 |
| Table 15. | STM32L051x6/8 pin definitions | 37 |
| Table 16. | Alternate function port A | 42 |
| Table 17. | Alternate function port B | 43 |
| Table 18. | Alternate function port C | 44 |
| Table 19. | Alternate function port D | 44 |
| Table 20. | Voltage characteristics | 48 |
| Table 21. | Current characteristics | 49 |
| Table 22. | Thermal characteristics. | 49 |
| Table 23. | General operating conditions | 50 |
| Table 24. | Embedded reset and power control block characteristics. | 51 |
| Table 25. | Embedded internal reference voltage calibration values | 53 |
| Table 26. | Embedded internal reference voltage. | 53 |
| Table 27. | Current consumption in Run mode, code with data processing running from Flash. | 55 |
| Table 28. | Current consumption in Run mode vs code type, code with data processing running from Flash | 55 |
| Table 29. | Current consumption in Run mode, code with data processing running from RAM | 57 |
| Table 30. | Current consumption in Run mode vs code type, code with data processing running from RAM | 57 |
| Table 31. | Current consumption in Sleep mode | 58 |
| Table 32. | Current consumption in Low-power Run mode | 59 |
| Table 33. | Current consumption in Low-power Sleep mode | 60 |
| Table 34. | Typical and maximum current consumptions in Stop mode | 61 |
| Table 35. | Typical and maximum current consumptions in Standby mode | 62 |
| Table 36. | Average current consumption during wakeup | 62 |
| Table 37. | Peripheral current consumption in run or Sleep mode | 63 |
| Table 38. | Peripheral current consumption in Stop and Standby mode | 64 |
| Table 39. | Low-power mode wakeup timings | 65 |
| Table 40. | High-speed external user clock characteristics. | 66 |
| Table 41. | Low-speed external user clock characteristics | 67 |
| Table 42. | HSE oscillator characteristics | 68 |
| Table 43. | LSE oscillator characteristics | 69 |
| Table 44. | 16 MHz HSI16 oscillator characteristics | 70 |
| Table 45. | LSI oscillator characteristics | 71 |

| | | |
|-----------|---|-----|
| Table 46. | MSI oscillator characteristics | 71 |
| Table 47. | PLL characteristics | 72 |
| Table 48. | RAM and hardware registers | 73 |
| Table 49. | Flash memory and data EEPROM characteristics | 74 |
| Table 50. | Flash memory and data EEPROM endurance and retention | 74 |
| Table 51. | EMS characteristics | 75 |
| Table 52. | EMI characteristics | 76 |
| Table 53. | ESD absolute maximum ratings | 76 |
| Table 54. | Electrical sensitivities | 77 |
| Table 55. | I/O current injection susceptibility | 77 |
| Table 56. | I/O static characteristics | 78 |
| Table 57. | Output voltage characteristics | 80 |
| Table 58. | I/O AC characteristics | 81 |
| Table 59. | NRST pin characteristics | 82 |
| Table 60. | ADC characteristics | 83 |
| Table 61. | R_{AIN} max for $f_{ADC} = 14$ MHz | 85 |
| Table 62. | ADC accuracy | 85 |
| Table 63. | Temperature sensor calibration values | 88 |
| Table 64. | Temperature sensor characteristics | 88 |
| Table 65. | Comparator 1 characteristics | 88 |
| Table 66. | Comparator 2 characteristics | 89 |
| Table 67. | TIMx characteristics | 90 |
| Table 68. | I2C analog filter characteristics | 91 |
| Table 69. | SPI characteristics in voltage Range 1 | 92 |
| Table 70. | SPI characteristics in voltage Range 2 | 93 |
| Table 71. | SPI characteristics in voltage Range 3 | 94 |
| Table 72. | I2S characteristics | 96 |
| Table 73. | LQFP32, 7 x 7 mm, 32-pin low-profile quad flat package mechanical data | 99 |
| Table 74. | UFQFPN32, 5 x 5 mm, 32-pin package mechanical data | 102 |
| Table 75. | LQFP48, 7 x 7 mm, 48-pin low-profile quad flat package mechanical data | 105 |
| Table 76. | LQFP64, 10 x 10 mm 64-pin low-profile quad flat package mechanical data | 108 |
| Table 77. | WLCSP36 0.4 mm pitch wafer-level chip scale package mechanical data | 110 |
| Table 78. | TFBGA64, 5 x 5 mm, 64-bump thin profile fine pitch ball grid array package mechanical data | 112 |
| Table 79. | Thermal characteristics | 113 |
| Table 80. | STM32L051x6/8 ordering information scheme | 115 |
| Table 81. | Document revision history | 116 |

List of figures

| | | |
|------------|---|-----|
| Figure 1. | STM32L051x6/8 block diagram | 12 |
| Figure 2. | Clock tree | 23 |
| Figure 3. | STM32L051x6/8 WLCSP36 ballout | 33 |
| Figure 4. | STM32L051x6/8 LQFP32 pinout | 33 |
| Figure 5. | STM32L051x6/8 UFQFPN32 pinout | 34 |
| Figure 6. | STM32L051x6/8 LQFP48 pinout - 7 x 7 mm | 34 |
| Figure 7. | STM32L051x6/8 LQFP64 pinout - 10 x 10 mm | 35 |
| Figure 8. | STM32L051x6/8 TFBGA64 ballout - 5x 5 mm | 36 |
| Figure 9. | Memory map | 45 |
| Figure 10. | Pin loading conditions | 46 |
| Figure 11. | Pin input voltage | 46 |
| Figure 12. | Power supply scheme | 47 |
| Figure 13. | Current consumption measurement scheme | 47 |
| Figure 14. | IDD vs VDD, at TA= 25/55/85/105 °C, Run mode, code running from Flash memory, Range 2, HSE, 1WS | 56 |
| Figure 15. | IDD vs VDD, at TA= 25/55/85/105 °C, Run mode, code running from Flash memory, Range 2, HSI16, 1WS | 56 |
| Figure 16. | IDD vs VDD, at TA= 25/55/ 85/105/125 °C, Low-power run mode, code running from RAM, Range 3, MSI (Range 0) at 64 KHz, 0 WS | 60 |
| Figure 17. | IDD vs VDD, at TA= 25/55/ 85/105/125 °C, Stop mode with RTC enabled and running on LSE Low drive | 61 |
| Figure 18. | IDD vs VDD, at TA= 25/55/85/105/125 °C, Stop mode with RTC disabled, all clocks off | 61 |
| Figure 19. | High-speed external clock source AC timing diagram | 66 |
| Figure 20. | Low-speed external clock source AC timing diagram | 67 |
| Figure 21. | HSE oscillator circuit diagram | 68 |
| Figure 22. | Typical application with a 32.768 kHz crystal | 69 |
| Figure 23. | HSI16 minimum and maximum value versus temperature | 70 |
| Figure 24. | VIH/VIL versus VDD (CMOS I/Os) | 79 |
| Figure 25. | VIH/VIL versus VDD (TTL I/Os) | 79 |
| Figure 26. | I/O AC characteristics definition | 82 |
| Figure 27. | Recommended NRST pin protection | 83 |
| Figure 28. | ADC accuracy characteristics | 86 |
| Figure 29. | Typical connection diagram using the ADC | 86 |
| Figure 30. | Power supply and reference decoupling (V_{REF+} not connected to V_{DDA}) | 87 |
| Figure 31. | Power supply and reference decoupling (V_{REF+} connected to V_{DDA}) | 87 |
| Figure 32. | SPI timing diagram - slave mode and CPHA = 0 | 94 |
| Figure 33. | SPI timing diagram - slave mode and CPHA = 1 ⁽¹⁾ | 95 |
| Figure 34. | SPI timing diagram - master mode ⁽¹⁾ | 95 |
| Figure 35. | I ² S slave timing diagram (Philips protocol) ⁽¹⁾ | 97 |
| Figure 36. | I ² S master timing diagram (Philips protocol) ⁽¹⁾ | 97 |
| Figure 37. | LQFP32, 7 x 7 mm, 32-pin low-profile quad flat package outline | 98 |
| Figure 38. | LQFP32 recommended footprint | 99 |
| Figure 39. | LQFP32 marking (package top view) | 100 |
| Figure 40. | UFQFPN32, 5 x 5 mm, 32-pin package outline | 101 |
| Figure 41. | UFQFPN32 recommended footprint | 102 |
| Figure 42. | UFQFPN32 marking (package top view) | 103 |
| Figure 43. | LQFP48, 7 x 7 mm, 48-pin low-profile quad flat package outline | 104 |

| | | |
|------------|--|-----|
| Figure 44. | LQFP48 recommended footprint | 106 |
| Figure 45. | LQFP48 marking (package top view) | 106 |
| Figure 46. | LQFP64, 10 x 10 mm, 64-pin low-profile quad flat package outline | 107 |
| Figure 47. | LQFP64 recommended footprint | 108 |
| Figure 48. | LQFP64 marking (package top view) | 109 |
| Figure 49. | WLCSP36 0.4 mm pitch wafer-level chip scale package outline | 110 |
| Figure 50. | TFBGA64, 5 x 5 mm, 64-bump thin profile fine pitch ball grid array package outline. | 111 |
| Figure 51. | TFBGA64 marking (package top view). | 112 |
| Figure 52. | Thermal resistance | 114 |

1 Introduction

The ultra-low-power STM32L051x6/8 are offered in 6 different package types: from 48 pins to 64 pins. Depending on the device chosen, different sets of peripherals are included, the description below gives an overview of the complete range of peripherals proposed in this family.

These features make the ultra-low-power STM32L051x6/8 microcontrollers suitable for a wide range of applications:

- Gas/water meters and industrial sensors
- Healthcare and fitness equipment
- Remote control and user interface
- PC peripherals, gaming, GPS equipment
- Alarm system, wired and wireless sensors, video intercom

This STM32L051x6/8 datasheet should be read in conjunction with the STM32L0x1xx reference manual (RM0377).

For information on the ARM® Cortex®-M0+ core please refer to the Cortex®-M0+ Technical Reference Manual, available from the www.arm.com website.

Figure 1 shows the general block diagram of the device family.

2 Description

The access line ultra-low-power STM32L051x6/8 microcontrollers incorporate the high-performance ARM[®] Cortex[®]-M0+ 32-bit RISC core operating at a 32 MHz frequency, a memory protection unit (MPU), high-speed embedded memories (64 Kbytes of Flash program memory, 2 Kbytes of data EEPROM and 8 Kbytes of RAM) plus an extensive range of enhanced I/Os and peripherals.

The STM32L051x6/8 devices provide high power efficiency for a wide range of performance. It is achieved with a large choice of internal and external clock sources, an internal voltage adaptation and several low-power modes.

The STM32L051x6/8 devices offer several analog features, one 12-bit ADC with hardware oversampling, two ultra-low-power comparators, several timers, one low-power timer (LPTIM), three general-purpose 16-bit timers and one basic timer, one RTC and one SysTick which can be used as timebases. They also feature two watchdogs, one watchdog with independent clock and window capability and one window watchdog based on bus clock.

Moreover, the STM32L051x6/8 devices embed standard and advanced communication interfaces: up to two I2Cs, two SPIs, one I2S, two USARTs, a low-power UART (LPUART), .

The STM32L051x6/8 also include a real-time clock and a set of backup registers that remain powered in Standby mode.

The ultra-low-power STM32L051x6/8 devices operate from a 1.8 to 3.6 V power supply (down to 1.65 V at power down) with BOR and from a 1.65 to 3.6 V power supply without BOR option. They are available in the -40 to +125 °C temperature range. A comprehensive set of power-saving modes allows the design of low-power applications.



2.1 Device overview

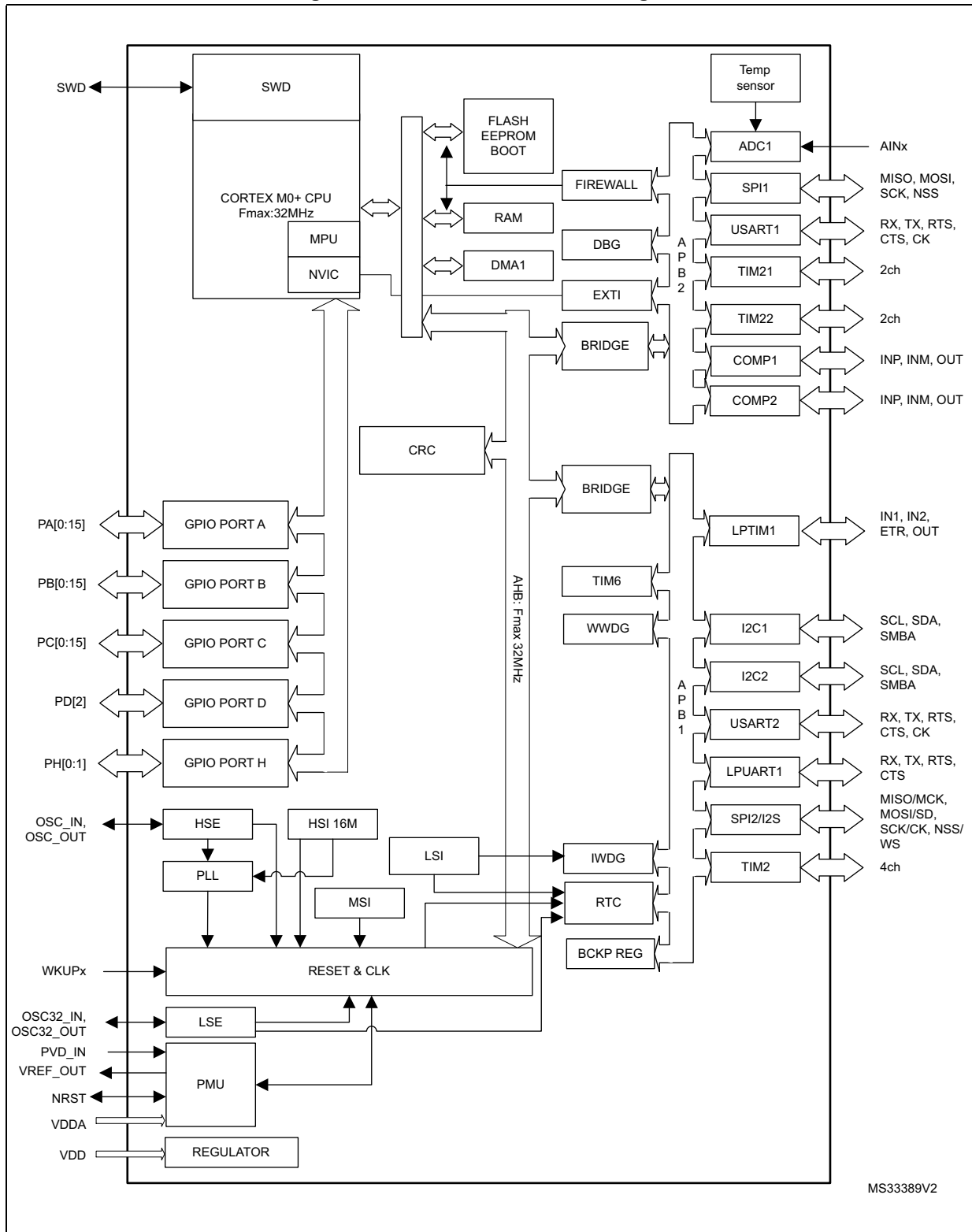
Table 2. Ultra-low-power STM32L051x6/x8 device features and peripheral counts

| Peripheral | | STM32 L051K6 | STM32 L051T6 | STM32 L051C6 | STM32 L051R6 | STM32 L051K8 | STM32 L051T8 | STM32 L051C8 | STM32 L051R8 |
|---|------------------|---|--------------|--------------|------------------------|-------------------------|--------------|--------------|------------------------|
| Flash (Kbytes) | | 32 | | | | 64 | | | |
| Data EEPROM (Kbytes) | | 2 | | | | 2 | | | |
| RAM (Kbytes) | | 8 | | | | 8 | | | |
| Timers | General-purpose | 3 | | | | 3 | | | |
| | Basic | 1 | | | | 1 | | | |
| | LPTIMER | 1 | | | | 1 | | | |
| RTC/SYSTICK/IWDG/WWDG | | 1/1/1/1 | | | | 1/1/1/1 | | | |
| Communication interfaces | SPI/(I2S) | 1/(0) | 1/(0) | 2/(1) | 2/(1) | 1/(0) | 1/(1) | 2/(1) | 2/(1) |
| | I ² C | 1 | 2 | 2 | 2 | 1 | 2 | 2 | 2 |
| | USART | 2 | | | | 2 | | | |
| | LPUART | 0 | 1 | 1 | 1 | 0 | 1 | 1 | 1 |
| GPIOs | | 27 ⁽¹⁾ | 29 | 37 | 51 ⁽²⁾ | 27 ⁽¹⁾ | 29 | 37 | 51 ⁽²⁾ |
| Clocks: HSE/LSE/HSI/MSI/LSI | | 0/1/1/1/1 | 1/1/1/1/1 | 1/1/1/1/1 | 1/1/1/1/1 | 0/1/1/1/1 | 1/1/1/1/1 | 1/1/1/1/1 | 1/1/1/1/1 |
| 12-bit synchronized ADC Number of channels | | 1 10 | 1 10 | 1 10 | 1 16 ⁽²⁾ | 1 10 | 1 10 | 1 10 | 1 16 ⁽²⁾ |
| Comparators | | 2 | | | | 2 | | | |
| Max. CPU frequency | | 32 MHz | | | | | | | |
| Operating voltage | | 1.8 V to 3.6 V (down to 1.65 V at power-down) with BOR option 1.65 V to 3.6 V without BOR option | | | | | | | |
| Operating temperatures | | Ambient temperature: -40 to +125 °C Junction temperature: -40 to +130 °C | | | | | | | |
| Packages | | LQFP32, UFQFPN 32 | WLCS P36 | LQFP48 | LQFP64 TFBGA 64 | LQFP32, UFQFPN 32 | WLCS P36 | LQFP48 | LQFP64 TFBGA 64 |

1. LQFP32 has two GPIOs, less than UFQFPN32 (27).

2. TFBGA64 has one GPIO, one ADC input and one capacitive sensing channel less than LQFP64.

Figure 1. STM32L051x6/8 block diagram



MS33389V2

2.2 Ultra-low-power device continuum

The ultra-low-power family offers a large choice of core and features, from proprietary 8-bit core to up ARM® Cortex®-M3, including ARM® Cortex®-M0+. The STM32Lx series are the best choice to answer your needs in terms of ultra-low-power features. The STM32 Ultra-low-power series are the best solution for applications such as gaz/water meter, keyboard/mouse or fitness and healthcare application. Several built-in features like LCD drivers, dual-bank memory, low-power Run mode, operational amplifiers, AES 128-bit, DAC, crystal-less USB and many other definitely help you building a highly cost optimized application by reducing BOM cost. STMicroelectronics, as a reliable and long-term manufacturer, ensures as much as possible pin-to-pin compatibility between all STM8Lx and STM32Lx on one hand, and between all STM32Lx and STM32Fx on the other hand. Thanks to this unprecedented scalability, your legacy application can be upgraded to respond to the latest market feature and efficiency requirements.

3 Functional overview

3.1 Low-power modes

The ultra-low-power STM32L051x6/8 support dynamic voltage scaling to optimize its power consumption in Run mode. The voltage from the internal low-drop regulator that supplies the logic can be adjusted according to the system's maximum operating frequency and the external voltage supply.

There are three power consumption ranges:

- Range 1 (V_{DD} range limited to 1.71-3.6 V), with the CPU running at up to 32 MHz
- Range 2 (full V_{DD} range), with a maximum CPU frequency of 16 MHz
- Range 3 (full V_{DD} range), with a maximum CPU frequency limited to 4.2 MHz

Seven low-power modes are provided to achieve the best compromise between low-power consumption, short startup time and available wakeup sources:

- **Sleep mode**

In Sleep mode, only the CPU is stopped. All peripherals continue to operate and can wake up the CPU when an interrupt/event occurs. Sleep mode power consumption at 16 MHz is about 1 mA with all peripherals off.

- **Low-power run mode**

This mode is achieved with the multispeed internal (MSI) RC oscillator set to the low-speed clock (max 131 kHz), execution from SRAM or Flash memory, and internal regulator in low-power mode to minimize the regulator's operating current. In Low-power run mode, the clock frequency and the number of enabled peripherals are both limited.

- **Low-power sleep mode**

This mode is achieved by entering Sleep mode with the internal voltage regulator in low-power mode to minimize the regulator's operating current. In Low-power sleep mode, both the clock frequency and the number of enabled peripherals are limited; a typical example would be to have a timer running at 32 kHz.

When wakeup is triggered by an event or an interrupt, the system reverts to the Run mode with the regulator on.

- **Stop mode with RTC**

The Stop mode achieves the lowest power consumption while retaining the RAM and register contents and real time clock. All clocks in the V_{CORE} domain are stopped, the PLL, MSI RC, HSE crystal and HSI RC oscillators are disabled. The LSE or LSI is still running. The voltage regulator is in the low-power mode.

Some peripherals featuring wakeup capability can enable the HSI RC during Stop mode to detect their wakeup condition.

The device can be woken up from Stop mode by any of the EXTI line, in 3.5 μ s, the processor can serve the interrupt or resume the code. The EXTI line source can be any GPIO. It can be the PVD output, the comparator 1 event or comparator 2 event

(if internal reference voltage is on), it can be the RTC alarm/tamper/timestamp/wakeup events, the USART/I2C/LPUART/LPTIMER wakeup events.

- **Stop mode without RTC**

The Stop mode achieves the lowest power consumption while retaining the RAM and register contents. All clocks are stopped, the PLL, MSI RC, HSI and LSI RC, HSE and LSE crystal oscillators are disabled.

Some peripherals featuring wakeup capability can enable the HSI RC during Stop mode to detect their wakeup condition.

The voltage regulator is in the low-power mode. The device can be woken up from Stop mode by any of the EXTI line, in 3.5 μ s, the processor can serve the interrupt or resume the code. The EXTI line source can be any GPIO. It can be the PVD output, the comparator 1 event or comparator 2 event (if internal reference voltage is on). It can also be wakened by the USART/I2C/LPUART/LPTIMER wakeup events.

- **Standby mode with RTC**

The Standby mode is used to achieve the lowest power consumption and real time clock. The internal voltage regulator is switched off so that the entire V_{CORE} domain is powered off. The PLL, MSI RC, HSE crystal and HSI RC oscillators are also switched off. The LSE or LSI is still running. After entering Standby mode, the RAM and register contents are lost except for registers in the Standby circuitry (wakeup logic, IWDG, RTC, LSI, LSE Crystal 32 KHz oscillator, RCC_CSR register).

The device exits Standby mode in 60 μ s when an external reset (NRST pin), an IWDG reset, a rising edge on one of the three WKUP pins, RTC alarm (Alarm A or Alarm B), RTC tamper event, RTC timestamp event or RTC Wakeup event occurs.

- **Standby mode without RTC**

The Standby mode is used to achieve the lowest power consumption. The internal voltage regulator is switched off so that the entire V_{CORE} domain is powered off. The PLL, MSI RC, HSI and LSI RC, HSE and LSE crystal oscillators are also switched off. After entering Standby mode, the RAM and register contents are lost except for registers in the Standby circuitry (wakeup logic, IWDG, RTC, LSI, LSE Crystal 32 KHz oscillator, RCC_CSR register).

The device exits Standby mode in 60 μ s when an external reset (NRST pin) or a rising edge on one of the three WKUP pin occurs.

Note: The RTC, the IWDG, and the corresponding clock sources are not stopped automatically by entering Stop or Standby mode.

Table 3. Functionalities depending on the operating power supply range

| Operating power supply range | Functionalities depending on the operating power supply range | | |
|---|---|-------------------------------|----------------------------|
| | ADC operation | Dynamic voltage scaling range | I/O operation |
| $V_{DD} = 1.65$ to 1.71 V | ADC only, conversion time up to 570 Msps | Range 2 or range 3 | Degraded speed performance |
| $V_{DD} = 1.71$ to 1.8 V ⁽¹⁾ | ADC only, conversion time up to 1.14 Msps | Range 1, range 2 or range 3 | Degraded speed performance |
| $V_{DD} = 1.8$ to 2.0 V ⁽¹⁾ | Conversion time up to 1.14 Msps | Range 1, range 2 or range 3 | Degraded speed performance |
| $V_{DD} = 2.0$ to 2.4 V | Conversion time up to 1.14 Msps | Range 1, range 2 or range 3 | Full speed operation |
| $V_{DD} = 2.4$ to 3.6 V | Conversion time up to 1.14 Msps | Range 1, range 2 or range 3 | Full speed operation |

1. CPU frequency changes from initial to final must respect "fcpu initial <4*fcpu final". It must also respect 5 μs delay between two changes. For example to switch from 4.2 MHz to 32 MHz, you can switch from 4.2 MHz to 16 MHz, wait 5 μs, then switch from 16 MHz to 32 MHz.

Table 4. CPU frequency range depending on dynamic voltage scaling

| CPU frequency range | Dynamic voltage scaling range |
|--|-------------------------------|
| 16 MHz to 32 MHz (1ws) 32 kHz to 16 MHz (0ws) | Range 1 |
| 8 MHz to 16 MHz (1ws) 32 kHz to 8 MHz (0ws) | Range 2 |
| 32 kHz to 4.2 MHz (0ws) | Range 3 |

Table 5. Functionalities depending on the working mode (from Run/active down to standby) ⁽¹⁾

| IPs | Run/Active | Sleep | Low-power run | Low-power sleep | Stop | | Standby | |
|------------------|------------|-------|---------------|-----------------|-------------------|-------------------|---------|----|
| | | | | | Wakeup capability | Wakeup capability | | |
| CPU | Y | -- | Y | -- | -- | -- | -- | -- |
| Flash memory | O | O | O | O | -- | -- | -- | -- |
| RAM | Y | Y | Y | Y | Y | -- | -- | -- |
| Backup registers | Y | Y | Y | Y | Y | Y | Y | Y |

Table 5. Functionalities depending on the working mode (from Run/active down to standby)⁽¹⁾

| IPs | Run/Active | Sleep | Low-power run | Low-power sleep | Stop | | Standby | |
|-------------------------------------|------------|-------|---------------|-----------------|-------------------|-------------------|---------|---|
| | | | | | Wakeup capability | Wakeup capability | | |
| EEPROM | O | O | O | O | -- | | -- | |
| Brown-out reset (BOR) | O | O | O | O | O | O | O | O |
| DMA | O | O | O | O | -- | | -- | |
| Programmable Voltage Detector (PVD) | O | O | O | O | O | O | - | |
| Power-on/down reset (POR/PDR) | Y | Y | Y | Y | Y | Y | Y | Y |
| High Speed Internal (HSI) | O | O | -- | -- | (2) | | -- | |
| High Speed External (HSE) | O | O | O | O | -- | | -- | |
| Low Speed Internal (LSI) | O | O | O | O | O | | O | |
| Low Speed External (LSE) | O | O | O | O | O | | O | |
| Multi-Speed Internal (MSI) | O | O | Y | Y | -- | | -- | |
| Inter-Connect Controller | Y | Y | Y | Y | Y | | -- | |
| RTC | O | O | O | O | O | O | O | |
| RTC Tamper | O | O | O | O | O | O | O | O |
| Auto WakeUp (AWU) | O | O | O | O | O | O | O | O |
| USART | O | O | O | O | O ⁽³⁾ | O | -- | |
| LPUART | O | O | O | O | O ⁽³⁾ | O | -- | |
| SPI | O | O | O | O | -- | | -- | |
| I2C | O | O | O | O | O ⁽⁴⁾ | O | -- | |
| ADC | O | O | O | O | -- | | -- | |
| Temperature sensor | O | O | O | O | O | | -- | |
| Comparators | O | O | O | O | O | O | -- | |
| 16-bit timers | O | O | O | O | -- | | -- | |
| LPTIMER | O | O | O | O | O | O | | |
| IWDG | O | O | O | O | O | O | O | O |

Table 5. Functionalities depending on the working mode (from Run/active down to standby)⁽¹⁾

| IPs | Run/Active | Sleep | Low-power run | Low-power sleep | Stop | | Standby | |
|---|---------------------------------------|--------------------------------------|-----------------|-------------------|--|-------------------|---|--------|
| | | | | | Wakeup capability | Wakeup capability | | |
| WWDG | O | O | O | O | -- | | -- | |
| SysTick Timer | O | O | O | O | | | -- | |
| GPIOs | O | O | O | O | O | O | | 2 pins |
| Wakeup time to Run mode | 0 μs | 0.36 μs | 3 μs | 32 μs | 3.5 μs | | 50 μs | |
| Consumption V _{DD} =1.8 to 3.6 V (Typ) | Down to 140 μA/MHz (from Flash) | Down to 37 μA/MHz (from Flash) | Down to 8 μA | Down to 4.5 μA | 0.4 μA (No RTC) V _{DD} =1.8 V | | 0.28 μA (No RTC) V _{DD} =1.8 V | |
| | | | | | 0.8 μA (with RTC) V _{DD} =1.8 V | | 0.65 μA (with RTC) V _{DD} =1.8 V | |
| | | | | | 0.4 μA (No RTC) V _{DD} =3.0 V | | 0.29 μA (No RTC) V _{DD} =3.0 V | |
| | | | | | 1 μA (with RTC) V _{DD} =3.0 V | | 0.85 μA (with RTC) V _{DD} =3.0 V | |

- Legend:
 "Y" = Yes (enable).
 "O" = Optional can be enabled/disabled by software
 "-" = Not available
- Some peripherals with wakeup from Stop capability can request HSI to be enabled. In this case, HSI is woken up by the peripheral, and only feeds the peripheral which requested it. HSI is automatically put off when the peripheral does not need it anymore.
- UART and LPUART reception is functional in Stop mode. It generates a wakeup interrupt on Start. To generate a wakeup on address match or received frame event, the LPUART can run on LSE clock while the UART has to wake up or keep running the HSI clock.
- I2C address detection is functional in Stop mode. It generates a wakeup interrupt in case of address match. It will wake up the HSI during reception.

3.2 Interconnect matrix

Several peripherals are directly interconnected. This allows autonomous communication between peripherals, thus saving CPU resources and power consumption. In addition, these hardware connections allow fast and predictable latency.

Depending on peripherals, these interconnections can operate in Run, Sleep, Low-power run, Low-power sleep and Stop modes.

Table 6. STM32L0xx peripherals interconnect matrix

| Interconnect source | Interconnect destination | Interconnect action | Run | Sleep | Low-power run | Low-power sleep | Stop |
|---------------------|--------------------------|--|-----|-------|---------------|-----------------|------|
| COMPx | TIM2,TIM21, TIM22 | Timer input channel, trigger from analog signals comparison | Y | Y | Y | Y | - |
| | LPTIM | Timer input channel, trigger from analog signals comparison | Y | Y | Y | Y | Y |
| TIMx | TIMx | Timer triggered by other timer | Y | Y | Y | Y | - |
| RTC | TIM21 | Timer triggered by Auto wake-up | Y | Y | Y | Y | - |
| | LPTIM | Timer triggered by RTC event | Y | Y | Y | Y | Y |
| All clock source | TIMx | Clock source used as input channel for RC measurement and trimming | Y | Y | Y | Y | - |
| GPIO | TIMx | Timer input channel and trigger | Y | Y | Y | Y | - |
| | LPTIM | Timer input channel and trigger | Y | Y | Y | Y | Y |
| | ADC | Conversion trigger | Y | Y | Y | Y | - |

3.3 ARM® Cortex®-M0+ core with MPU

The Cortex-M0+ processor is an entry-level 32-bit ARM Cortex processor designed for a broad range of embedded applications. It offers significant benefits to developers, including:

- a simple architecture that is easy to learn and program
- ultra-low power, energy-efficient operation
- excellent code density
- deterministic, high-performance interrupt handling
- upward compatibility with Cortex-M processor family
- platform security robustness, with integrated Memory Protection Unit (MPU).

The Cortex-M0+ processor is built on a highly area and power optimized 32-bit processor core, with a 2-stage pipeline von Neumann architecture. The processor delivers exceptional energy efficiency through a small but powerful instruction set and extensively optimized design, providing high-end processing hardware including a single-cycle multiplier.

The Cortex-M0+ processor provides the exceptional performance expected of a modern 32-bit architecture, with a higher code density than other 8-bit and 16-bit microcontrollers.

Owing to its embedded ARM core, the STM32L051x6/8 are compatible with all ARM tools and software.

Nested vectored interrupt controller (NVIC)

The ultra-low-power STM32L051x6/8 embed a nested vectored interrupt controller able to handle up to 32 maskable interrupt channels and 4 priority levels.

The Cortex-M0+ processor closely integrates a configurable Nested Vectored Interrupt Controller (NVIC), to deliver industry-leading interrupt performance. The NVIC:

- includes a Non-Maskable Interrupt (NMI)
- provides zero jitter interrupt option
- provides four interrupt priority levels

The tight integration of the processor core and NVIC provides fast execution of Interrupt Service Routines (ISRs), dramatically reducing the interrupt latency. This is achieved through the hardware stacking of registers, and the ability to abandon and restart load-multiple and store-multiple operations. Interrupt handlers do not require any assembler wrapper code, removing any code overhead from the ISRs. Tail-chaining optimization also significantly reduces the overhead when switching from one ISR to another.

To optimize low-power designs, the NVIC integrates with the sleep modes, that include a deep sleep function that enables the entire device to enter rapidly stop or standby mode.

This hardware block provides flexible interrupt management features with minimal interrupt latency.

3.4 Reset and supply management

3.4.1 Power supply schemes

- $V_{DD} = 1.65$ to 3.6 V: external power supply for I/Os and the internal regulator. Provided externally through V_{DD} pins.
- V_{SSA} , $V_{DDA} = 1.65$ to 3.6 V: external analog power supplies for ADC reset blocks, RCs and PLL. V_{DDA} and V_{SSA} must be connected to V_{DD} and V_{SS} , respectively.

3.4.2 Power supply supervisor

The devices have an integrated ZEROPOWER power-on reset (POR)/power-down reset (PDR) that can be coupled with a brownout reset (BOR) circuitry.

Two versions are available:

- The version with BOR activated at power-on operates between 1.8 V and 3.6 V.
- The other version without BOR operates between 1.65 V and 3.6 V.

After the V_{DD} threshold is reached (1.65 V or 1.8 V depending on the BOR which is active or not at power-on), the option byte loading process starts, either to confirm or modify default thresholds, or to disable the BOR permanently: in this case, the V_{DD} min value becomes 1.65 V (whatever the version, BOR active or not, at power-on).

When BOR is active at power-on, it ensures proper operation starting from 1.8 V whatever the power ramp-up phase before it reaches 1.8 V. When BOR is not active at power-up, the power ramp-up should guarantee that 1.65 V is reached on V_{DD} at least 1 ms after it exits the POR area.

Five BOR thresholds are available through option bytes, starting from 1.8 V to 3 V. To reduce the power consumption in Stop mode, it is possible to automatically switch off the internal reference voltage (V_{REFINT}) in Stop mode. The device remains in reset mode when V_{DD} is below a specified threshold, $V_{POR/PDR}$ or V_{BOR} , without the need for any external reset circuit.

Note: The start-up time at power-on is typically 3.3 ms when BOR is active at power-up, the start-up time at power-on can be decreased down to 1 ms typically for devices with BOR inactive at power-up.

The devices feature an embedded programmable voltage detector (PVD) that monitors the V_{DD}/V_{DDA} power supply and compares it to the V_{PVD} threshold. This PVD offers 7 different levels between 1.85 V and 3.05 V, chosen by software, with a step around 200 mV. An interrupt can be generated when V_{DD}/V_{DDA} drops below the V_{PVD} threshold and/or when V_{DD}/V_{DDA} is higher than the V_{PVD} threshold. The interrupt service routine can then generate a warning message and/or put the MCU into a safe state. The PVD is enabled by software.

3.4.3 Voltage regulator

The regulator has three operation modes: main (MR), low power (LPR) and power down.

- MR is used in Run mode (nominal regulation)
- LPR is used in the Low-power run, Low-power sleep and Stop modes
- Power down is used in Standby mode. The regulator output is high impedance, the kernel circuitry is powered down, inducing zero consumption but the contents of the registers and RAM are lost except for the standby circuitry (wake-up logic, IWDG, RTC, LSI, LSE crystal 32 KHz oscillator, RCC_CSR).

3.4.4 Boot modes

At startup, BOOT0 pin and BOOT1 option bit are used to select one of three boot options:

- Boot from Flash memory
- Boot from System memory
- Boot from embedded RAM

The boot loader is located in System memory. It is used to reprogram the Flash memory by using USART1 (PA9, PA10), SPI1 (PA4, PA5, PA6, PA7) or SPI2 (PB12, PB13, PB14, PB15) and USART2 (PA2, PA3). See STM32™ microcontroller system memory boot mode AN2606 for details.

3.5 Clock management

The clock controller distributes the clocks coming from different oscillators to the core and the peripherals. It also manages clock gating for low-power modes and ensures clock robustness. It features:

- **Clock prescaler**

To get the best trade-off between speed and current consumption, the clock frequency to the CPU and peripherals can be adjusted by a programmable prescaler.
- **Safe clock switching**

Clock sources can be changed safely on the fly in Run mode through a configuration register.
- **Clock management**

To reduce power consumption, the clock controller can stop the clock to the core, individual peripherals or memory.
- **System clock source**

Three different clock sources can be used to drive the master clock SYSCLK:

 - 1-24 MHz high-speed external crystal (HSE), that can supply a PLL
 - 16 MHz high-speed internal RC oscillator (HSI), trimmable by software, that can supply a PLL
 - Multispeed internal RC oscillator (MSI), trimmable by software, able to generate 7 frequencies (65 kHz, 131 kHz, 262 kHz, 524 kHz, 1.05 MHz, 2.1 MHz, 4.2 MHz). When a 32.768 kHz clock source is available in the system (LSE), the MSI frequency can be trimmed by software down to a $\pm 0.5\%$ accuracy.
- **Auxiliary clock source**

Two ultra-low-power clock sources that can be used to drive the real-time clock:

 - 32.768 kHz low-speed external crystal (LSE)
 - 37 kHz low-speed internal RC (LSI), also used to drive the independent watchdog. The LSI clock can be measured using the high-speed internal RC oscillator for greater precision.
- **RTC clock source**

The LSI, LSE or HSE sources can be chosen to clock the RTC, whatever the system clock.
- **Startup clock**

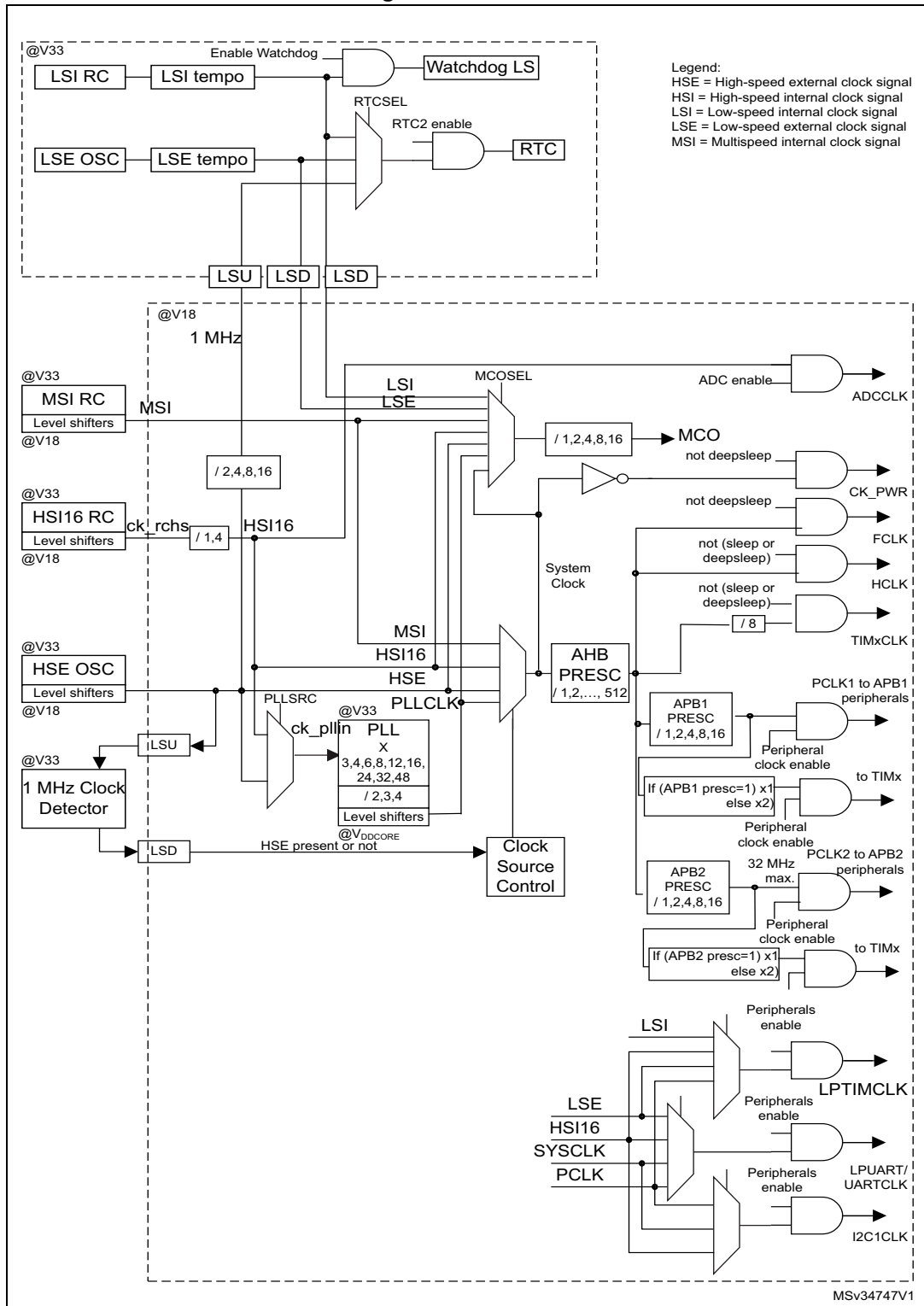
After reset, the microcontroller restarts by default with an internal 2 MHz clock (MSI). The prescaler ratio and clock source can be changed by the application program as soon as the code execution starts.
- **Clock security system (CSS)**

This feature can be enabled by software. If an HSE clock failure occurs, the master clock is automatically switched to HSI and a software interrupt is generated if enabled. Another clock security system can be enabled, in case of failure of the LSE it provides an interrupt or wakeup event which is generated if enabled.
- **Clock-out capability (MCO: microcontroller clock output)**

It outputs one of the internal clocks for external use by the application.

Several prescalers allow the configuration of the AHB frequency, each APB (APB1 and APB2) domains. The maximum frequency of the AHB and the APB domains is 32 MHz. See [Figure 2](#) for details on the clock tree.

Figure 2. Clock tree



3.6 Low-power real-time clock and backup registers

The real time clock (RTC) and the 5 backup registers are supplied in all modes including standby mode. The backup registers are five 32-bit registers used to store 20 bytes of user application data. They are not reset by a system reset, or when the device wakes up from Standby mode.

The RTC is an independent BCD timer/counter. Its main features are the following:

- Calendar with subsecond, seconds, minutes, hours (12 or 24 format), week day, date, month, year, in BCD (binary-coded decimal) format
- Automatically correction for 28, 29 (leap year), 30, and 31 day of the month
- Two programmable alarms with wake up from Stop and Standby mode capability
- Periodic wakeup from Stop and Standby with programmable resolution and period
- On-the-fly correction from 1 to 32767 RTC clock pulses. This can be used to synchronize it with a master clock.
- Reference clock detection: a more precise second source clock (50 or 60 Hz) can be used to enhance the calendar precision.
- Digital calibration circuit with 1 ppm resolution, to compensate for quartz crystal inaccuracy
- 2 anti-tamper detection pins with programmable filter. The MCU can be woken up from Stop and Standby modes on tamper event detection.
- Timestamp feature which can be used to save the calendar content. This function can be triggered by an event on the timestamp pin, or by a tamper event. The MCU can be woken up from Stop and Standby modes on timestamp event detection.

The RTC clock sources can be:

- A 32.768 kHz external crystal
- A resonator or oscillator
- The internal low-power RC oscillator (typical frequency of 37 kHz)
- The high-speed external clock

3.7 General-purpose inputs/outputs (GPIOs)

Each of the GPIO pins can be configured by software as output (push-pull or open-drain), as input (with or without pull-up or pull-down) or as peripheral alternate function. Most of the GPIO pins are shared with digital or analog alternate functions, and can be individually remapped using dedicated alternate function registers. All GPIOs are high current capable. Each GPIO output, speed can be slowed (40 MHz, 10 MHz, 2 MHz, 400 kHz). The alternate function configuration of I/Os can be locked if needed following a specific sequence in order to avoid spurious writing to the I/O registers. The I/O controller is connected to a dedicated IO bus with a toggling speed of up to 32 MHz.

Extended interrupt/event controller (EXTI)

The extended interrupt/event controller consists of 28 edge detector lines used to generate interrupt/event requests. Each line can be individually configured to select the trigger event (rising edge, falling edge, both) and can be masked independently. A pending register maintains the status of the interrupt requests. The EXTI can detect an external line with a pulse width shorter than the Internal APB2 clock period. Up to 51 GPIOs can be connected to the 16 configurable interrupt/event lines. The 12 other lines are connected to PVD, RTC, USARTs, LPUART, LPTIMER or comparator events.

3.8 Memories

The STM32L051x6/8 devices have the following features:

- 8 Kbytes of embedded SRAM accessed (read/write) at CPU clock speed with 0 wait states. With the enhanced bus matrix, operating the RAM does not lead to any performance penalty during accesses to the system bus (AHB and APB buses).
- The non-volatile memory is divided into three arrays:
 - 32 or 64 Kbytes of embedded Flash program memory
 - 2 Kbytes of data EEPROM
 - Information block containing 32 user and factory options bytes plus 4 Kbytes of system memory

The user options bytes are used to write-protect or read-out protect the memory (with 4 Kbyte granularity) and/or readout-protect the whole memory with the following options:

- **Level 0:** no protection
- **Level 1:** memory readout protected.
The Flash memory cannot be read from or written to if either debug features are connected or boot in RAM is selected
- **Level 2:** chip readout protected, debug features (Cortex-M0+ serial wire) and boot in RAM selection disabled (debugline fuse)

The firewall protects parts of code/data from access by the rest of the code that is executed outside of the protected area. The granularity of the protected code segment or the non-volatile data segment is 256 bytes (Flash or EEPROM) against 64 bytes for the volatile data segment (RAM).

The whole non-volatile memory embeds the error correction code (ECC) feature.

3.9 Direct memory access (DMA)

The flexible 7-channel, general-purpose DMA is able to manage memory-to-memory, peripheral-to-memory and memory-to-peripheral transfers. The DMA controller supports circular buffer management, avoiding the generation of interrupts when the controller reaches the end of the buffer.

Each channel is connected to dedicated hardware DMA requests, with software trigger support for each channel. Configuration is done by software and transfer sizes between source and destination are independent.

The DMA can be used with the main peripherals: SPI, I²C, USART, LPUART, general-purpose timers, and ADC.

3.10 Analog-to-digital converter (ADC)

A native 12-bit, extended to 16-bit through hardware oversampling, analog-to-digital converter is embedded into STM32L051x6/8 device. It has up to 16 external channels and 3 internal channels (temperature sensor, voltage reference). It performs conversions in single-shot or scan mode. In scan mode, automatic conversion is performed on a selected group of analog inputs.

The ADC frequency is independent from the CPU frequency, allowing maximum sampling rate of 1.14 MSPS even with a low CPU speed. The ADC consumption is low at all frequencies (~25 μ A at 10 kSPS, ~200 μ A at 1MSPS). An auto-shutdown function guarantees that the ADC is powered off except during the active conversion phase.

The ADC can be served by the DMA controller. It can operate from a supply voltage down to 1.65 V.

The ADC features a hardware oversampler up to 256 samples, this improves the resolution to 16 bits (see AN2668).

An analog watchdog feature allows very precise monitoring of the converted voltage of one, some or all scanned channels. An interrupt is generated when the converted voltage is outside the programmed thresholds.

The events generated by the general-purpose timers (TIMx) can be internally connected to the ADC start triggers, to allow the application to synchronize A/D conversions and timers.

3.11 Temperature sensor

The temperature sensor (T_{SENSE}) generates a voltage V_{SENSE} that varies linearly with temperature.

The temperature sensor is internally connected to the ADC_IN18 input channel which is used to convert the sensor output voltage into a digital value.

The sensor provides good linearity but it has to be calibrated to obtain good overall accuracy of the temperature measurement. As the offset of the temperature sensor varies from chip to chip due to process variation, the uncalibrated internal temperature sensor is suitable for applications that detect temperature changes only.

To improve the accuracy of the temperature sensor measurement, each device is individually factory-calibrated by ST. The temperature sensor factory calibration data are stored by ST in the system memory area, accessible in read-only mode.

Table 7. Temperature sensor calibration values

| Calibration value name | Description | Memory address |
|------------------------|---|---------------------------|
| TSENSE_CAL1 | TS ADC raw data acquired at temperature of 30 °C, $V_{DDA} = 3$ V | 0x1FF8 007A - 0x1FF8 007B |
| TSENSE_CAL2 | TS ADC raw data acquired at temperature of 130 °C $V_{DDA} = 3$ V | 0x1FF8 007E - 0x1FF8 007F |

3.11.1 Internal voltage reference (V_{REFINT})

The internal voltage reference (V_{REFINT}) provides a stable (bandgap) voltage output for the ADC and Comparators. V_{REFINT} is internally connected to the ADC_IN17 input channel. It enables accurate monitoring of the V_{DD} value (when no external voltage, V_{REF+} , is available for ADC). The precise voltage of V_{REFINT} is individually measured for each part by ST during production test and stored in the system memory area. It is accessible in read-only mode.

Table 8. Internal voltage reference measured values

| Calibration value name | Description | Memory address |
|------------------------|---|---------------------------|
| VREFINT_CAL | Raw data acquired at temperature of 30 °C $V_{DDA} = 3\text{ V}$ | 0x1FF8 0078 - 0x1FF8 0079 |

3.12 Ultra-low-power comparators and reference voltage

The STM32L051x6/8 embed two comparators sharing the same current bias and reference voltage. The reference voltage can be internal or external (coming from an I/O).

- One comparator with ultra low consumption
- One comparator with rail-to-rail inputs, fast or slow mode.
- The threshold can be one of the following:
 - External I/O pins
 - Internal reference voltage (V_{REFINT})
 - submultiple of Internal reference voltage(1/4, 1/2, 3/4) for the rail to rail comparator.

Both comparators can wake up the devices from Stop mode, and be combined into a window comparator.

The internal reference voltage is available externally via a low-power / low-current output buffer (driving current capability of 1 μA typical).

3.13 System configuration controller

The system configuration controller provides the capability to remap some alternate functions on different I/O ports.

The highly flexible routing interface allows the application firmware to control the routing of different I/Os to the TIM2, TIM21, TIM22 and LPTIM timer input captures. It also controls the routing of internal analog signals to ADC, COMP1 and COMP2 and the internal reference voltage V_{REFINT} .

3.14 Timers and watchdogs

The ultra-low-power STM32L051x6/8 devices include three general-purpose timers, one low-power timer (LPTM), one basic timer, two watchdog timers and the SysTick timer.

[Table 9](#) compares the features of the general-purpose and basic timers.

Table 9. Timer feature comparison

| Timer | Counter resolution | Counter type | Prescaler factor | DMA request generation | Capture/compare channels | Complementary outputs |
|--------------|--------------------|-------------------|---------------------------------|------------------------|--------------------------|-----------------------|
| TIM2 | 16-bit | Up, down, up/down | Any integer between 1 and 65536 | Yes | 4 | No |
| TIM21, TIM22 | 16-bit | Up, down, up/down | Any integer between 1 and 65536 | No | 2 | No |
| TIM6 | 16-bit | Up | Any integer between 1 and 65536 | Yes | 0 | No |

3.14.1 General-purpose timers (TIM2, TIM21 and TIM22)

There are three synchronizable general-purpose timers embedded in the STM32L051x6/8 devices (see [Table 9](#) for differences).

TIM2

TIM2 is based on 16-bit auto-reload up/down counter. It includes a 16-bit prescaler. It features four independent channels each for input capture/output compare, PWM or one-pulse mode output.

The TIM2 general-purpose timers can work together or with the TIM21 and TIM22 general-purpose timers via the Timer Link feature for synchronization or event chaining. Their counter can be frozen in debug mode. Any of the general-purpose timers can be used to generate PWM outputs.

TIM2 has independent DMA request generation.

This timer is capable of handling quadrature (incremental) encoder signals and the digital outputs from 1 to 3 hall-effect sensors.

TIM21 and TIM22

TIM21 and TIM22 are based on a 16-bit auto-reload up/down counter. They include a 16-bit prescaler. They have two independent channels for input capture/output compare, PWM or one-pulse mode output. They can work together and be synchronized with the TIM2, full-featured general-purpose timers.

They can also be used as simple time bases and be clocked by the LSE clock source (32.768 kHz) to provide time bases independent from the main CPU clock.

3.14.2 Low-power Timer (LPTIM)

The low-power timer has an independent clock and is running also in Stop mode if it is clocked by LSE, LSI or an external clock. It is able to wakeup the devices from Stop mode.

This low-power timer supports the following features:

- 16-bit up counter with 16-bit autoreload register
- 16-bit compare register
- Configurable output: pulse, PWM
- Continuous / one shot mode
- Selectable software / hardware input trigger
- Selectable clock source
 - Internal clock source: LSE, LSI, HSI or APB clock
 - External clock source over LPTIM input (working even with no internal clock source running, used by the Pulse Counter Application)
- Programmable digital glitch filter
- Encoder mode

3.14.3 Basic timer (TIM6)

This timer can be used as a generic 16-bit timebase.

3.14.4 SysTick timer

This timer is dedicated to the OS, but could also be used as a standard downcounter. It is based on a 24-bit downcounter with autoreload capability and a programmable clock source. It features a maskable system interrupt generation when the counter reaches '0'.

3.14.5 Independent watchdog (IWDG)

The independent watchdog is based on a 12-bit downcounter and 8-bit prescaler. It is clocked from an independent 37 kHz internal RC and, as it operates independently of the main clock, it can operate in Stop and Standby modes. It can be used either as a watchdog to reset the device when a problem occurs, or as a free-running timer for application timeout management. It is hardware- or software-configurable through the option bytes. The counter can be frozen in debug mode.

3.14.6 Window watchdog (WWDG)

The window watchdog is based on a 7-bit downcounter that can be set as free-running. It can be used as a watchdog to reset the device when a problem occurs. It is clocked from the main clock. It has an early warning interrupt capability and the counter can be frozen in debug mode.

3.15 Communication interfaces

3.15.1 I²C bus

Up to two I²C interfaces (I2C1, I2C2) can operate in multimaster or slave modes. All I²C interfaces can support Standard mode (Sm, up to 100 kbit/s), Fast mode (Fm, up to 400 kbit/s) and Fast Mode Plus (Fm+, up to 1 Mbit/s) with 20 mA output drive on some I/Os.

All I²C interfaces support 7-bit and 10-bit addressing modes, multiple 7-bit slave addresses (2 addresses, 1 with configurable mask). They also include programmable analog and digital noise filters.

Table 10. Comparison of I2C analog and digital filters

| | Analog filter | Digital filter |
|----------------------------------|---|--|
| Pulse width of suppressed spikes | ≥ 50 ns | Programmable length from 1 to 15 I2C peripheral clocks |
| Benefits | Available in Stop mode | 1. Extra filtering capability vs. standard requirements. 2. Stable length |
| Drawbacks | Variations depending on temperature, voltage, process | Wakeup from Stop on address match is not available when digital filter is enabled. |

In addition, I2C1 provides hardware support for SMBus 2.0 and PMBus 1.1: ARP capability, Host notify protocol, hardware CRC (PEC) generation/verification, timeouts verifications and ALERT protocol management. I2C1 also has a clock domain independent from the CPU clock, allowing the I2C1 to wake up the MCU from Stop mode on address match.

All I2C interfaces can be served by the DMA controller.

Refer to [Table 11](#) for the differences between I2C interfaces.

Table 11. STM32L051x6/8 I²C implementation

| I2C features ⁽¹⁾ | I2C1 | I2C2 |
|--|------|------------------|
| 7-bit addressing mode | X | X |
| 10-bit addressing mode | X | X |
| Standard mode (up to 100 kbit/s) | X | X |
| Fast mode (up to 400 kbit/s) | X | X |
| Fast Mode Plus with 20 mA output drive I/Os (up to 1 Mbit/s) | X | X ⁽²⁾ |
| Independent clock | X | - |
| SMBus | X | - |
| Wakeup from STOP | X | - |

1. X = supported.

2. See [Table 11](#) for the list of I/Os that feature Fast Mode Plus capability

3.15.2 Universal synchronous/asynchronous receiver transmitter (USART)

The two USART interfaces (USART1, USART2) are able to communicate at speeds of up to 4 Mbit/s.

They provide hardware management of the CTS, RTS and RS485 driver enable (DE) signals, multiprocessor communication mode, master synchronous communication and single-wire half-duplex communication mode. They also support SmartCard communication (ISO 7816), IrDA SIR ENDEC, LIN Master/Slave capability, auto baud rate feature and has a clock domain independent from the CPU clock, allowing to wake up the MCU from Stop mode.

All USART interfaces can be served by the DMA controller.

[Table 12](#) for the supported modes and features of USART interfaces.

Table 12. USART implementation

| USART modes/features ⁽¹⁾ | USART1 and USART2 |
|---|-------------------|
| Hardware flow control for modem | X |
| Continuous communication using DMA | X |
| Multiprocessor communication | X |
| Synchronous mode | X |
| Smartcard mode | X |
| Single-wire half-duplex communication | X |
| IrDA SIR ENDEC block | X |
| LIN mode | X |
| Dual clock domain and wakeup from Stop mode | X |
| Receiver timeout interrupt | X |
| Modbus communication | X |
| Auto baud rate detection (4 modes) | X |
| Driver Enable | X |

1. X = supported.

3.15.3 Low-power universal asynchronous receiver transmitter (LPUART)

The devices embed one Low-power UART. The LPUART supports asynchronous serial communication with minimum power consumption. It supports half duplex single wire communication and modem operations (CTS/RTS). It allows multiprocessor communication.

The LPUART has a clock domain independent from the CPU clock, and can wake up the system from Stop mode. The Wakeup events from Stop mode are programmable and can be:

- Start bit detection
- Or any received data frame
- Or a specific programmed data frame

Only a 32.768 kHz clock (LSE) is needed to allow LPUART communication up to 9600 baud. Therefore, even in Stop mode, the LPUART can wait for an incoming frame while

having an extremely low energy consumption. Higher speed clock can be used to reach higher baudrates.

LPUART interface can be served by the DMA controller.

3.15.4 Serial peripheral interface (SPI)/Inter-integrated sound (I2S)

Up to two SPIs are able to communicate at up to 16 Mbits/s in slave and master modes in full-duplex and half-duplex communication modes. The 3-bit prescaler gives 8 master mode frequencies and the frame is configurable to 8 bits or 16 bits. The hardware CRC generation/verification supports basic SD Card/MMC modes.

One standard I2S interfaces (multiplexed with SPI2) is available. It can operate in master or slave mode, and can be configured to operate with a 16-/32-bit resolution as input or output channels. Audio sampling frequencies from 8 kHz up to 192 kHz are supported. When the I2S interfaces is configured in master mode, the master clock can be output to the external DAC/CODEC at 256 times the sampling frequency.

The SPIs can be served by the DMA controller.

Refer to [Table 13](#) for the differences between SPI1 and SPI2.

Table 13. SPI/I2S implementation

| SPI features ⁽¹⁾ | SPI1 | SPI2 |
|-----------------------------|------|------|
| Hardware CRC calculation | X | X |
| Rx/Tx FIFO | X | X |
| NSS pulse mode | X | X |
| I2S mode | - | X |
| TI mode | X | X |

1. X = supported.

3.16 Cyclic redundancy check (CRC) calculation unit

The CRC (cyclic redundancy check) calculation unit is used to get a CRC code using a configurable generator polynomial value and size.

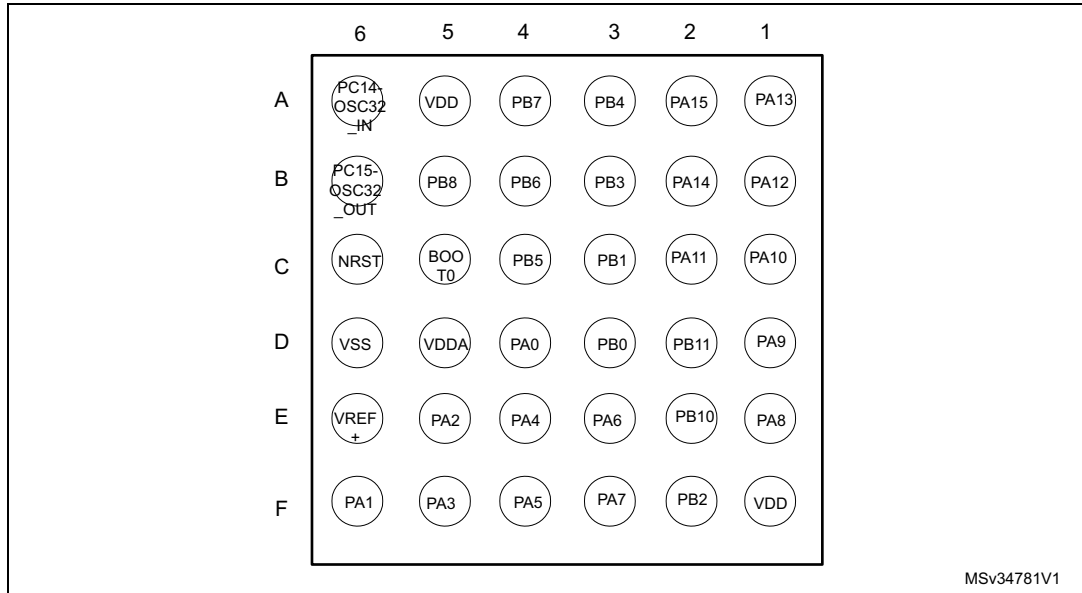
Among other applications, CRC-based techniques are used to verify data transmission or storage integrity. In the scope of the EN/IEC 60335-1 standard, they offer a means of verifying the Flash memory integrity. The CRC calculation unit helps compute a signature of the software during runtime, to be compared with a reference signature generated at linktime and stored at a given memory location.

3.17 Serial wire debug port (SW-DP)

An ARM SW-DP interface is provided to allow a serial wire debugging tool to be connected to the MCU.

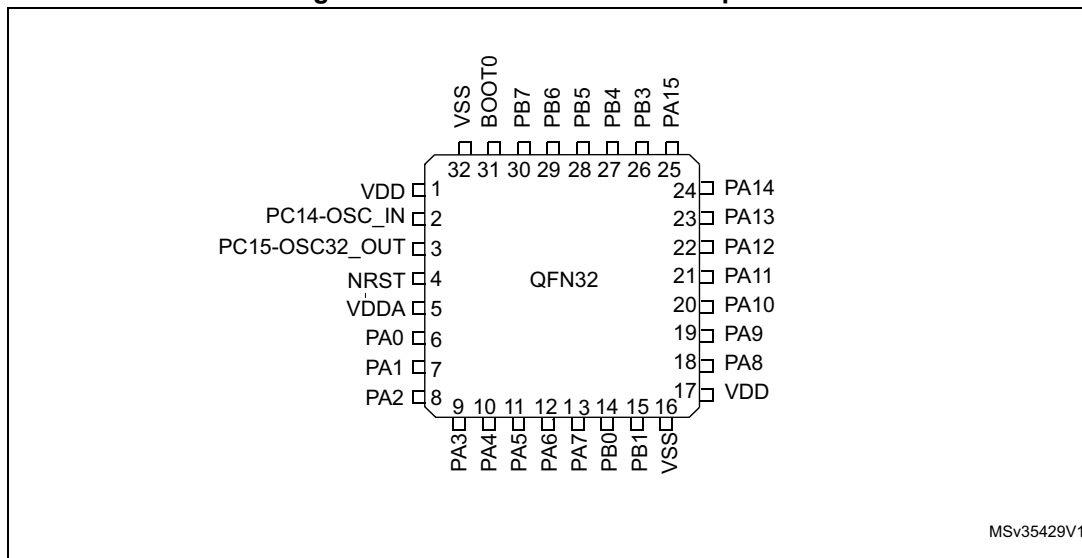
4 Pin descriptions

Figure 3. STM32L051x6/8 WLCSP36 ballout



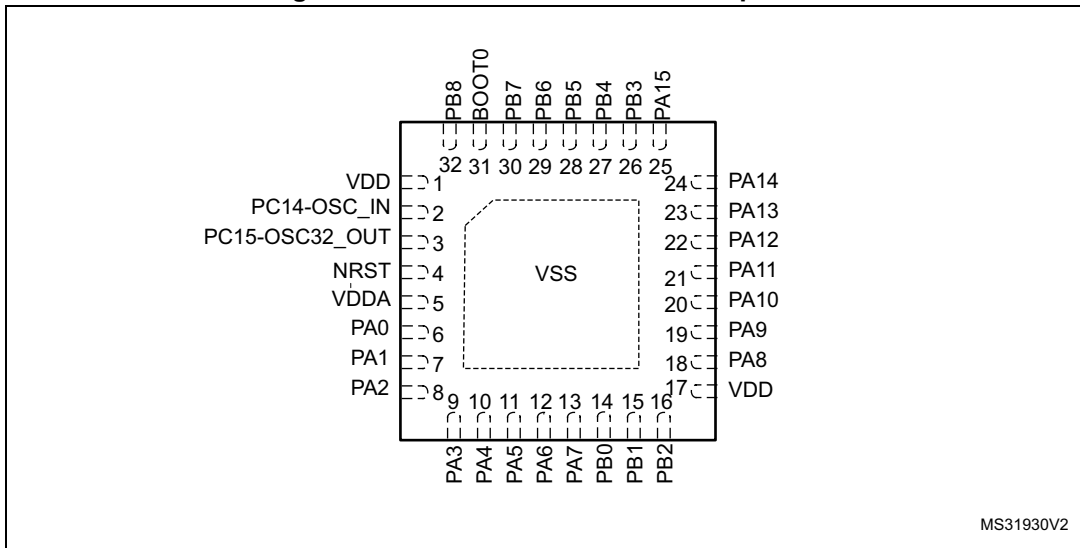
1. The above figure shows the package bump view.

Figure 4. STM32L051x6/8 LQFP32 pinout



1. The above figure shows the package top view.

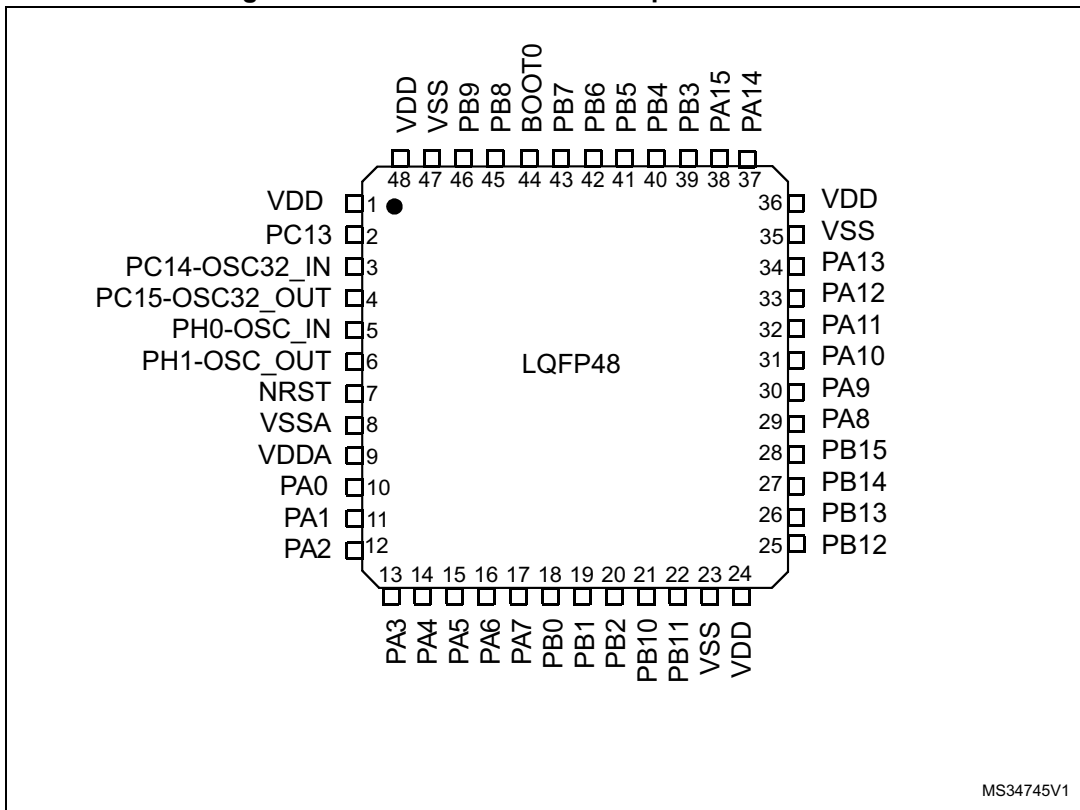
Figure 5. STM32L051x6/8 UFQFPN32 pinout



MS31930V2

1. The above figure shows the package top view.

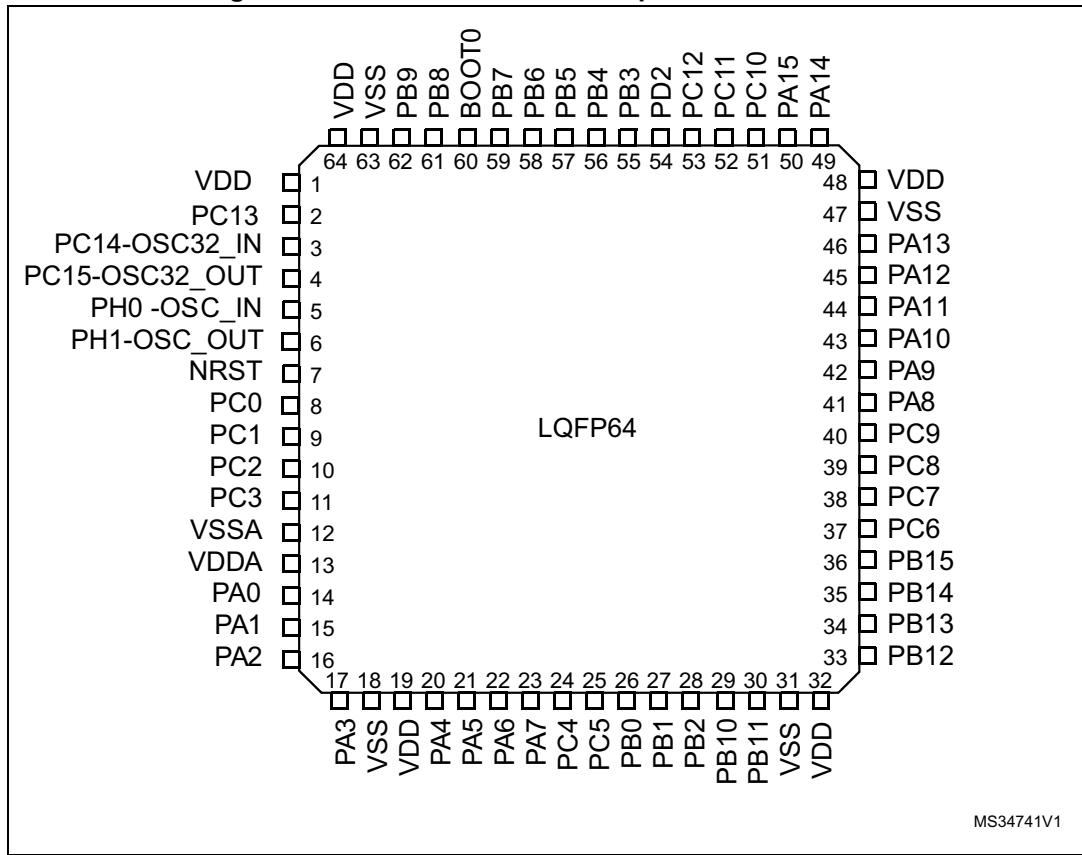
Figure 6. STM32L051x6/8 LQFP48 pinout - 7 x 7 mm



MS34745V1

1. The above figure shows the package top view.

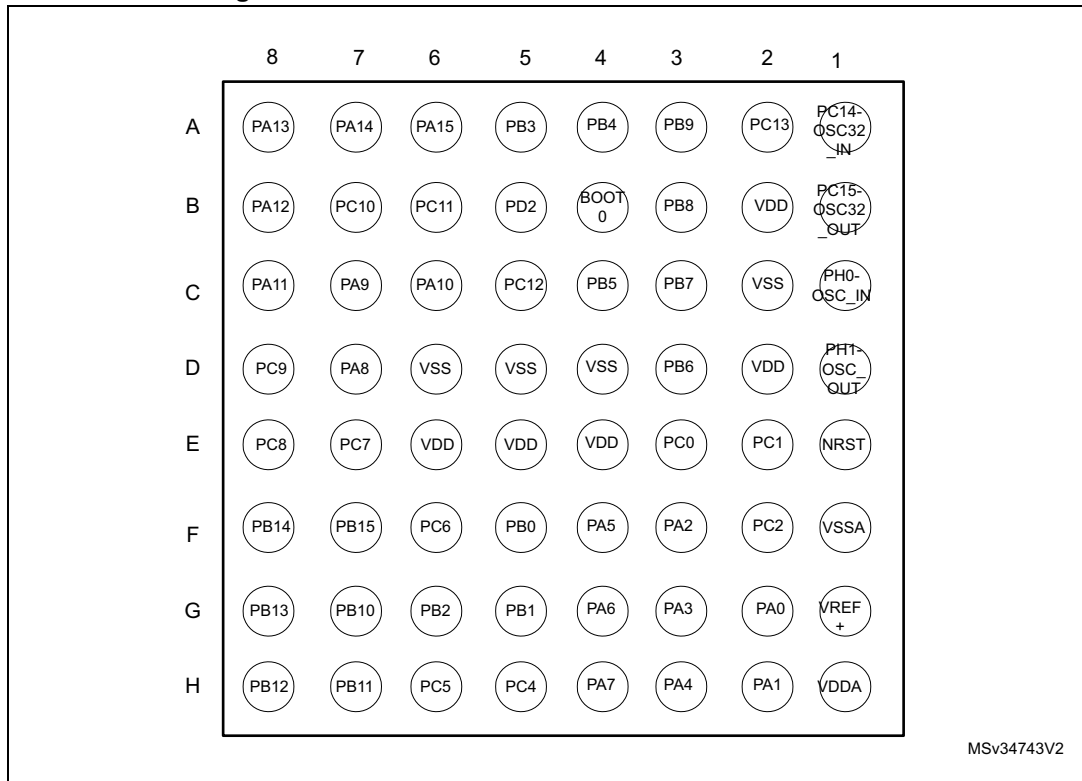
Figure 7. STM32L051x6/8 LQFP64 pinout - 10 x 10 mm



MS34741V1

1. The above figure shows the package top view.

Figure 8. STM32L051x6/8 TFBGA64 ballout - 5x 5 mm



MSv34743V2

1. The above figure shows the package bump view.

Table 14. Legend/abbreviations used in the pinout table

| Name | Abbreviation | Definition |
|---------------|---|--|
| Pin name | Unless otherwise specified in brackets below the pin name, the pin function during and after reset is the same as the actual pin name | |
| Pin type | S | Supply pin |
| | I | Input only pin |
| | I/O | Input / output pin |
| I/O structure | FT | 5 V tolerant I/O |
| | TC | Standard 3.3V I/O |
| | B | Dedicated BOOT0 pin |
| | RST | Bidirectional reset pin with embedded weak pull-up resistor |
| Notes | Unless otherwise specified by a note, all I/Os are set as floating inputs during and after reset. | |
| Pin functions | Alternate functions | Functions selected through GPIOx_AFR registers |
| | Additional functions | Functions directly selected/enabled through peripheral registers |

Table 15. STM32L051x6/8 pin definitions

| Pin Number | | | | | | Pin name (function after reset) | Pin type | I/O structure | Notes | Alternate functions | Additional functions |
|------------|-------------------------|------------------------|--------|--------|---------|---------------------------------------|----------|---------------|-------|--|--|
| LQFP32 | UFQFPN32 ⁽¹⁾ | WLCSP36 ⁽²⁾ | LQFP48 | LQFP64 | TFBGA64 | | | | | | |
| - | - | - | 1 | 1 | B2 | VDD | S | | | | |
| - | - | - | 2 | 2 | A2 | PC13- ANTI_TAMP | I/O | FT | | | RTC_TAMP1/ RTC_TS/ RTC_OUT/ WKUP2 |
| 2 | 2 | A6 | 3 | 3 | A1 | PC14- OSC32_IN | I/O | FT | | | OSC32_IN |
| 3 | 3 | B6 | 4 | 4 | B1 | PC15- OSC32_OUT | I/O | TC | | | OSC32_OUT |
| - | - | - | 5 | 5 | C1 | PH0-OSC_IN | I/O | TC | | | OSC_IN |
| - | - | - | 6 | 6 | D1 | PH1- OSC_OUT | I/O | TC | | | OSC_OUT |
| 4 | 4 | C6 | 7 | 7 | E1 | NRST | I/O | RST | | | |
| - | - | - | - | 8 | E3 | PC0 | I/O | FT | | LPTIM1_IN1, EVENTOUT | ADC_IN10 |
| - | - | - | - | 9 | E2 | PC1 | I/O | FT | | LPTIM1_OUT, EVENTOUT | ADC_IN11 |
| - | - | - | - | 10 | F2 | PC2 | I/O | FT | | LPTIM1_IN2, SPI2_MISO/I2S2_MCK | ADC_IN12 |
| - | - | - | - | 11 | - | PC3 | I/O | FT | | LPTIM1_ETR, SPI2_MOSI/I2S2_SD | ADC_IN13 |
| - | - | - | 8 | 12 | F1 | VSSA | S | | | | |
| - | - | E6 | - | - | G1 | VREF+ | S | | | | |
| 5 | 5 | D5 | 9 | 13 | H1 | VDDA | S | | | | |
| 6 | 6 | D4 | 10 | 14 | G2 | PA0 | I/O | TC | | TIM2_CH1, USART2_CTS, TIM2_ETR, COMP1_OUT | COMP1_INM6, ADC_IN0, RTC_TAMP2/W KUP1 |

Table 15. STM32L051x6/8 pin definitions (continued)

| Pin Number | | | | | | Pin name (function after reset) | Pin type | I/O structure | Notes | Alternate functions | Additional functions |
|------------|-------------------------|------------------------|--------|--------|---------|---------------------------------------|----------|---------------|----------------|--|---------------------------------------|
| LQFP32 | UFQFPN32 ⁽¹⁾ | WLCSP36 ⁽²⁾ | LQFP48 | LQFP64 | TFBGA64 | | | | | | |
| 7 | 7 | F6 | 11 | 15 | H2 | PA1 | I/O | FT | | EVENTOUT, TIM2_CH2, USART2_RTS, TIM21_ETR | COMP1_INP, ADC_IN1 |
| 8 | 8 | E5 | 12 | 16 | F3 | PA2 | I/O | FT | | TIM21_CH1, TIM2_CH3, USART2_TX, COMP2_OUT | COMP2_INM6, ADC_IN2 |
| 9 | 9 | F5 | 13 | 17 | G3 | PA3 | I/O | FT | | TIM21_CH2, TIM2_CH4, USART2_RX | COMP2_INP, ADC_IN3 |
| - | - | - | - | 18 | C2 | VSS | S | | | | |
| - | - | - | - | 19 | D2 | VDD | S | | | | |
| 10 | 10 | E4 | 14 | 20 | H3 | PA4 | I/O | TC | ⁽³⁾ | SPI1_NSS, USART2_CK, TIM22_ETR | COMP1_INM4, COMP2_INM4, ADC_IN4 |
| 11 | 11 | F4 | 15 | 21 | F4 | PA5 | I/O | TC | | SPI1_SCK, TIM2_ETR, TIM2_CH1 | COMP1_INM5, COMP2_INM5, ADC_IN5 |
| 12 | 12 | E3 | 16 | 22 | G4 | PA6 | I/O | FT | | SPI1_MISO, LPUART1_CTS, TIM22_CH1, EVENTOUT, COMP1_OUT | ADC_IN6 |
| 13 | 13 | F3 | 17 | 23 | H4 | PA7 | I/O | FT | | SPI1_MOSI, TIM22_CH2, EVENTOUT, COMP2_OUT | ADC_IN7 |
| - | - | - | - | 24 | H5 | PC4 | I/O | FT | | EVENTOUT, LPUART1_TX | ADC_IN14 |
| - | - | - | - | 25 | H6 | PC5 | I/O | TC | | LPUART1_RX, | ADC_IN15 |
| 14 | 14 | D3 | 18 | 26 | F5 | PB0 | I/O | FT | | EVENTOUT | ADC_IN8, VREF_OUT |
| 15 | 15 | C3 | 19 | 27 | G5 | PB1 | I/O | FT | | LPUART1_RTS | ADC_IN9, VREF_OUT |

Table 15. STM32L051x6/8 pin definitions (continued)

| Pin Number | | | | | | Pin name (function after reset) | Pin type | I/O structure | Notes | Alternate functions | Additional functions |
|------------|-------------------------|------------------------|--------|--------|---------|---------------------------------------|----------|---------------|-------|--|-------------------------|
| LQFP32 | UFQFPN32 ⁽¹⁾ | WLCSP36 ⁽²⁾ | LQFP48 | LQFP64 | TFBGA64 | | | | | | |
| - | 16 | F2 | 20 | 28 | G6 | PB2 | I/O | FT | | LPTIM1_OUT | |
| - | - | E2 | 21 | 29 | G7 | PB10 | I/O | FT | | TIM2_CH3, LPUART1_TX, SPI2_SCK, I2C2_SCL | |
| - | - | D2 | 22 | 30 | H7 | PB11 | I/O | FT | | EVENTOUT, TIM2_CH4, LPUART1_RX, I2C2_SDA | |
| 16 | - | - | 23 | 31 | D6 | VSS | S | | | | |
| 17 | 17 | F1 | 24 | 32 | E6 | VDD | S | | | | |
| - | - | - | 25 | 33 | H8 | PB12 | I/O | FT | | SPI2_NSS/I2S2_WS, LPUART1_RTS, I2C2_SMBA, EVENTOUT | |
| - | - | - | 26 | 34 | G8 | PB13 | I/O | FTf | | SPI2_SCK/I2S2_CK, LPUART1_CTS, I2C2_SCL, TIM21_CH1 | |
| - | - | - | 27 | 35 | F8 | PB14 | I/O | FTf | | SPI2_MISO/I 2S2_MCK, RTC_OUT, LPUART1_RTS, I2C2_SDA, TIM21_CH2 | |
| - | - | - | 28 | 36 | F7 | PB15 | I/O | FT | | SPI2_MOSI/I2S2_SD, RTC_REFIN | |
| - | - | - | - | 37 | F6 | PC6 | I/O | FT | | TIM22_CH1 | |
| - | - | - | - | 38 | E7 | PC7 | I/O | FT | | TIM22_CH2 | |
| - | - | - | - | 39 | E8 | PC8 | I/O | FT | | TIM22_ETR | |
| - | - | - | - | 40 | D8 | PC9 | I/O | FT | | TIM21_ETR | |
| 18 | 18 | E1 | 29 | 41 | D7 | PA8 | I/O | FT | | MCO, EVENTOUT, USART1_CK | |
| 19 | 19 | D1 | 30 | 42 | C7 | PA9 | I/O | FT | | MCO, USART1_TX | |

Table 15. STM32L051x6/8 pin definitions (continued)

| Pin Number | | | | | | Pin name (function after reset) | Pin type | I/O structure | Notes | Alternate functions | Additional functions |
|------------|-------------------------|------------------------|--------|--------|---------|---------------------------------------|----------|---------------|-------|--|-------------------------|
| LQFP32 | UFQFPN32 ⁽¹⁾ | WLCSP36 ⁽²⁾ | LQFP48 | LQFP64 | TFBGA64 | | | | | | |
| 20 | 20 | C1 | 31 | 43 | C6 | PA10 | I/O | FT | | USART1_RX | |
| 21 | 21 | C2 | 32 | 44 | C8 | PA11 | I/O | FT | | SPI1_MISO, EVENTOUT, USART1_CTS, COMP1_OUT | |
| 22 | 22 | B1 | 33 | 45 | B8 | PA12 | I/O | FT | | SPI1_MOSI, EVENTOUT, USART1_RTS, COMP2_OUT | |
| 23 | 23 | A1 | 34 | 46 | A8 | PA13 | I/O | FT | | SWDIO | |
| - | - | - | 35 | 47 | D5 | VSS | S | | | | |
| - | - | - | 36 | 48 | E5 | VDDIO2 | S | | | | |
| 24 | 24 | B2 | 37 | 49 | A7 | PA14 | I/O | FT | | SWCLK, USART2_TX | |
| 25 | 25 | A2 | 38 | 50 | A6 | PA15 | I/O | FT | | SPI1_NSS, TIM2_ETR, EVENTOUT, USART2_RX, TIM2_CH1 | |
| - | - | - | - | 51 | B7 | PC10 | I/O | FT | | LPUART1_TX | |
| - | - | - | - | 52 | B6 | PC11 | I/O | FT | | LPUART1_RX | |
| - | - | - | - | 53 | C5 | PC12 | I/O | FT | | | |
| - | - | - | - | 54 | B5 | PD2 | I/O | FT | | LPUART1_RTS | |
| 26 | 26 | B3 | 39 | 55 | A5 | PB3 | I/O | FT | | SPI1_SCK, TIM2_CH2, EVENTOUT | COMP2_INN |
| 27 | 27 | A3 | 40 | 56 | A4 | PB4 | I/O | FT | | SPI1_MISO, EVENTOUT, TIM22_CH1 | COMP2_INP |
| 28 | 28 | C4 | 41 | 57 | C4 | PB5 | I/O | FT | | SPI1_MOSI, LPTIM1_IN1, I2C1_SMBA, TIM22_CH2 | COMP2_INP |

Table 15. STM32L051x6/8 pin definitions (continued)

| Pin Number | | | | | | Pin name (function after reset) | Pin type | I/O structure | Notes | Alternate functions | Additional functions |
|------------|-------------------------|------------------------|--------|--------|---------|---------------------------------------|----------|---------------|-------|--|-------------------------|
| LQFP32 | UFQFPN32 ⁽¹⁾ | WLCSP36 ⁽²⁾ | LQFP48 | LQFP64 | TFBGA64 | | | | | | |
| 29 | 29 | B4 | 42 | 58 | D3 | PB6 | I/O | FTf | | USART1_TX, I2C1_SCL, LPTIM1_ETR | COMP2_INP |
| 30 | 30 | A4 | 43 | 59 | C3 | PB7 | I/O | FTf | | USART1_RX, I2C1_SDA, LPTIM1_IN2 | COMP2_INP, PVD_IN |
| 31 | 31 | C5 | 44 | 60 | B4 | BOOT0 | B | | | | |
| - | 32 | B5 | 45 | 61 | B3 | PB8 | I/O | FTf | | I2C1_SCL | |
| - | - | - | 46 | 62 | A3 | PB9 | I/O | FTf | | EVENTOUT, I2C1_SDA, SPI2_NSS/I2S2_WS | |
| 32 | - | D6 | 47 | 63 | D4 | VSS | S | | | | |
| 1 | 1 | A5 | 48 | 64 | E4 | VDD | S | | | | |

1. VSS pins are connected to the exposed pad (see [Figure 40: UFQFPN32, 5 x 5 mm, 32-pin package outline](#)).
2. PB9/12/13/14/15, PH0/1 and PC13 GPIOs should be configured as output and driven Low, even if they are not available on this package.
3. PA4 offers a reduced touch sensing sensitivity. It is thus recommended to use it as sampling capacitor I/O.



Table 16. Alternate function port A

| Port | AF0 | AF1 | AF2 | AF3 | AF4 | AF5 | AF6 | AF7 |
|--------|---------------------------------|-----------|--------------------|----------|-------------|------------|----------|-----------|
| | SPI1/TIM21/SYS_A F/EVENTOUT/ | - | TIM2/ EVENTOUT/ | EVENTOUT | USART1/2/3 | TIM2/21/22 | EVENTOUT | COMP1/2 |
| Port A | PA0 | | TIM2_CH1 | | USART2_CTS | TIM2_ETR | | COMP1_OUT |
| | PA1 | EVENTOUT | TIM2_CH2 | | USART2_RTS | TIM21_ETR | | |
| | PA2 | TIM21_CH1 | TIM2_CH3 | | USART2_TX | | | COMP2_OUT |
| | PA3 | TIM21_CH2 | TIM2_CH4 | | USART2_RX | | | |
| | PA4 | SPI1_NSS | | | USART2_CK | TIM22_ETR | | |
| | PA5 | SPI1_SCK | TIM2_ETR | | | TIM2_CH1 | | |
| | PA6 | SPI1_MISO | | | LPUART1_CTS | TIM22_CH1 | EVENTOUT | COMP1_OUT |
| | PA7 | SPI1_MOSI | | | | TIM22_CH2 | EVENTOUT | COMP2_OUT |
| | PA8 | MCO | | | EVENTOUT | USART1_CK | | |
| | PA9 | MCO | | | | USART1_TX | | |
| | PA10 | | | | | USART1_RX | | |
| | PA11 | SPI1_MISO | | EVENTOUT | | USART1_CTS | | COMP1_OUT |
| | PA12 | SPI1_MOSI | | EVENTOUT | | USART1_RTS | | COMP2_OUT |
| | PA13 | SWDIO | | | | | | |
| | PA14 | SWCLK | | | | USART2_TX | | |
| PA15 | SPI1_NSS | | TIM2_ETR | EVENTOUT | USART2_RX | TIM2_CH1 | | |

Table 17. Alternate function port B

| Port | AF0 | AF1 | AF2 | AF3 | AF4 | AF5 | AF6 | |
|--------|---|--------------------|--|-------------|-------------------------------------|----------------|-------------------------|-----------|
| | SPI1/SPI2/I2S2/ USART1/ EVENTOUT/ | I2C1 | LPUART1/LPTIM /TIM2/SYS_AF/ EVENTOUT | I2C1 | I2C1/TIM22/ EVENTOUT/ LPUART1 | SPI2/I2S2/I2C2 | I2C2/TIM21/ EVENTOUT | |
| Port B | PB0 | EVENTOUT | | | | | | |
| | PB1 | | | | LPUART1_RTS | | | |
| | PB2 | | | LPTIM1_OUT | | | | |
| | PB3 | SPI1_SCK | | TIM2_CH2 | | EVENTOUT | | |
| | PB4 | SPI1_MISO | | EVENTOUT | | TIM22_CH1 | | |
| | PB5 | SPI1_MOSI | | LPTIM1_IN1 | I2C1_SMBA | TIM22_CH2 | | |
| | PB6 | USART1_TX | I2C1_SCL | LPTIM1_ETR | | | | |
| | PB7 | USART1_RX | I2C1_SDA | LPTIM1_IN2 | | | | |
| | PB8 | | | | | I2C1_SCL | | |
| | PB9 | | | EVENTOUT | | I2C1_SDA | SPI2_NSS/I2S2_ WS | |
| | PB10 | | | TIM2_CH3 | | LPUART1_TX | SPI2_SCK | I2C2_SCL |
| | PB11 | EVENTOUT | | TIM2_CH4 | | LPUART1_RX | | I2C2_SDA |
| | PB12 | SPI2_NSS/I2S2_WS | | LPUART1_RTS | | | I2C2_SMBA | EVENTOUT |
| | PB13 | SPI2_SCK/I2S2_CK | | | | LPUART1_CTS | I2C2_SCL | TIM21_CH1 |
| | PB14 | SPI2_MISO/I2S2_MCK | | RTC_OUT | | LPUART1_RTS | I2C2_SDA | TIM21_CH2 |
| PB15 | SPI2_MOSI/I2S2_SD | | RTC_REFIN | | | | | |



Table 18. Alternate function port C

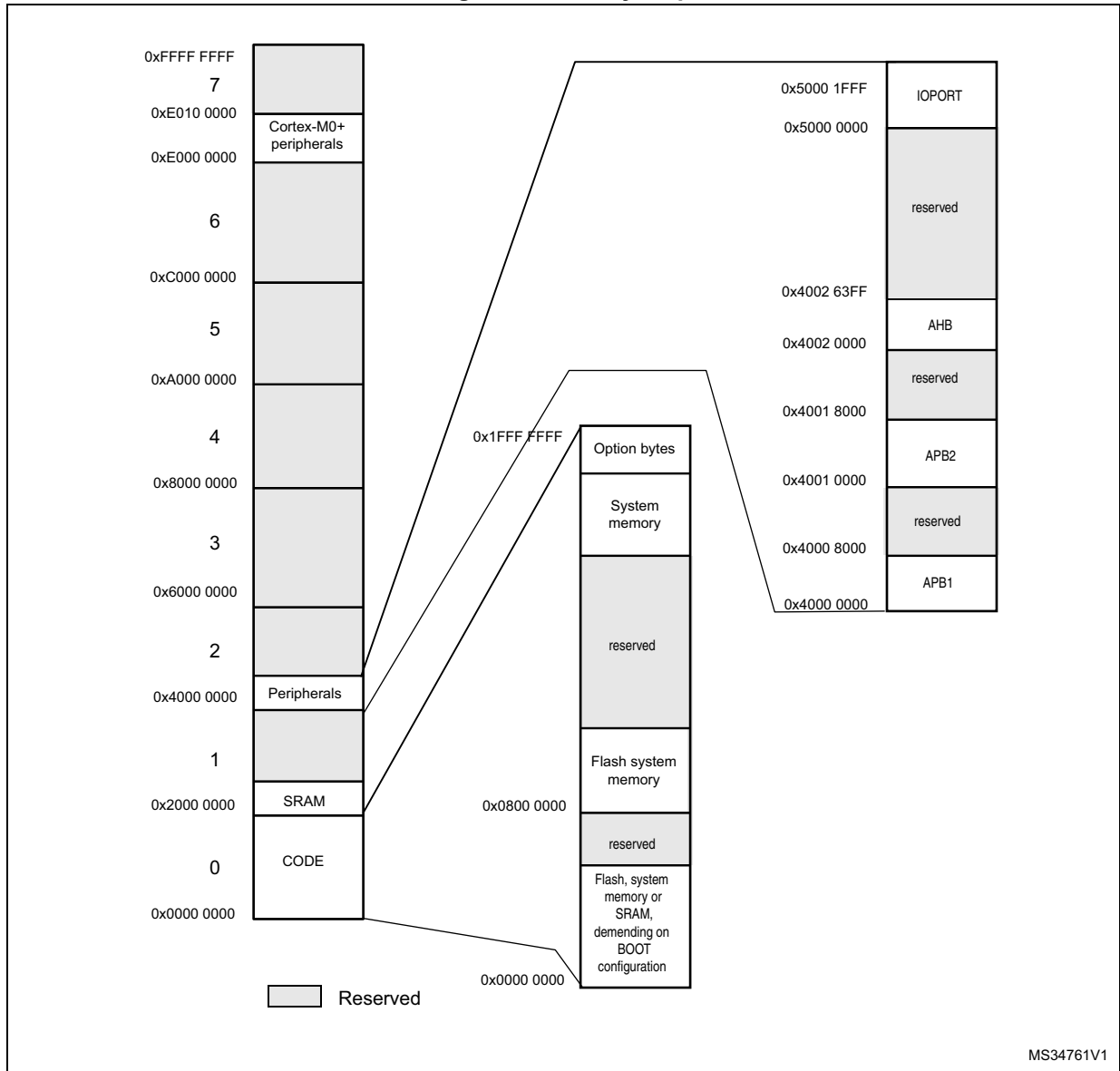
| Port | | AF0 | AF1 | AF2 |
|--------|------|---------------------------------|-----|----------------------------|
| | | LPUART1/LPTIM/TIM21/12/EVENTOUT | - | SPI2/I2S2/LPUART1/EVENTOUT |
| Port C | PC0 | LPTIM1_IN1 | | EVENTOUT |
| | PC1 | LPTIM1_OUT | | EVENTOUT |
| | PC2 | LPTIM1_IN2 | | SPI2_MISO/I2S2_MCK |
| | PC3 | LPTIM1_ETR | | SPI2_MOSI/I2S2_SD |
| | PC4 | EVENTOUT | | LPUART1_TX |
| | PC5 | | | LPUART1_RX |
| | PC6 | TIM22_CH1 | | |
| | PC7 | TIM22_CH2 | | |
| | PC8 | TIM22_ETR | | |
| | PC9 | TIM21_ETR | | |
| | PC10 | LPUART1_TX | | |
| | PC11 | LPUART1_RX | | |
| | PC12 | | | |
| | PC13 | | | |
| | PC14 | | | |
| | PC15 | | | |

Table 19. Alternate function port D

| Port | | AF0 | AF1 |
|--------|-----|-------------|-----|
| | | LPUART1 | - |
| Port D | PD2 | LPUART1_RTS | |

5 Memory mapping

Figure 9. Memory map



6 Electrical characteristics

6.1 Parameter conditions

Unless otherwise specified, all voltages are referenced to V_{SS} .

6.1.1 Minimum and maximum values

Unless otherwise specified the minimum and maximum values are guaranteed in the worst conditions of ambient temperature, supply voltage and frequencies by tests in production on 100% of the devices with an ambient temperature at $T_A = 25\text{ }^\circ\text{C}$ and $T_A = T_{Amax}$ (given by the selected temperature range).

Data based on characterization results, design simulation and/or technology characteristics are indicated in the table footnotes and are not tested in production. Based on characterization, the minimum and maximum values refer to sample tests and represent the mean value plus or minus three times the standard deviation ($\text{mean} \pm 3\sigma$).

6.1.2 Typical values

Unless otherwise specified, typical data are based on $T_A = 25\text{ }^\circ\text{C}$, $V_{DD} = 3.6\text{ V}$ (for the $1.65\text{ V} \leq V_{DD} \leq 3.6\text{ V}$ voltage range). They are given only as design guidelines and are not tested.

Typical ADC accuracy values are determined by characterization of a batch of samples from a standard diffusion lot over the full temperature range, where 95% of the devices have an error less than or equal to the value indicated ($\text{mean} \pm 2\sigma$).

6.1.3 Typical curves

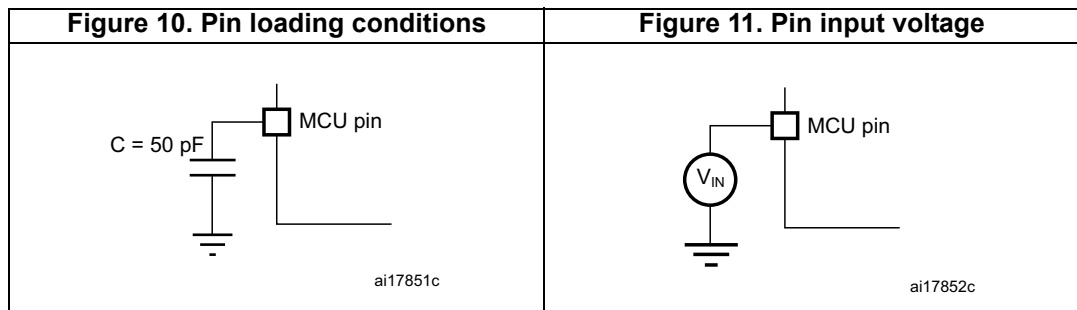
Unless otherwise specified, all typical curves are given only as design guidelines and are not tested.

6.1.4 Loading capacitor

The loading conditions used for pin parameter measurement are shown in [Figure 10](#).

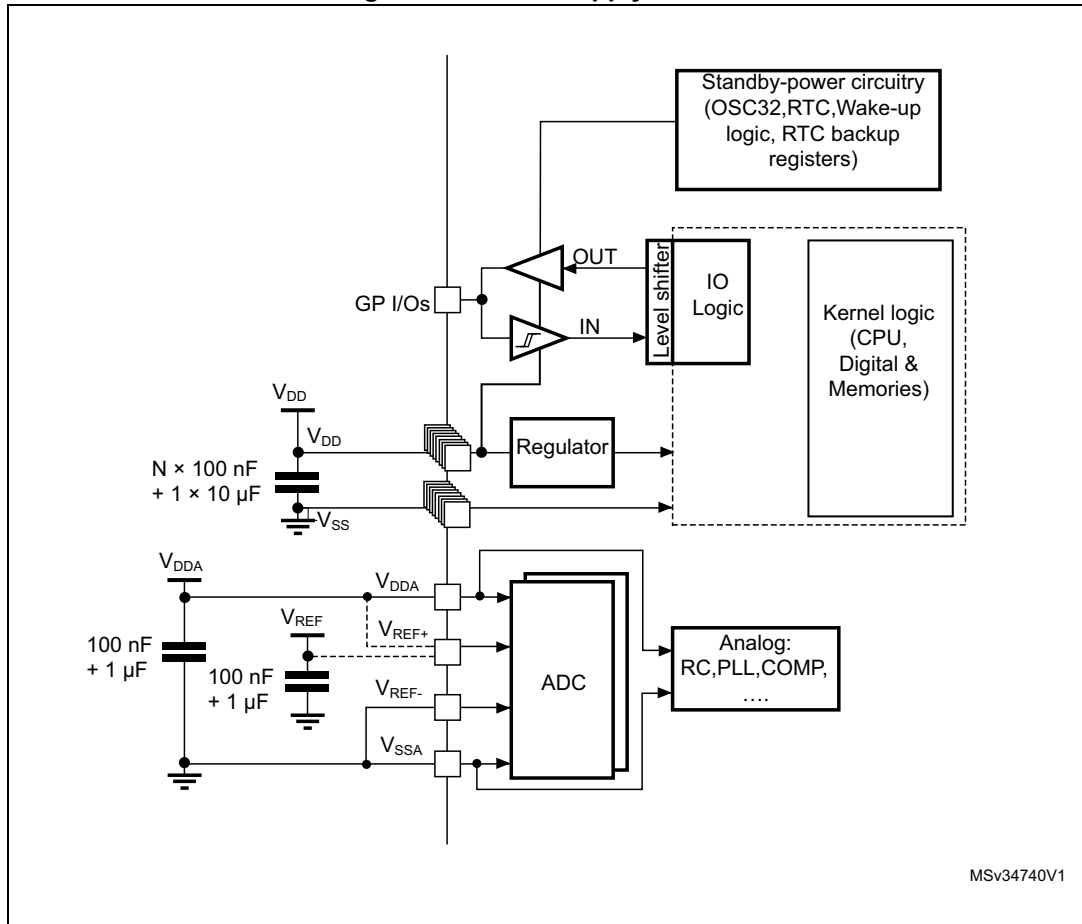
6.1.5 Pin input voltage

The input voltage measurement on a pin of the device is described in [Figure 11](#).



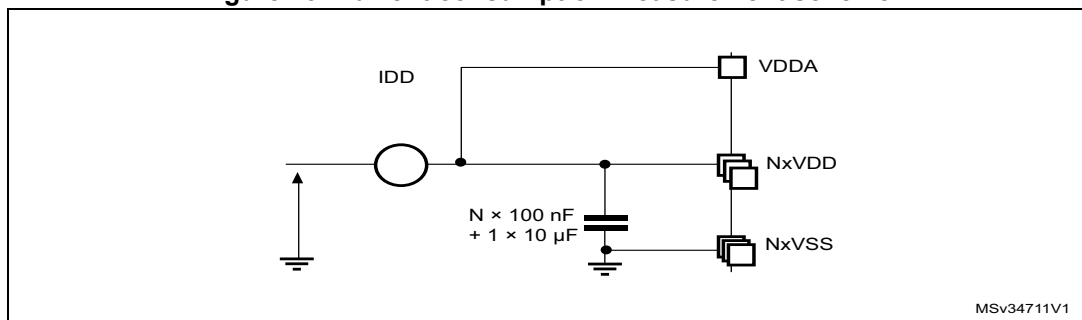
6.1.6 Power supply scheme

Figure 12. Power supply scheme



6.1.7 Current consumption measurement

Figure 13. Current consumption measurement scheme



6.2 Absolute maximum ratings

Stresses above the absolute maximum ratings listed in [Table 20: Voltage characteristics](#), [Table 21: Current characteristics](#), and [Table 22: Thermal characteristics](#) may cause permanent damage to the device. These are stress ratings only and functional operation of the device at these conditions is not implied. Exposure to maximum rating conditions for extended periods may affect device reliability.

Table 20. Voltage characteristics

| Symbol | Ratings | Min | Max | Unit |
|----------------------|---|--|----------------|------|
| $V_{DD}-V_{SS}$ | External main supply voltage (including V_{DDA} , V_{DDIO2} , V_{DD}) ⁽¹⁾ | -0.3 | 4.0 | V |
| $V_{IN}^{(2)}$ | Input voltage on FT and FTf pins | $V_{SS} - 0.3$ | $V_{DD} + 4.0$ | |
| | Input voltage on TC pins | $V_{SS} - 0.3$ | 4.0 | |
| | Input voltage on BOOT0 | V_{SS} | $V_{DD} + 4.0$ | |
| $ \Delta V_{DD} $ | Variations between different V_{DD}/V_{DDA} power pins ⁽³⁾ | - | 50 | mV |
| | $ \Delta V_{SS} $ | Variations between all different ground pins | - | |
| $V_{REF+} - V_{DDA}$ | Allowed voltage difference for $V_{REF+} > V_{DDA}$ | - | 0.4 | V |
| $V_{ESD(HBM)}$ | Electrostatic discharge voltage (human body model) | see Section 6.3.11 | | |

1. All main power (V_{DD} , V_{DDIO2} , V_{DDA}) and ground (V_{SS} , V_{SSA}) pins must always be connected to the external power supply, in the permitted range.
2. V_{IN} maximum must always be respected. Refer to [Table 21](#) for maximum allowed injected current values.
3. It is recommended to power V_{DD} and V_{DDA} from the same source. A maximum difference of 300 mV between V_{DD} and V_{DDA} can be tolerated during power-up and device operation. V_{DDIO2} is independent from V_{DD} and V_{DDA} : its value does not need to respect this rule.

Table 21. Current characteristics

| Symbol | Ratings | Max. | Unit |
|------------------------|--|------------------------|------|
| $\Sigma I_{VDD}^{(2)}$ | Total current into sum of all V_{DD} power lines (source) ⁽¹⁾ | 105 | mA |
| $\Sigma I_{VSS}^{(2)}$ | Total current out of sum of all V_{SS} ground lines (sink) ⁽¹⁾ | 105 | |
| $I_{VDD(PIN)}$ | Maximum current into each V_{DD} power pin (source) ⁽¹⁾ | 100 | |
| $I_{VSS(PIN)}$ | Maximum current out of each V_{SS} ground pin (sink) ⁽¹⁾ | 100 | |
| I_{IO} | Output current sunk by any I/O and control pin except FTf pins | 16 | |
| | Output current sunk by FTf pins | 22 | |
| | Output current sourced by any I/O and control pin | -16 | |
| $\Sigma I_{IO(PIN)}$ | Total output current sunk by sum of all IOs and control pins ⁽²⁾ | 90 | |
| | Total output current sourced by sum of all IOs and control pins ⁽²⁾ | -90 | |
| $I_{INJ(PIN)}$ | Injected current on FT, FFf, RST and B pins | -5/+0 ⁽³⁾ | |
| | Injected current on TC pin | ± 5 ⁽⁴⁾ | |
| $\Sigma I_{INJ(PIN)}$ | Total injected current (sum of all I/O and control pins) ⁽⁵⁾ | ± 25 | |

1. All main power (V_{DD} , V_{DDA}) and ground (V_{SS} , V_{SSA}) pins must always be connected to the external power supply, in the permitted range.
2. This current consumption must be correctly distributed over all I/Os and control pins. The total output current must not be sunk/sourced between two consecutive power supply pins referring to high pin count LQFP packages.
3. Positive current injection is not possible on these I/Os. A negative injection is induced by $V_{IN} < V_{SS}$. $I_{INJ(PIN)}$ must never be exceeded. Refer to [Table 20](#) for maximum allowed input voltage values.
4. A positive injection is induced by $V_{IN} > V_{DD}$ while a negative injection is induced by $V_{IN} < V_{SS}$. $I_{INJ(PIN)}$ must never be exceeded. Refer to [Table 20: Voltage characteristics](#) for the maximum allowed input voltage values.
5. When several inputs are submitted to a current injection, the maximum $\Sigma I_{INJ(PIN)}$ is the absolute sum of the positive and negative injected currents (instantaneous values).

Table 22. Thermal characteristics

| Symbol | Ratings | Value | Unit |
|-----------|------------------------------|-------------|------|
| T_{STG} | Storage temperature range | -65 to +150 | °C |
| T_J | Maximum junction temperature | 150 | °C |

6.3 Operating conditions

6.3.1 General operating conditions

Table 23. General operating conditions

| Symbol | Parameter | Conditions | Min | Max | Unit |
|-------------|---|---|------|--------------|------|
| f_{HCLK} | Internal AHB clock frequency | - | 0 | 32 | MHz |
| f_{PCLK1} | Internal APB1 clock frequency | - | 0 | 32 | |
| f_{PCLK2} | Internal APB2 clock frequency | - | 0 | 32 | |
| V_{DD} | Standard operating voltage | BOR detector disabled | 1.65 | 3.6 | V |
| | | BOR detector enabled, at power on | 1.8 | 3.6 | |
| | | BOR detector disabled, after power on | 1.65 | 3.6 | |
| V_{DDA} | Analog operating voltage (all features) | Must be the same voltage as $V_{DD}^{(1)}$ | 1.8 | 3.6 | V |
| V_{DDIO2} | Standard operating voltage | | 1.65 | 3.6 | V |
| V_{IN} | Input voltage on FT, FTf and RST pins ⁽²⁾ | $2.0\text{ V} \leq V_{DD} \leq 3.6\text{ V}$ | -0.3 | 5.5 | V |
| | | $1.65\text{ V} \leq V_{DD} \leq 2.0\text{ V}$ | -0.3 | 5.2 | |
| | Input voltage on BOOT0 pin | - | 0 | 5.5 | |
| | Input voltage on TC pin | - | -0.3 | $V_{DD}+0.3$ | |
| P_D | Power dissipation at $T_A = 85\text{ °C}$ (range 6) or $T_A = 105\text{ °C}$ (range 7) ⁽³⁾ | TFBGA64 package | - | 327 | mW |
| | | LQFP64 package | - | 444 | |
| | | LQFP48 package | - | 363 | |
| | | WLCSP36 package | - | 318 | |
| | | LQFP32 package | - | 526 | |
| | | UFQFPN32 | - | 351 | |
| | Power dissipation at $T_A = 125\text{ °C}$ (range 3) ⁽³⁾ | TFBGA64 package | - | 81 | |
| | | LQFP64 package | - | 111 | |
| | | LQFP48 package | - | 91 | |
| | | WLCSP36 package | - | 79 | |
| | | LQFP32 package | - | 88 | |
| | | UFQFPN32 | - | 132 | |

Table 23. General operating conditions (continued)

| Symbol | Parameter | Conditions | Min | Max | Unit |
|----------------|--------------------------------------|-------------------------------------|-----|-----|------|
| T _A | Temperature range | Maximum power dissipation (range 6) | -40 | 85 | °C |
| | | Maximum power dissipation (range 7) | -40 | 105 | |
| | | Maximum power dissipation (range 3) | -40 | 125 | |
| T _J | Junction temperature range (range 6) | -40 °C ≤ T _A ≤ 85 ° | -40 | 105 | |
| | Junction temperature range (range 7) | -40 °C ≤ T _A ≤ 105 °C | -40 | 125 | |
| | Junction temperature range (range 3) | -40 °C ≤ T _A ≤ 125 °C | -40 | 130 | |

1. It is recommended to power V_{DD} and V_{DDA} from the same source. A maximum difference of 300 mV between V_{DD} and V_{DDA} can be tolerated during power-up and normal operation.
2. To sustain a voltage higher than V_{DD}+0.3V, the internal pull-up/pull-down resistors must be disabled.
3. If T_A is lower, higher P_D values are allowed as long as T_J does not exceed T_J max (see [Table 22: Thermal characteristics on page 49](#)).

6.3.2 Embedded reset and power control block characteristics

The parameters given in the following table are derived from the tests performed under the ambient temperature condition summarized in [Table 23](#).

Table 24. Embedded reset and power control block characteristics

| Symbol | Parameter | Conditions | Min | Typ | Max | Unit |
|--------------------------------------|-------------------------------------|---|------|------|------|------|
| t _{VDD} ⁽¹⁾ | V _{DD} rise time rate | BOR detector enabled | 0 | - | ∞ | μs/V |
| | | BOR detector disabled | 0 | - | 1000 | |
| | V _{DD} fall time rate | BOR detector enabled | 20 | - | ∞ | |
| | | BOR detector disabled | 0 | - | 1000 | |
| T _{RSTTEMPO} ⁽¹⁾ | Reset temporization | V _{DD} rising, BOR enabled | - | 2 | 3.3 | ms |
| | | V _{DD} rising, BOR disabled ⁽²⁾ | 0.4 | 0.7 | 1.6 | |
| V _{POR/PDR} | Power on/power down reset threshold | Falling edge | 1 | 1.5 | 1.65 | V |
| | | Rising edge | 1.3 | 1.5 | 1.65 | |
| V _{BOR0} | Brown-out reset threshold 0 | Falling edge | 1.67 | 1.7 | 1.74 | |
| | | Rising edge | 1.69 | 1.76 | 1.8 | |
| V _{BOR1} | Brown-out reset threshold 1 | Falling edge | 1.87 | 1.93 | 1.97 | |
| | | Rising edge | 1.96 | 2.03 | 2.07 | |
| V _{BOR2} | Brown-out reset threshold 2 | Falling edge | 2.22 | 2.30 | 2.35 | |
| | | Rising edge | 2.31 | 2.41 | 2.44 | |

Table 24. Embedded reset and power control block characteristics (continued)

| Symbol | Parameter | Conditions | Min | Typ | Max | Unit |
|-------------------|---|---|------|------|------|------|
| V _{BOR3} | Brown-out reset threshold 3 | Falling edge | 2.45 | 2.55 | 2.6 | V |
| | | Rising edge | 2.54 | 2.66 | 2.7 | |
| V _{BOR4} | Brown-out reset threshold 4 | Falling edge | 2.68 | 2.8 | 2.85 | |
| | | Rising edge | 2.78 | 2.9 | 2.95 | |
| V _{PVD0} | Programmable voltage detector threshold 0 | Falling edge | 1.8 | 1.85 | 1.88 | |
| | | Rising edge | 1.88 | 1.94 | 1.99 | |
| V _{PVD1} | PVD threshold 1 | Falling edge | 1.98 | 2.04 | 2.09 | |
| | | Rising edge | 2.08 | 2.14 | 2.18 | |
| V _{PVD2} | PVD threshold 2 | Falling edge | 2.20 | 2.24 | 2.28 | |
| | | Rising edge | 2.28 | 2.34 | 2.38 | |
| V _{PVD3} | PVD threshold 3 | Falling edge | 2.39 | 2.44 | 2.48 | |
| | | Rising edge | 2.47 | 2.54 | 2.58 | |
| V _{PVD4} | PVD threshold 4 | Falling edge | 2.57 | 2.64 | 2.69 | |
| | | Rising edge | 2.68 | 2.74 | 2.79 | |
| V _{PVD5} | PVD threshold 5 | Falling edge | 2.77 | 2.83 | 2.88 | |
| | | Rising edge | 2.87 | 2.94 | 2.99 | |
| V _{PVD6} | PVD threshold 6 | Falling edge | 2.97 | 3.05 | 3.09 | |
| | | Rising edge | 3.08 | 3.15 | 3.20 | |
| V _{hyst} | Hysteresis voltage | BOR0 threshold | - | 40 | - | mV |
| | | All BOR and PVD thresholds excepting BOR0 | - | 100 | - | |

1. Guaranteed by characterization results, not tested in production.
2. Valid for device version without BOR at power up. Please see option "D" in Ordering information scheme for more details.

6.3.3 Embedded internal reference voltage

The parameters given in [Table 26](#) are based on characterization results, unless otherwise specified.

Table 25. Embedded internal reference voltage calibration values

| Calibration value name | Description | Memory address |
|------------------------|---|---------------------------|
| VREFINT_CAL | Raw data acquired at temperature of 30 °C $V_{DDA} = 3\text{ V}$ | 0x1FF8 0078 - 0x1FF8 0079 |

Table 26. Embedded internal reference voltage⁽¹⁾

| Symbol | Parameter | Conditions | Min | Typ | Max | Unit |
|----------------------------------|---|--|-------|-------|-------|--------------------------|
| $V_{\text{REFINT_out}}^{(2)}$ | Internal reference voltage | $-40\text{ °C} < T_J < +125\text{ °C}$ | 1.202 | 1.224 | 1.242 | V |
| T_{VREFINT} | Internal reference startup time | - | - | 2 | 3 | ms |
| $V_{\text{VREF_MEAS}}$ | V_{DDA} and $V_{\text{REF+}}$ voltage during V_{REFINT} factory measure | - | 2.99 | 3 | 3.01 | V |
| $A_{\text{VREF_MEAS}}$ | Accuracy of factory-measured V_{REF} value ⁽³⁾ | Including uncertainties due to ADC and $V_{\text{DDA}}/V_{\text{REF+}}$ values | - | - | ±5 | mV |
| $T_{\text{Coeff}}^{(4)}$ | Temperature coefficient | $-40\text{ °C} < T_J < +125\text{ °C}$ | - | 20 | 50 | ppm/°C |
| | | $0\text{ °C} < T_J < +50\text{ °C}$ | - | - | 20 | |
| $A_{\text{Coeff}}^{(4)}$ | Long-term stability | 1000 hours, $T = 25\text{ °C}$ | - | - | 1000 | ppm |
| $V_{\text{DDCoeff}}^{(4)}$ | Voltage coefficient | $3.0\text{ V} < V_{\text{DDA}} < 3.6\text{ V}$ | - | - | 2000 | ppm/V |
| $T_{\text{S_vrefint}}^{(4)(5)}$ | ADC sampling time when reading the internal reference voltage | - | 5 | 10 | - | µs |
| $T_{\text{ADC_BUF}}^{(4)}$ | Startup time of reference voltage buffer for ADC | - | - | - | 10 | µs |
| $I_{\text{BUF_ADC}}^{(4)}$ | Consumption of reference voltage buffer for ADC | - | - | 13.5 | 25 | µA |
| $I_{\text{VREF_OUT}}^{(4)}$ | VREF_OUT output current ⁽⁶⁾ | - | - | - | 1 | µA |
| $C_{\text{VREF_OUT}}^{(4)}$ | VREF_OUT output load | - | - | - | 50 | pF |
| $I_{\text{LPBUF}}^{(4)}$ | Consumption of reference voltage buffer for VREF_OUT and COMP | - | - | 730 | 1200 | nA |
| $V_{\text{REFINT_DIV1}}^{(4)}$ | 1/4 reference voltage | - | 24 | 25 | 26 | % V_{REFINT} |
| $V_{\text{REFINT_DIV2}}^{(4)}$ | 1/2 reference voltage | - | 49 | 50 | 51 | |
| $V_{\text{REFINT_DIV3}}^{(4)}$ | 3/4 reference voltage | - | 74 | 75 | 76 | |

1. Refer to [Table 38: Peripheral current consumption in Stop and Standby mode](#) for the value of the internal reference current consumption (I_{REFINT}).
2. Guaranteed by test in production.
3. The internal V_{REF} value is individually measured in production and stored in dedicated EEPROM bytes.

4. Guaranteed by design, not tested in production.
5. Shortest sampling time can be determined in the application by multiple iterations.
6. To guarantee less than 1% VREF_OUT deviation.

6.3.4 Supply current characteristics

The current consumption is a function of several parameters and factors such as the operating voltage, temperature, I/O pin loading, device software configuration, operating frequencies, I/O pin switching rate, program location in memory and executed binary code. The current consumption is measured as described in [Figure 13: Current consumption measurement scheme](#).

All Run-mode current consumption measurements given in this section are performed with a reduced code that gives a consumption equivalent to Dhrystone 2.1 code if not specified otherwise.

The current consumption values are derived from the tests performed under ambient temperature and V_{DD} supply voltage conditions summarized in [Table 23: General operating conditions](#) unless otherwise specified.

The MCU is placed under the following conditions:

- All I/O pins are configured in analog input mode
- All peripherals are disabled except when explicitly mentioned
- The Flash memory access time and prefetch is adjusted depending on fHCLK frequency and voltage range to provide the best CPU performance unless otherwise specified.
- When the peripherals are enabled $f_{APB1} = f_{APB2} = f_{APB}$
- When PLL is on, the PLL inputs are equal to HSI = 16 MHz (if internal clock is used) or HSE = 16 MHz (if HSE bypass mode is used)
- The HSE user clock applied to OSCI_IN input follows the characteristic specified in [Table 40: High-speed external user clock characteristics](#)
- For maximum current consumption $V_{DD} = V_{DDA} = 3.6$ V is applied to all supply pins
- For typical current consumption $V_{DD} = V_{DDA} = 3.0$ V is applied to all supply pins if not specified otherwise

The parameters given in [Table 47](#), [Table 23](#) and [Table 24](#) are derived from tests performed under ambient temperature and V_{DD} supply voltage conditions summarized in [Table 23](#).

Table 27. Current consumption in Run mode, code with data processing running from Flash

| Symbol | Parameter | Conditions | | f _{HCLK} | Typ | Max ⁽¹⁾ | Unit |
|---|---|---|--|-------------------|-------|--------------------|------|
| I _{DD} (Run from Flash) | Supply current in Run mode, code executed from Flash | f _{HSE} = f _{HCLK} up to 16 MHz included, f _{HSE} = f _{HCLK} /2 above 16 MHz (PLL on) ⁽²⁾ | Range 3, V _{CORE} =1.2 V VOS[1:0]=11 | 1 MHz | 165 | 230 | μA |
| | | | | 2 MHz | 290 | 360 | |
| | | | | 4 MHz | 555 | 630 | |
| | | | Range 2, V _{CORE} =1.5 V, VOS[1:0]=10, | 4 MHz | 0.665 | 0.74 | mA |
| | | | | 8 MHz | 1.3 | 1.4 | |
| | | | | 16 MHz | 2.6 | 2.8 | |
| | | | Range 1, V _{CORE} =1.8 V, VOS[1:0]=01 | 8 MHz | 1.55 | 1.7 | |
| | | | | 16 MHz | 3.1 | 3.4 | |
| | | | | 32 MHz | 6.3 | 6.8 | |
| | | MSI clock | Range 3, V _{CORE} =1.2 V, VOS[1:0]=11 | 65 kHz | 36.5 | 110 | μA |
| | | | | 524 kHz | 99.5 | 190 | |
| | | | | 4.2 MHz | 620 | 700 | |
| HSI clock | Range 2, V _{CORE} =1.5 V, VOS[1:0]=10, | 16 MHz | 2.6 | 2.9 | mA | | |
| | | Range 1, V _{CORE} =1.8 V, VOS[1:0]=01 | 32 MHz | 6.25 | | 7 | |

1. Guaranteed by characterization results at 125 °C, not tested in production, unless otherwise specified.
2. Oscillator bypassed (HSEBYP = 1 in RCC_CR register).

Table 28. Current consumption in Run mode vs code type, code with data processing running from Flash

| Symbol | Parameter | Conditions | | f _{HCLK} | Typ | Unit | |
|---|---|---|--|---------------------------|-------|------|----|
| I _{DD} (Run from Flash) | Supply current in Run mode, code executed from Flash | f _{HSE} = f _{HCLK} up to 16 MHz included, f _{HSE} = f _{HCLK} /2 above 16 MHz (PLL on) ⁽¹⁾ | Range 3, V _{CORE} =1.2 V, VOS[1:0]=11 | Dhrystone | 4 MHz | 555 | μA |
| | | | | CoreMark | | 585 | |
| | | | | Fibonacci | | 440 | |
| | | | | while(1) | | 355 | |
| | | | | while(1), prefetch off | | 353 | |
| | | Range 1, VOS[1:0]=01, V _{CORE} =1.8 V | Dhrystone | 32 MHz | 6.3 | mA | |
| | | | CoreMark | | 6.3 | | |
| | | | Fibonacci | | 6.55 | | |
| | | | while(1) | | 5.4 | | |
| | | | while(1), prefetch off | | 5.2 | | |

1. Oscillator bypassed (HSEBYP = 1 in RCC_CR register).

Figure 14. I_{DD} vs V_{DD} , at $T_A = 25/55/85/105^\circ\text{C}$, Run mode, code running from Flash memory, Range 2, HSE, 1WS

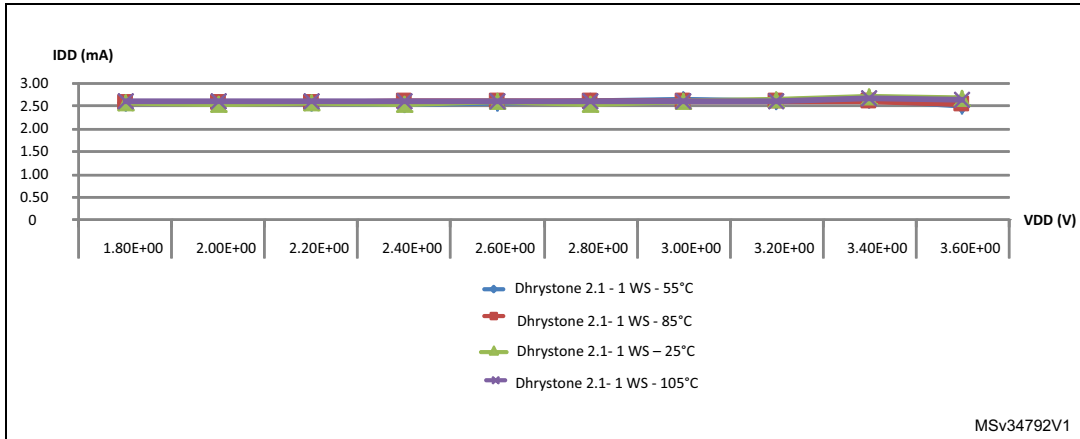


Figure 15. I_{DD} vs V_{DD} , at $T_A = 25/55/85/105^\circ\text{C}$, Run mode, code running from Flash memory, Range 2, HSI16, 1WS

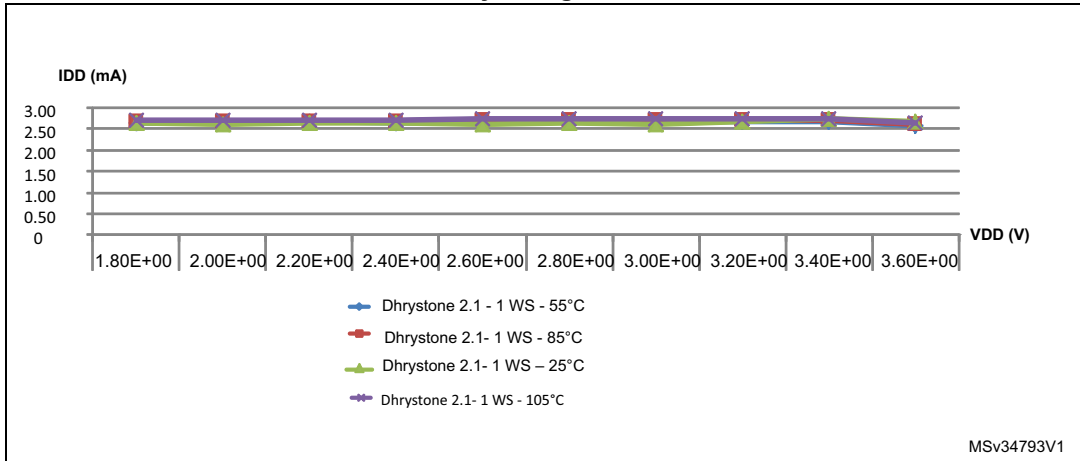


Table 29. Current consumption in Run mode, code with data processing running from RAM

| Symbol | Parameter | Conditions | | f _{HCLK} | Typ | Max ⁽¹⁾ | Unit |
|--------------------------------|--|---|--|-------------------|------|--------------------|------|
| I _{DD} (Run from RAM) | Supply current in Run mode, code executed from RAM, Flash switched off | f _{HSE} = f _{HCLK} up to 16 MHz, included f _{HSE} = f _{HCLK} /2 above 16 MHz (PLL on) ⁽²⁾ | Range 3, V _{CORE} =1.2 V, VOS[1:0]=11 | 1 MHz | 135 | 170 | μA |
| | | | | 2 MHz | 240 | 270 | |
| | | | | 4 MHz | 450 | 480 | |
| | | | Range 2, V _{CORE} =1.5 V, VOS[1:0]=10 | 4 MHz | 0.52 | 0.6 | mA |
| | | | | 8 MHz | 1 | 1.2 | |
| | | | | 16 MHz | 2 | 2.3 | |
| | | Range 1, V _{CORE} =1.8 V, VOS[1:0]=01 | 8 MHz | 1.25 | 1.4 | mA | |
| | | | 16 MHz | 2.45 | 2.8 | | |
| | | | 32 MHz | 5.1 | 5.4 | | |
| | | MSI clock | Range 3, V _{CORE} =1.2 V, VOS[1:0]=11 | 65 kHz | 34.5 | 75 | μA |
| | | | | 524 kHz | 83 | 120 | |
| | | | | 4.2 MHz | 485 | 540 | |
| HSI16 clock source (16 MHz) | Range 2, V _{CORE} =1.5 V, VOS[1:0]=10 | 16 MHz | 2.1 | 2.3 | mA | | |
| | | Range 1, V _{CORE} =1.8 V, VOS[1:0]=01 | 32 MHz | 5.1 | | 5.6 | |

1. Guaranteed by characterization results at 125 °C, not tested in production, unless otherwise specified.
2. Oscillator bypassed (HSEBYP = 1 in RCC_CR register).

Table 30. Current consumption in Run mode vs code type, code with data processing running from RAM⁽¹⁾

| Symbol | Parameter | Conditions | | f _{HCLK} | Typ | Unit | |
|--------------------------------|--|--|--|-------------------|-----------|------|------|
| I _{DD} (Run from RAM) | Supply current in Run mode, code executed from RAM, Flash switched off | f _{HSE} = f _{HCLK} up to 16 MHz, included, f _{HSE} = f _{HCLK} /2 above 16 MHz (PLL on) ⁽²⁾ | Range 3, V _{CORE} =1.2 V, VOS[1:0]=11 | Dhystone | 4 MHz | 450 | μA |
| | | | | CoreMark | | 575 | |
| | | | | Fibonacci | | 370 | |
| | | | | while(1) | | 340 | |
| | | Range 1, V _{CORE} =1.8 V, VOS[1:0]=01 | Dhystone | 32 MHz | 5.1 | mA | |
| | | | | | CoreMark | | 6.25 |
| | | | | | Fibonacci | | 4.4 |
| | | | | | while(1) | | 4.7 |

1. Guaranteed by characterization results, not tested in production, unless otherwise specified.
2. Oscillator bypassed (HSEBYP = 1 in RCC_CR register).

Table 31. Current consumption in Sleep mode

| Symbol | Parameter | Conditions | f _{HCLK} | Typ | Max ⁽¹⁾ | Unit | |
|-----------------------------|--|--|--|---------|--------------------|------|----|
| I _{DD} (Sleep) | Supply current in Sleep mode, Flash off | f _{HSE} = f _{HCLK} up to 16 MHz included, f _{HSE} = f _{HCLK} /2 above 16 MHz (PLL on) ⁽²⁾ | Range 3, V _{CORE} =1.2 V, VOS[1:0]=11 | 1 MHz | 43.5 | 90 | μA |
| | | | | 2 MHz | 72 | 120 | |
| | | | | 4 MHz | 130 | 180 | |
| | | | Range 2, V _{CORE} =1.5 V, VOS[1:0]=10 | 4 MHz | 160 | 210 | |
| | | | | 8 MHz | 305 | 370 | |
| | | | | 16 MHz | 590 | 710 | |
| | | | Range 1, V _{CORE} =1.8 V, VOS[1:0]=01 | 8 MHz | 370 | 430 | |
| | | | | 16 MHz | 715 | 860 | |
| | | | | 32 MHz | 1650 | 1900 | |
| | | MSI clock | Range 3, V _{CORE} =1.2 V, VOS[1:0]=11 | 65 kHz | 18 | 65 | |
| | | | | 524 kHz | 31.5 | 75 | |
| | | | | 4.2 MHz | 140 | 210 | |
| | HSI16 clock source (16 MHz) | Range 2, V _{CORE} =1.5 V, VOS[1:0]=10 | 16 MHz | 665 | 830 | | |
| | | Range 1, V _{CORE} =1.8 V, VOS[1:0]=01 | 32 MHz | 1750 | 2100 | | |
| | Supply current in Sleep mode, Flash on | f _{HSE} = f _{HCLK} up to 16 MHz included, f _{HSE} = f _{HCLK} /2 above 16 MHz (PLL on) ⁽²⁾ | Range 3, V _{CORE} =1.2 V, VOS[1:0]=11 | 1 MHz | 57.5 | 130 | |
| | | | | 2 MHz | 84 | 170 | |
| | | | | 4 MHz | 150 | 280 | |
| | | | Range 2, V _{CORE} =1.5 V, VOS[1:0]=10 | 4 MHz | 170 | 310 | |
| | | | | 8 MHz | 315 | 420 | |
| | | | | 16 MHz | 605 | 770 | |
| | | | Range 1, V _{CORE} =1.8 V, VOS[1:0]=01 | 8 MHz | 380 | 460 | |
| | | | | 16 MHz | 730 | 950 | |
| | | | | 32 MHz | 1650 | 2400 | |
| | | MSI clock | Range 3, V _{CORE} =1.2 V, VOS[1:0]=11 | 65 kHz | 29.5 | 110 | |
| | | | 524 kHz | 44.5 | 130 | | |
| | | | 4.2 MHz | 150 | 270 | | |
| HSI16 clock source (16 MHz) | Range 2, V _{CORE} =1.5 V, VOS[1:0]=10 | 16 MHz | 680 | 950 | | | |
| | Range 1, V _{CORE} =1.8 V, VOS[1:0]=01 | 32 MHz | 1750 | 2100 | | | |

1. Guaranteed by characterization results at 125 °C, not tested in production, unless otherwise specified.

2. Oscillator bypassed (HSEBYP = 1 in RCC_CR register).

Table 32. Current consumption in Low-power Run mode

| Symbol | Parameter | Conditions | | Typ | Max ⁽¹⁾ | Unit | |
|-----------------------------|--------------------------------------|---|---|----------------------------------|--------------------|------|----|
| I _{DD} (LP Run) | Supply current in Low-power run mode | All peripherals off, code executed from RAM, Flash switched off, V _{DD} from 1.65 V to 3.6 V | MSI clock, 65 kHz f _{HCLK} = 32 kHz | T _A = -40 °C to 25 °C | 8.5 | 10 | μA |
| | | | | T _A = 85 °C | 11.5 | 48 | |
| | | | | T _A = 105 °C | 15.5 | 53 | |
| | | | | T _A = 125 °C | 27.5 | 130 | |
| | | | MSI clock, 65 kHz f _{HCLK} = 65 kHz | T _A = -40 °C to 25 °C | 10 | 15 | |
| | | | | T _A = 85 °C | 15.5 | 50 | |
| | | | | T _A = 105 °C | 19.5 | 54 | |
| | | | | T _A = 125 °C | 31.5 | 130 | |
| | | | MSI clock, 131 kHz f _{HCLK} = 131 kHz | T _A = -40 °C to 25 °C | 20 | 25 | |
| | | | | T _A = 55 °C | 23 | 50 | |
| | | | | T _A = 85 °C | 25.5 | 55 | |
| | | | | T _A = 105 °C | 29.5 | 64 | |
| | | All peripherals off, code executed from Flash, V _{DD} from 1.65 V to 3.6 V | MSI clock, 65 kHz f _{HCLK} = 32 kHz | T _A = -40 °C to 25 °C | 22 | 28 | |
| | | | | T _A = 85 °C | 26 | 68 | |
| | | | | T _A = 105 °C | 31 | 75 | |
| | | | | T _A = 125 °C | 44 | 95 | |
| | | | MSI clock, 65 kHz f _{HCLK} = 65 kHz | T _A = -40 °C to 25 °C | 27.5 | 33 | |
| | | | | T _A = 85 °C | 31.5 | 73 | |
| | | | | T _A = 105 °C | 36.5 | 80 | |
| | | | | T _A = 125 °C | 49 | 100 | |
| | | | MSI clock, 131 kHz f _{HCLK} = 131 kHz | T _A = -40 °C to 25 °C | 39 | 46 | |
| | | | | T _A = 55 °C | 41 | 80 | |
| | | | | T _A = 85 °C | 44 | 86 | |
| | | | | T _A = 105 °C | 49.5 | 100 | |
| | | T _A = 125 °C | 60 | 120 | | | |

1. Guaranteed by characterization results at 125 °C, not tested in production, unless otherwise specified.

Figure 16. I_{DD} vs V_{DD} , at $T_A = 25/55/ 85/105/125$ °C, Low-power run mode, code running from RAM, Range 3, MSI (Range 0) at 64 KHz, 0 WS

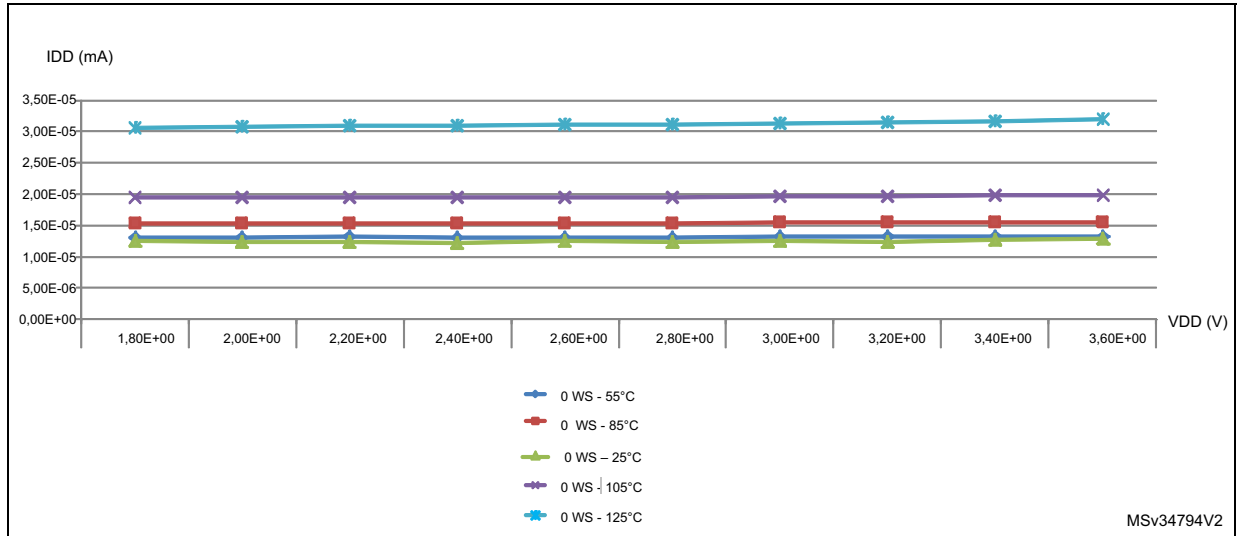


Table 33. Current consumption in Low-power Sleep mode

| Symbol | Parameter | Conditions | Typ | Max ⁽¹⁾ | Unit | | |
|------------------------|--|--|---|-------------------------|--------------------|----|---------|
| I_{DD} (LP Sleep) | Supply current in Low-power sleep mode | All peripherals off, V_{DD} from 1.65 V to 3.6 V | MSI clock, 65 kHz $f_{HCLK} = 32$ kHz Flash off | $T_A = -40$ °C to 25 °C | 4.7 ⁽²⁾ | - | μA |
| | | | MSI clock, 65 kHz $f_{HCLK} = 32$ kHz Flash on | $T_A = -40$ °C to 25 °C | 17 | 23 | |
| | | | | $T_A = 85$ °C | 19.5 | 63 | |
| | | | | $T_A = 105$ °C | 23 | 69 | |
| | | | | $T_A = 125$ °C | 32.5 | 90 | |
| | | | MSI clock, 65 kHz $f_{HCLK} = 65$ kHz, Flash on | $T_A = -40$ °C to 25 °C | 17 | 23 | |
| | | | | $T_A = 85$ °C | 20 | 63 | |
| | | | | $T_A = 105$ °C | 23.5 | 69 | |
| | | | MSI clock, 131 kHz $f_{HCLK} = 131$ kHz, Flash on | $T_A = 125$ °C | 32.5 | 90 | |
| | | | | $T_A = -40$ °C to 25 °C | 19.5 | 36 | |
| | | | | $T_A = 55$ °C | 20.5 | 64 | |
| | | | | $T_A = 85$ °C | 22.5 | 66 | |
| | | | | $T_A = 105$ °C | 26 | 72 | |
| | | | | $T_A = 125$ °C | 35 | 95 | |

1. Guaranteed by characterization results at 125 °C, not tested in production, unless otherwise specified.
2. As the CPU is in Sleep mode, the difference between the current consumption with Flash on and off (nearly 12 μA) is the same whatever the clock frequency.

Table 34. Typical and maximum current consumptions in Stop mode

| Symbol | Parameter | Conditions | Typ | Max ⁽¹⁾ | Unit |
|------------------------|-----------------------------|--------------------------------|------|--------------------|------|
| I _{DD} (Stop) | Supply current in Stop mode | T _A = -40°C to 25°C | 0.41 | 1 | μA |
| | | T _A = 55°C | 0.63 | 2.1 | |
| | | T _A = 85°C | 1.7 | 4.5 | |
| | | T _A = 105°C | 4 | 9.6 | |
| | | T _A = 125°C | 11 | 24 ⁽²⁾ | |

1. Guaranteed by characterization results at 125 °C, not tested in production, unless otherwise specified.
2. Guaranteed by test in production.

Figure 17. I_{DD} vs V_{DD}, at T_A= 25/55/ 85/105/125 °C, Stop mode with RTC enabled and running on LSE Low drive

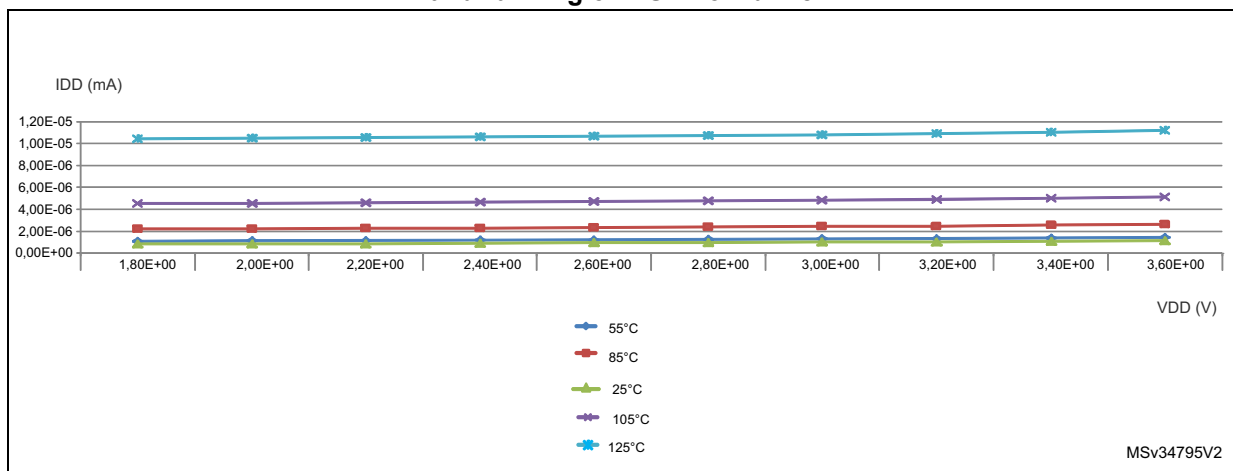


Figure 18. I_{DD} vs V_{DD}, at T_A= 25/55/85/105/125 °C, Stop mode with RTC disabled, all clocks off

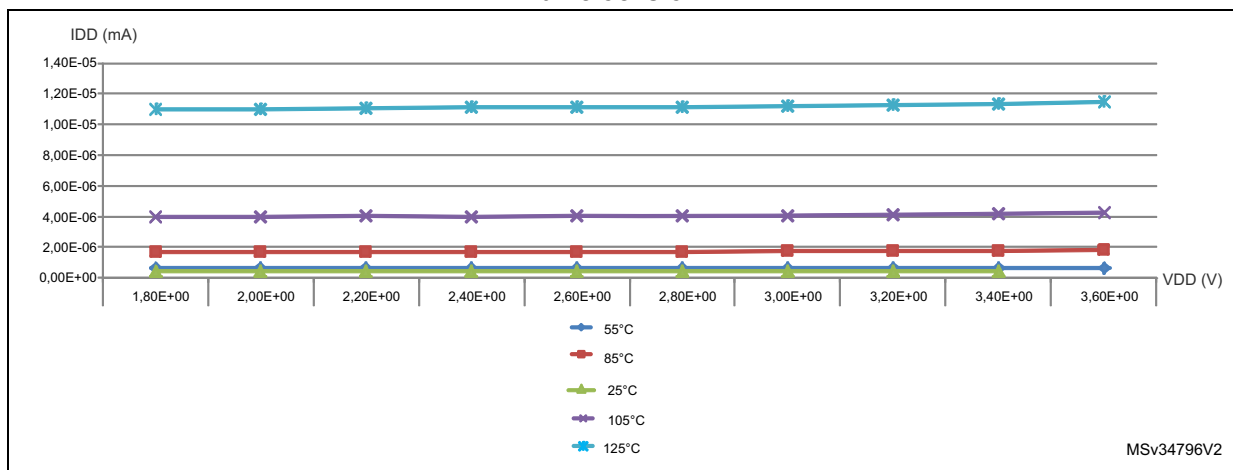


Table 35. Typical and maximum current consumptions in Standby mode

| Symbol | Parameter | Conditions | | Typ | Max ⁽¹⁾ | Unit |
|------------------------------|--------------------------------|--------------------------------------|----------------------------------|------|--------------------|------|
| I _{DD} (Standby) | Supply current in Standby mode | Independent watchdog and LSI enabled | T _A = -40 °C to 25 °C | 1.3 | 1.7 | μA |
| | | | T _A = 55 °C | - | 2.9 | |
| | | | T _A = 85 °C | - | 3.3 | |
| | | | T _A = 105 °C | - | 4.1 | |
| | | | T _A = 125 °C | - | 8.5 | |
| | | Independent watchdog and LSI off | T _A = -40 °C to 25 °C | 0.29 | 0.6 | |
| | | | T _A = 55 °C | 0.32 | 0.9 | |
| | | | T _A = 85 °C | 0.5 | 2.3 | |
| | | | T _A = 105 °C | 0.94 | 3 | |
| | | | T _A = 125 °C | 2.6 | 7 | |

1. Guaranteed by characterization results at 125 °C, not tested in production, unless otherwise specified

Table 36. Average current consumption during wakeup

| Symbol | parameter | System frequency | Current consumption during wakeup | Unit |
|-----------------------------------|---|------------------|-----------------------------------|------|
| I _{DD} (WU from Stop) | Supply current during wakeup from Stop mode | HSI | 1 | mA |
| | | HSI/4 | 0,7 | |
| | | MSI 4,2 MHz | 0,7 | |
| | | MSI 1,05 MHz | 0,4 | |
| | | MSI 65 KHz | 0,1 | |
| I _{DD} (Reset) | Reset pin pulled down | - | 0,21 | |
| I _{DD} (Power Up) | BOR on | - | 0,23 | |
| I _{DD} (WU from StandBy) | With Fast wakeup set | MSI 2,1 MHz | 0,5 | |
| | With Fast wakeup disabled | MSI 2,1 MHz | 0,12 | |

On-chip peripheral current consumption

The current consumption of the on-chip peripherals is given in the following tables. The MCU is placed under the following conditions:

- all I/O pins are in input mode with a static value at V_{DD} or V_{SS} (no load)
- all peripherals are disabled unless otherwise mentioned
- the given value is calculated by measuring the current consumption
 - with all peripherals clocked off
 - with only one peripheral clocked on



Table 37. Peripheral current consumption in run or Sleep mode⁽¹⁾

| Peripheral | | Typical consumption, V _{DD} = 3.0 V, T _A = 25 °C | | | | Unit |
|--------------------------|---------------------|--|---|---|-------------------------------|--------------------------------|
| | | Range 1, V _{CORE} =1.8 V VOS[1:0] = 01 | Range 2, V _{CORE} =1.5 V VOS[1:0] = 10 | Range 3, V _{CORE} =1.2 V VOS[1:0] = 11 | Low-power sleep and run | |
| APB1 | WWDG | 3 | 2 | 2 | 2 | μA/MHz (f _{HCLK}) |
| | SPI2 | 9 | 4.5 | 3.5 | 4 | |
| | LPUART1 | 8 | 6.5 | 5.5 | 6 | |
| | I2C1 | 11 | 9.5 | 7.5 | 9 | |
| | I2C2 | 4 | 3.5 | 3 | 2.5 | |
| | USART2 | 14.5 | 12 | 9.5 | 11 | |
| | LPTIM1 | 10 | 8.5 | 6.5 | 8 | |
| | TIM2 | 10.5 | 8.5 | 7 | 9 | |
| | TIM6 | 3.5 | 3 | 2.5 | 2 | |
| | CRS | 2.5 | 2 | 2 | 2 | |
| APB2 | ADC1 ⁽²⁾ | 5.5 | 5 | 3.5 | 4 | μA/MHz (f _{HCLK}) |
| | SPI1 | 4 | 3 | 3 | 2.5 | |
| | USART1 | 14.5 | 11.5 | 9.5 | 12 | |
| | TIM21 | 7.5 | 6 | 5 | 5.5 | |
| | TIM22 | 7 | 6 | 5 | 6 | |
| | FIREWALL | 1.5 | 1 | 1 | 0.5 | |
| | DBGMCU | 1.5 | 1 | 1 | 0.5 | |
| | SYSCFG | 2.5 | 2 | 2 | 1.5 | |
| Cortex-M0+ core I/O port | GPIOA | 3.5 | 3 | 2.5 | 2.5 | μA/MHz (f _{HCLK}) |
| | GPIOB | 3.5 | 2.5 | 2 | 2.5 | |
| | GPIOC | 8.5 | 6.5 | 5.5 | 7 | |
| | GPIOD | 1 | 0.5 | 0.5 | 0.5 | |
| | GPIOH | 1.5 | 1 | 1 | 0.5 | |
| AHB | CRC | 1.5 | 1 | 1 | 1 | μA/MHz (f _{HCLK}) |
| | FLASH | 0 ⁽³⁾ | 0 ⁽³⁾ | 0 ⁽³⁾ | 0 ⁽³⁾ | |
| | DMA1 | 10 | 8 | 6.5 | 8.5 | |
| | RNG | 5.5 | 1 | 0.5 | 0.5 | |
| | TSC | 3 | 2.5 | 2 | 3 | |
| All enabled | | 279 | 221.5 | 219.5 | 215 | |
| PWR | | 2.5 | 2 | 2 | 1 | μA/MHz (f _{HCLK}) |

1. Data based on differential I_{DD} measurement between all peripherals off an one peripheral with clock enabled, in the following conditions: $f_{HCLK} = 32$ MHz (range 1), $f_{HCLK} = 16$ MHz (range 2), $f_{HCLK} = 4$ MHz (range 3), $f_{HCLK} = 64$ kHz (Low-power run/sleep), $f_{APB1} = f_{HCLK}$, $f_{APB2} = f_{HCLK}$, default prescaler value for each peripheral. The CPU is in Sleep mode in both cases. No I/O pins toggling. Not tested in production.
2. HSI oscillator is off for this measure.
3. Current consumption is negligible and close to 0 μ A.

Table 38. Peripheral current consumption in Stop and Standby mode

| Symbol | Peripheral | Typical consumption, $T_A = 25\text{ }^\circ\text{C}$ | | Unit |
|---------------------|------------------------------|---|-----------------------|---------|
| | | $V_{DD}=1.8\text{ V}$ | $V_{DD}=3.0\text{ V}$ | |
| $I_{DD(PVD / BOR)}$ | - | 0.7 | 1.2 | μ A |
| I_{REFINT} | - | - | 1.4 | |
| - | LSE Low drive ⁽¹⁾ | 0,1 | 0,1 | |
| - | LPTIM1, Input 100 Hz | 0,01 | 0,01 | |
| - | LPTIM1, Input 1 MHz | 6 | 6 | |
| - | LPUART1 | 0,2 | 0,2 | |
| - | RTC | 0,3 | 0,48 | |

1. LSE Low drive consumption is the difference between an external clock on OSC32_IN and a quartz between OSC32_IN and OSC32_OUT.-

6.3.5 Wakeup time from low-power mode

The wakeup times given in the following table are measured with the MSI or HSI16 RC oscillator. The clock source used to wake up the device depends on the current operating mode:

- Sleep mode: the clock source is the clock that was set before entering Sleep mode
- Stop mode: the clock source is either the MSI oscillator in the range configured before entering Stop mode, the HSI16 or HSI16/4.
- Standby mode: the clock source is the MSI oscillator running at 2.1 MHz

All timings are derived from tests performed under ambient temperature and V_{DD} supply voltage conditions summarized in [Table 23](#).

Table 39. Low-power mode wakeup timings

| Symbol | Parameter | Conditions | Typ | Unit |
|--|--|---|---------------------------------------|---------------|
| $t_{WUSLEEP}$ | Wakeup from Sleep mode | $f_{HCLK} = 32 \text{ MHz}$ | 0.42 | μs |
| $t_{WUSLEEP_LP}$ | Wakeup from Low-power sleep mode, $f_{HCLK} = 262 \text{ kHz}$ | $f_{HCLK} = 262 \text{ kHz}$ Flash enabled | 4.5 | |
| | | $f_{HCLK} = 262 \text{ kHz}$ Flash switched off | 7.7 | |
| t_{WUSTOP} | Wakeup from Stop mode, regulator in Run mode | $f_{HCLK} = f_{MSI} = 4.2 \text{ MHz}$ | 5.09 | |
| | | $f_{HCLK} = f_{HSI} = 16 \text{ MHz}$ | 4.90 | |
| | | $f_{HCLK} = f_{HSI}/4 = 4 \text{ MHz}$ | 7.93 | |
| | Wakeup from Stop mode, regulator in low-power mode | $f_{HCLK} = f_{MSI} = 4.2 \text{ MHz}$ Voltage range 1 | 5.13 | |
| | | $f_{HCLK} = f_{MSI} = 4.2 \text{ MHz}$ Voltage range 2 | 5.09 | |
| | | $f_{HCLK} = f_{MSI} = 4.2 \text{ MHz}$ Voltage range 3 | 5.08 | |
| | | $f_{HCLK} = f_{MSI} = 2.1 \text{ MHz}$ | 7.5 | |
| | | $f_{HCLK} = f_{MSI} = 1.05 \text{ MHz}$ | 13.5 | |
| | | $f_{HCLK} = f_{MSI} = 524 \text{ kHz}$ | 27.6 | |
| | | $f_{HCLK} = f_{MSI} = 262 \text{ kHz}$ | 51.7 | |
| | | $f_{HCLK} = f_{MSI} = 131 \text{ kHz}$ | 102.3 | |
| | | $f_{HCLK} = f_{MSI} = 65 \text{ kHz}$ | 197.2 | |
| | | $f_{HCLK} = f_{HSI} = 16 \text{ MHz}$ | 4.80 | |
| | | $f_{HCLK} = f_{HSI}/4 = 4 \text{ MHz}$ | 7.95 | |
| | | Wakeup from Stop mode, regulator in low-power mode, code running from RAM | $f_{HCLK} = f_{HSI} = 16 \text{ MHz}$ | |
| $f_{HCLK} = f_{HSI}/4 = 4 \text{ MHz}$ | 8.04 | | | |
| $f_{HCLK} = f_{MSI} = 4.2 \text{ MHz}$ | 5.06 | | | |
| $t_{WUSTDBY}$ | Wakeup from Standby mode FWU bit = 1 | $f_{HCLK} = f_{MSI} = 2.1 \text{ MHz}$ | 67.5 | ms |
| | Wakeup from Standby mode FWU bit = 0 | $f_{HCLK} = f_{MSI} = 2.1 \text{ MHz}$ | 2.56 | |

6.3.6 External clock source characteristics

High-speed external user clock generated from an external source

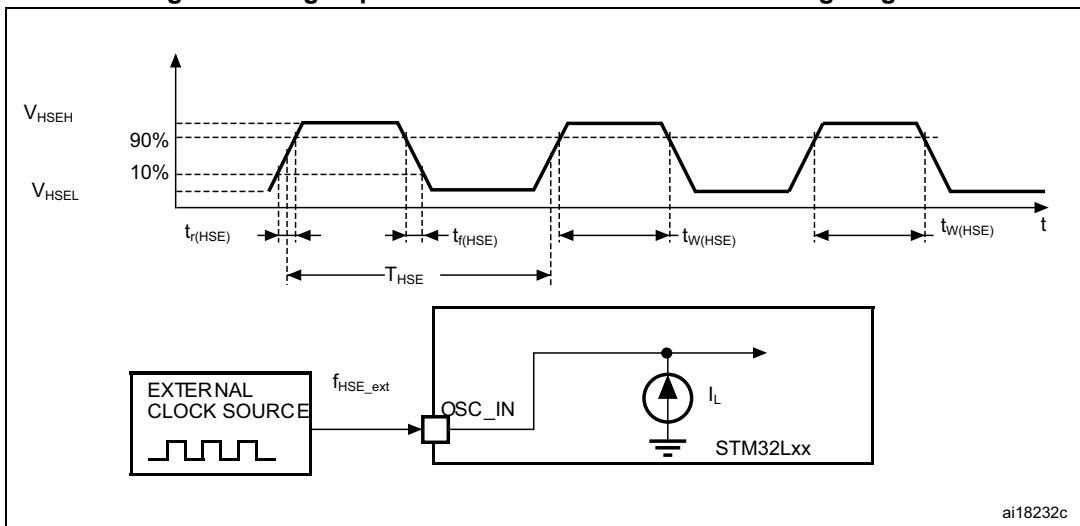
In bypass mode the HSE oscillator is switched off and the input pin is a standard GPIO. The external clock signal has to respect the I/O characteristics in [Section 6.3.12](#). However, the recommended clock input waveform is shown in [Figure 19](#).

Table 40. High-speed external user clock characteristics⁽¹⁾

| Symbol | Parameter | Conditions | Min | Typ | Max | Unit | |
|------------------------------|--------------------------------------|--------------------------|----------------------------------|-----|-------------|---------|---------|
| f_{HSE_ext} | User external clock source frequency | CSS is on or PLL is used | 1 | 8 | 32 | MHz | |
| | | CSS is off, PLL not used | 0 | 8 | 32 | MHz | |
| V_{HSEH} | OSC_IN input pin high level voltage | - | $0.7V_{DD}$ | - | V_{DD} | V | |
| V_{HSEL} | OSC_IN input pin low level voltage | | V_{SS} | - | $0.3V_{DD}$ | | |
| $t_{w(HSE)}$ $t_{w(HSE)}$ | OSC_IN high or low time | | 12 | - | - | ns | |
| $t_{r(HSE)}$ $t_{r(HSE)}$ | OSC_IN rise or fall time | | - | - | 20 | | |
| $C_{in(HSE)}$ | OSC_IN input capacitance | | - | 2.6 | - | | pF |
| $DuCy_{(HSE)}$ | Duty cycle | | | 45 | - | 55 | % |
| I_L | OSC_IN Input leakage current | | $V_{SS} \leq V_{IN} \leq V_{DD}$ | - | - | ± 1 | μA |

1. Guaranteed by design, not tested in production.

Figure 19. High-speed external clock source AC timing diagram



Low-speed external user clock generated from an external source

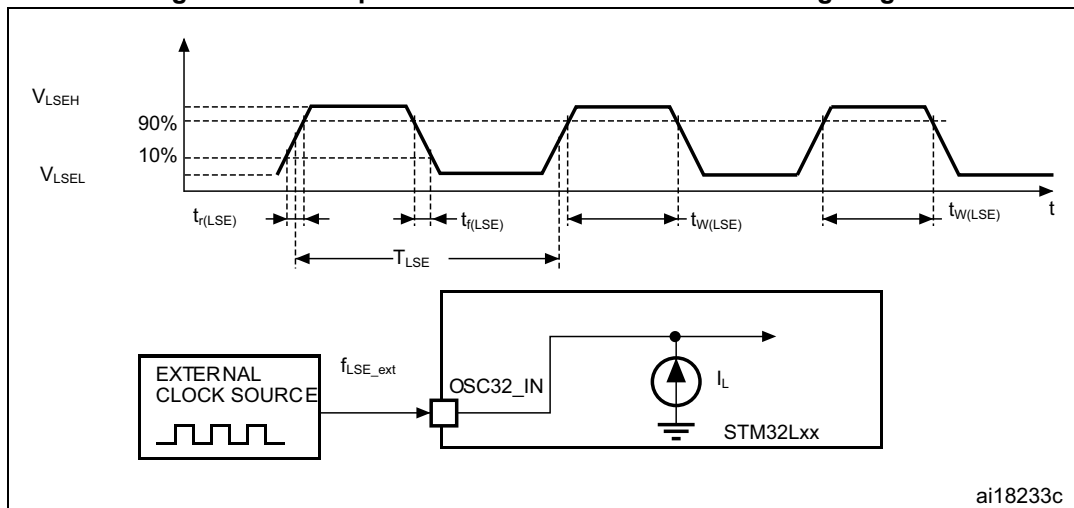
The characteristics given in the following table result from tests performed using a low-speed external clock source, and under ambient temperature and supply voltage conditions summarized in [Table 23](#).

Table 41. Low-speed external user clock characteristics⁽¹⁾

| Symbol | Parameter | Conditions | Min | Typ | Max | Unit |
|------------------------------|---------------------------------------|----------------------------------|-------------|--------|-------------|---------|
| f_{LSE_ext} | User external clock source frequency | | 1 | 32.768 | 1000 | kHz |
| V_{LSEH} | OSC32_IN input pin high level voltage | - | $0.7V_{DD}$ | - | V_{DD} | V |
| V_{LSEL} | OSC32_IN input pin low level voltage | | V_{SS} | - | $0.3V_{DD}$ | |
| $t_{w(LSE)}$ $t_{w(LSE)}$ | OSC32_IN high or low time | | 465 | - | - | ns |
| $t_{r(LSE)}$ $t_{f(LSE)}$ | OSC32_IN rise or fall time | - | - | 10 | | |
| $C_{IN(LSE)}$ | OSC32_IN input capacitance | - | - | 0.6 | - | pF |
| $DuCy_{(LSE)}$ | Duty cycle | - | 45 | - | 55 | % |
| I_L | OSC32_IN Input leakage current | $V_{SS} \leq V_{IN} \leq V_{DD}$ | - | - | ± 1 | μA |

1. Guaranteed by design, not tested in production

Figure 20. Low-speed external clock source AC timing diagram



High-speed external clock generated from a crystal/ceramic resonator

The high-speed external (HSE) clock can be supplied with a 1 to 25 MHz crystal/ceramic resonator oscillator. All the information given in this paragraph are based on characterization results obtained with typical external components specified in [Table 42](#). In the application, the resonator and the load capacitors have to be placed as close as possible to the oscillator pins in order to minimize output distortion and startup stabilization

time. Refer to the crystal resonator manufacturer for more details on the resonator characteristics (frequency, package, accuracy).

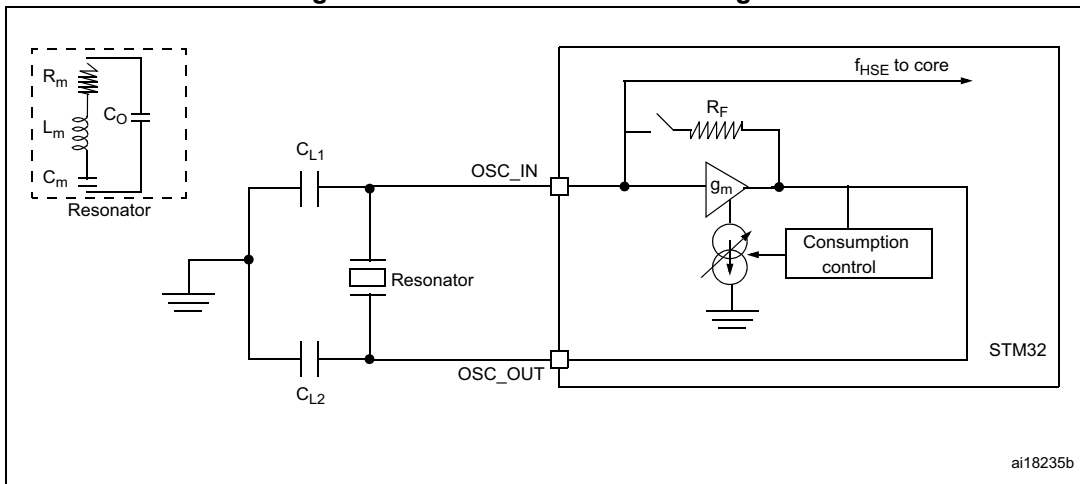
Table 42. HSE oscillator characteristics⁽¹⁾

| Symbol | Parameter | Conditions | Min | Typ | Max | Unit |
|---------------------|---|------------------------|-----|-----|-----|------------|
| f_{OSC_IN} | Oscillator frequency | - | 1 | | 25 | MHz |
| R_F | Feedback resistor | - | - | 200 | - | k Ω |
| G_m | Maximum critical crystal transconductance | Startup | - | - | 700 | $\mu A/V$ |
| $t_{SU(HSE)}^{(2)}$ | Startup time | V_{DD} is stabilized | - | 2 | - | ms |

1. Guaranteed by design, not tested in production.
2. Guaranteed by characterization results, not tested in production. $t_{SU(HSE)}$ is the startup time measured from the moment it is enabled (by software) to a stabilized 8 MHz oscillation is reached. This value is measured for a standard crystal resonator and it can vary significantly with the crystal manufacturer.

For C_{L1} and C_{L2} , it is recommended to use high-quality external ceramic capacitors in the 5 pF to 25 pF range (typ.), designed for high-frequency applications, and selected to match the requirements of the crystal or resonator (see [Figure 21](#)). C_{L1} and C_{L2} are usually the same size. The crystal manufacturer typically specifies a load capacitance which is the series combination of C_{L1} and C_{L2} . PCB and MCU pin capacitance must be included (10 pF can be used as a rough estimate of the combined pin and board capacitance) when sizing C_{L1} and C_{L2} . Refer to the application note AN2867 “Oscillator design guide for ST microcontrollers” available from the ST website www.st.com.

Figure 21. HSE oscillator circuit diagram



Low-speed external clock generated from a crystal/ceramic resonator

The low-speed external (LSE) clock can be supplied with a 32.768 kHz crystal/ceramic resonator oscillator. All the information given in this paragraph are based on characterization results obtained with typical external components specified in [Table 43](#). In the application, the resonator and the load capacitors have to be placed as close as possible to the oscillator pins in order to minimize output distortion and startup stabilization

time. Refer to the crystal resonator manufacturer for more details on the resonator characteristics (frequency, package, accuracy).

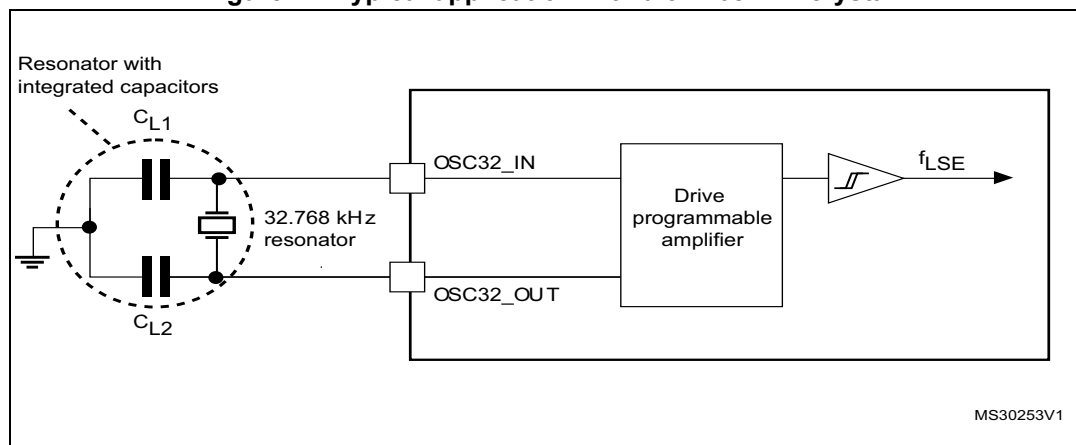
Table 43. LSE oscillator characteristics⁽¹⁾

| Symbol | Parameter | Conditions ⁽²⁾ | Min ⁽²⁾ | Typ | Max | Unit |
|------------------------------|---|--|--------------------|--------|------|-----------|
| f_{LSE} | LSE oscillator frequency | | - | 32.768 | - | kHz |
| G_m | Maximum critical crystal transconductance | LSEDRV[1:0]=00 lower driving capability | - | - | 0.5 | $\mu A/V$ |
| | | LSEDRV[1:0]=01 medium low driving capability | - | - | 0.75 | |
| | | LSEDRV[1:0]=10 medium high driving capability | - | - | 1.7 | |
| | | LSEDRV[1:0]=11 higher driving capability | - | - | 2.7 | |
| $t_{SU(LSE)}$ ⁽³⁾ | Startup time | V_{DD} is stabilized | - | 2 | - | s |

1. Guaranteed by design, not tested in production.
2. Refer to the note and caution paragraphs below the table, and to the application note AN2867 "Oscillator design guide for ST microcontrollers".
3. Guaranteed by characterization results, not tested in production. $t_{SU(LSE)}$ is the startup time measured from the moment it is enabled (by software) to a stabilized 32.768 kHz oscillation is reached. This value is measured for a standard crystal resonator and it can vary significantly with the crystal manufacturer. To increase speed, address a lower-drive quartz with a high-driver mode.

Note: For information on selecting the crystal, refer to the application note AN2867 "Oscillator design guide for ST microcontrollers" available from the ST website www.st.com.

Figure 22. Typical application with a 32.768 kHz crystal



Note: An external resistor is not required between $OSC32_IN$ and $OSC32_OUT$ and it is forbidden to add one.

6.3.7 Internal clock source characteristics

The parameters given in [Table 44](#) are derived from tests performed under ambient temperature and V_{DD} supply voltage conditions summarized in [Table 23](#).

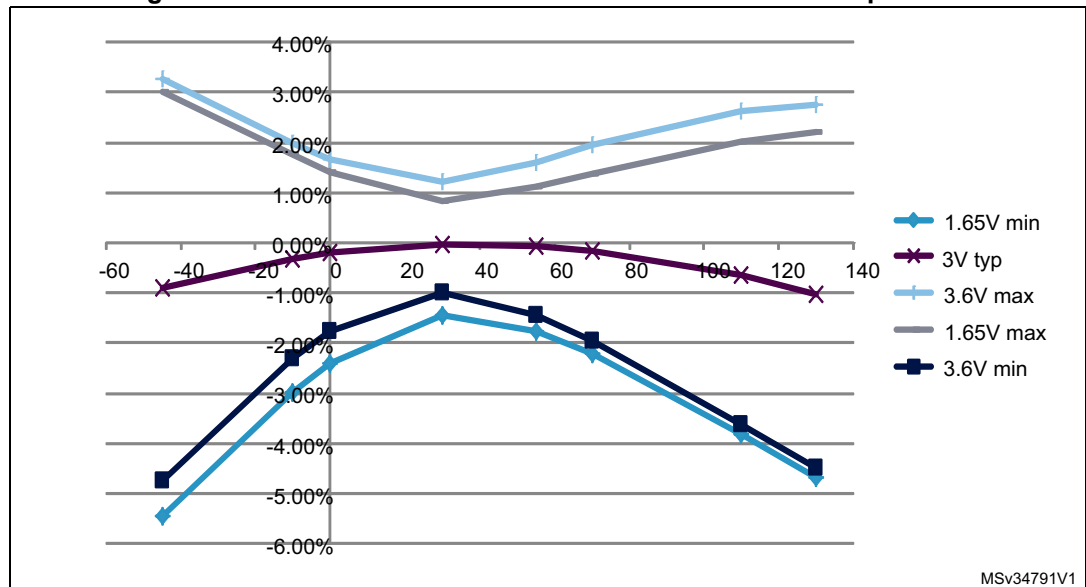
High-speed internal 16 MHz (HSI16) RC oscillator

Table 44. 16 MHz HSI16 oscillator characteristics

| Symbol | Parameter | Conditions | Min | Typ | Max | Unit |
|-----------------------|---|--|-------------------|-----------|------------------|---------------|
| f_{HSI16} | Frequency | $V_{DD} = 3.0\text{ V}$ | - | 16 | - | MHz |
| $TRIM^{(1)(2)}$ | HSI16 user-trimmed resolution | Trimming code is not a multiple of 16 | - | ± 0.4 | 0.7 | % |
| | | Trimming code is a multiple of 16 | - | - | ± 1.5 | % |
| $ACC_{HSI16}^{(2)}$ | Accuracy of the factory-calibrated HSI16 oscillator | $V_{DDA} = 3.0\text{ V}, T_A = 25\text{ }^\circ\text{C}$ | -1 ⁽³⁾ | - | 1 ⁽³⁾ | % |
| | | $V_{DDA} = 3.0\text{ V}, T_A = 0\text{ to }55\text{ }^\circ\text{C}$ | -1.5 | - | 1.5 | % |
| | | $V_{DDA} = 3.0\text{ V}, T_A = -10\text{ to }70\text{ }^\circ\text{C}$ | -2 | - | 2 | % |
| | | $V_{DDA} = 3.0\text{ V}, T_A = -10\text{ to }85\text{ }^\circ\text{C}$ | -2.5 | - | 2 | % |
| | | $V_{DDA} = 3.0\text{ V}, T_A = -10\text{ to }105\text{ }^\circ\text{C}$ | -4 | - | 2 | % |
| | | $V_{DDA} = 1.65\text{ V to }3.6\text{ V}$ $T_A = -40\text{ to }125\text{ }^\circ\text{C}$ | -5.45 | - | 3.25 | % |
| $t_{SU(HSI16)}^{(2)}$ | HSI16 oscillator startup time | - | - | 3.7 | 6 | μs |
| $I_{DD(HSI16)}^{(2)}$ | HSI16 oscillator power consumption | - | - | 100 | 140 | μA |

1. The trimming step differs depending on the trimming code. It is usually negative on the codes which are multiples of 16 (0x00, 0x10, 0x20, 0x30...0xE0).
2. Guaranteed by characterization results, not tested in production.
3. Guaranteed by test in production.

Figure 23. HSI16 minimum and maximum value versus temperature



MSv34791V1

Low-speed internal (LSI) RC oscillator

Table 45. LSI oscillator characteristics

| Symbol | Parameter | Min | Typ | Max | Unit |
|---------------------|--|-----|-----|-----|---------|
| $f_{LSI}^{(1)}$ | LSI frequency | 26 | 38 | 56 | kHz |
| $D_{LSI}^{(2)}$ | LSI oscillator frequency drift $0^{\circ}C \leq T_A \leq 85^{\circ}C$ | -10 | - | 4 | % |
| $t_{su(LSI)}^{(3)}$ | LSI oscillator startup time | - | - | 200 | μs |
| $I_{DD(LSI)}^{(3)}$ | LSI oscillator power consumption | - | 400 | 510 | nA |

1. Guaranteed by test in production.
2. This is a deviation for an individual part, once the initial frequency has been measured.
3. Guaranteed by design, not tested in production.

Multi-speed internal (MSI) RC oscillator

Table 46. MSI oscillator characteristics

| Symbol | Parameter | Condition | Typ | Max | Unit |
|-----------------------|---|-------------|-----------|-----|---------|
| f_{MSI} | Frequency after factory calibration, done at $V_{DD} = 3.3 V$ and $T_A = 25^{\circ}C$ | MSI range 0 | 65.5 | - | kHz |
| | | MSI range 1 | 131 | - | |
| | | MSI range 2 | 262 | - | |
| | | MSI range 3 | 524 | - | MHz |
| | | MSI range 4 | 1.05 | - | |
| | | MSI range 5 | 2.1 | - | |
| | | MSI range 6 | 4.2 | - | |
| ACC_{MSI} | Frequency error after factory calibration | - | ± 0.5 | - | % |
| $D_{TEMP(MSI)}^{(1)}$ | MSI oscillator frequency drift $0^{\circ}C \leq T_A \leq 85^{\circ}C$ | - | ± 3 | - | % |
| $D_{VOLT(MSI)}^{(1)}$ | MSI oscillator frequency drift $1.65 V \leq V_{DD} \leq 3.6 V, T_A = 25^{\circ}C$ | - | - | 2.5 | %/V |
| $I_{DD(MSI)}^{(2)}$ | MSI oscillator power consumption | MSI range 0 | 0.75 | - | μA |
| | | MSI range 1 | 1 | - | |
| | | MSI range 2 | 1.5 | - | |
| | | MSI range 3 | 2.5 | - | |
| | | MSI range 4 | 4.5 | - | |
| | | MSI range 5 | 8 | - | |
| | | MSI range 6 | 15 | - | |

Table 46. MSI oscillator characteristics (continued)

| Symbol | Parameter | Condition | Typ | Max | Unit |
|---------------------------------------|------------------------------------|------------------------------------|-----|-----|------|
| t _{SU(MSI)} | MSI oscillator startup time | MSI range 0 | 30 | - | µs |
| | | MSI range 1 | 20 | - | |
| | | MSI range 2 | 15 | - | |
| | | MSI range 3 | 10 | - | |
| | | MSI range 4 | 6 | - | |
| | | MSI range 5 | 5 | - | |
| | | MSI range 6, Voltage range 1 and 2 | 3.5 | - | |
| t _{STAB(MSI)} ⁽²⁾ | MSI oscillator stabilization time | MSI range 0 | - | 40 | µs |
| | | MSI range 1 | - | 20 | |
| | | MSI range 2 | - | 10 | |
| | | MSI range 3 | - | 4 | |
| | | MSI range 4 | - | 2.5 | |
| | | MSI range 5 | - | 2 | |
| | | MSI range 6, Voltage range 1 and 2 | - | 2 | |
| f _{OVER(MSI)} | MSI oscillator frequency overshoot | Any range to range 5 | - | 4 | MHz |
| | | Any range to range 6 | - | 6 | |

1. This is a deviation for an individual part, once the initial frequency has been measured.
2. Guaranteed by characterization results, not tested in production.

6.3.8 PLL characteristics

The parameters given in [Table 47](#) are derived from tests performed under ambient temperature and V_{DD} supply voltage conditions summarized in [Table 23](#).

Table 47. PLL characteristics

| Symbol | Parameter | Value | | | Unit |
|---------------------|--------------------------------|-------|-----|--------------------|------|
| | | Min | Typ | Max ⁽¹⁾ | |
| f _{PLL_IN} | PLL input clock ⁽²⁾ | 2 | - | 24 | MHz |
| | PLL input clock duty cycle | 45 | - | 55 | % |

Table 47. PLL characteristics (continued)

| Symbol | Parameter | Value | | | Unit |
|------------------------|---|-------|-----|--------------------|------|
| | | Min | Typ | Max ⁽¹⁾ | |
| f _{PLL_OUT} | PLL output clock | 2 | - | 32 | MHz |
| t _{LOCK} | PLL input = 16 MHz PLL VCO = 96 MHz | - | 115 | 160 | μs |
| Jitter | Cycle-to-cycle jitter | - | | ± 600 | ps |
| I _{DDA} (PLL) | Current consumption on V _{DDA} | - | 220 | 450 | μA |
| I _{DD} (PLL) | Current consumption on V _{DD} | - | 120 | 150 | |

1. Guaranteed by characterization results, not tested in production.
2. Take care of using the appropriate multiplier factors so as to have PLL input clock values compatible with the range defined by f_{PLL_OUT}.

6.3.9 Memory characteristics

RAM memory

Table 48. RAM and hardware registers

| Symbol | Parameter | Conditions | Min | Typ | Max | Unit |
|--------|------------------------------------|----------------------|------|-----|-----|------|
| VRM | Data retention mode ⁽¹⁾ | STOP mode (or RESET) | 1.65 | - | - | V |

1. Minimum supply voltage without losing data stored in RAM (in Stop mode or under Reset) or in hardware registers (only in Stop mode).

Flash memory and data EEPROM

Table 49. Flash memory and data EEPROM characteristics

| Symbol | Parameter | Conditions | Min | Typ | Max ⁽¹⁾ | Unit |
|------------|--|--|------|------|--------------------|---------------|
| V_{DD} | Operating voltage Read / Write / Erase | - | 1.65 | - | 3.6 | V |
| t_{prog} | Programming time for word or half-page | Erasing | - | 3.28 | 3.94 | ms |
| | | Programming | - | 3.28 | 3.94 | |
| I_{DD} | Average current during the whole programming / erase operation | $T_A = 25\text{ °C}$, $V_{DD} = 3.6\text{ V}$ | - | 500 | 700 | μA |
| | Maximum current (peak) during the whole programming / erase operation | | - | 1.5 | 2.5 | mA |

1. Guaranteed by design, not tested in production.

Table 50. Flash memory and data EEPROM endurance and retention

| Symbol | Parameter | Conditions | Value | Unit |
|-----------------|---|--|--------------------|---------|
| | | | Min ⁽¹⁾ | |
| $N_{CYC}^{(2)}$ | Cycling (erase / write) Program memory | $T_A = -40\text{ °C}$ to 105 °C | 10 | kcycles |
| | Cycling (erase / write) EEPROM data memory | | 100 | |
| | Cycling (erase / write) Program memory | $T_A = -40\text{ °C}$ to 125 °C | 0.2 | |
| | Cycling (erase / write) EEPROM data memory | | 2 | |
| $t_{RET}^{(2)}$ | Data retention (program memory) after 10 kcycles at $T_A = 85\text{ °C}$ | $T_{RET} = +85\text{ °C}$ | 30 | years |
| | Data retention (EEPROM data memory) after 100 kcycles at $T_A = 85\text{ °C}$ | | 30 | |
| | Data retention (program memory) after 10 kcycles at $T_A = 105\text{ °C}$ | $T_{RET} = +105\text{ °C}$ | 10 | |
| | Data retention (EEPROM data memory) after 100 kcycles at $T_A = 105\text{ °C}$ | | | |
| | Data retention (program memory) after 200 cycles at $T_A = 125\text{ °C}$ | $T_{RET} = +125\text{ °C}$ | | |
| | Data retention (EEPROM data memory) after 2 kcycles at $T_A = 125\text{ °C}$ | | | |

1. Guaranteed by characterization results, not tested in production.

2. Characterization is done according to JEDEC JESD22-A117.

6.3.10 EMC characteristics

Susceptibility tests are performed on a sample basis during device characterization.

Functional EMS (electromagnetic susceptibility)

While a simple application is executed on the device (toggling 2 LEDs through I/O ports), the device is stressed by two electromagnetic events until a failure occurs. The failure is indicated by the LEDs:

- **Electrostatic discharge (ESD)** (positive and negative) is applied to all device pins until a functional disturbance occurs. This test is compliant with the IEC 61000-4-2 standard.
- **FTB: A Burst of Fast Transient voltage** (positive and negative) is applied to V_{DD} and V_{SS} through a 100 pF capacitor, until a functional disturbance occurs. This test is compliant with the IEC 61000-4-4 standard.

A device reset allows normal operations to be resumed.

The test results are given in [Table 51](#). They are based on the EMS levels and classes defined in application note AN1709.

Table 51. EMS characteristics

| Symbol | Parameter | Conditions | Level/Class |
|------------|---|---|-------------|
| V_{FESD} | Voltage limits to be applied on any I/O pin to induce a functional disturbance | $V_{DD} = 3.3\text{ V}$, LQFP100, $T_A = +25\text{ }^\circ\text{C}$, $f_{HCLK} = 32\text{ MHz}$ conforms to IEC 61000-4-2 | 2B |
| V_{EFTB} | Fast transient voltage burst limits to be applied through 100 pF on V_{DD} and V_{SS} pins to induce a functional disturbance | $V_{DD} = 3.3\text{ V}$, LQFP100, $T_A = +25\text{ }^\circ\text{C}$, $f_{HCLK} = 32\text{ MHz}$ conforms to IEC 61000-4-4 | 4A |

Designing hardened software to avoid noise problems

EMC characterization and optimization are performed at component level with a typical application environment and simplified MCU software. It should be noted that good EMC performance is highly dependent on the user application and the software in particular.

Therefore it is recommended that the user applies EMC software optimization and prequalification tests in relation with the EMC level requested for his application.

Software recommendations

The software flowchart must include the management of runaway conditions such as:

- Corrupted program counter
- Unexpected reset
- Critical data corruption (control registers...)

Prequalification trials

Most of the common failures (unexpected reset and program counter corruption) can be reproduced by manually forcing a low state on the NRST pin or the oscillator pins for 1 second.

To complete these trials, ESD stress can be applied directly on the device, over the range of specification values. When unexpected behavior is detected, the software can be hardened to prevent unrecoverable errors occurring (see application note AN1015).

Electromagnetic Interference (EMI)

The electromagnetic field emitted by the device are monitored while a simple application is executed (toggling 2 LEDs through the I/O ports). This emission test is compliant with IEC 61967-2 standard which specifies the test board and the pin loading.

Table 52. EMI characteristics

| Symbol | Parameter | Conditions | Monitored frequency band | Max vs. frequency range | | | Unit |
|------------------|------------|---|--------------------------|-------------------------|------------------------|------------------------|------|
| | | | | 4 MHz voltage range 3 | 16 MHz voltage range 2 | 32 MHz voltage range 1 | |
| S _{EMI} | Peak level | V _{DD} = 3.3 V, T _A = 25 °C, LQFP100 package compliant with IEC 61967-2 | 0.1 to 30 MHz | 3 | -6 | -5 | dBµV |
| | | | 30 to 130 MHz | 18 | 4 | -7 | |
| | | | 130 MHz to 1GHz | 15 | 5 | -7 | |
| | | | SAE EMI Level | 2.5 | 2 | 1 | - |

6.3.11 Electrical sensitivity characteristics

Based on three different tests (ESD, LU) using specific measurement methods, the device is stressed in order to determine its performance in terms of electrical sensitivity.

Electrostatic discharge (ESD)

Electrostatic discharges (a positive then a negative pulse separated by 1 second) are applied to the pins of each sample according to each pin combination. The sample size depends on the number of supply pins in the device (3 parts × (n+1) supply pins). This test conforms to the ANSI/JEDEC standard.

Table 53. ESD absolute maximum ratings

| Symbol | Ratings | Conditions | Class | Maximum value ⁽¹⁾ | Unit |
|-----------------------|---|---|-------|------------------------------|------|
| V _{ESD(HBM)} | Electrostatic discharge voltage (human body model) | T _A = +25 °C, conforming to ANSI/JEDEC JS-001 | 2 | 2000 | V |
| V _{ESD(CDM)} | Electrostatic discharge voltage (charge device model) | T _A = +25 °C, conforming to ANSI/ESD STM5.3.1. | C4 | 500 | |

1. Guaranteed by characterization results, not tested in production.



Static latch-up

Two complementary static tests are required on six parts to assess the latch-up performance:

- A supply overvoltage is applied to each power supply pin
- A current injection is applied to each input, output and configurable I/O pin

These tests are compliant with EIA/JESD 78A IC latch-up standard.

Table 54. Electrical sensitivities

| Symbol | Parameter | Conditions | Class |
|--------|-----------------------|--|------------|
| LU | Static latch-up class | T _A = +125 °C conforming to JESD78A | II level A |

6.3.12 I/O current injection characteristics

As a general rule, current injection to the I/O pins, due to external voltage below V_{SS} or above V_{DD} (for standard pins) should be avoided during normal product operation. However, in order to give an indication of the robustness of the microcontroller in cases when abnormal injection accidentally happens, susceptibility tests are performed on a sample basis during device characterization.

Functional susceptibility to I/O current injection

While a simple application is executed on the device, the device is stressed by injecting current into the I/O pins programmed in floating input mode. While current is injected into the I/O pin, one at a time, the device is checked for functional failures.

The failure is indicated by an out of range parameter: ADC error above a certain limit (higher than 5 LSB TUE), out of conventional limits of induced leakage current on adjacent pins (out of -5 µA/+0 µA range), or other functional failure (for example reset occurrence oscillator frequency deviation).

The test results are given in the [Table 55](#).

Table 55. I/O current injection susceptibility

| Symbol | Description | Functional susceptibility | | Unit |
|------------------|-----------------------------------|---------------------------|--------------------|------|
| | | Negative injection | Positive injection | |
| I _{INJ} | Injected current on BOOT0 | -0 | NA | mA |
| | Injected current on all FT pins | -5 ⁽¹⁾ | NA | |
| | Injected current on any other pin | -5 ⁽¹⁾ | +5 | |

1. It is recommended to add a Schottky diode (pin to ground) to analog pins which may potentially inject negative currents.

6.3.13 I/O port characteristics

General input/output characteristics

Unless otherwise specified, the parameters given in [Table 56](#) are derived from tests performed under the conditions summarized in [Table 23](#). All I/Os are CMOS and TTL compliant.

Table 56. I/O static characteristics

| Symbol | Parameter | Conditions | Min | Typ | Max | Unit |
|-----------|---|---|--------------|---------------------|--------------------|------------|
| V_{IL} | Input low level voltage | TC, FT, FTf, RST I/Os | - | - | $0.3V_{DD}$ | V |
| | | BOOT0 pin | - | - | $0.14V_{DD}^{(1)}$ | |
| V_{IH} | Input high level voltage | All I/Os | $0.7 V_{DD}$ | - | - | |
| V_{hys} | I/O Schmitt trigger voltage hysteresis ⁽²⁾ | Standard I/Os | - | $10\% V_{DD}^{(3)}$ | - | |
| | | BOOT0 pin | - | 0.01 | - | |
| I_{ikg} | Input leakage current ⁽⁴⁾ | $V_{SS} \leq V_{IN} \leq V_{DD}$ I/Os with analog switches | - | - | ± 50 | pA |
| | | $V_{SS} \leq V_{IN} \leq V_{DD}$ Standard I/Os | - | - | ± 50 | |
| | | FT I/O $V_{DD} \leq V_{IN} \leq 5 V$ | - | - | ± 10 | |
| R_{PU} | Weak pull-up equivalent resistor ⁽⁵⁾ | $V_{IN} = V_{SS}$ | 30 | 45 | 60 | k Ω |
| R_{PD} | Weak pull-down equivalent resistor ⁽⁵⁾ | $V_{IN} = V_{DD}$ | 30 | 45 | 60 | k Ω |
| C_{IO} | I/O pin capacitance | - | - | 5 | - | pF |

1. Guaranteed by characterization, not tested in production
2. Hysteresis voltage between Schmitt trigger switching levels. Guaranteed by characterization results, not tested in production.
3. With a minimum of 200 mV. Guaranteed by characterization results, not tested in production.
4. The max. value may be exceeded if negative current is injected on adjacent pins.
5. Pull-up and pull-down resistors are designed with a true resistance in series with a switchable PMOS/NMOS. This MOS/NMOS contribution to the series resistance is minimum (~10% order).

Figure 24. V_{IH}/V_{IL} versus V_{DD} (CMOS I/Os)

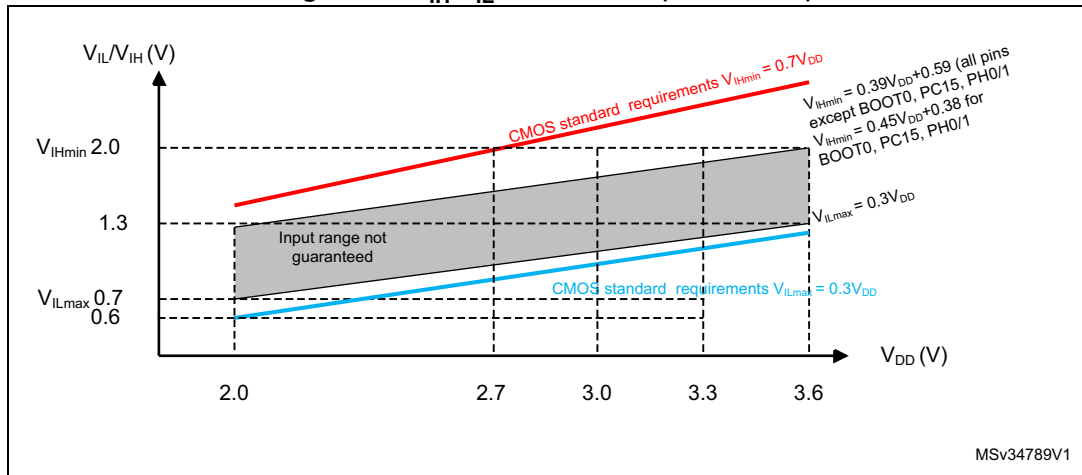
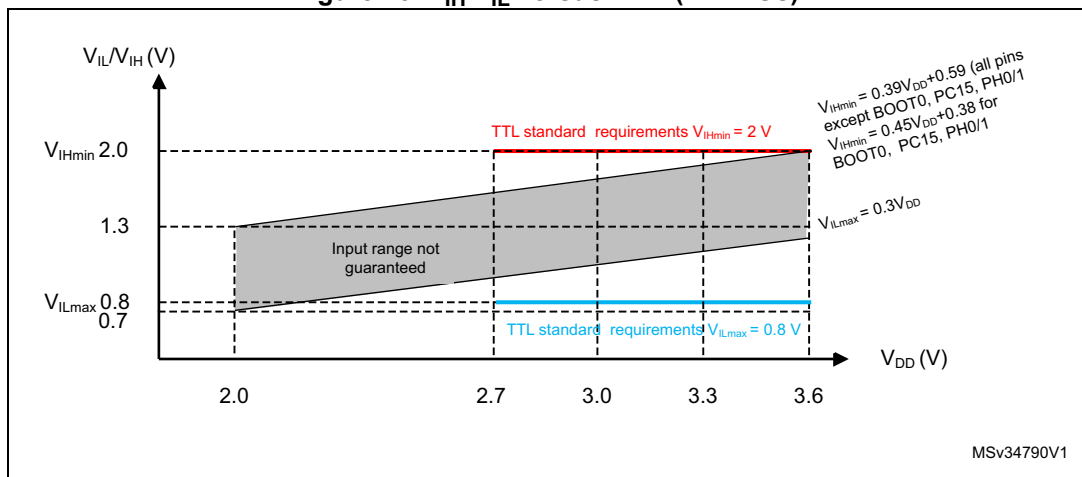


Figure 25. V_{IH}/V_{IL} versus V_{DD} (TTL I/Os)



Output driving current

The GPIOs (general purpose input/outputs) can sink or source up to ± 8 mA, and sink or source up to ± 15 mA with the non-standard V_{OL}/V_{OH} specifications given in [Table 57](#).

In the user application, the number of I/O pins which can drive current must be limited to respect the absolute maximum rating specified in [Section 6.2](#):

- The sum of the currents sourced by all the I/Os on V_{DD} , plus the maximum Run consumption of the MCU sourced on V_{DD} , cannot exceed the absolute maximum rating $I_{VDD(\Sigma)}$ (see [Table 21](#)).
- The sum of the currents sunk by all the I/Os on V_{SS} plus the maximum Run consumption of the MCU sunk on V_{SS} cannot exceed the absolute maximum rating $I_{VSS(\Sigma)}$ (see [Table 21](#)).

Output voltage levels

Unless otherwise specified, the parameters given in [Table 57](#) are derived from tests performed under ambient temperature and V_{DD} supply voltage conditions summarized in [Table 23](#). All I/Os are CMOS and TTL compliant.

Table 57. Output voltage characteristics

| Symbol | Parameter | Conditions | Min | Max | Unit |
|----------------------|---|--|---------------|------|------|
| $V_{OL}^{(1)}$ | Output low level voltage for an I/O pin | CMOS port ⁽²⁾ , $I_{IO} = +8 \text{ mA}$ $2.7 \text{ V} \leq V_{DD} \leq 3.6 \text{ V}$ | - | 0.4 | V |
| $V_{OH}^{(3)}$ | Output high level voltage for an I/O pin | | $V_{DD}-0.4$ | - | |
| $V_{OL}^{(1)}$ | Output low level voltage for an I/O pin | TTL port ⁽²⁾ , $I_{IO} = +8 \text{ mA}$ $2.7 \text{ V} \leq V_{DD} \leq 3.6 \text{ V}$ | - | 0.4 | |
| $V_{OH}^{(3)(4)}$ | Output high level voltage for an I/O pin | TTL port ⁽²⁾ , $I_{IO} = -6 \text{ mA}$ $2.7 \text{ V} \leq V_{DD} \leq 3.6 \text{ V}$ | 2.4 | - | |
| $V_{OL}^{(1)(4)}$ | Output low level voltage for an I/O pin | $I_{IO} = +15 \text{ mA}$ $2.7 \text{ V} \leq V_{DD} \leq 3.6 \text{ V}$ | - | 1.3 | |
| $V_{OH}^{(3)(4)}$ | Output high level voltage for an I/O pin | $I_{IO} = -15 \text{ mA}$ $2.7 \text{ V} \leq V_{DD} \leq 3.6 \text{ V}$ | $V_{DD}-1.3$ | - | |
| $V_{OL}^{(1)(4)}$ | Output low level voltage for an I/O pin | $I_{IO} = +4 \text{ mA}$ $1.65 \text{ V} \leq V_{DD} < 3.6 \text{ V}$ | - | 0.45 | |
| $V_{OH}^{(3)(4)}$ | Output high level voltage for an I/O pin | $I_{IO} = -4 \text{ mA}$ $1.65 \text{ V} \leq V_{DD} \leq 3.6 \text{ V}$ | $V_{DD}-0.45$ | - | |
| $V_{OLFM+}^{(1)(4)}$ | Output low level voltage for an FTf I/O pin in Fm+ mode | $I_{IO} = 20 \text{ mA}$ $2.7 \text{ V} \leq V_{DD} \leq 3.6 \text{ V}$ | - | 0.4 | |
| | | $I_{IO} = 10 \text{ mA}$ $1.65 \text{ V} \leq V_{DD} \leq 3.6 \text{ V}$ | - | 0.4 | |

- The I_{IO} current sunk by the device must always respect the absolute maximum rating specified in [Table 21](#). The sum of the currents sunk by all the I/Os (I/O ports and control pins) must always be respected and must not exceed $\Sigma I_{IO(PIN)}$.
- TTL and CMOS outputs are compatible with JEDEC standards JESD36 and JESD52.
- The I_{IO} current sourced by the device must always respect the absolute maximum rating specified in [Table 21](#). The sum of the currents sourced by all the I/Os (I/O ports and control pins) must always be respected and must not exceed $\Sigma I_{IO(PIN)}$.
- Guaranteed by characterization results, not tested in production.

Input/output AC characteristics

The definition and values of input/output AC characteristics are given in [Figure 26](#) and [Table 58](#), respectively.

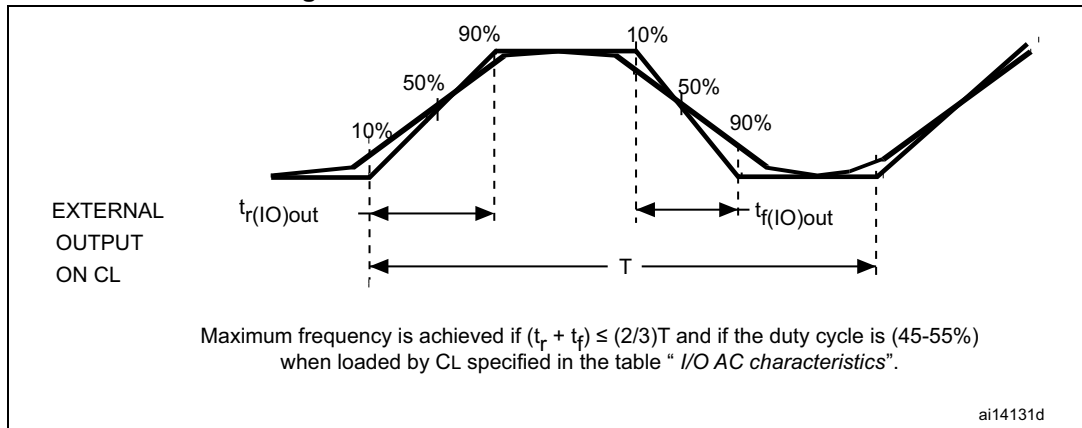
Unless otherwise specified, the parameters given in [Table 58](#) are derived from tests performed under ambient temperature and V_{DD} supply voltage conditions summarized in [Table 23](#).

Table 58. I/O AC characteristics⁽¹⁾

| OSPEEDRx [1:0] bit value ⁽¹⁾ | Symbol | Parameter | Conditions | Min | Max ⁽²⁾ | Unit |
|---|--|---|--|-----|--------------------|------|
| 00 | $f_{\max(\text{IO})\text{out}}$ | Maximum frequency ⁽³⁾ | $C_L = 50 \text{ pF}, V_{DD} = 2.7 \text{ V to } 3.6 \text{ V}$ | - | 400 | kHz |
| | | | $C_L = 50 \text{ pF}, V_{DD} = 1.65 \text{ V to } 2.7 \text{ V}$ | - | 100 | |
| | $t_{f(\text{IO})\text{out}}$ $t_{r(\text{IO})\text{out}}$ | Output rise and fall time | $C_L = 50 \text{ pF}, V_{DD} = 2.7 \text{ V to } 3.6 \text{ V}$ | - | 125 | ns |
| | | | $C_L = 50 \text{ pF}, V_{DD} = 1.65 \text{ V to } 2.7 \text{ V}$ | - | 320 | |
| 01 | $f_{\max(\text{IO})\text{out}}$ | Maximum frequency ⁽³⁾ | $C_L = 50 \text{ pF}, V_{DD} = 2.7 \text{ V to } 3.6 \text{ V}$ | - | 2 | MHz |
| | | | $C_L = 50 \text{ pF}, V_{DD} = 1.65 \text{ V to } 2.7 \text{ V}$ | - | 0.6 | |
| | $t_{f(\text{IO})\text{out}}$ $t_{r(\text{IO})\text{out}}$ | Output rise and fall time | $C_L = 50 \text{ pF}, V_{DD} = 2.7 \text{ V to } 3.6 \text{ V}$ | - | 30 | ns |
| | | | $C_L = 50 \text{ pF}, V_{DD} = 1.65 \text{ V to } 2.7 \text{ V}$ | - | 65 | |
| 10 | $F_{\max(\text{IO})\text{out}}$ | Maximum frequency ⁽³⁾ | $C_L = 50 \text{ pF}, V_{DD} = 2.7 \text{ V to } 3.6 \text{ V}$ | - | 10 | MHz |
| | | | $C_L = 50 \text{ pF}, V_{DD} = 1.65 \text{ V to } 2.7 \text{ V}$ | - | 2 | |
| | $t_{f(\text{IO})\text{out}}$ $t_{r(\text{IO})\text{out}}$ | Output rise and fall time | $C_L = 50 \text{ pF}, V_{DD} = 2.7 \text{ V to } 3.6 \text{ V}$ | - | 13 | ns |
| | | | $C_L = 50 \text{ pF}, V_{DD} = 1.65 \text{ V to } 2.7 \text{ V}$ | - | 28 | |
| 11 | $F_{\max(\text{IO})\text{out}}$ | Maximum frequency ⁽³⁾ | $C_L = 30 \text{ pF}, V_{DD} = 2.7 \text{ V to } 3.6 \text{ V}$ | - | 35 | MHz |
| | | | $C_L = 50 \text{ pF}, V_{DD} = 1.65 \text{ V to } 2.7 \text{ V}$ | - | 10 | |
| | $t_{f(\text{IO})\text{out}}$ $t_{r(\text{IO})\text{out}}$ | Output rise and fall time | $C_L = 30 \text{ pF}, V_{DD} = 2.7 \text{ V to } 3.6 \text{ V}$ | - | 6 | ns |
| | | | $C_L = 50 \text{ pF}, V_{DD} = 1.65 \text{ V to } 2.7 \text{ V}$ | - | 17 | |
| - | $t_{\text{EXTI}pw}$ | Pulse width of external signals detected by the EXTI controller | - | 8 | - | ns |

1. The I/O speed is configured using the OSPEEDRx[1:0] bits. Refer to the line reference manual for a description of GPIO Port configuration register.
2. Guaranteed by design. Not tested in production.
3. The maximum frequency is defined in [Figure 26](#).

Figure 26. I/O AC characteristics definition



6.3.14 NRST pin characteristics

The NRST pin input driver uses CMOS technology. It is connected to a permanent pull-up resistor, R_{PU} , except when it is internally driven low (see [Table 59](#)).

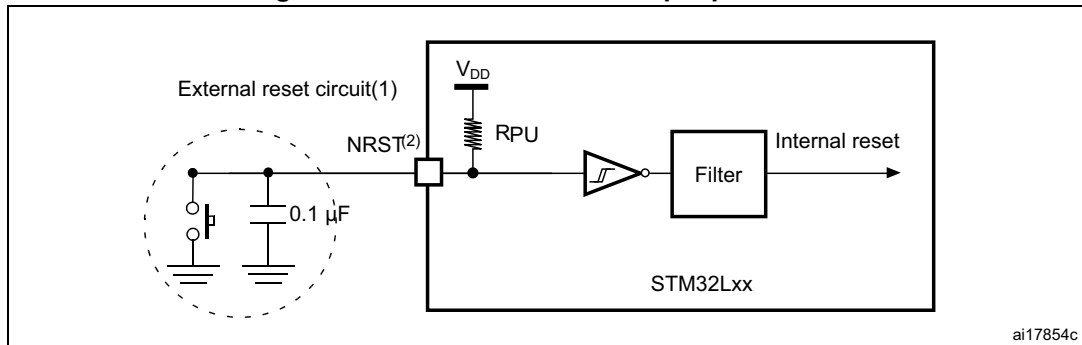
Unless otherwise specified, the parameters given in [Table 59](#) are derived from tests performed under ambient temperature and V_{DD} supply voltage conditions summarized in [Table 23](#).

Table 59. NRST pin characteristics

| Symbol | Parameter | Conditions | Min | Typ | Max | Unit |
|-----------------------|---|---|----------|--------------------|----------|------------|
| $V_{IL(NRST)}^{(1)}$ | NRST input low level voltage | - | V_{SS} | - | 0.8 | V |
| $V_{IH(NRST)}^{(1)}$ | NRST input high level voltage | - | 1.4 | - | V_{DD} | |
| $V_{OL(NRST)}^{(1)}$ | NRST output low level voltage | $I_{OL} = 2\text{ mA}$ $2.7\text{ V} < V_{DD} < 3.6\text{ V}$ | - | - | 0.4 | |
| | | $I_{OL} = 1.5\text{ mA}$ $1.65\text{ V} < V_{DD} < 2.7\text{ V}$ | - | - | | |
| $V_{hys(NRST)}^{(1)}$ | NRST Schmitt trigger voltage hysteresis | - | - | $10\%V_{DD}^{(2)}$ | - | mV |
| R_{PU} | Weak pull-up equivalent resistor ⁽³⁾ | $V_{IN} = V_{SS}$ | 30 | 45 | 60 | k Ω |
| $V_{F(NRST)}^{(1)}$ | NRST input filtered pulse | - | - | - | 50 | ns |
| $V_{NF(NRST)}^{(1)}$ | NRST input not filtered pulse | - | 350 | - | - | ns |

1. Guaranteed by design, not tested in production.
2. 200 mV minimum value
3. The pull-up is designed with a true resistance in series with a switchable PMOS. This PMOS contribution to the series resistance is around 10%.

Figure 27. Recommended NRST pin protection



1. The reset network protects the device against parasitic resets.
2. The user must ensure that the level on the NRST pin can go below the $V_{IL(NRST)}$ max level specified in [Table 59](#). Otherwise the reset will not be taken into account by the device.

6.3.15 12-bit ADC characteristics

Unless otherwise specified, the parameters given in [Table 60](#) are preliminary values derived from tests performed under ambient temperature, f_{PCLK} frequency and V_{DDA} supply voltage conditions summarized in [Table 23: General operating conditions](#).

Note: It is recommended to perform a calibration after each power-up.

Table 60. ADC characteristics

| Symbol | Parameter | Conditions | Min | Typ | Max | Unit |
|------------------|--|---|------|-----|-----------|-------------|
| V_{DDA} | Analog supply voltage for ADC on | | 1.65 | - | 3.6 | V |
| $I_{DDA(ADC)}$ | Current consumption of the ADC on V_{DDA} and V_{REF+} | 1.14 Msps | - | 200 | - | μA |
| | | 10 ksps | - | 40 | - | |
| | Current consumption of the ADC on $V_{DD}^{(1)}$ | 1.14 Msps | - | 70 | - | |
| | | 10 ksps | - | 1 | - | |
| f_{ADC} | ADC clock frequency | Voltage scaling Range 1 | 0.14 | - | 16 | MHz |
| | | Voltage scaling Range 2 | 0.14 | - | 8 | |
| | | Voltage scaling Range 3 | 0.14 | - | 4 | |
| $f_S^{(2)}$ | Sampling rate | | 0.05 | - | 1.14 | MHz |
| $f_{TRIG}^{(2)}$ | External trigger frequency | $f_{ADC} = 16$ MHz | - | - | 941 | kHz |
| | | | - | - | 17 | $1/f_{ADC}$ |
| V_{AIN} | Conversion voltage range | | 0 | - | V_{DDA} | V |
| $R_{AIN}^{(2)}$ | External input impedance | See Equation 1 and Table 61 for details | - | - | 50 | k Ω |
| $R_{ADC}^{(2)}$ | Sampling switch resistance | | - | - | 1 | k Ω |
| $C_{ADC}^{(2)}$ | Internal sample and hold capacitor | | - | - | 8 | pF |

Table 60. ADC characteristics (continued)

| Symbol | Parameter | Conditions | Min | Typ | Max | Unit |
|------------------|---|---|---|-----|--------------------------------------|------------------|
| $t_{CAL}^{(2)}$ | Calibration time | $f_{ADC} = 16 \text{ MHz}$ | 5.2 | | | μs |
| | | | 83 | | | $1/f_{ADC}$ |
| $W_{LATENCY}$ | ADC_DR register write latency | ADC clock = HSI16 | 1.5 ADC cycles + 2 f_{PCLK} cycles | - | 1.5 ADC cycles + 3 f_{PCLK} cycles | - |
| | | ADC clock = PCLK/2 | - | 4.5 | - | f_{PCLK} cycle |
| | | ADC clock = PCLK/4 | - | 8.5 | - | f_{PCLK} cycle |
| $t_{latr}^{(2)}$ | Trigger conversion latency | $f_{ADC} = f_{PCLK}/2 = 16 \text{ MHz}$ | 0.266 | | | μs |
| | | $f_{ADC} = f_{PCLK}/2$ | 8.5 | | | $1/f_{PCLK}$ |
| | | $f_{ADC} = f_{PCLK}/4 = 8 \text{ MHz}$ | 0.516 | | | μs |
| | | $f_{ADC} = f_{PCLK}/4$ | 16.5 | | | $1/f_{PCLK}$ |
| | | $f_{ADC} = f_{HSI16} = 16 \text{ MHz}$ | 0.252 | - | 0.260 | μs |
| $Jitter_{ADC}$ | ADC jitter on trigger conversion | $f_{ADC} = f_{HSI16}$ | - | 1 | - | $1/f_{HSI16}$ |
| $t_S^{(2)}$ | Sampling time | $f_{ADC} = 16 \text{ MHz}$ | 0.093 | - | 15 | μs |
| | | | 1.5 | - | 239.5 | $1/f_{ADC}$ |
| $t_{STAB}^{(2)}$ | Power-up time | | 0 | 0 | 1 | μs |
| $t_{ConV}^{(2)}$ | Total conversion time (including sampling time) | $f_{ADC} = 16 \text{ MHz}$ | 1 | | 15.75 | μs |
| | | | 14 to 252 (t_S for sampling + 12.5 for successive approximation) | | | $1/f_{ADC}$ |

1. A current consumption proportional to the APB clock frequency has to be added (see [Table 37: Peripheral current consumption in run or Sleep mode](#)).
2. Guaranteed by design, not tested in production.

Equation 1: R_{AIN} max formula

$$R_{AIN} < \frac{T_S}{f_{ADC} \times C_{ADC} \times \ln(2^{N+2})} - R_{ADC}$$

The formula above ([Equation 1](#)) is used to determine the maximum external impedance allowed for an error below 1/4 of LSB. Here N = 12 (from 12-bit resolution).



Table 61. R_{AIN} max for $f_{ADC} = 14$ MHz

| T_s (cycles) | t_s (μ s) | R_{AIN} max ($k\Omega$) ⁽¹⁾ |
|----------------|------------------|--|
| 1.5 | 0.11 | 0.4 |
| 7.5 | 0.54 | 5.9 |
| 13.5 | 0.96 | 11.4 |
| 28.5 | 2.04 | 25.2 |
| 41.5 | 2.96 | 37.2 |
| 55.5 | 3.96 | 50 |
| 71.5 | 5.11 | NA |
| 239.5 | 17.1 | NA |

1. Guaranteed by design, not tested in production.

Table 62. ADC accuracy⁽¹⁾⁽²⁾⁽³⁾

| Symbol | Parameter | Conditions | Min | Typ | Max | Unit | |
|--------|--|--|--|------|------|------|------|
| ET | Total unadjusted error | $1.65\text{ V} < V_{DDA} = V_{REF+} < 3.6\text{ V}$, range 1/2/3 | - | 2 | 4 | LSB | |
| EO | Offset error | | - | 1 | 2.5 | | |
| EG | Gain error | | - | 1 | 2 | | |
| EL | Integral linearity error | | - | 1.5 | 2.5 | | |
| ED | Differential linearity error | | - | 1 | 1.5 | | |
| ENOB | Effective number of bits | | $1.65\text{ V} < V_{REF+} < V_{DDA} < 3.6\text{ V}$, range 1/2/3 | 10.2 | 11 | - | bits |
| | Effective number of bits (16-bit mode oversampling with ratio =256) ⁽⁴⁾ | | | 11.3 | 12.1 | - | |
| SINAD | Signal-to-noise distortion | | | 63 | 69 | - | dB |
| SNR | Signal-to-noise ratio | | | 63 | 69 | - | |
| | Signal-to-noise ratio (16-bit mode oversampling with ratio =256) ⁽⁴⁾ | | | 70 | 76 | - | |
| THD | Total harmonic distortion | - | | -85 | -73 | | |
| ET | Total unadjusted error | $1.65\text{ V} < V_{REF+} < V_{DDA} < 3.6\text{ V}$, range 1/2/3 | | - | 2 | 5 | LSB |
| EO | Offset error | | | - | 1 | 2.5 | |
| EG | Gain error | | | - | 1 | 2 | |
| EL | Integral linearity error | | | - | 1.5 | 3 | |
| ED | Differential linearity error | | - | 1 | 2 | | |
| ENOB | Effective number of bits | | $1.65\text{ V} < V_{REF+} < V_{DDA} < 3.6\text{ V}$, range 1/2/3 | 10.0 | 11.0 | - | bits |
| SINAD | Signal-to-noise distortion | | | 62 | 69 | - | |
| SNR | Signal-to-noise ratio | | | 61 | 69 | - | dB |
| THD | Total harmonic distortion | | | - | -85 | -65 | |

1. ADC DC accuracy values are measured after internal calibration.

2. ADC Accuracy vs. Negative Injection Current: Injecting negative current on any of the standard (non-robust) analog input pins should be avoided as this significantly reduces the accuracy of the conversion being performed on another analog input. It is recommended to add a Schottky diode (pin to ground) to standard analog pins which may potentially inject negative current. Any positive injection current within the limits specified for $I_{INJ(PIN)}$ and $\Sigma I_{INJ(PIN)}$ in [Section 6.3.12](#) does not affect the ADC accuracy.
3. Better performance may be achieved in restricted V_{DDA} , frequency and temperature ranges.
4. This number is obtained by the test board without additional noise, resulting in non-optimized value for oversampling mode.

Figure 28. ADC accuracy characteristics

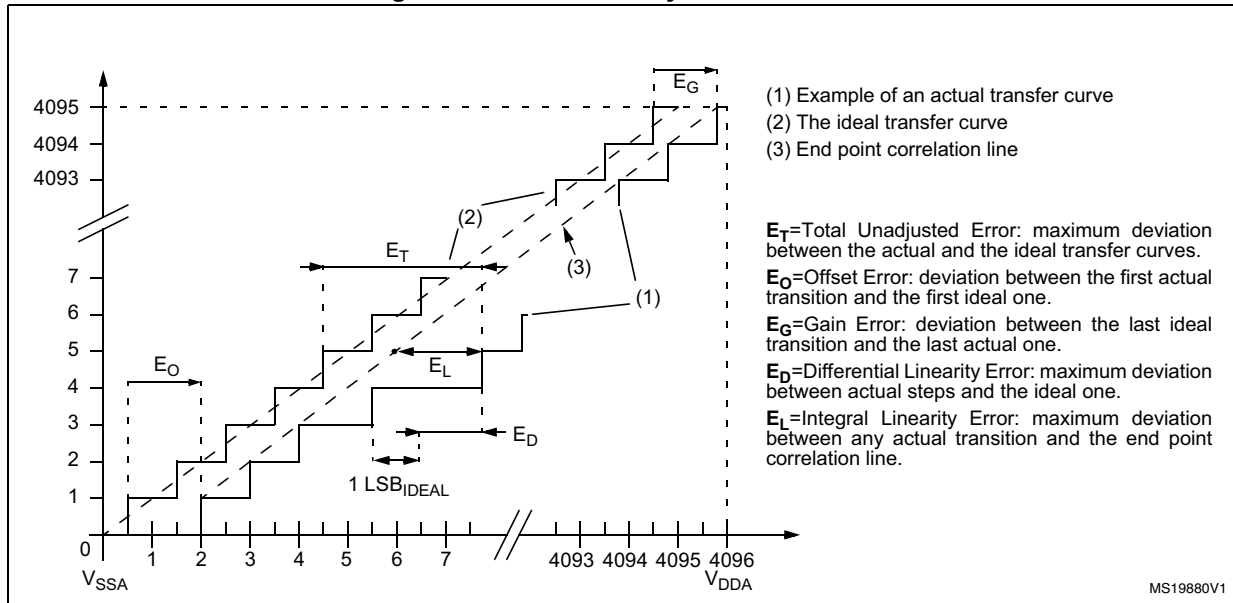
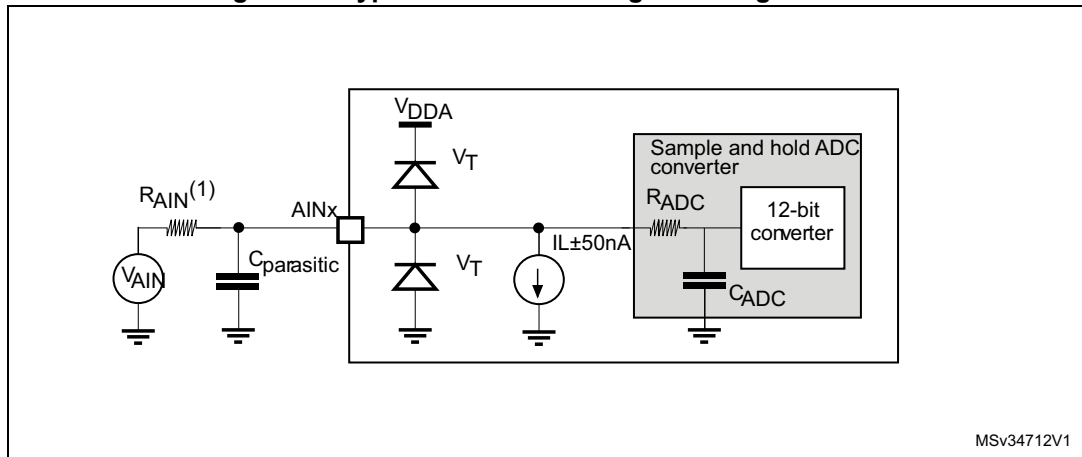


Figure 29. Typical connection diagram using the ADC



1. Refer to [Table 60: ADC characteristics](#) for the values of R_{AIN} , R_{ADC} and C_{ADC} .
2. $C_{parasitic}$ represents the capacitance of the PCB (dependent on soldering and PCB layout quality) plus the pad capacitance (roughly 7 pF). A high $C_{parasitic}$ value will downgrade conversion accuracy. To remedy this, f_{ADC} should be reduced.

General PCB design guidelines

Power supply decoupling should be performed as shown in [Figure 30](#) or [Figure 31](#), depending on whether V_{REF+} is connected to V_{DDA} or not. The 10 nF capacitors should be ceramic (good quality). They should be placed as close as possible to the chip.

Figure 30. Power supply and reference decoupling (V_{REF+} not connected to V_{DDA})

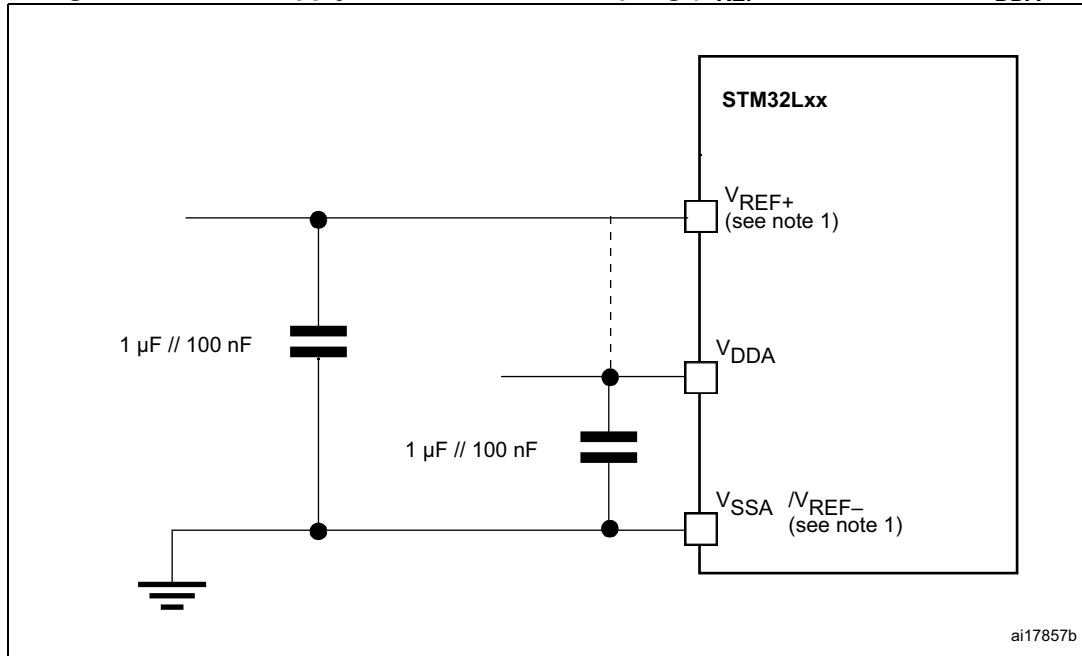
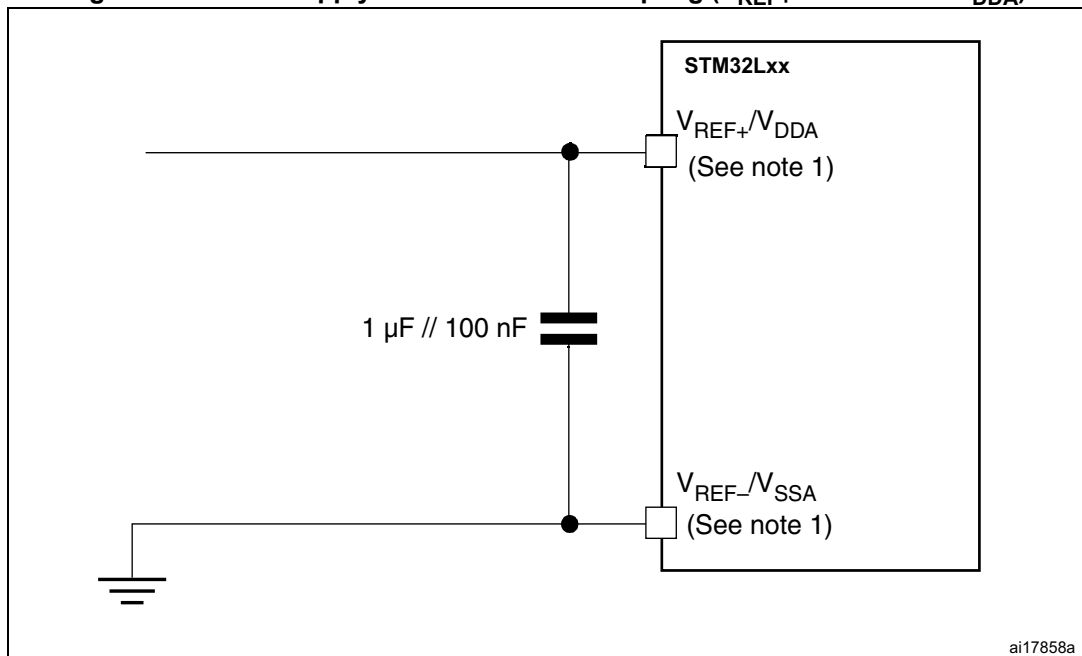


Figure 31. Power supply and reference decoupling (V_{REF+} connected to V_{DDA})



6.3.16 Temperature sensor characteristics

Table 63. Temperature sensor calibration values

| Calibration value name | Description | Memory address |
|------------------------|--|---------------------------|
| TS_CAL1 | TS ADC raw data acquired at temperature of 30 °C, $V_{DDA} = 3\text{ V}$ | 0x1FF8 007A - 0x1FF8 007B |
| TS_CAL2 | TS ADC raw data acquired at temperature of 130 °C $V_{DDA} = 3\text{ V}$ | 0x1FF8 007E - 0x1FF8 007F |

Table 64. Temperature sensor characteristics

| Symbol | Parameter | Min | Typ | Max | Unit |
|--------------------------|--|------|---------|---------|-------|
| $T_L^{(1)}$ | V_{SENSE} linearity with temperature | - | ± 1 | ± 2 | °C |
| Avg_Slope ⁽¹⁾ | Average slope | 1.48 | 1.61 | 1.75 | mV/°C |
| V_{130} | Voltage at 130°C $\pm 5^\circ\text{C}^{(2)}$ | 640 | 670 | 700 | mV |
| $I_{DDA(TEMP)}^{(3)}$ | Current consumption | - | 3.4 | 6 | µA |
| $t_{START}^{(3)}$ | Startup time | - | - | 10 | µs |
| $T_{S_temp}^{(4)(3)}$ | ADC sampling time when reading the temperature | 10 | - | - | |

1. Guaranteed by characterization results, not tested in production.
2. Measured at $V_{DD} = 3\text{ V} \pm 10\text{ mV}$. V_{130} ADC conversion result is stored in the TS_CAL2 byte.
3. Guaranteed by design, not tested in production.
4. Shortest sampling time can be determined in the application by multiple iterations.

6.3.17 Comparators

Table 65. Comparator 1 characteristics

| Symbol | Parameter | Conditions | Min ⁽¹⁾ | Typ | Max ⁽¹⁾ | Unit |
|--------------|----------------------------------|------------|--------------------|---------|--------------------|------|
| V_{DDA} | Analog supply voltage | - | 1.65 | | 3.6 | V |
| R_{400K} | R_{400K} value | - | - | 400 | - | kΩ |
| R_{10K} | R_{10K} value | - | - | 10 | - | |
| V_{IN} | Comparator 1 input voltage range | - | 0.6 | - | V_{DDA} | V |
| t_{START} | Comparator startup time | - | - | 7 | 10 | µs |
| t_d | Propagation delay ⁽²⁾ | - | - | 3 | 10 | |
| V_{offset} | Comparator offset | - | - | ± 3 | ± 10 | mV |

Table 65. Comparator 1 characteristics (continued)

| Symbol | Parameter | Conditions | Min ⁽¹⁾ | Typ | Max ⁽¹⁾ | Unit |
|------------------|--|--|--------------------|-----|--------------------|-----------|
| dV_{offset}/dt | Comparator offset variation in worst voltage stress conditions | $V_{DDA} = 3.6\text{ V}$ $V_{IN+} = 0\text{ V}$ $V_{IN-} = V_{REFINT}$ $T_A = 25\text{ }^\circ\text{C}$ | 0 | 1.5 | 10 | mV/1000 h |
| I_{COMP1} | Current consumption ⁽³⁾ | - | - | 160 | 260 | nA |

1. Guaranteed by characterization, not tested in production.
2. The delay is characterized for 100 mV input step with 10 mV overdrive on the inverting input, the non-inverting input set to the reference.
3. Comparator consumption only. Internal reference voltage not included.

Table 66. Comparator 2 characteristics

| Symbol | Parameter | Conditions | Min | Typ | Max ⁽¹⁾ | Unit |
|-----------------|---|--|------|---------|--------------------|-----------------------|
| V_{DDA} | Analog supply voltage | - | 1.65 | - | 3.6 | V |
| V_{IN} | Comparator 2 input voltage range | - | 0 | - | V_{DDA} | V |
| t_{START} | Comparator startup time | Fast mode | - | 15 | 20 | μs |
| | | Slow mode | - | 20 | 25 | |
| $t_{d\ slow}$ | Propagation delay ⁽²⁾ in slow mode | $1.65\text{ V} \leq V_{DDA} \leq 2.7\text{ V}$ | - | 1.8 | 3.5 | |
| | | $2.7\text{ V} \leq V_{DDA} \leq 3.6\text{ V}$ | - | 2.5 | 6 | |
| $t_{d\ fast}$ | Propagation delay ⁽²⁾ in fast mode | $1.65\text{ V} \leq V_{DDA} \leq 2.7\text{ V}$ | - | 0.8 | 2 | |
| | | $2.7\text{ V} \leq V_{DDA} \leq 3.6\text{ V}$ | - | 1.2 | 4 | |
| V_{offset} | Comparator offset error | | - | ± 4 | ± 20 | mV |
| $dThreshold/dt$ | Threshold voltage temperature coefficient | $V_{DDA} = 3.3\text{ V}$ $T_A = 0\text{ to }50\text{ }^\circ\text{C}$ $V^- = V_{REFINT}$ $3/4 V_{REFINT}$ $1/2 V_{REFINT}$ $1/4 V_{REFINT}$ | - | 15 | 30 | ppm/ $^\circ\text{C}$ |
| I_{COMP2} | Current consumption ⁽³⁾ | Fast mode | - | 3.5 | 5 | μA |
| | | Slow mode | - | 0.5 | 2 | |

1. Guaranteed by characterization results, not tested in production.
2. The delay is characterized for 100 mV input step with 10 mV overdrive on the inverting input, the non-inverting input set to the reference.
3. Comparator consumption only. Internal reference voltage (necessary for comparator operation) is not included.

6.3.18 Timer characteristics

TIM timer characteristics

The parameters given in the [Table 67](#) are guaranteed by design.

Refer to [Section 6.3.13: I/O port characteristics](#) for details on the input/output alternate function characteristics (output compare, input capture, external clock, PWM output).

Table 67. TIMx⁽¹⁾ characteristics

| Symbol | Parameter | Conditions | Min | Max | Unit |
|------------------|--|--------------------------------|--------|----------------------|---------------|
| $t_{res(TIM)}$ | Timer resolution time | | 1 | - | $t_{TIMxCLK}$ |
| | | $f_{TIMxCLK} = 32 \text{ MHz}$ | 31.25 | - | ns |
| f_{EXT} | Timer external clock frequency on CH1 to CH4 | | 0 | $f_{TIMxCLK}/2$ | MHz |
| | | $f_{TIMxCLK} = 32 \text{ MHz}$ | 0 | 16 | MHz |
| Res_{TIM} | Timer resolution | - | | 16 | bit |
| $t_{COUNTER}$ | 16-bit counter clock period when internal clock is selected (timer's prescaler disabled) | | 1 | 65536 | $t_{TIMxCLK}$ |
| | | $f_{TIMxCLK} = 32 \text{ MHz}$ | 0.0312 | 2048 | μs |
| t_{MAX_COUNT} | Maximum possible count | | - | 65536×65536 | $t_{TIMxCLK}$ |
| | | $f_{TIMxCLK} = 32 \text{ MHz}$ | - | 134.2 | s |

1. TIMx is used as a general term to refer to the TIM2, TIM6, TIM21, and TIM22 timers.

6.3.19 Communications interfaces

I²C interface characteristics

The I²C interface meets the timings requirements of the I²C-bus specification and user manual rev. 03 for:

- Standard-mode (Sm) : with a bit rate up to 100 kbit/s
- Fast-mode (Fm) : with a bit rate up to 400 kbit/s
- Fast-mode Plus (Fm+) : with a bit rate up to 1 Mbit/s.

The I²C timing requirements are guaranteed by design when the I²C peripheral is properly configured (refer to the reference manual for details). The SDA and SCL I/O requirements are met with the following restrictions: the SDA and SCL I/O pins are not "true" open-drain. When configured as open-drain, the PMOS connected between the I/O pin and VDDIOx is disabled, but is still present. Only FTf I/O pins support Fm+ low level output current maximum requirement (refer to [Section 6.3.13: I/O port characteristics](#) for the I2C I/Os characteristics).

All I²C SDA and SCL I/Os embed an analog filter (see [Table 68](#) for the analog filter characteristics).

Table 68. I2C analog filter characteristics⁽¹⁾

| Symbol | Parameter | Min | Max | Unit |
|-----------------|--|-------------------|--------------------|------|
| t _{AF} | Maximum pulse width of spikes that are suppressed by the analog filter | 50 ⁽²⁾ | 260 ⁽³⁾ | ns |

1. Guaranteed by design, not tested in production.
2. Spikes with widths below t_{AF(min)} are filtered.
3. Spikes with widths above t_{AF(max)} are not filtered

SPI characteristics

Unless otherwise specified, the parameters given in the following tables are derived from tests performed under ambient temperature, f_{PCLKx} frequency and V_{DD} supply voltage conditions summarized in [Table 23](#).

Refer to [Section 6.3.12: I/O current injection characteristics](#) for more details on the input/output alternate function characteristics (NSS, SCK, MOSI, MISO).

Table 69. SPI characteristics in voltage Range 1 ⁽¹⁾

| Symbol | Parameter | Conditions | Min | Typ | Max | Unit |
|--------------------------------|-----------------------------------|--|---------------|------------|-------------------|------|
| f_{SCK} 1/ $t_{c(SCK)}$ | SPI clock frequency | Master mode | - | - | 16 | MHz |
| | | Slave mode receiver | - | - | 16 | |
| | | Slave mode Transmitter 1.71< V_{DD} <3.6V | - | - | 12 ⁽²⁾ | |
| | | Slave mode Transmitter 2.7< V_{DD} <3.6V | - | - | 16 ⁽²⁾ | |
| Duty _(SCK) | Duty cycle of SPI clock frequency | Slave mode | 30 | 50 | 70 | % |
| $t_{su(NSS)}$ | NSS setup time | Slave mode, SPI presc = 2 | 4* T_{pclk} | - | - | ns |
| $t_{h(NSS)}$ | NSS hold time | Slave mode, SPI presc = 2 | 2* T_{pclk} | - | - | |
| $t_{w(SCKH)}$ $t_{w(SCKL)}$ | SCK high and low time | Master mode | $T_{pclk}-2$ | T_{pclk} | $T_{pclk}+2$ | |
| $t_{su(MI)}$ | Data input setup time | Master mode | 8.5 | - | - | |
| $t_{su(SI)}$ | | Slave mode | 8.5 | - | - | |
| $t_{h(MI)}$ | Data input hold time | Master mode | 6 | - | - | |
| $t_{h(SI)}$ | | Slave mode | 1 | - | - | |
| $t_{a(SO)}$ | Data output access time | Slave mode | 15 | - | 36 | |
| $t_{dis(SO)}$ | Data output disable time | Slave mode | 10 | - | 30 | |
| $t_{v(SO)}$ | Data output valid time | Slave mode 1.71< V_{DD} <3.6V | - | 29 | 41 | |
| | | Slave mode 2.7< V_{DD} <3.6V | - | 22 | 28 | |
| $t_{v(MO)}$ | | Master mode | - | 10 | 17 | |
| $t_{h(SO)}$ | Data output hold time | Slave mode | 9 | - | - | |
| $t_{h(MO)}$ | | Master mode | 3 | - | - | |

1. Guaranteed by characterization results, not tested in production.
2. The maximum SPI clock frequency in slave transmitter mode is determined by the sum of $t_{v(SO)}$ and $t_{su(MI)}$ which has to fit into SCK low or high phase preceding the SCK sampling edge. This value can be achieved when the SPI communicates with a master having $t_{su(MI)} = 0$ while Duty_(SCK) = 50%.

Table 70. SPI characteristics in voltage Range 2 ⁽¹⁾

| Symbol | Parameter | Conditions | Min | Typ | Max | Unit |
|--|-----------------------------------|--|---------|-------|------------------|------|
| f _{SCK} 1/t _{c(SCK)} | SPI clock frequency | Master mode | - | - | 8 | MHz |
| | | Slave mode Transmitter 1.65<V _{DD} <3.6V | | | 8 | |
| | | Slave mode Transmitter 2.7<V _{DD} <3.6V | | | 8 ⁽²⁾ | |
| Duty _(SCK) | Duty cycle of SPI clock frequency | Slave mode | 30 | 50 | 70 | % |
| t _{su(NSS)} | NSS setup time | Slave mode, SPI presc = 2 | 4*Tpclk | - | - | ns |
| t _{h(NSS)} | NSS hold time | Slave mode, SPI presc = 2 | 2*Tpclk | - | - | |
| t _{w(SCKH)} t _{w(SCKL)} | SCK high and low time | Master mode | Tpclk-2 | Tpclk | Tpclk+2 | |
| t _{su(MI)} | Data input setup time | Master mode | 12 | - | - | |
| t _{su(SI)} | | Slave mode | 11 | - | - | |
| t _{h(MI)} | Data input hold time | Master mode | 6.5 | - | - | |
| t _{h(SI)} | | Slave mode | 2 | - | - | |
| t _{a(SO)} | Data output access time | Slave mode | 18 | - | 52 | |
| t _{dis(SO)} | Data output disable time | Slave mode | 12 | - | 42 | |
| t _{v(SO)} | Data output valid time | Slave mode | - | 40 | 55 | |
| | | Master mode | - | 16 | 26 | |
| t _{v(MO)} | Data output hold time | Slave mode | 12 | - | - | |
| t _{h(SO)} | | Master mode | 4 | - | - | |

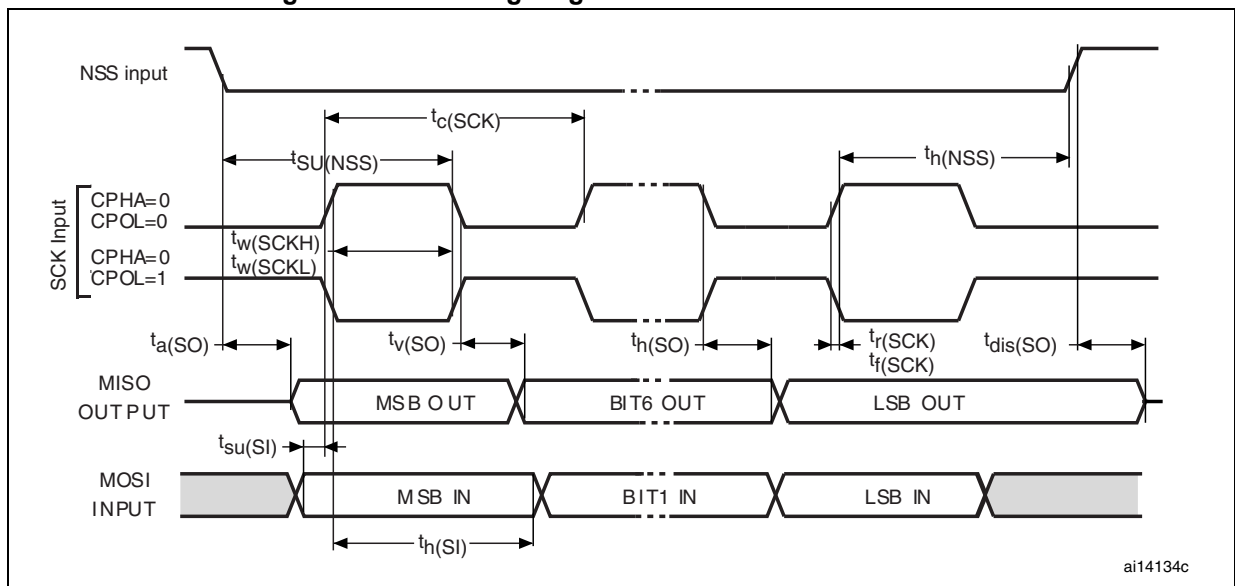
1. Guaranteed by characterization results, not tested in production.
2. The maximum SPI clock frequency in slave transmitter mode is determined by the sum of t_{v(SO)} and t_{su(MI)} which has to fit into SCK low or high phase preceding the SCK sampling edge. This value can be achieved when the SPI communicates with a master having t_{su(MI)} = 0 while Duty_(SCK) = 50%.

Table 71. SPI characteristics in voltage Range 3 ⁽¹⁾

| Symbol | Parameter | Conditions | Min | Typ | Max | Unit |
|----------------------------|-----------------------------------|---------------------------|-----------------|---------|-----------|------|
| f_{SCK} $1/t_c(SCK)$ | SPI clock frequency | Master mode | - | - | 2 | MHz |
| | | Slave mode | | | $2^{(2)}$ | |
| $Duty_{(SCK)}$ | Duty cycle of SPI clock frequency | Slave mode | 30 | 50 | 70 | % |
| $t_{su}(NSS)$ | NSS setup time | Slave mode, SPI presc = 2 | $4 \cdot Tpclk$ | - | - | ns |
| $t_h(NSS)$ | NSS hold time | Slave mode, SPI presc = 2 | $2 \cdot Tpclk$ | - | - | |
| $t_w(SCKH)$ $t_w(SCKL)$ | SCK high and low time | Master mode | $Tpclk-2$ | $Tpclk$ | $Tpclk+2$ | |
| $t_{su}(MI)$ | Data input setup time | Master mode | 28.5 | - | - | |
| $t_{su}(SI)$ | | Slave mode | 22 | - | - | |
| $t_h(MI)$ | Data input hold time | Master mode | 7 | - | - | |
| $t_h(SI)$ | | Slave mode | 5 | - | - | |
| $t_a(SO)$ | Data output access time | Slave mode | 30 | - | 70 | |
| $t_{dis}(SO)$ | Data output disable time | Slave mode | 40 | - | 80 | |
| $t_v(SO)$ | Data output valid time | Slave mode | - | 53 | 86 | |
| | | Master mode | - | 30 | 54 | |
| $t_v(MO)$ | Data output hold time | Slave mode | 18 | - | - | |
| $t_h(SO)$ | | Master mode | 8 | - | - | |

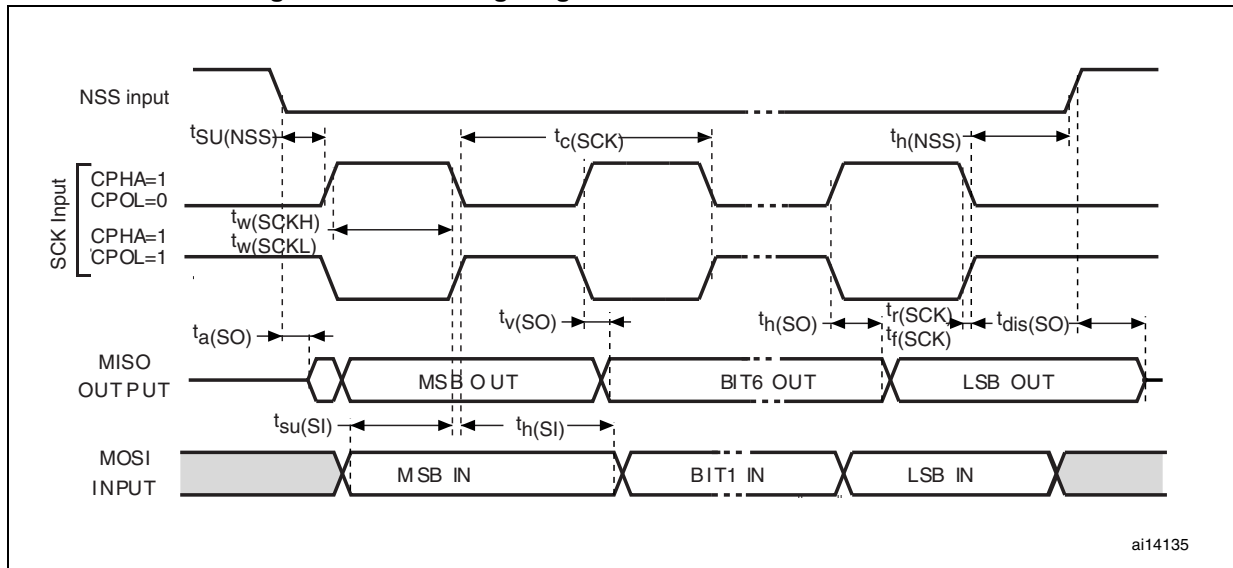
- Guaranteed by characterization results, not tested in production.
- The maximum SPI clock frequency in slave transmitter mode is determined by the sum of $t_v(SO)$ and $t_{su}(MI)$ which has to fit into SCK low or high phase preceding the SCK sampling edge. This value can be achieved when the SPI communicates with a master having $t_{su}(MI) = 0$ while $Duty_{(SCK)} = 50\%$.

Figure 32. SPI timing diagram - slave mode and CPHA = 0



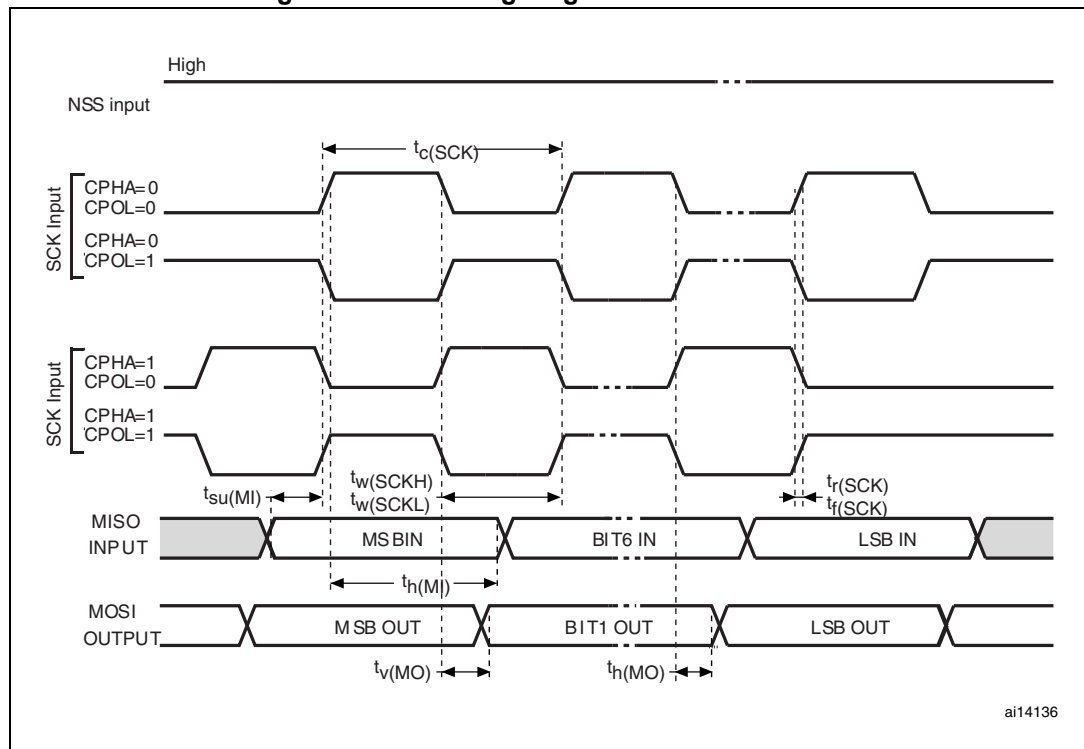
ai14134c

Figure 33. SPI timing diagram - slave mode and CPHA = 1⁽¹⁾



1. Measurement points are done at CMOS levels: 0.3V_{DD} and 0.7V_{DD}.

Figure 34. SPI timing diagram - master mode⁽¹⁾



1. Measurement points are done at CMOS levels: 0.3V_{DD} and 0.7V_{DD}.

I2S characteristics

Table 72. I2S characteristics⁽¹⁾

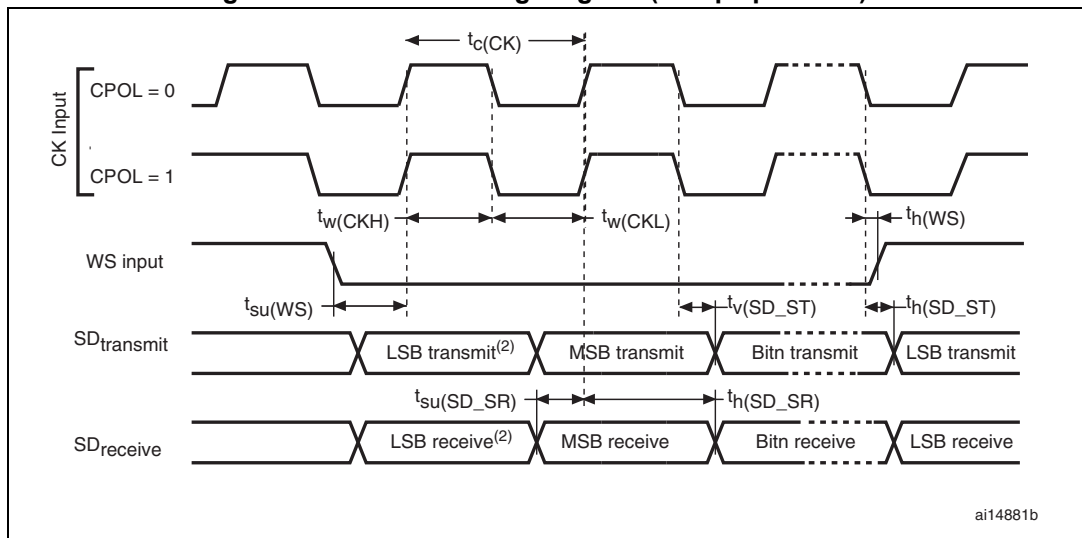
| Symbol | Parameter | Conditions | Min | Max | Unit |
|------------------------|--------------------------------|--|----------|-----------------------|------|
| f _{MCK} | I2S Main clock output | - | 256 x 8K | 256xFs ⁽²⁾ | MHz |
| f _{CK} | I2S clock frequency | Master data: 32 bits | - | 64xFs | MHz |
| | | Slave data: 32 bits | - | 64xFs | |
| D _{CK} | I2S clock frequency duty cycle | Slave receiver | 30 | 70 | % |
| t _{v(WS)} | WS valid time | Master mode | - | 15 | ns |
| t _{h(WS)} | WS hold time | Master mode | 11 | - | |
| t _{su(WS)} | WS setup time | Slave mode | 6 | - | |
| t _{h(WS)} | WS hold time | Slave mode | 2 | - | |
| t _{su(SD_MR)} | Data input setup time | Master receiver | 18 | - | |
| t _{su(SD_SR)} | | Slave receiver | 16 | - | |
| t _{h(SD_MR)} | Data input hold time | Master receiver | 11 | - | |
| t _{h(SD_SR)} | | Slave receiver | 0 | - | |
| t _{v(SD_ST)} | Data output valid time | Slave transmitter (after enable edge) | - | 77 | |
| t _{v(SD_MT)} | | Master transmitter (after enable edge) | - | 26 | |
| t _{h(SD_ST)} | Data output hold time | Slave transmitter (after enable edge) | 8 | - | |
| t _{h(SD_MT)} | | Master transmitter (after enable edge) | 3 | - | |

- 1. Guaranteed by characterization results, not tested in production.
- 2. 256xFs maximum value is equal to the maximum clock frequency.

Note: Refer to the I2S section of the product reference manual for more details about the sampling frequency (Fs), f_{MCK}, f_{CK} and D_{CK} values. These values reflect only the digital peripheral behavior, source clock precision might slightly change them. DCK depends mainly on the ODD bit value, digital contribution leads to a min of (I2SDIV/(2*I2SDIV+ODD)) and a max of (I2SDIV+ODD)/(2*I2SDIV+ODD). Fs max is supported for each mode/condition.

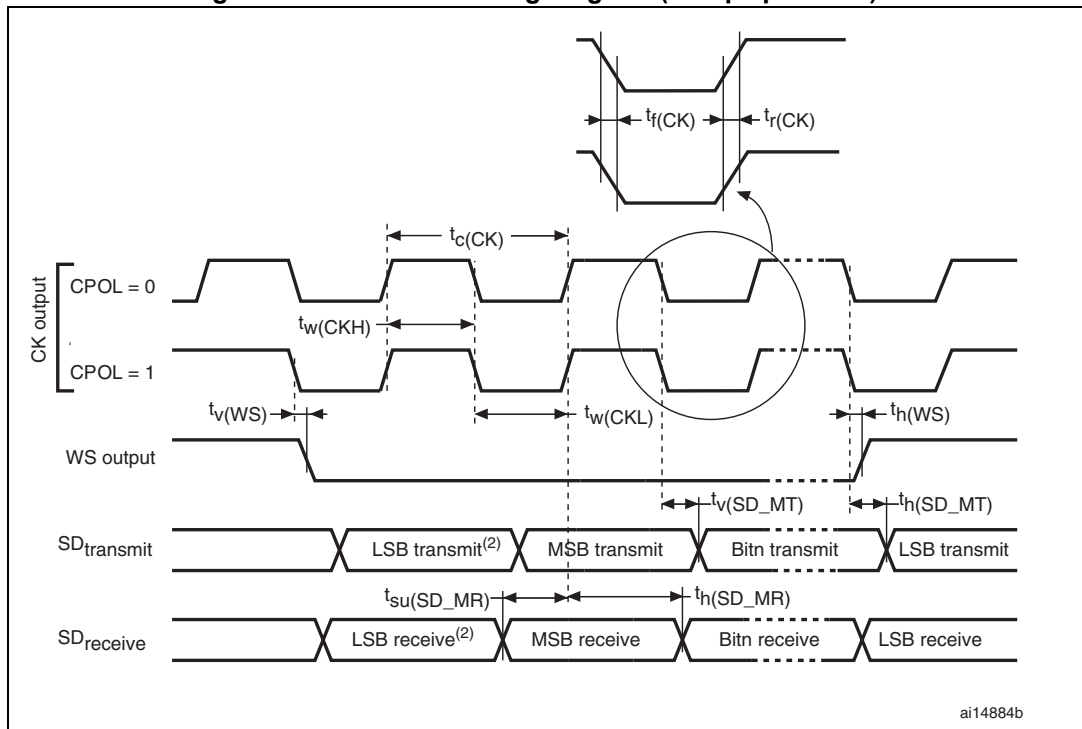


Figure 35. I²S slave timing diagram (Philips protocol)⁽¹⁾



1. Measurement points are done at CMOS levels: $0.3 \times V_{DD}$ and $0.7 \times V_{DD}$.
2. LSB transmit/receive of the previously transmitted byte. No LSB transmit/receive is sent before the first byte.

Figure 36. I²S master timing diagram (Philips protocol)⁽¹⁾



1. Guaranteed by characterization results, not tested in production.
2. LSB transmit/receive of the previously transmitted byte. No LSB transmit/receive is sent before the first byte.

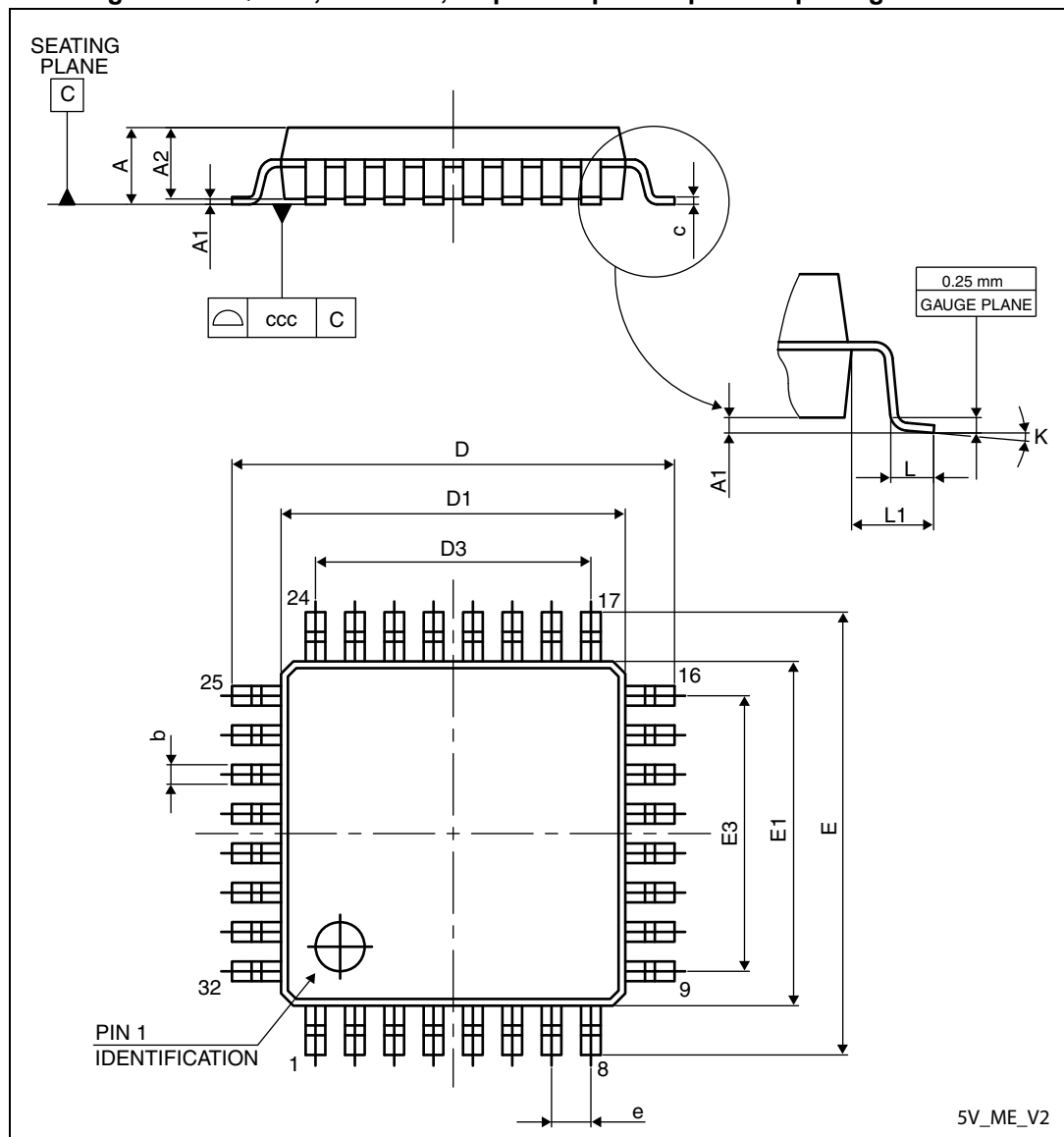
7 Package characteristics

7.1 Package mechanical data

In order to meet environmental requirements, ST offers these devices in different grades of ECOPACK® packages, depending on their level of environmental compliance. ECOPACK® specifications, grade definitions and product status are available at <http://www.st.com>. ECOPACK® is an ST trademark.

7.1.1 LQFP32 7 x 7 mm low profile quad flat package

Figure 37. LQFP32, 7 x 7 mm, 32-pin low-profile quad flat package outline



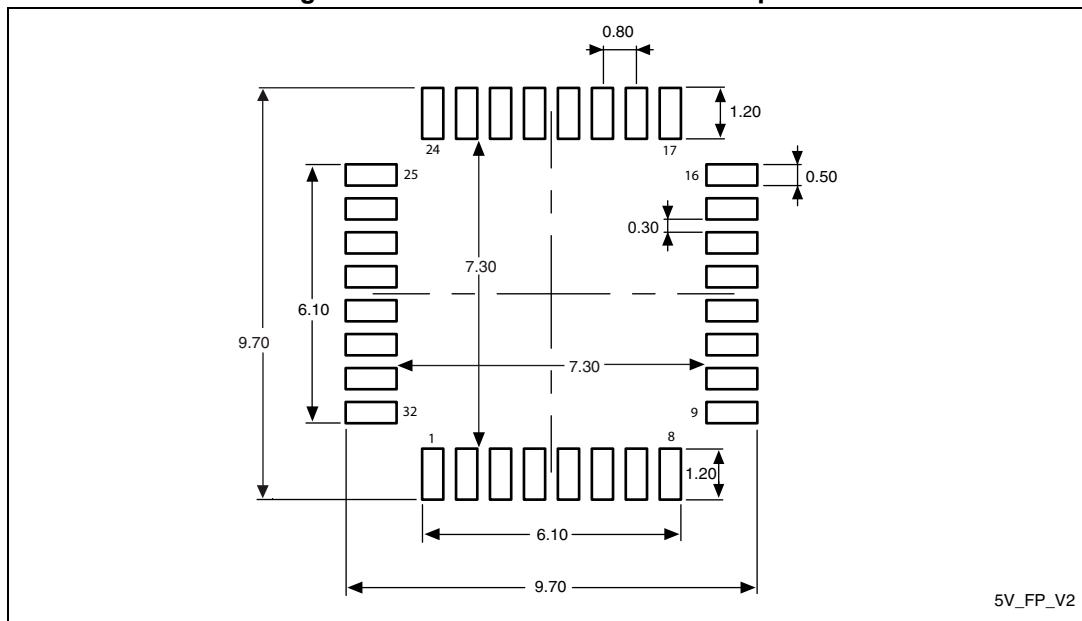
1. Drawing is not to scale.

Table 73. LQFP32, 7 x 7 mm, 32-pin low-profile quad flat package mechanical data

| Symbol | millimeters | | | inches ⁽¹⁾ | | |
|--------|-------------|-------|-------|-----------------------|--------|--------|
| | Min | Typ | Max | Min | Typ | Max |
| A | - | - | 1.600 | - | - | 0.0630 |
| A1 | 0.050 | - | 0.150 | 0.0020 | - | 0.0059 |
| A2 | 1.350 | 1.400 | 1.450 | 0.0531 | 0.0551 | 0.0571 |
| b | 0.300 | 0.370 | 0.450 | 0.0118 | 0.0146 | 0.0177 |
| c | 0.090 | - | 0.200 | 0.0035 | - | 0.0079 |
| D | 8.800 | 9.000 | 9.200 | 0.3465 | 0.3543 | 0.3622 |
| D1 | 6.800 | 7.000 | 7.200 | 0.2677 | 0.2756 | 0.2835 |
| D3 | - | 5.600 | - | - | 0.2205 | - |
| E | 8.800 | 9.000 | 9.200 | 0.3465 | 0.3543 | 0.3622 |
| E1 | 6.800 | 7.000 | 7.200 | 0.2677 | 0.2756 | 0.2835 |
| E3 | - | 5.600 | - | - | 0.2205 | - |
| e | - | 0.800 | - | - | 0.0315 | - |
| L | 0.450 | 0.600 | 0.750 | 0.0177 | 0.0236 | 0.0295 |
| L1 | - | 1.000 | - | - | 0.0394 | - |
| ccc | - | - | 0.100 | - | - | 0.0039 |
| A | - | - | 1.600 | - | - | 0.0630 |

1. Values in inches are converted from mm and rounded to 4 decimal digits.

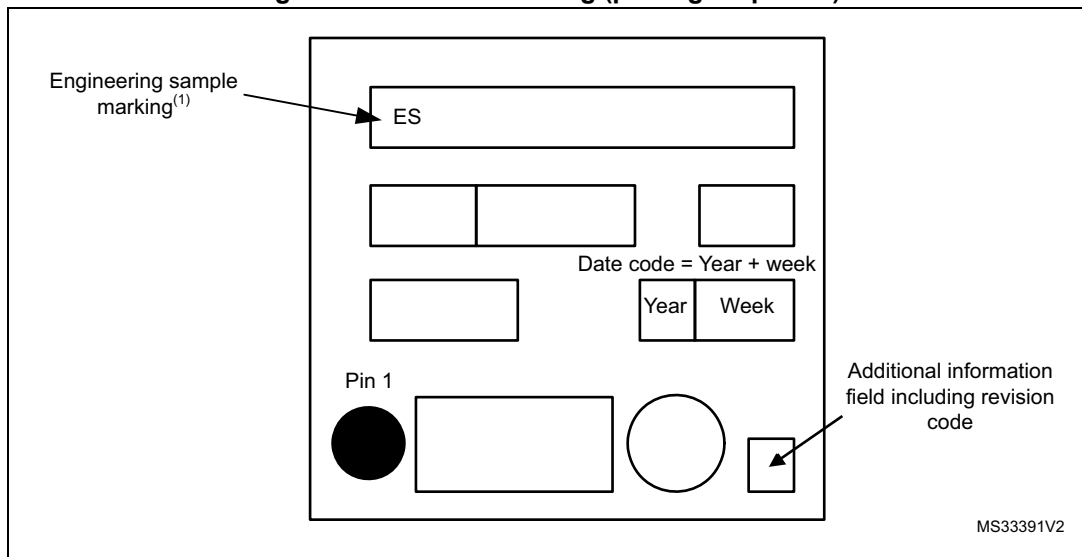
Figure 38. LQFP32 recommended footprint



1. Dimensions are expressed in millimeters.

Device marking

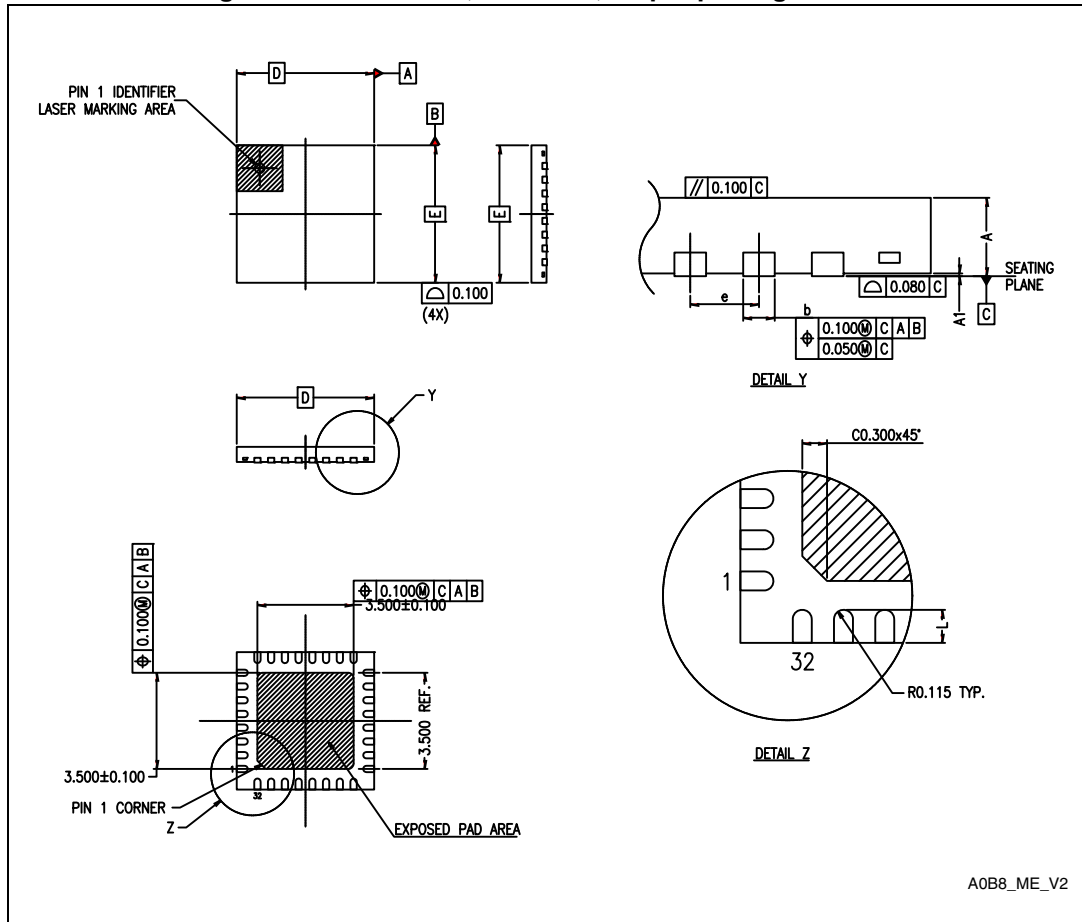
Figure 39. LQFP32 marking (package top view)



1. Samples marked "ES" are to be considered as "Engineering Samples": i.e. they are intended to be sent to customer for electrical compatibility evaluation and may be used to start customer qualification where specifically authorized by ST in writing. In no event ST will be liable for any customer usage in production. Only if ST has authorized in writing the customer qualification Engineering Samples can be used for reliability qualification trials.

7.1.2 UFQFPN32 5 x 5 mm package

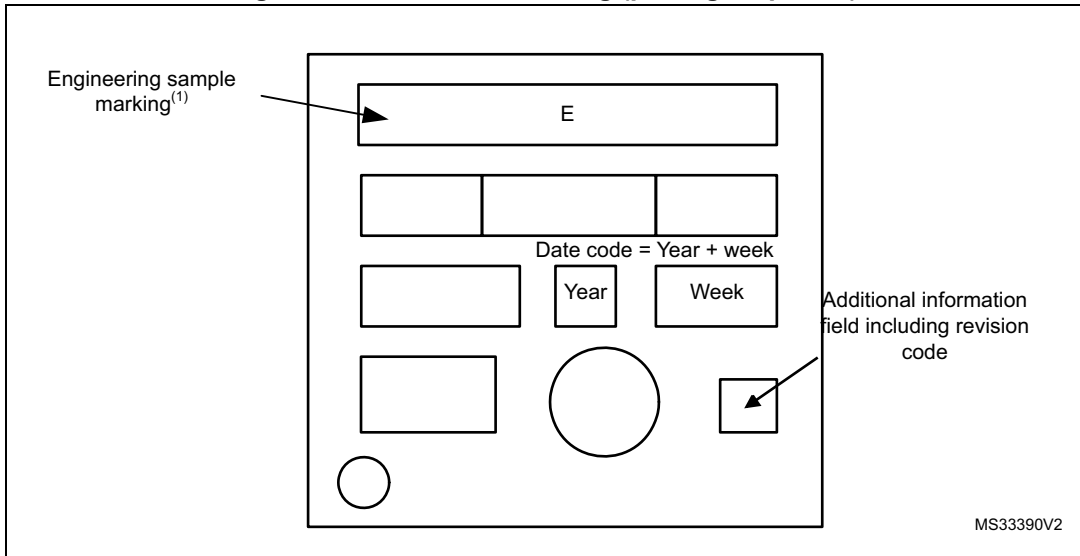
Figure 40. UFQFPN32, 5 x 5 mm, 32-pin package outline



1. Drawing is not to scale.

Device marking

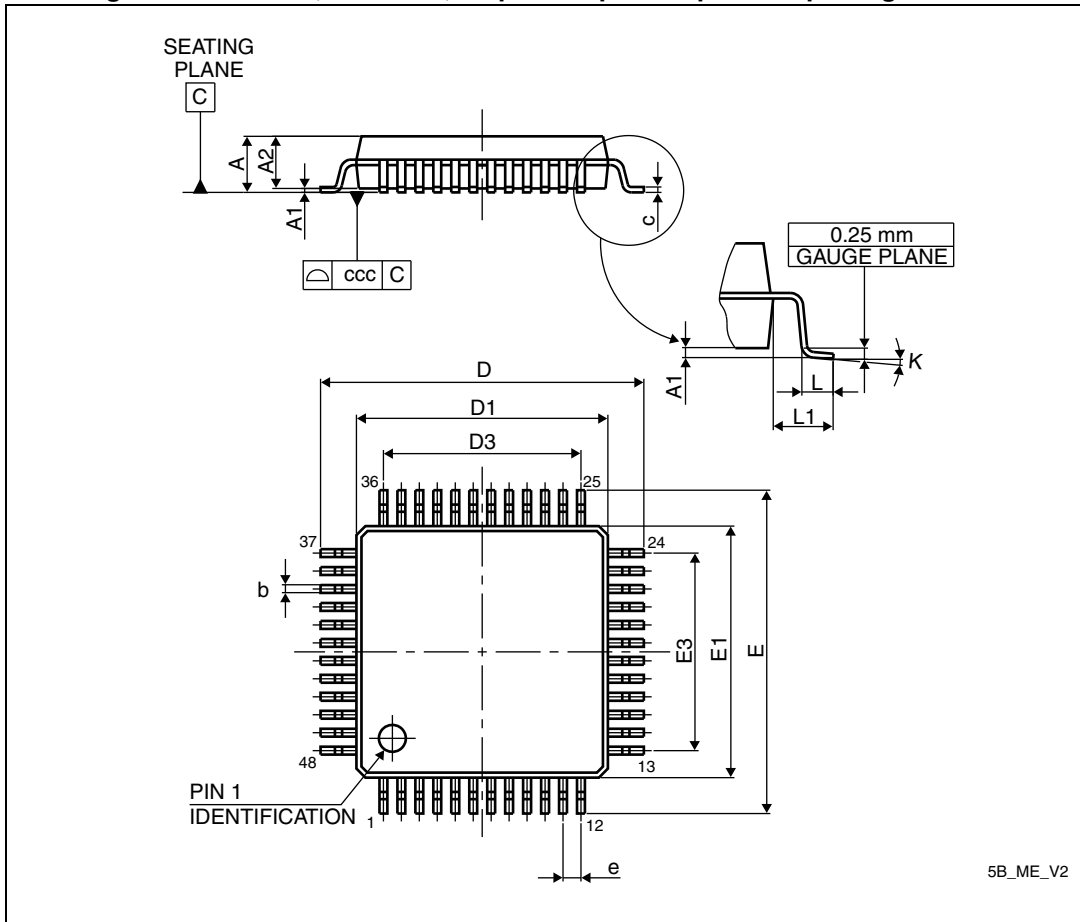
Figure 42. UFQFPN32 marking (package top view)



1. Samples marked "E" are to be considered as "Engineering Samples": i.e. they are intended to be sent to customer for electrical compatibility evaluation and may be used to start customer qualification where specifically authorized by ST in writing. In no event ST will be liable for any customer usage in production. Only if ST has authorized in writing the customer qualification Engineering Samples can be used for reliability qualification trials.

7.1.3 LQFP48 7 x 7 mm low profile quad flat package

Figure 43. LQFP48, 7 x 7 mm, 48-pin low-profile quad flat package outline



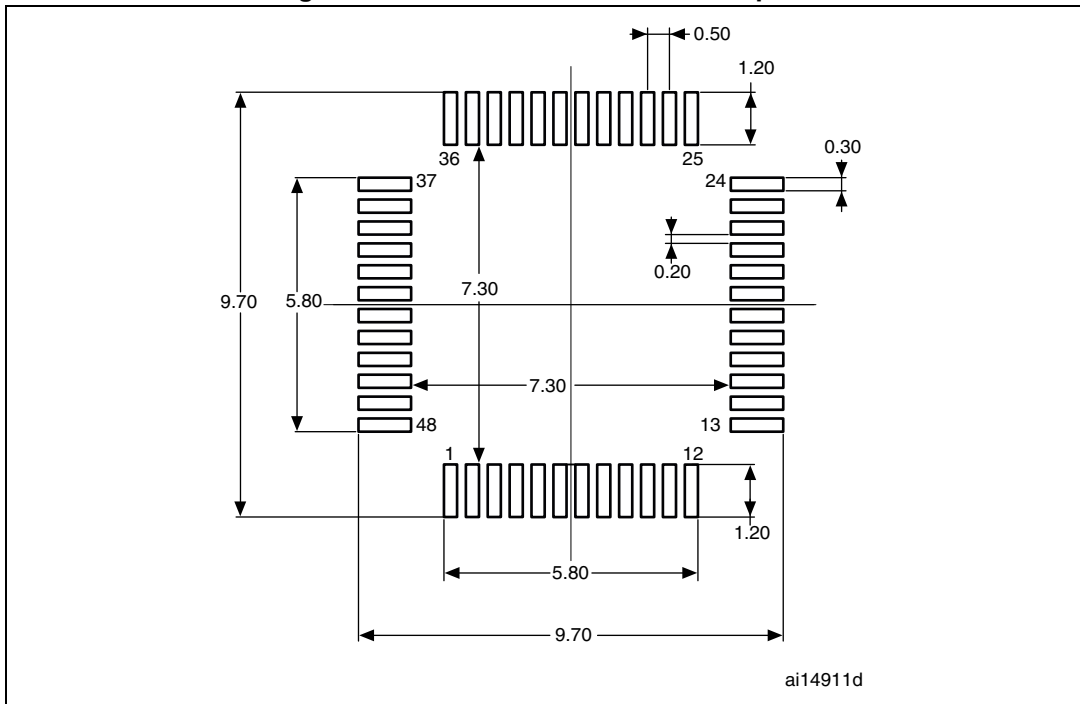
1. Drawing is not to scale.

Table 75. LQFP48, 7 x 7 mm, 48-pin low-profile quad flat package mechanical data

| Symbol | millimeters | | | inches ⁽¹⁾ | | |
|--------|-------------|-------|-------|-----------------------|--------|--------|
| | Min | Typ | Max | Min | Typ | Max |
| A | - | - | 1.600 | - | - | 0.0630 |
| A1 | 0.050 | - | 0.150 | 0.0020 | - | 0.0059 |
| A2 | 1.350 | 1.400 | 1.450 | 0.0531 | 0.0551 | 0.0571 |
| b | 0.170 | 0.220 | 0.270 | 0.0067 | 0.0087 | 0.0106 |
| c | 0.090 | - | 0.200 | 0.0035 | - | 0.0079 |
| D | 8.800 | 9.000 | 9.200 | 0.3465 | 0.3543 | 0.3622 |
| D1 | 6.800 | 7.000 | 7.200 | 0.2677 | 0.2756 | 0.2835 |
| D3 | - | 5.500 | - | - | 0.2165 | - |
| E | 8.800 | 9.000 | 9.200 | 0.3465 | 0.3543 | 0.3622 |
| E1 | 6.800 | 7.000 | 7.200 | 0.2677 | 0.2756 | 0.2835 |
| E3 | - | 5.500 | - | - | 0.2165 | - |
| e | - | 0.500 | - | - | 0.0197 | - |
| L | 0.450 | 0.600 | 0.750 | 0.0177 | 0.0236 | 0.0295 |
| L1 | - | 1.000 | - | - | 0.0394 | - |
| k | 0° | 3.5° | 7° | 0° | 3.5° | 7° |
| ccc | - | - | 0.080 | - | - | 0.0031 |

1. Values in inches are converted from mm and rounded to 4 decimal digits.

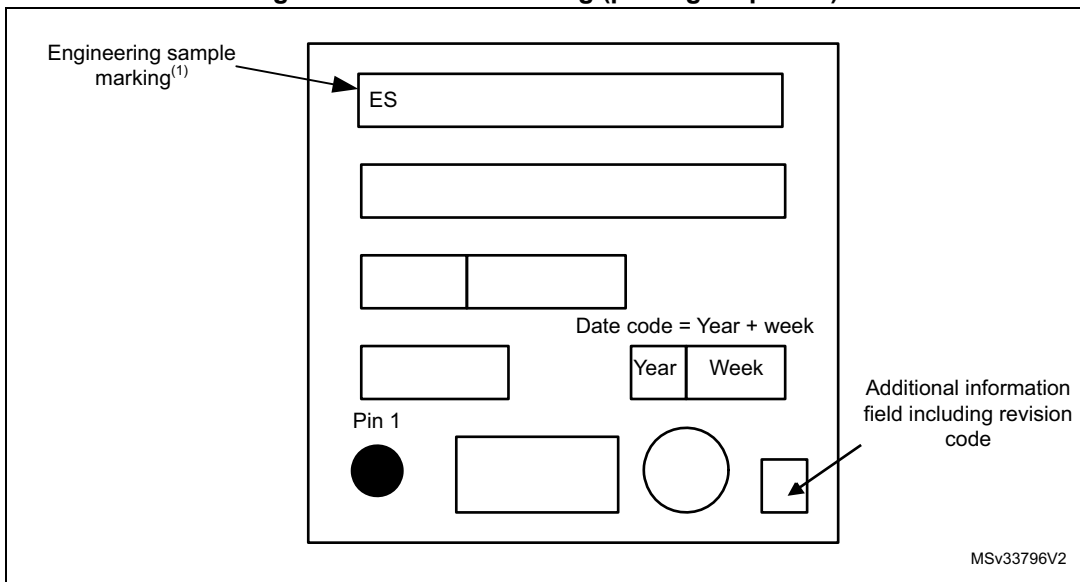
Figure 44. LQFP48 recommended footprint



1. Dimensions are expressed in millimeters.

Device marking

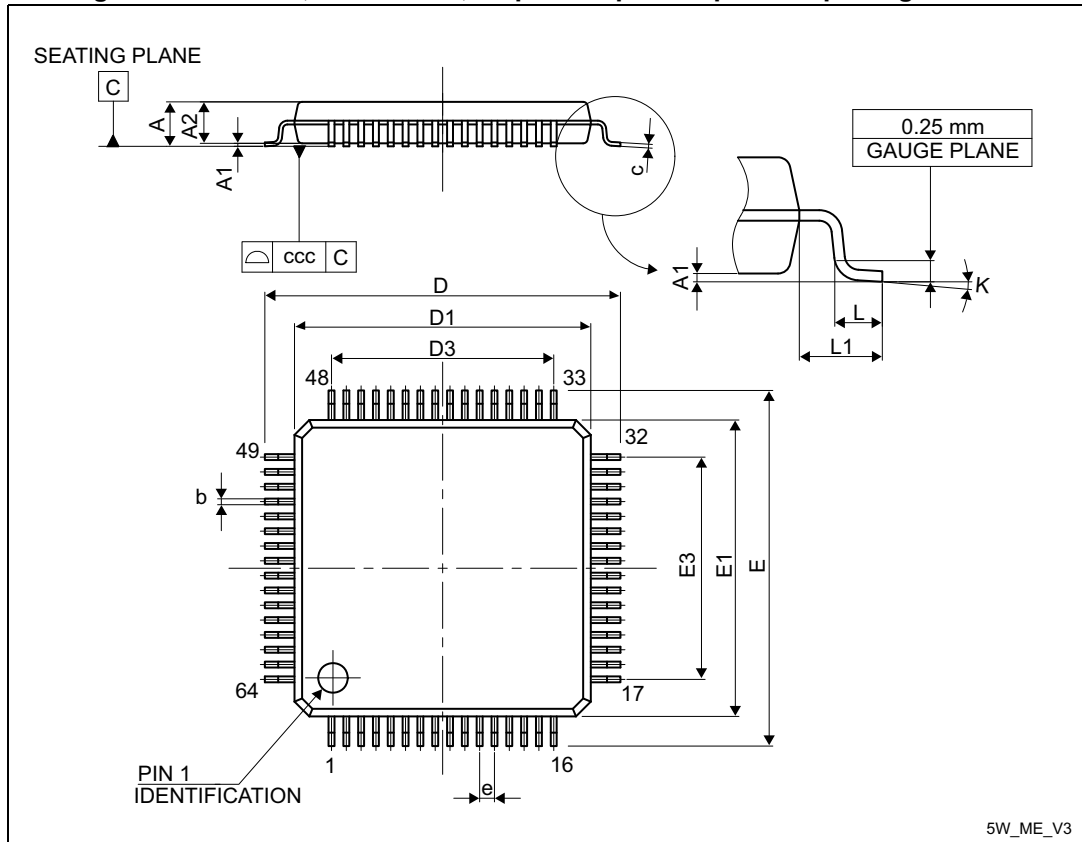
Figure 45. LQFP48 marking (package top view)



1. Samples marked "ES" are to be considered as "Engineering Samples": i.e. they are intended to be sent to customer for electrical compatibility evaluation and may be used to start customer qualification where specifically authorized by ST in writing. In no event ST will be liable for any customer usage in production. Only if ST has authorized in writing the customer qualification Engineering Samples can be used for reliability qualification trials.

7.1.4 LQFP64 10 x 10 mm low profile quad flat package

Figure 46. LQFP64, 10 x 10 mm, 64-pin low-profile quad flat package outline



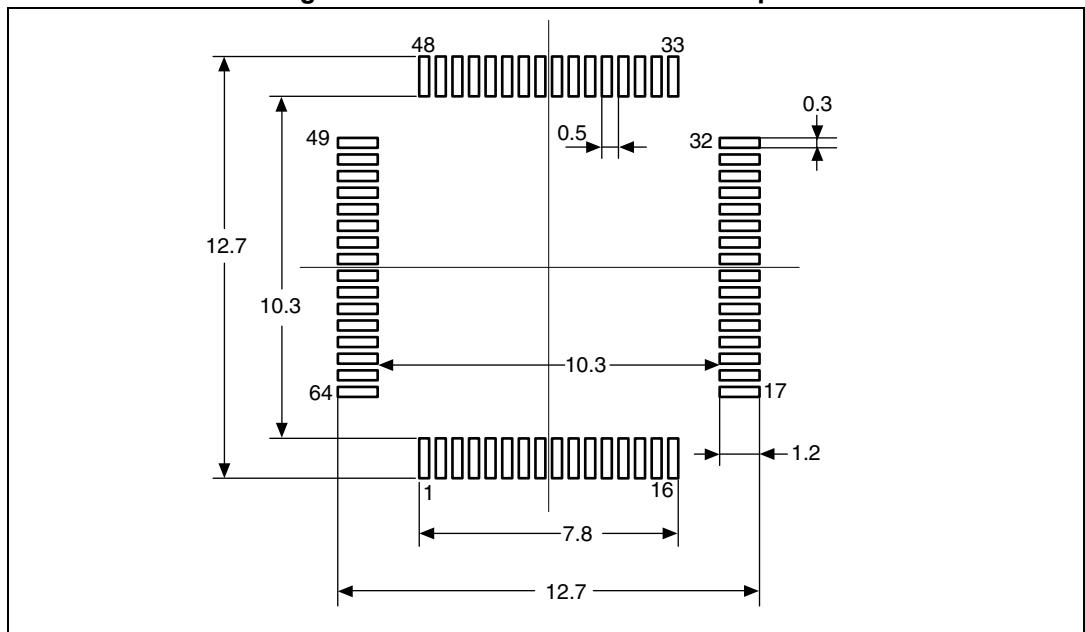
1. Drawing is not to scale.

Table 76. LQFP64, 10 x 10 mm 64-pin low-profile quad flat package mechanical data

| Symbol | millimeters | | | inches ⁽¹⁾ | | |
|--------|-------------|--------|--------|-----------------------|--------|--------|
| | Min | Typ | Max | Min | Typ | Max |
| A | - | - | 1.600 | - | - | 0.0630 |
| A1 | 0.050 | - | 0.150 | 0.0020 | - | 0.0059 |
| A2 | 1.350 | 1.400 | 1.450 | 0.0531 | 0.0551 | 0.0571 |
| b | 0.170 | 0.220 | 0.270 | 0.0067 | 0.0087 | 0.0106 |
| c | 0.090 | - | 0.200 | 0.0035 | - | 0.0079 |
| D | 11.800 | 12.000 | 12.200 | 0.4646 | 0.4724 | 0.4803 |
| D1 | 9.800 | 10.000 | 10.200 | 0.3858 | 0.3937 | 0.4016 |
| D3 | - | 7.500 | - | - | 0.2953 | - |
| E | 11.800 | 12.000 | 12.200 | 0.4646 | 0.4724 | 0.4803 |
| E1 | 9.800 | 10.000 | 10.200 | 0.3858 | 0.3937 | 0.4016 |
| E3 | - | 7.500 | - | - | 0.2953 | - |
| e | - | 0.500 | - | - | 0.0197 | - |
| L | 0.450 | 0.600 | 0.750 | 0.0177 | 0.0236 | 0.0295 |
| L1 | - | 1.000 | - | - | 0.0394 | - |
| ccc | - | - | 0.080 | - | - | 0.0031 |
| K | 0.0 | 3.5 | 7.0 | 0.0 | 3.5 | 7.0 |

1. Values in inches are converted from mm and rounded to 4 decimal digits.

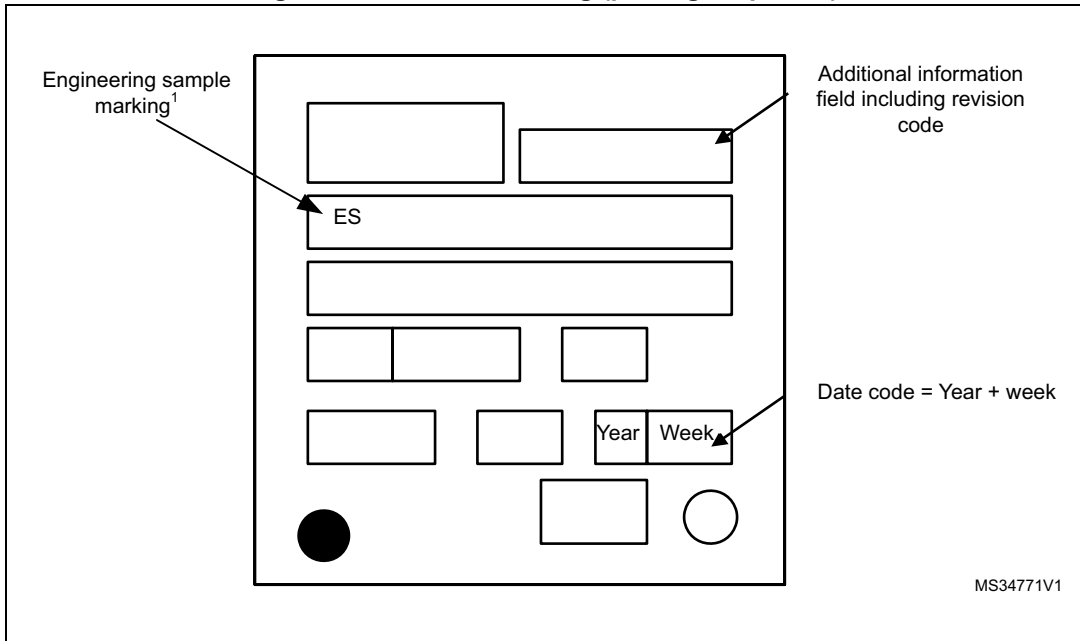
Figure 47. LQFP64 recommended footprint



1. Dimensions are expressed in millimeters

Device marking

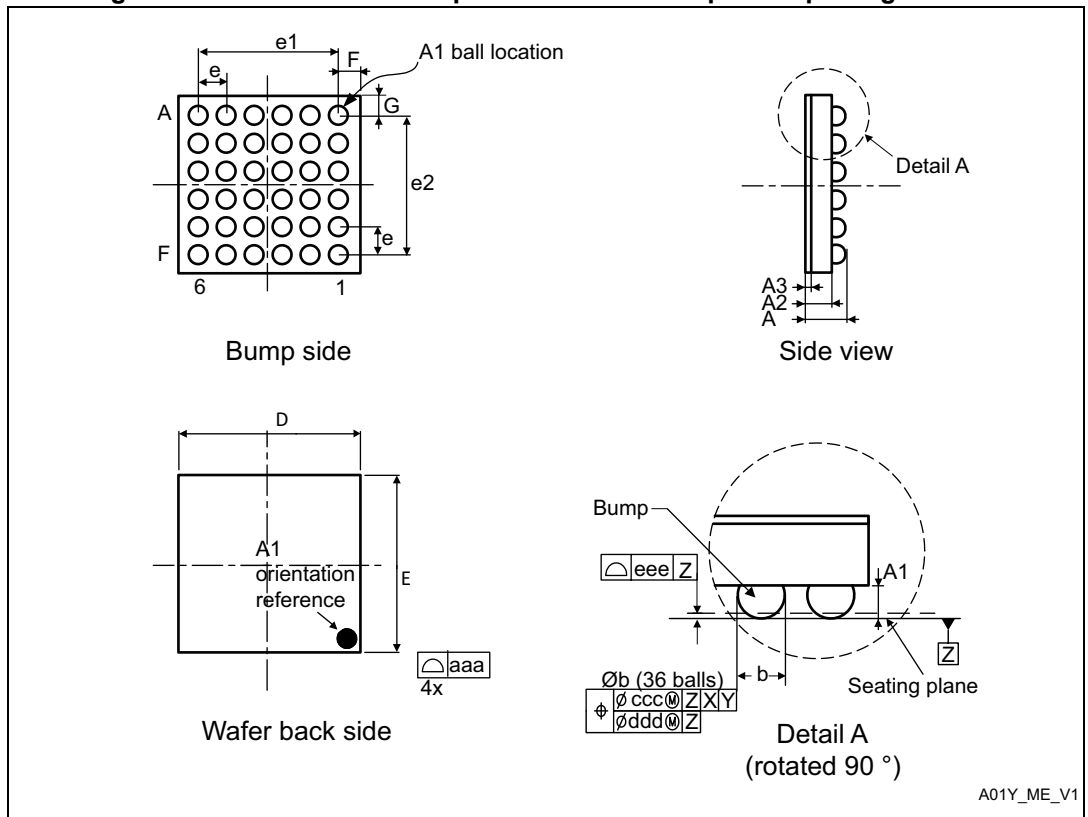
Figure 48. LQFP64 marking (package top view)



1. Samples marked "ES" are to be considered as "Engineering Samples": i.e. they are intended to be sent to customer for electrical compatibility evaluation and may be used to start customer qualification where specifically authorized by ST in writing. In no event ST will be liable for any customer usage in production. Only if ST has authorized in writing the customer qualification Engineering Samples can be used for reliability qualification trials.

7.1.5 WLCSP36 0.4 mm pitch wafer-level chip scale package

Figure 49. WLCSP36 0.4 mm pitch wafer-level chip scale package outline



1. Drawing is not to scale.

Table 77. WLCSP36 0.4 mm pitch wafer-level chip scale package mechanical data

| Symbol | millimeters | | | inches ⁽¹⁾ | | |
|-------------------|-------------|-------|-------|-----------------------|--------|--------|
| | Min | Typ | Max | Min | Typ | Max |
| A | 0.525 | 0.555 | 0.585 | 0.0207 | 0.0219 | 0.0230 |
| A1 | - | 0.175 | - | - | 0.0069 | - |
| A2 | - | 0.380 | - | - | 0.0150 | - |
| A3 ⁽²⁾ | - | 0.025 | - | - | 0.0010 | - |
| b | 0.220 | 0.250 | 0.280 | 0.0087 | 0.0098 | 0.0110 |
| D | 2.561 | 2.596 | 2.631 | 0.1008 | 0.1022 | 0.1036 |
| E | 2.833 | 2.868 | 2.903 | 0.1115 | 0.1129 | 0.1143 |
| e | - | 0.400 | - | - | 0.0157 | - |
| e1 | - | 2.000 | - | - | 0.0787 | - |
| e2 | - | 2.000 | - | - | 0.0787 | - |
| F | - | 0.298 | - | - | 0.0117 | - |

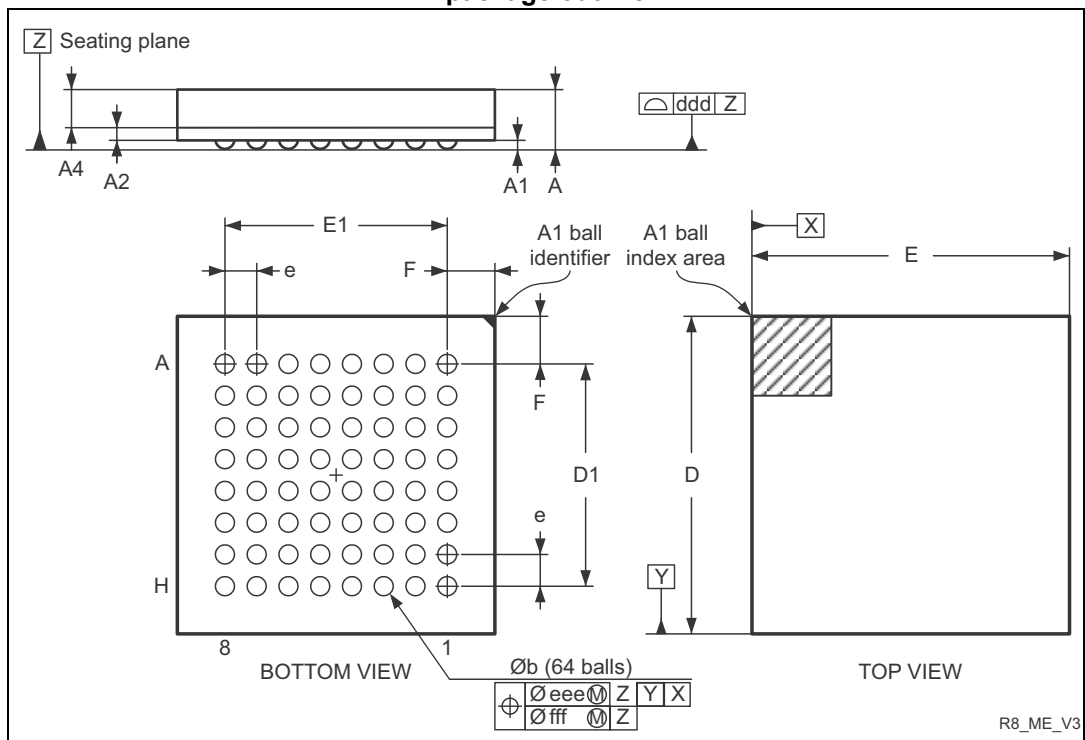
Table 77. WLCSP36 0.4 mm pitch wafer-level chip scale package mechanical data (continued)

| Symbol | millimeters | | | inches ⁽¹⁾ | | |
|--------|-------------|-------|-----|-----------------------|--------|-----|
| | Min | Typ | Max | Min | Typ | Max |
| G | - | 0.434 | - | - | 0.0171 | - |
| aaa | - | 0.100 | - | - | 0.0039 | - |
| bbb | - | 0.100 | - | - | 0.0039 | - |
| ccc | - | 0.100 | - | - | 0.0039 | - |
| ddd | - | 0.050 | - | - | 0.0020 | - |
| eee | - | 0.050 | - | - | 0.0020 | - |

1. Values in inches are converted from mm and rounded to 4 decimal digits.
2. Back side coating

7.1.6 TFBGA64 5 x 5 mm thin profile fine pitch ball grid array package

Figure 50. TFBGA64, 5 x 5 mm, 64-bump thin profile fine pitch ball grid array package outline



1. Drawing is not to scale.

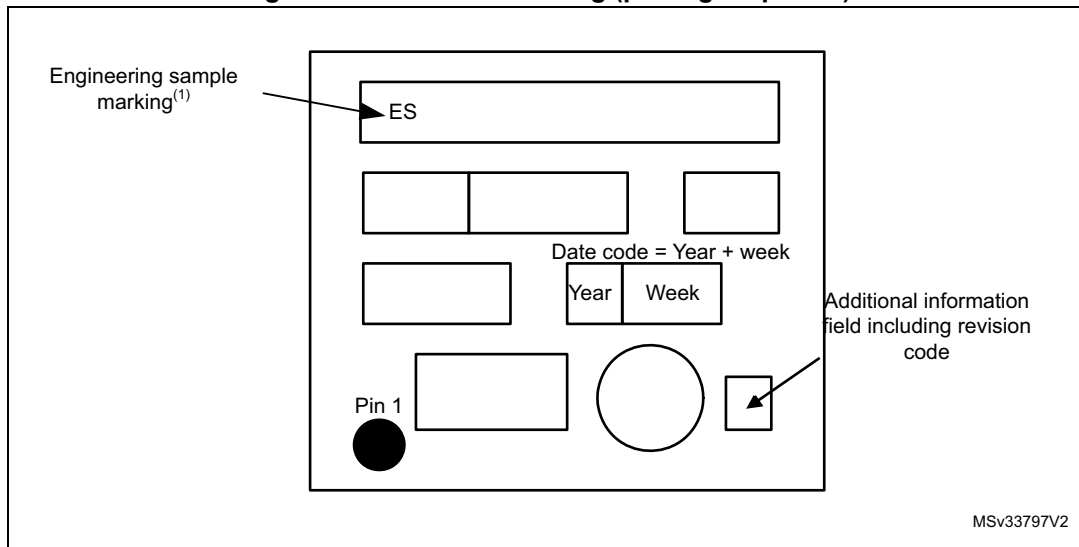
Table 78. TFBGA64, 5 x 5 mm, 64-bump thin profile fine pitch ball grid array package mechanical data

| Symbol | millimeters | | | inches ⁽¹⁾ | | |
|--------|-------------|-------|-------|-----------------------|--------|--------|
| | Min | Typ | Max | Min | Typ | Max |
| A | - | - | 1.200 | - | - | 0.0472 |
| A1 | 0.150 | - | - | 0.0059 | - | - |
| A2 | - | 0.200 | - | - | 0.0079 | - |
| A4 | - | - | 0.600 | - | - | 0.0236 |
| b | 0.250 | 0.300 | 0.350 | 0.0098 | 0.0118 | 0.0138 |
| D | 4.850 | 5.000 | 5.150 | 0.1909 | 0.1969 | 0.2028 |
| D1 | - | 3.500 | - | - | 0.1378 | - |
| E | 4.850 | 5.000 | 5.150 | 0.1909 | 0.1969 | 0.2028 |
| E1 | - | 3.500 | - | - | 0.1378 | - |
| e | - | 0.500 | - | - | 0.0197 | - |
| F | - | 0.750 | - | - | 0.0295 | - |
| ddd | - | - | 0.080 | - | - | 0.0031 |
| eee | - | - | 0.150 | - | - | 0.0059 |
| fff | - | - | 0.050 | - | - | 0.0020 |

1. Values in inches are converted from mm and rounded to 4 decimal digits.

Device marking

Figure 51. TFBGA64 marking (package top view)



1. Samples marked "ES" are to be considered as "Engineering Samples": i.e. they are intended to be sent to customer for electrical compatibility evaluation and may be used to start customer qualification where specifically authorized by ST in writing. In no event ST will be liable for any customer usage in production. Only if ST has authorized in writing the customer qualification Engineering Samples can be used for reliability qualification trials.

7.2 Thermal characteristics

The maximum chip-junction temperature, $T_J \text{ max}$, in degrees Celsius, may be calculated using the following equation:

$$T_J \text{ max} = T_A \text{ max} + (P_D \text{ max} \times \Theta_{JA})$$

Where:

- $T_A \text{ max}$ is the maximum ambient temperature in °C,
- Θ_{JA} is the package junction-to-ambient thermal resistance, in °C/W,
- $P_D \text{ max}$ is the sum of $P_{INT} \text{ max}$ and $P_{I/O} \text{ max}$ ($P_D \text{ max} = P_{INT} \text{ max} + P_{I/O} \text{ max}$),
- $P_{INT} \text{ max}$ is the product of I_{DD} and V_{DD} , expressed in Watts. This is the maximum chip internal power.

$P_{I/O} \text{ max}$ represents the maximum power dissipation on output pins where:

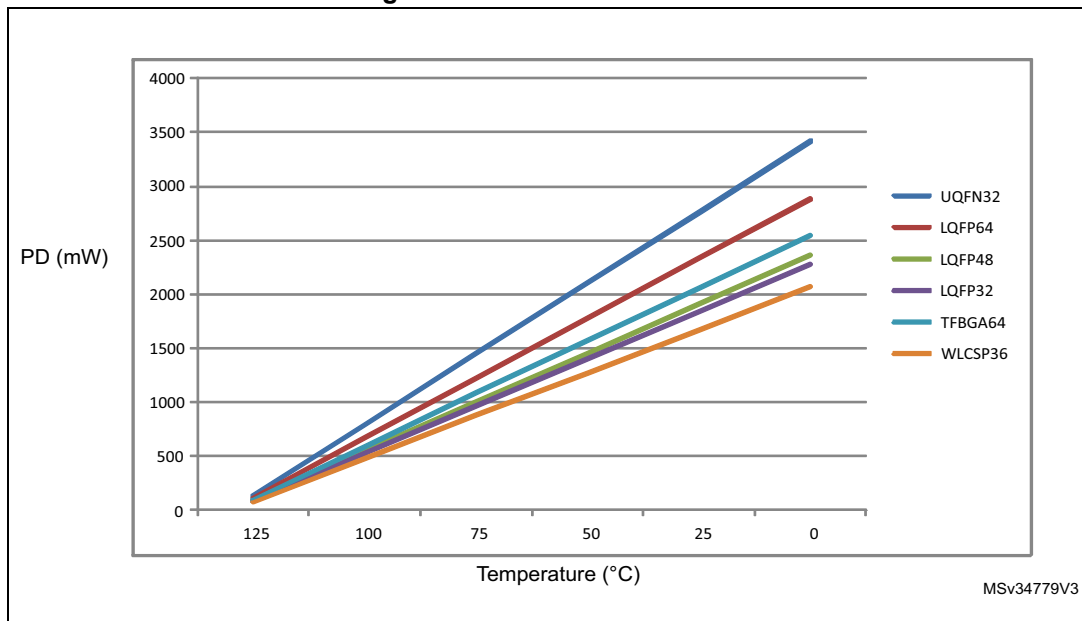
$$P_{I/O} \text{ max} = \Sigma (V_{OL} \times I_{OL}) + \Sigma (V_{DD} - V_{OH}) \times I_{OH},$$

taking into account the actual V_{OL} / I_{OL} and V_{OH} / I_{OH} of the I/Os at low and high level in the application.

Table 79. Thermal characteristics

| Symbol | Parameter | Value | Unit |
|---------------|---|-------|------|
| Θ_{JA} | Thermal resistance junction-ambient TFBGA64 - 5 x 5 mm / 0.5 mm pitch | 61 | °C/W |
| | Thermal resistance junction-ambient LQFP64 - 10 x 10 mm / 0.5 mm pitch | 45 | |
| | Thermal resistance junction-ambient WLCSP36 - 0.4 mm pitch | 63 | |
| | Thermal resistance junction-ambient LQFP48 - 7 x 7 mm / 0.5 mm pitch | 55 | |
| | Thermal resistance junction-ambient LQFP32 - 7 x 7 mm / 0.8 mm pitch | 57 | |
| | Thermal resistance junction-ambient UFQFPN32 - 5 x 5 mm / 0.5 mm pitch | 38 | |

Figure 52. Thermal resistance



7.2.1 Reference document

JESD51-2 Integrated Circuits Thermal Test Method Environment Conditions - Natural Convection (Still Air). Available from www.jedec.org.

8 Ordering information

Table 80. STM32L051x6/8 ordering information scheme

| Example: | STM32 | L | 051 | R | 8 | T | 6 | D | xxx |
|--|---|---|-----|---|---|---|---|---|-----|
| Device family | <div style="border-left: 1px solid black; border-right: 1px solid black; border-bottom: 1px solid black; height: 100%; position: relative;"> <div style="position: absolute; top: 0; left: 0; right: 0; border-bottom: 1px solid black;"></div> <div style="position: absolute; top: 0; left: 0; right: 0; border-bottom: 1px solid black;"></div> <div style="position: absolute; top: 0; left: 0; right: 0; border-bottom: 1px solid black;"></div> <div style="position: absolute; top: 0; left: 0; right: 0; border-bottom: 1px solid black;"></div> <div style="position: absolute; top: 0; left: 0; right: 0; border-bottom: 1px solid black;"></div> <div style="position: absolute; top: 0; left: 0; right: 0; border-bottom: 1px solid black;"></div> <div style="position: absolute; top: 0; left: 0; right: 0; border-bottom: 1px solid black;"></div> <div style="position: absolute; top: 0; left: 0; right: 0; border-bottom: 1px solid black;"></div> <div style="position: absolute; top: 0; left: 0; right: 0; border-bottom: 1px solid black;"></div> <div style="position: absolute; top: 0; left: 0; right: 0; border-bottom: 1px solid black;"></div> </div> | | | | | | | | |
| STM32 = ARM-based 32-bit microcontroller | | | | | | | | | |
| Product type | | | | | | | | | |
| L = Low power | | | | | | | | | |
| Device subfamily | | | | | | | | | |
| 051 = Access line | | | | | | | | | |
| Pin count | | | | | | | | | |
| K = 32 pins | | | | | | | | | |
| T = 36 pins | | | | | | | | | |
| C = 48/49 pins | | | | | | | | | |
| R = 64 pins | | | | | | | | | |
| Flash memory size | | | | | | | | | |
| 6 = 32 Kbytes | | | | | | | | | |
| 8 = 64 Kbytes | | | | | | | | | |
| Package | | | | | | | | | |
| T = LQFP | | | | | | | | | |
| H = TFBGA | | | | | | | | | |
| U = UFQFPN | | | | | | | | | |
| Y = WLCSP pins | | | | | | | | | |
| Temperature range | | | | | | | | | |
| 6 = Industrial temperature range, -40 to 85 °C | | | | | | | | | |
| 7 = Industrial temperature range, -40 to 105 °C | | | | | | | | | |
| 3 = Industrial temperature range, -40 to 125 °C | | | | | | | | | |
| Options | | | | | | | | | |
| No character = V _{DD} range: 1.8 to 3.6 V and BOR enabled | | | | | | | | | |
| D = V _{DD} range: 1.65 to 3.6 V and BOR disabled | | | | | | | | | |
| Packing | | | | | | | | | |
| TR = tape and reel | | | | | | | | | |
| No character = tray or tube | | | | | | | | | |

For a list of available options (speed, package, etc.) or for further information on any aspect of this device, please contact your nearest ST sales office.



9 Revision history

Table 81. Document revision history

| Date | Revision | Changes |
|-------------|----------|--|
| 13-Feb-2014 | 1 | Initial release. |
| 29-Apr-2014 | 2 | <p>Added WLCSP36 package. Updated Table 2: Ultra-low-power STM32L051x6/x8 device features and peripheral counts</p> <p>Updated Table 5: Functionalities depending on the working mode (from Run/active down to standby). Added Section 3.2: Interconnect matrix.</p> <p>Updated Figure 8: STM32L051x6/8 TFBGA64 ballout - 5x 5 mm</p> <p>Replaced Tta I/O structure by TC, updated PA0/4/5, PC5/14, BOOT0 and NRST I/O structure in Table 15: STM32L051x6/8 pin definitions.</p> <p>Updated Table 23: General operating conditions, Table 20: Voltage characteristics and Table 21: Current characteristics.</p> <p>Modified conditions in Table 26: Embedded internal reference voltage.</p> <p>Updated Table 27: Current consumption in Run mode, code with data processing running from Flash, Table 29: Current consumption in Run mode, code with data processing running from RAM, Table 31: Current consumption in Sleep mode, Table 32: Current consumption in Low-power Run mode, Table 33: Current consumption in Low-power Sleep mode, Table 34: Typical and maximum current consumptions in Stop mode and Table 35: Typical and maximum current consumptions in Standby mode. Added Figure 14: IDD vs VDD, at TA= 25/55/85/105 °C, Run mode, code running from Flash memory, Range 2, HSE, 1WS, Figure 15: IDD vs VDD, at TA= 25/55/85/105 °C, Run mode, code running from Flash memory, Range 2, HSI16, 1WS, Figure 16: IDD vs VDD, at TA= 25/55/ 85/105/125 °C, Low-power run mode, code running from RAM, Range 3, MSI (Range 0) at 64 KHz, 0 WS, Figure 17: IDD vs VDD, at TA= 25/55/ 85/105/125 °C, Stop mode with RTC enabled and running on LSE Low drive and Figure 18: IDD vs VDD, at TA= 25/55/85/105/125 °C, Stop mode with RTC disabled, all clocks off.</p> <p>Updated Table 42: HSE oscillator characteristics and Table 43: LSE oscillator characteristics. Added Figure 23: HSI16 minimum and maximum value versus temperature.</p> <p>Updated Table 53: ESD absolute maximum ratings, Table 55: I/O current injection susceptibility and Table 56: I/O static characteristics, and added Figure 24: VIH/VIL versus VDD (CMOS I/Os) and Figure 25: VIH/VIL versus VDD (TTL I/Os). Updated Table 57: Output voltage characteristics, Table 58: I/O AC characteristics and Figure 26: I/O AC characteristics definition.</p> <p>Updated Table 60: ADC characteristics, Table 62: ADC accuracy, and Figure 29: Typical connection diagram using the ADC. Updated Table 64: Temperature sensor characteristics.</p> <p>Updated Table 69: SPI characteristics in voltage Range 1 and Table 72: I2S characteristics.</p> <p>Added Figure 52: Thermal resistance.</p> |

Table 81. Document revision history (continued)

| Date | Revision | Changes |
|-------------|----------|---|
| 25-Jun-2014 | 3 | <p>Cover page: changed LQFP32 size, updated core speed. updated core speed, added minimum supply voltage for ADC and comparators. ADC now guaranteed down to 1.65 V.</p> <p>Updated list of applications in Section 1: Introduction. Changed number of I2S interfaces to one in Section 2: Description.</p> <p>Updated Table 2: Ultra-low-power STM32L051x6/x8 device features and peripheral counts.</p> <p>Updated Table 3: Functionalities depending on the operating power supply range.</p> <p>Updated RTC/TIM21 in Table 6: STM32L0xx peripherals interconnect matrix.</p> <p>Added note related to UFQFPN32 and note related to WLCSP36 in Table 15: STM32L051x6/8 pin definitions. Split LQFP32/UFQFPN32 pinout schematics into two distinct figures: Figure 4 and Figure 5.</p> <p>Updated V_{DDA} in Table 23: General operating conditions.</p> <p>Split Table <i>Current consumption in Run mode, code with data processing running from Flash</i> into Table 27 and Table 28 and content updated. Split Table <i>Current consumption in Run mode, code with data processing running from RAM</i> into Table 29 and Table 30 and content updated. Updated Table 31: Current consumption in Sleep mode, Table 32: Current consumption in Low-power Run mode, Table 33: Current consumption in Low-power Sleep mode, Table 34: Typical and maximum current consumptions in Stop mode, Table 35: Typical and maximum current consumptions in Standby mode, and added Table 36: Average current consumption during wakeup.</p> <p>Updated Table 37: Peripheral current consumption in run or Sleep mode and added Table 38: Peripheral current consumption in Stop and Standby mode.</p> <p>Updated t_{LOCK} in Table 47: PLL characteristics.</p> <p>Removed note 1 below Figure 21: HSE oscillator circuit diagram.</p> <p>Updated Table 49: Flash memory and data EEPROM characteristics and Table 50: Flash memory and data EEPROM endurance and retention.</p> <p>Updated Table 58: I/O AC characteristics.</p> <p>Updated Table 60: ADC characteristics.</p> <p>Updated Figure 52: Thermal resistance and added note 1.</p> |

Table 81. Document revision history (continued)

| Date | Revision | Changes |
|-------------|----------|--|
| 05-Sep-2104 | 4 | <p>Extended operating temperature range to 125 °C.</p> <p>Updated minimum ADC operating voltage to 1.65 V.</p> <p>Updated Section 3.4.1: Power supply schemes.</p> <p>Replaced USART3 by LPUART1 in Table 15: STM32L051x6/8 pin definitions and LPUART by LPUART1 in Table 16: Alternate function port A, Table 17: Alternate function port B, Table 18: Alternate function port C and Table 19: Alternate function port D.</p> <p>Updated temperature range in Section 2: Description, Table 2: Ultra-low-power STM32L051x6/x8 device features and peripheral counts.</p> <p>Updated P_D, T_A and T_J to add range 3 in Table 23: General operating conditions. Added range 3 in Table 50: Flash memory and data EEPROM endurance and retention, Table 80: STM32L051x6/8 ordering information scheme. Update note 1 in Table 27: Current consumption in Run mode, code with data processing running from Flash, Table 29: Current consumption in Run mode, code with data processing running from RAM, Table 31: Current consumption in Sleep mode, Table 32: Current consumption in Low-power Run mode, Table 33: Current consumption in Low-power Sleep mode, Table 34: Typical and maximum current consumptions in Stop mode, Table 35: Typical and maximum current consumptions in Standby mode and Table 39: Low-power mode wakeup timings. Updated Figure 52: Thermal resistance and removed note 1. Updated Table 60: ADC characteristics and Table 62: ADC accuracy.</p> <p>Updated Figure 16: IDD vs VDD, at TA= 25/55/ 85/105/125 °C, Low-power run mode, code running from RAM, Range 3, MSI (Range 0) at 64 KHz, 0 WS, Figure 17: IDD vs VDD, at TA= 25/55/ 85/105/125 °C, Stop mode with RTC enabled and running on LSE Low drive, Figure 18: IDD vs VDD, at TA= 25/55/85/105/125 °C, Stop mode with RTC disabled, all clocks off.</p> <p>Updated Table 35: Typical and maximum current consumptions in Standby mode.</p> <p>Updated SYSCFG in Table 37: Peripheral current consumption in run or Sleep mode.</p> <p>Updated Table 38: Peripheral current consumption in Stop and Standby mode and Table 39: Low-power mode wakeup timings.</p> <p>Updated ACC_{HSI16} temperature conditions in Table 44: 16 MHz HSI16 oscillator characteristics.</p> <p>Updated V_{F(NRST)} and V_{NF(NRST)} in Table 59: NRST pin characteristics.</p> <p>Updated Table 60: ADC characteristics and Table 62: ADC accuracy.</p> <p>Added range 3 in Table 80: STM32L051x6/8 ordering information scheme.</p> |

IMPORTANT NOTICE – PLEASE READ CAREFULLY

STMicroelectronics NV and its subsidiaries ("ST") reserve the right to make changes, corrections, enhancements, modifications, and improvements to ST products and/or to this document at any time without notice. Purchasers should obtain the latest relevant information on ST products before placing orders. ST products are sold pursuant to ST's terms and conditions of sale in place at the time of order acknowledgement.

Purchasers are solely responsible for the choice, selection, and use of ST products and ST assumes no liability for application assistance or the design of Purchasers' products.

No license, express or implied, to any intellectual property right is granted by ST herein.

Resale of ST products with provisions different from the information set forth herein shall void any warranty granted by ST for such product.

ST and the ST logo are trademarks of ST. All other product or service names are the property of their respective owners.

Information in this document supersedes and replaces information previously supplied in any prior versions of this document.

© 2014 STMicroelectronics – All rights reserved



AMEYA360

Components Supply Platform

Authorized Distribution Brand :



Website :

Welcome to visit www.ameya360.com

Contact Us :

➤ Address :

401 Building No.5, JiuGe Business Center, Lane 2301, Yishan Rd
Minhang District, Shanghai , China

➤ Sales :

Direct +86 (21) 6401-6692

Email amall@ameya360.com

QQ 800077892

Skype [ameyasales1](#) [ameyasales2](#)

➤ Customer Service :

Email service@ameya360.com

➤ Partnership :

Tel +86 (21) 64016692-8333

Email mkt@ameya360.com