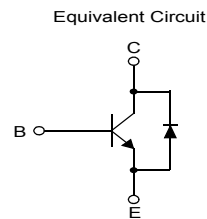
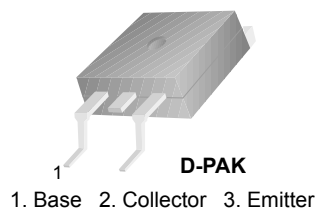


# FJD5304D

## High Voltage Fast Switching Transistor

### Features

- Built-in Free Wheeling Diode
- Wide Safe Operating Area
- Small Variance in Storage Time
- Suitable for Electronic Ballast Application



### Absolute Maximum Ratings $T_a = 25^\circ\text{C}$ unless otherwise noted

Symbol	Parameter	Value	Units	
$V_{CB0}$	Collector-Base Voltage	700	V	
$V_{CEO}$	Collector-Emitter Voltage	400	V	
$V_{EBO}$	Emitter-Base Voltage	12	V	
$I_C$	Collector Current (DC)	4	A	
$I_{CP}$	* Collector Current (Pulse)	8	A	
$I_B$	Base Current (DC)	2	A	
$I_{BP}$	* Base Current (Pulse)	4	A	
$P_C$	Collector Dissipation	$T_c = 25^\circ\text{C}$	30	W
		$T_a = 25^\circ\text{C}$	1.25	W
$T_J$	Junction Temperature	150	$^\circ\text{C}$	
$T_{STG}$	Storage Temperature	-55 to 150	$^\circ\text{C}$	

\* Pulse Test:  $PW = 300\mu\text{s}$ , Duty Cycle = 2% Pulsed

### Thermal Characteristics $T_a = 25^\circ\text{C}$ unless otherwise noted

Symbol	Parameter	Value	Units
$R_{\theta ja}$	Thermal Resistance Junction-Ambient **	99	$^\circ\text{C/W}$

\*\* Device mounted on minimum pad size.

## Package Marking and Ordering Information

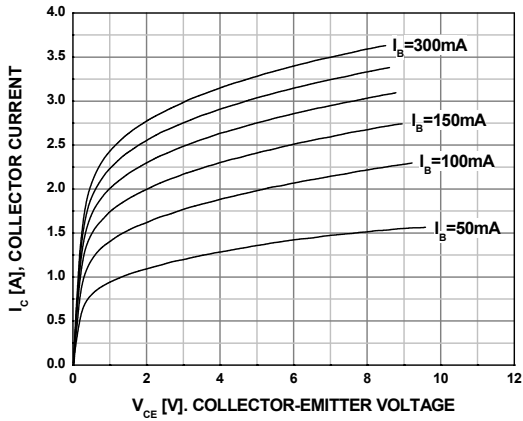
Device Marking	Device	Package	Reel Size	Tape Width	Quantity
J5304D	FJD5304DTM	D-PAK	13" Dia	-	2500
J5304D	FJD5304DTF	D-PAK	13" Dia	-	2000

## Electrical Characteristics $T_a = 25^\circ\text{C}$ unless otherwise noted

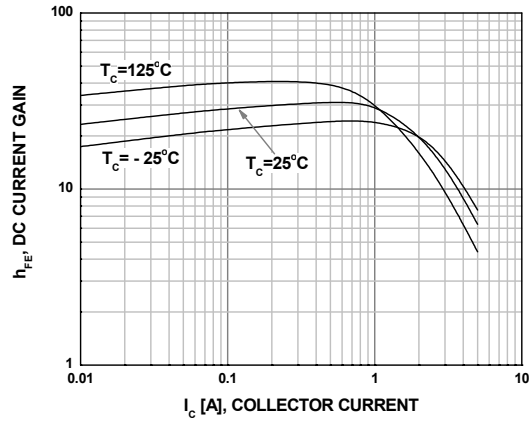
Symbol	Parameter	Conditions	Min.	Typ.	Max.	Units
$BV_{CBO}$	Collector-Base Breakdown Voltage	$I_C = 1\text{mA}, I_E = 0$	700			V
$BV_{CEO}$	Collector-Emitter Breakdown Voltage	$I_C = 5\text{mA}, I_B = 0$	400			V
$BV_{EBO}$	Emitter-Base Breakdown Voltage	$I_E = 1\text{mA}, I_C = 0$	12			V
$I_{CES}$	Collector Cut-off Current	$V_{CB} = 700\text{V}, I_E = 0$			100	$\mu\text{A}$
$I_{CEO}$	Collector Cut-off Current	$V_{CB} = 400\text{V}, I_B = 0$			250	$\mu\text{A}$
$I_{EBO}$	Emitter Cut-off Current	$V_{EB} = 12\text{V}, I_C = 0$			1	mA
$h_{FE}$	DC Current Gain	$V_{CE} = 5\text{V}, I_C = 10\text{mA}$ $V_{CE} = 5\text{V}, I_C = 2.0\text{A}$	10 8		40	
$V_{CE(sat)}$	Collector-Emitter Saturation Voltage	$I_C = 0.5\text{A}, I_B = 0.1\text{A}$			0.7	V
		$I_C = 1.0\text{A}, I_B = 0.2\text{A}$			1.0	V
		$I_C = 2.5\text{A}, I_B = 0.5\text{A}$			1.5	V
$V_{BE(sat)}$	Base-Emitter Saturation Voltage	$I_C = 0.5\text{A}, I_B = 0.1\text{A}$			1.1	V
		$I_C = 1.0\text{A}, I_B = 0.2\text{A}$			1.2	V
		$I_C = 2.5\text{A}, I_B = 0.5\text{A}$			1.3	V
$t_{STG}$	Storage Time	$V_{CLAMP}=200\text{V}, I_C=2.0\text{A},$ $I_{B1}=0.4\text{A}, V_{BE(off)}=-5\text{V}, L=200\mu\text{H}$		0.6		$\mu\text{s}$
$t_F$	Fall Time			0.1		$\mu\text{s}$
$t_{STG}$	Storage Time	$V_{CC}=250\text{V}, I_C=2.0\text{A},$ $I_{B1}=0.4\text{A}, I_{B2}=-0.4\text{A}, T_P=30\mu\text{s}$			2.9	$\mu\text{s}$
$t_F$	Fall Time			0.2		$\mu\text{s}$
$V_F$	Diode Forward Voltage	$I_F = 2\text{A}$			2.5	V

## Typical Performance Characteristics

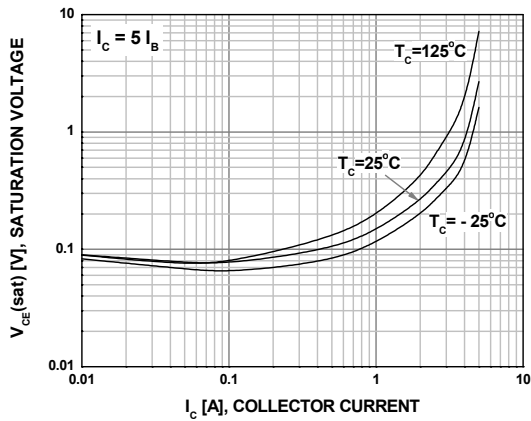
**Figure 1. Static Characteristic**



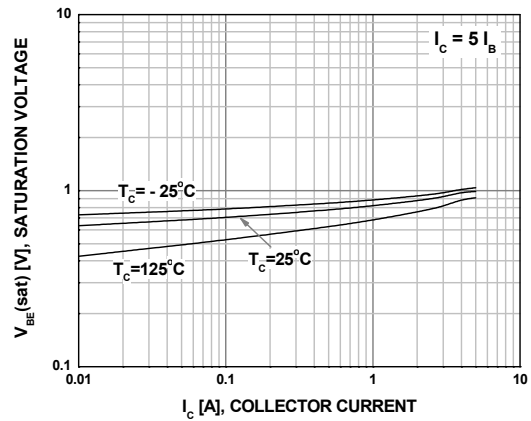
**Figure 2. DC Current Gain**



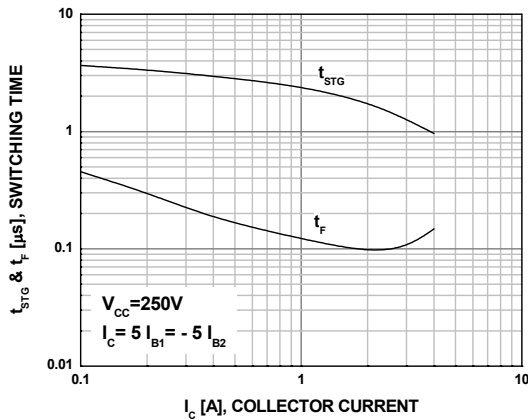
**Figure 3. Collector-Emitter Saturation Voltage**



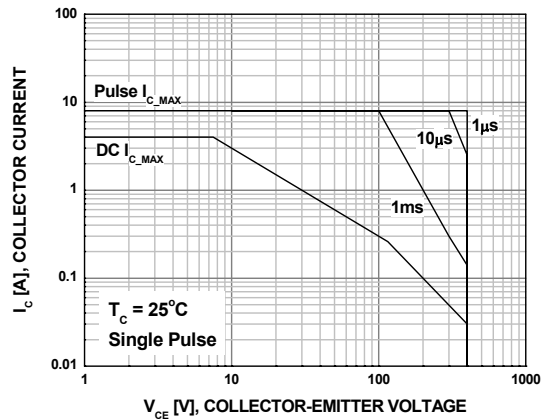
**Figure 4. Base-Emitter Saturation Voltage**



**Figure 5. Resistive Load Switching Time**

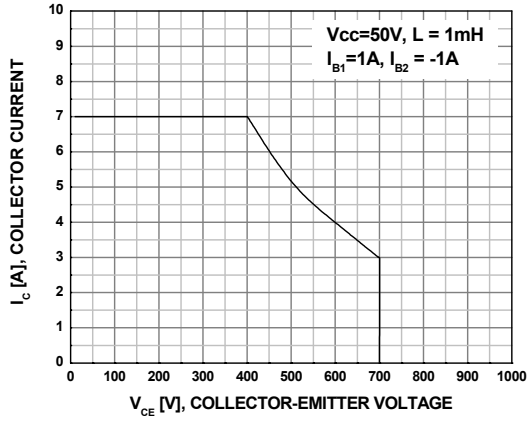


**Figure 6. Forward Biased Safe Operating Area**

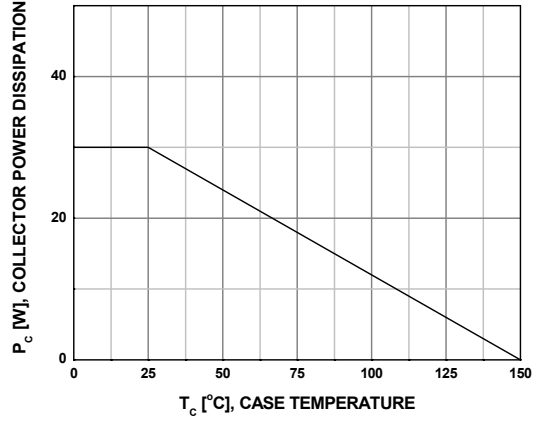


**Typical Performance Characteristics (Continued)**

**Figure 7. Reverse Biased Safe Operating Area**

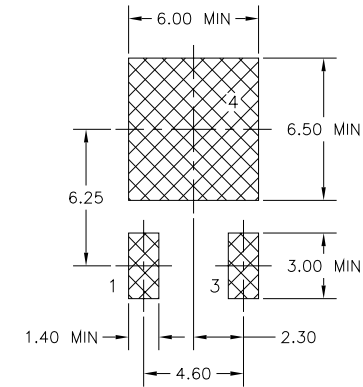
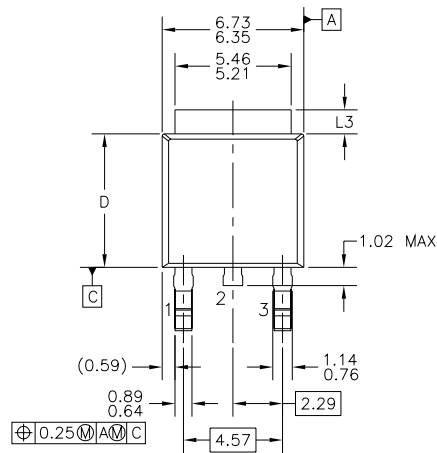


**Figure 8. Power Derating Curve**

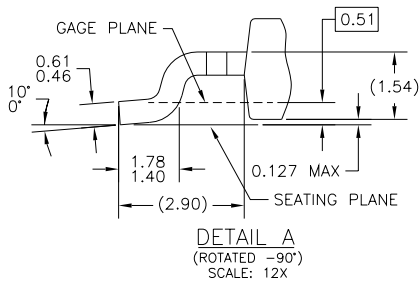
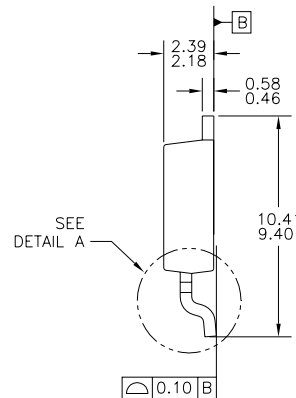
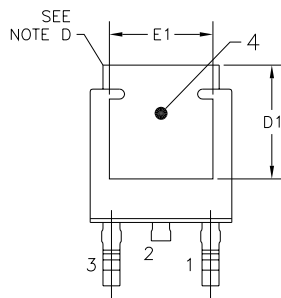


## Mechanical Dimensions

### D-PAK



LAND PATTERN RECOMMENDATION



- NOTES: UNLESS OTHERWISE SPECIFIED  
 A) ALL DIMENSIONS ARE IN MILLIMETERS.  
 B) THIS PACKAGE CONFORMS TO JEDEC, TO-252, ISSUE C, VARIATION AA & AB, DATED NOV. 1999.  
 C) DIMENSIONING AND TOLERANCING PER ASME Y14.5M-1994.  
 D) HEAT SINK TOP EDGE COULD BE IN CHAMFERED CORNERS OR EDGE PROTRUSION.  
 E) DIMENSIONS L3,D,E1&D1 TABLE:
- |    | OPTION AA | OPTION AB |
|----|-----------|-----------|
| L3 | 0.89-1.27 | 1.52-2.03 |
| D  | 5.97-6.22 | 5.33-5.59 |
| E1 | 4.32 MIN  | 3.81 MIN  |
| D1 | 5.21 MIN  | 4.57 MIN  |
- F) PRESENCE OF TRIMMED CENTER LEAD IS OPTIONAL.

Dimensions in Millimeters



**TRADEMARKS**

The following includes registered and unregistered trademarks and service marks, owned by Fairchild Semiconductor and/or its global subsidiaries, and is not intended to be an exhaustive list of all such trademarks.

AccuPower™	F-PFS™	Power-SPM™	<p>SYSTEM GENERAL® The Power Franchise® the power franchise TinyBoost™ TinyBuck™ TinyCalc™ TinyLogic® TINYOPTO™ TinyPower™ TinyPWM™ TinyWire™ TriFault Detect™ TRUECURRENT™* µSerDes™  SerDes® UHC® Ultra FRFET™ UniFET™ VCX™ VisualMax™ XS™</p>
Auto-SPM™	FRFET®	PowerTrench®	
Build it Now™	Global Power Resource <sup>SM</sup>	PowerXS™	
CorePLUS™	Green FPS™	Programmable Active Droop™	
CorePOWER™	Green FPS™ e-Series™	QFET®	
CROSSVOLT™	Gmax™	QS™	
CTL™	GTO™	Quiet Series™	
Current Transfer Logic™	IntelliMAX™	RapidConfigure™	
DEUXPEED®	ISOPLANAR™	™	
Dual Cool™	MegaBuck™	Saving our world, 1mW/W/kW at a time™	
EcoSPARK®	MICROCOUPLER™	SignalWise™	
EfficientMax™	MicroFET™	SmartMax™	
ESBC™	MicroPak™	SMART START™	
®	MicroPak2™	SPM®	
Fairchild®	MillerDrive™	STEALTH™	
Fairchild Semiconductor®	MotionMax™	SuperFET™	
FACT Quiet Series™	Motion-SPM™	SuperSOT™-3	
FACT®	OptoHiT™	SuperSOT™-6	
FAST®	OPTOLOGIC®	SuperSOT™-8	
FastvCore™	OPTOPLANAR®	SupreMOS®	
FETBench™	®	SyncFET™	
FlashWriter®*	PDP SPM™	Sync-Lock™	
FPS™			

\* Trademarks of System General Corporation, used under license by Fairchild Semiconductor.

**DISCLAIMER**

FAIRCHILD SEMICONDUCTOR RESERVES THE RIGHT TO MAKE CHANGES WITHOUT FURTHER NOTICE TO ANY PRODUCTS HEREIN TO IMPROVE RELIABILITY, FUNCTION, OR DESIGN. FAIRCHILD DOES NOT ASSUME ANY LIABILITY ARISING OUT OF THE APPLICATION OR USE OF ANY PRODUCT OR CIRCUIT DESCRIBED HEREIN; NEITHER DOES IT CONVEY ANY LICENSE UNDER ITS PATENT RIGHTS, NOR THE RIGHTS OF OTHERS. THESE SPECIFICATIONS DO NOT EXPAND THE TERMS OF FAIRCHILD'S WORLDWIDE TERMS AND CONDITIONS, SPECIFICALLY THE WARRANTY THEREIN, WHICH COVERS THESE PRODUCTS.

**LIFE SUPPORT POLICY**

FAIRCHILD'S PRODUCTS ARE NOT AUTHORIZED FOR USE AS CRITICAL COMPONENTS IN LIFE SUPPORT DEVICES OR SYSTEMS WITHOUT THE EXPRESS WRITTEN APPROVAL OF FAIRCHILD SEMICONDUCTOR CORPORATION.

As used herein:

1. Life support devices or systems are devices or systems which, (a) are intended for surgical implant into the body or (b) support or sustain life, and (c) whose failure to perform when properly used in accordance with instructions for use provided in the labeling, can be reasonably expected to result in a significant injury of the user.
2. A critical component in any component of a life support, device, or system whose failure to perform can be reasonably expected to cause the failure of the life support device or system, or to affect its safety or effectiveness.

**ANTI-COUNTERFEITING POLICY**

Fairchild Semiconductor Corporation's Anti-Counterfeiting Policy. Fairchild's Anti-Counterfeiting Policy is also stated on our external website, [www.fairchildsemi.com](http://www.fairchildsemi.com), under Sales Support.

Counterfeiting of semiconductor parts is a growing problem in the industry. All manufacturers of semiconductor products are experiencing counterfeiting of their parts. Customers who inadvertently purchase counterfeit parts experience many problems such as loss of brand reputation, substandard performance, failed applications, and increased cost of production and manufacturing delays. Fairchild is taking strong measures to protect ourselves and our customers from the proliferation of counterfeit parts. Fairchild strongly encourages customers to purchase Fairchild parts either directly from Fairchild or from Authorized Fairchild Distributors who are listed by country on our web page cited above. Products customers buy either from Fairchild directly or from Authorized Fairchild Distributors are genuine parts, have full traceability, meet Fairchild's quality standards for handling and storage and provide access to Fairchild's full range of up-to-date technical and product information. Fairchild and our Authorized Distributors will stand behind all warranties and will appropriately address any warranty issues that may arise. Fairchild will not provide any warranty coverage or other assistance for parts bought from Unauthorized Sources. Fairchild is committed to combat this global problem and encourage our customers to do their part in stopping this practice by buying direct or from authorized distributors.

**PRODUCT STATUS DEFINITIONS**

**Definition of Terms**

Datasheet Identification	Product Status	Definition
Advance Information	Formative / In Design	Datasheet contains the design specifications for product development. Specifications may change in any manner without notice.
Preliminary	First Production	Datasheet contains preliminary data; supplementary data will be published at a later date. Fairchild Semiconductor reserves the right to make changes at any time without notice to improve design.
No Identification Needed	Full Production	Datasheet contains final specifications. Fairchild Semiconductor reserves the right to make changes at any time without notice to improve the design.
Obsolete	Not In Production	Datasheet contains specifications on a product that is discontinued by Fairchild Semiconductor. The datasheet is for reference information only.

# AMEYA360

## Components Supply Platform

### Authorized Distribution Brand :



### Website :

Welcome to visit [www.ameya360.com](http://www.ameya360.com)

### Contact Us :

#### ➤ Address :

401 Building No.5, JiuGe Business Center, Lane 2301, Yishan Rd  
Minhang District, Shanghai , China

#### ➤ Sales :

Direct +86 (21) 6401-6692

Email [amall@ameya360.com](mailto:amall@ameya360.com)

QQ 800077892

Skype [ameyasales1](#) [ameyasales2](#)

#### ➤ Customer Service :

Email [service@ameya360.com](mailto:service@ameya360.com)

#### ➤ Partnership :

Tel +86 (21) 64016692-8333

Email [mkt@ameya360.com](mailto:mkt@ameya360.com)