

NB6HQ14M

2.5V 5GHz / 6.5Gbps Differential Input to 1.8V / 2.5V 1:4 CML Clock / Data Fanout Buffer w/ Selectable Input Equalizer

Multi-Level Inputs w/ Internal Termination

Description

The NB6HQ14M is a high performance differential 1:4 CML fanout buffer with a selectable Equalizer receiver. When placed in series with a Clock /Data path operating up to 5 GHz or 6.5 Gb/s, respectively, the NB6HQ14M inputs will compensate the degraded signal transmitted across a FR4 PCB backplane or cable interconnect and output four identical CML copies of the input signal. Therefore, the serial data rate is increased by reducing Inter-Symbol Interference (ISI) caused by losses in copper interconnect or long cables. The Equalizer Enable pin (EQEN) allows the IN/IN inputs to either flow through or bypass the Equalizer section. Control of the Equalizer function is realized by setting EQEN; When EQEN is set Low, the IN/IN inputs bypass the Equalizer. When EQEN is set High, the IN/IN inputs flow through the Equalizer. The default state at start-up is LOW. As such, NB6HQ14M is ideal for SONET, GigE, Fiber Channel, Backplane and other Clock/Data distribution applications.

The differential inputs incorporate internal 50 Ω termination resistors that are accessed through the VT pin. This feature allows the NB6HQ14M to accept various logic level standards, such as LVPECL, CML or LVDS. The outputs have the flexibility of being powered by either a 2.5 V or 1.8 V supply. The 1:4 fanout design was optimized for low output skew applications.

The NB6HQ14M is a member of the ECLinPS MAX™ family of high performance clock products.

Features

- Input Data Rate > 6.5 Gb/s
- Input Clock Frequency > 5 GHz
- 170 ps Typical Propagation Delay
- 35 ps Typical Rise and Fall Times
- < 15 ps Output Skew
- < 0.8 ps RMS Clock Jitter
- < 10 ps pp of Data Dependent Jitter
- Differential CML Outputs, 400 mV Peak-to-Peak, Typical
- Selectable Input Equalization
- Operating Range: $V_{CC} = 2.375 \text{ V}$ to 2.625 V , $V_{CCO} = 1.71 \text{ V}$ to 2.625 V
- Internal Input Termination Resistors, 50 Ω
- -40°C to $+85^{\circ}\text{C}$ Ambient Operating Temperature
- These are Pb-Free Devices



ON Semiconductor®

<http://onsemi.com>

MARKING DIAGRAM*

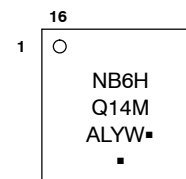

A	= Assembly Location
L	= Wafer Lot
Y	= Year
W	= Work Week
▪	= Pb-Free Package

(Note: Microdot may be in either location)

*For additional marking information, refer to Application Note AND8002/D.

SIMPLIFIED BLOCK DIAGRAM

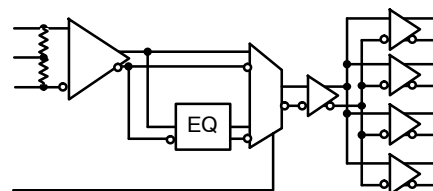

ORDERING INFORMATION

See detailed ordering and shipping information in the package dimensions section on page 10 of this data sheet.

NB6HQ14M

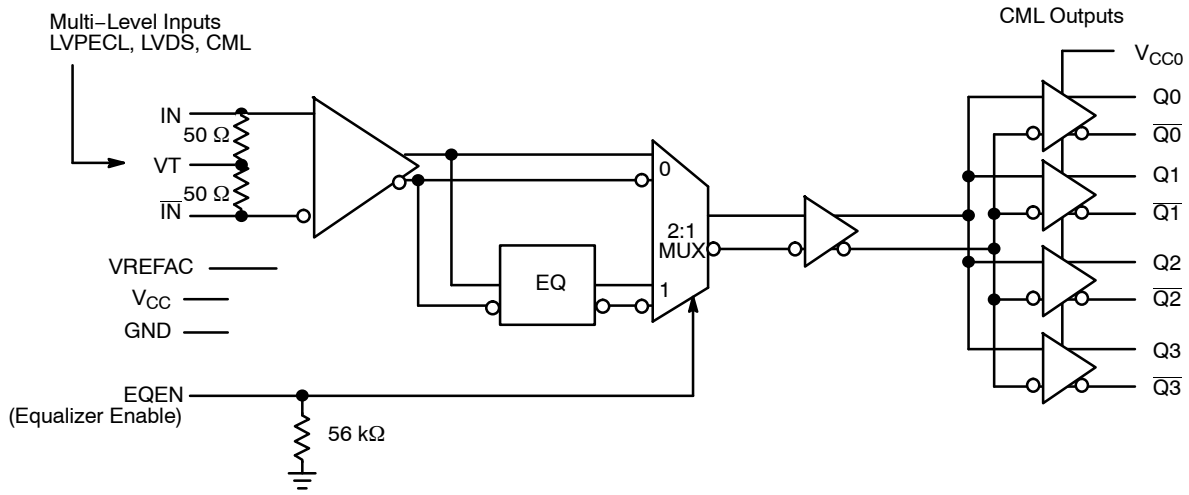

Figure 1. Detailed Block Diagram of NB6HQ14M

NB6HQ14M

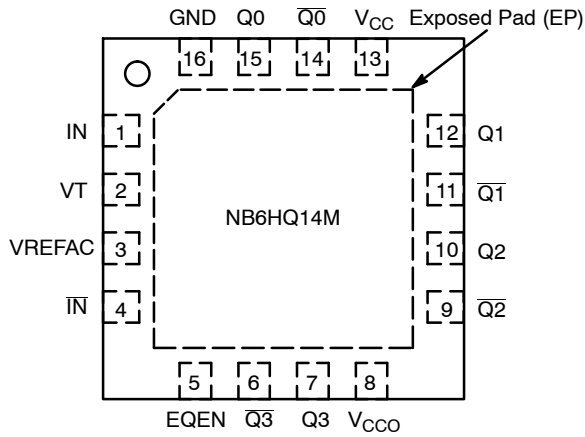

Figure 2. QFN-16 Pinout (Top View)

Table 1. EQUALIZER ENABLE FUNCTION

EQEN	Function
0	IN / $\overline{\text{IN}}$ Inputs By-pass the Equalizer section
1	Inputs flow through the Equalizer

Table 2. PIN DESCRIPTION

Pin	Name	I/O	Description
1	IN	LVPECL, CML, LVDS Input	Non-inverted Differential Input. Note 1.
2	VT		Internal 100 Ω Center-tapped Termination Pin for IN / $\overline{\text{IN}}$
3	VREFAC		Output Voltage Reference for Capacitor-Coupled Inputs, only
4	$\overline{\text{IN}}$	LVPECL, CML, LVDS Input	Inverted Differential Input. Note 1.
5	EQEN	LVCMOS Input	Equalizer Enable Input; pin will default LOW when left open (has internal pull-down resistor)
6	$\overline{\text{Q3}}$	CML Output	Inverted Differential Output. Typically Terminated with 50 Ω Resistor to V_{CC} .
7	Q3	CML Output	Non-inverted Differential Output. Typically Terminated with 50 Ω Resistor to V_{CC} .
8	VCCO	-	1.8 V or 2.5 V Positive Supply Voltage for the $\text{Q}_n / \overline{\text{Q}}_n$ CML Outputs
9	$\overline{\text{Q2}}$	CML Output	Inverted Differential Output. Typically Terminated with 50 Ω Resistor to V_{CC} .
10	Q2	CML Output	Non-inverted Differential Output. Typically Terminated with 50 Ω Resistor to V_{CC} .
11	$\overline{\text{Q1}}$	CML Output	Inverted Differential Output. Typically Terminated with 50 Ω Resistor to V_{CC} .
12	Q1	CML Output	Non-inverted Differential Output. Typically Terminated with 50 Ω Resistor to V_{CC} .
13	VCC	-	2.5 V Positive Supply Voltage for the core
14	$\overline{\text{Q0}}$	CML Output	Inverted Differential Output. Typically Terminated with 50 Ω Resistor to V_{CC} .
15	Q0	CML Output	Non-inverted Differential Output. Typically Terminated with 50 Ω Resistor to V_{CC} .
16	GND	-	Negative Supply Voltage
-	EP	-	The Exposed Pad (EP) on the QFN-16 package bottom is thermally connected to the die for improved heat transfer out of package. The exposed pad must be attached to a heat-sinking conduit. The pad is electrically connected to the die, and must be electrically and thermally connected to GND on the PC board.

1. In the differential configuration when the input termination pin (VT) is connected to a common termination voltage or left open, and if no signal is applied on IN / $\overline{\text{IN}}$ input, then, the device will be susceptible to self-oscillation.
2. All VCC, VCCO and GND pins must be externally connected to a power supply for proper operation.

NB6HQ14M

Table 3. ATTRIBUTES

Characteristics		Value
ESD Protection	Human Body Model Machine Model	> 2 kV > 200V
R _{PD} – EQEN Input Pulldown Resistor		56 kΩ
Moisture Sensitivity (Note 3)	16-QFN	Level 1
Flammability Rating	Oxygen Index: 28 to 34	UL 94 V-0 @ 0.125 in
Transistor Count		277
Meets or exceeds JEDEC Spec EIA/JESD78 IC Latchup Test		

3. For additional information, see Application Note AND8003/D.

Table 4. MAXIMUM RATINGS

Symbol	Parameter	Condition 1	Condition 2	Rating	Unit
V _{CC}	Positive Power Supply – Core	GND = 0 V		3.0	V
V _{CCO}	Positive Power Supply – Outputs	GND = 0 V		3.0	V
V _{IO}	Positive Input/Output Voltage	GND = 0 V		-0.5 to V _{CC} + 0.5	V
V _{INPP}	Differential Input Voltage I _N – I _N ̄			1.89	V
I _{IN}	Input Current Through R _T (50 Ω Resistor)			± 40	mA
I _{OUT}	Output Current Through R _T (50 Ω Resistor)			± 40	mA
I _{VFREFAC}	VREFAC Sink/Source Current			± 1.5	mA
T _A	Operating Temperature Range	16 QFN		-40 to +85	°C
T _{stg}	Storage Temperature Range			-65 to +150	°C
θ _{JA}	Thermal Resistance (Junction-to-Ambient) (Note 4)	0 lfpm 500 lfpm	16 QFN 16 QFN	42 35	°C/W °C/W
θ _{JC}	Thermal Resistance (Junction-to-Case) (Note 4)		16 QFN	4	°C/W
T _{sol}	Wave Solder Pb-Free			265	°C

Stresses exceeding Maximum Ratings may damage the device. Maximum Ratings are stress ratings only. Functional operation above the Recommended Operating Conditions is not implied. Extended exposure to stresses above the Recommended Operating Conditions may affect device reliability.

4. JEDEC standard multilayer board – 2S2P (2 signal, 2 power) with 8 filled thermal vias under exposed pad.

NB6HQ14M

Table 5. DC CHARACTERISTICS, MULTI-LEVEL INPUTS $V_{CC} = 2.375\text{ V to }2.625\text{ V}$; $V_{CCO} = 1.71\text{ V to }2.625\text{ V}$; $GND = 0\text{ V}$;
 $T_A = -40^\circ\text{C to }85^\circ\text{C}$ (Note 5)

Symbol	Characteristic	Min	Typ	Max	Unit
--------	----------------	-----	-----	-----	------

POWER SUPPLY / CURRENT

V_{CC} V_{CCO}	Power Supply Voltage	$V_{CC} = 2.5\text{ V}$ $V_{CCO} = 2.5\text{ V}$ $V_{CCO} = 1.8\text{ V}$	2.375 2.375 1.71	2.5 2.5 1.8	2.625 2.625 1.89	V
I_{CC} I_{CCO}	Power Supply Current for V_{CC} (Inputs and Outputs Open) Power Supply Current for V_{CCO} (Inputs and Outputs Open)			75 65	110 90	mA

CML OUTPUTS (Note 6)

V_{OH}	Output HIGH Voltage	$V_{CCO} = 2.5\text{ V}$ $V_{CCO} = 1.8\text{ V}$	$V_{CCO} - 30$ 2470 1770	$V_{CCO} - 10$ 2490 1790	V_{CCO} 2500 1800	mV
V_{OL}	Output LOW Voltage	$V_{CCO} = 2.5\text{ V}$ $V_{CCO} = 1.8\text{ V}$	$V_{CCO} - 550$ 1950 1250	$V_{CCO} - 450$ 2050 1350	$V_{CCO} - 300$ 2200 1500	mV

DIFFERENTIAL INPUT DRIVEN SINGLE-ENDED (see Figure 5 & 7) (Note 7)

V_{IH}	Single-ended Input HIGH Voltage		$V_{th} + 100$		V_{CC}	mV
V_{IL}	Single-ended Input LOW Voltage		GND		$V_{th} - 100$	mV
V_{th}	Input Threshold Reference Voltage Range (Note 8)		1100		$V_{CC} - 100$	mV
V_{ISE}	Single-ended Input Voltage Amplitude ($V_{IH} - V_{IL}$)		200		2800	mV

VREFAC

V_{REFAC}	Output Reference Voltage @100 μA for capacitor-coupled inputs, only		$V_{CC} - 1325$	$V_{CC} - 1125$	$V_{CC} - 925$	mV
-------------	--	--	-----------------	-----------------	----------------	----

DIFFERENTIAL INPUTS DRIVEN DIFFERENTIALLY (see Figure 6 & 8) (Note 9)

V_{IHD}	Differential Input HIGH Voltage		1200		V_{CC}	mV
V_{ILD}	Differential Input LOW Voltage		0		$V_{IHD} - 100$	mV
V_{ID}	Differential Input Voltage ($V_{IHD} - V_{ILD}$)		100		1200	mV
V_{CMR}	Input Common Mode Range (Differential Configuration) (Note 10) (Figure 9)		1050		$V_{CC} - 50$	mV
I_{IH}	Input HIGH Current I_N / \bar{I}_N , (VT Open)		-150		150	μA
I_{IL}	Input LOW Current I_N / \bar{I}_N , (VT Open)		-150		150	μA

CONTROL INPUTS (EQEN)

V_{IH}	Input HIGH Voltage for Control Pins		$V_{CC} \times 0.65$		V_{CC}	V
V_{IL}	Input LOW Voltage for Control Pins		GND		$V_{CC} \times 0.35$	V
I_{IH}	Input HIGH Current		-150		150	μA
I_{IL}	Input LOW Current		-150		150	μA

TERMINATION RESISTORS

R_{TIN}	Internal Input Termination Resistor		45	50	55	Ω
R_{TOUT}	Internal Output Termination Resistor		45	50	55	Ω

NOTE: Device will meet the specifications after thermal equilibrium has been established when mounted in a test socket or printed circuit board with maintained transverse airflow greater than 500 lfm. Electrical parameters are guaranteed only over the declared operating temperature range. Functional operation of the device exceeding these conditions is not implied. Device specification limit values are applied individually under normal operating conditions and not valid simultaneously.

- Input parameters vary 1:1 with V_{CC} . Output parameters vary 1:1 with V_{CCO} .
- CML outputs loaded with 50 Ω to V_{CCO} for proper operation.
- V_{th} , V_{IH} , V_{IL} , and V_{ISE} parameters must be complied with simultaneously.
- V_{th} is applied to the complementary input when operating in single-ended mode.
- V_{IHD} , V_{ILD} , V_{ID} and V_{CMR} parameters must be complied with simultaneously.
- V_{CMR} min varies 1:1 with GND, V_{CMR} max varies 1:1 with V_{CC} . The V_{CMR} range is referenced to the crosspoint side of the differential input signal.

NB6HQ14M

Table 6. AC CHARACTERISTICS $V_{CC} = 2.375\text{ V to }2.625\text{ V}$; $V_{CC0} = 1.71\text{ V to }2.625\text{ V}$; $GND = 0\text{ V}$; $T_A = -40^\circ\text{C to }85^\circ\text{C}$ (Note 11)

Symbol	Characteristic	Min	Typ	Max	Unit
f_{MAX}	Maximum Input Clock Frequency; $V_{OUT} \geq 200\text{ mV}$	5	7		GHz
$f_{DATAMAX}$	Maximum Operating Data Rate (PRBS23)	6.5	10		Gbps
V_{OUTPP}	Output Voltage Amplitude, EQEN = 0 or 1 (Note 15) (See Figures 3 and 10) $f_{in} \leq 5\text{ GHz}$	200	400		mV
t_{PLH} , t_{PHL}	Propagation Delay, EQEN = 0 or 1 IN to Q	150	220	275	ps
t_{SKEW}	Duty Cycle Skew (Note 12) Output – Output Within Device Skew Device to Device Skew		3 10	15 15 50	ps
t_{DC}	Output Clock Duty Cycle (Reference Duty Cycle = 50%) $f_{in} = 1\text{ GHz}$	45	50	55	%
Φ_N	Phase Noise, $f_{in} = 1\text{ GHz}$		-132 -135 -145 -146 -147 -148		dBc
$t_{J\Phi N}$	Integrated Phase Jitter $f_{in} = 1\text{ GHz}$, 12 kHz – 20 MHz Offset (RMS)		50		fs
t_{JITTER}	RMS Random Clock Jitter (Note 13) $f_{in} \leq 5\text{ GHz}$ Peak-to-Peak Data Dependent Jitter (Note 14) $f_{in} \leq 3.0\text{ Gb/s}$ EQEN = 0 ($\leq 3''\text{ FR4}$) EQEN = 1 ($12''\text{ FR4}$)		0.2	0.8 15 10	ps rms ps pk-pk ps pk-pk
V_{INPP}	Input Voltage Swing/Sensitivity (Differential Configuration) (Note 15)	100		1200	mV
t_r t_f	Output Rise/Fall Times @ 1.0 GHz (20% – 80%) Qx, \bar{Qx}	15	30	60	ps

NOTE: Device will meet the specifications after thermal equilibrium has been established when mounted in a test socket or printed circuit board with maintained transverse airflow greater than 500 lfm. Electrical parameters are guaranteed only over the declared operating temperature range. Functional operation of the device exceeding these conditions is not implied. Device specification limit values are applied individually under normal operating conditions and not valid simultaneously.

11. Measured by forcing V_{INPP} min from a 50% duty cycle clock source. All loading with an external $R_L = 50\ \Omega$ to V_{CC0} . Input edge rates 40 ps (20% – 80%).
12. Skew is measured between outputs under identical transitions and conditions @ 0.5 GHz. Duty cycle skew is measured between differential outputs using the deviations of the sum of T_{pw-} and T_{pw+} @ 0.5 GHz.
13. Additive RMS jitter with 50% duty cycle clock signal.
14. Additive peak-to-peak data dependent jitter with input NRZ data at PRBS23. For applications requiring equalization, the vertical eye height is also a critical figure of merit. See Figure 4 for equalized eye height versus data rate.
15. Input and output voltage swings are single-ended measurements operating in a differential mode.

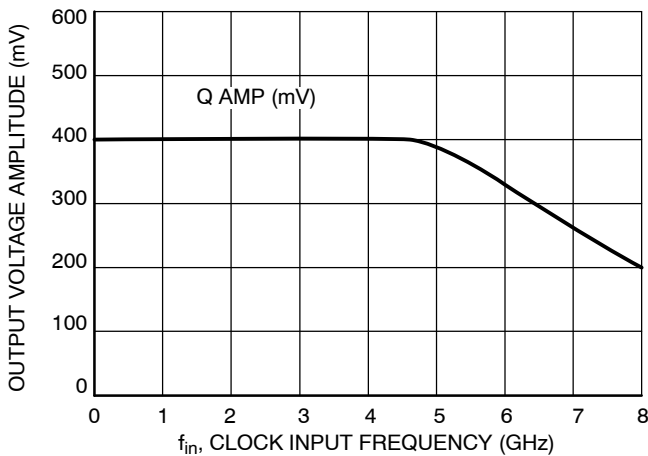

Figure 3. CLOCK Output Voltage Amplitude (V_{OUTPP}) vs. Input Frequency (f_{in}) at Ambient Temperature (Typical)

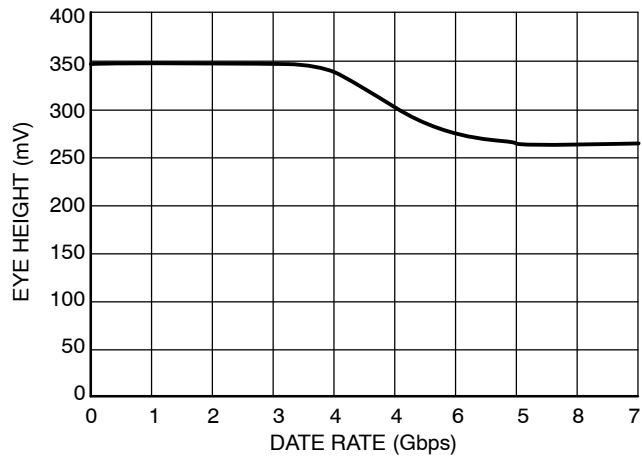

Figure 4. NB6HQ14M Eye Height vs. Data Rate

NB6HQ14M

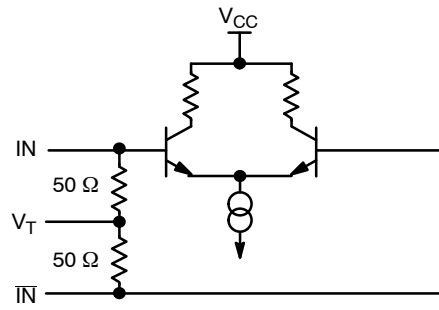

Figure 5. Input Structure

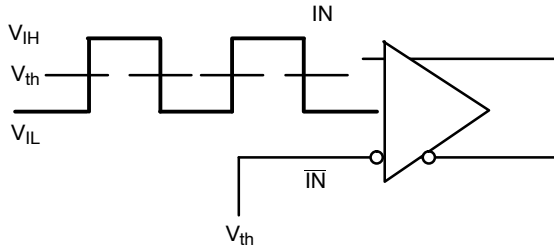

Figure 6. Differential Input Driven Single-Ended

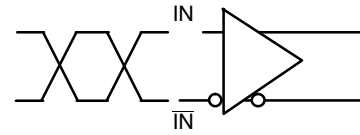

Figure 7. Differential Inputs Driven Differentially

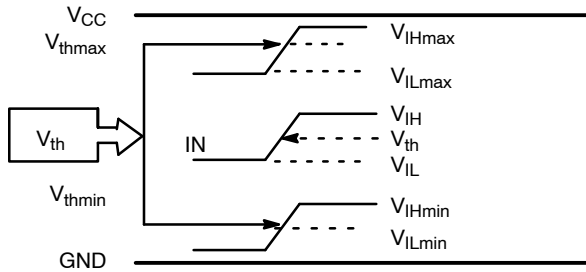

Figure 8. V_{th} Diagram

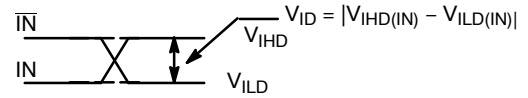

Figure 9. Differential Inputs Driven Differentially

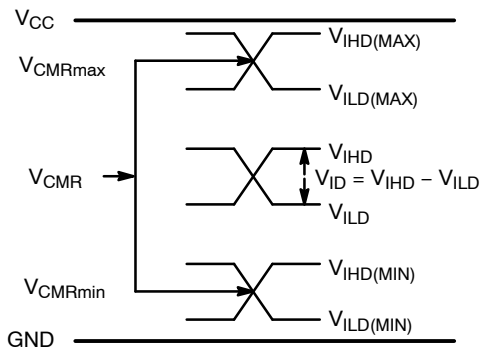

Figure 10. V_{CMR} Diagram

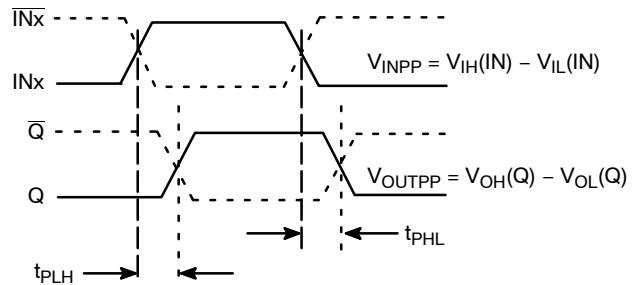

Figure 11. AC Reference Measurement

NB6HQ14M

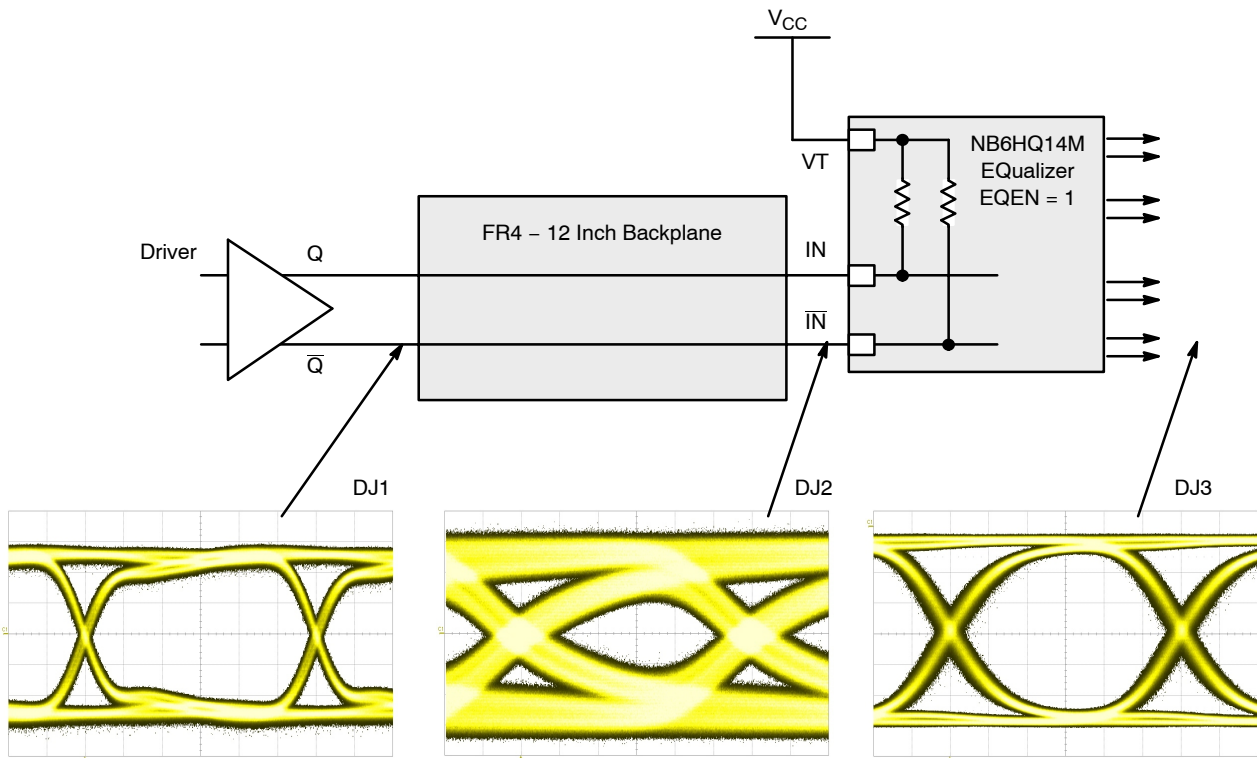

Figure 12. Typical NB6HQ14M Equalizer Application and Interconnect with PRBS23 pattern at 6.5 Gbps, EQEN = 1

NB6HQ14M

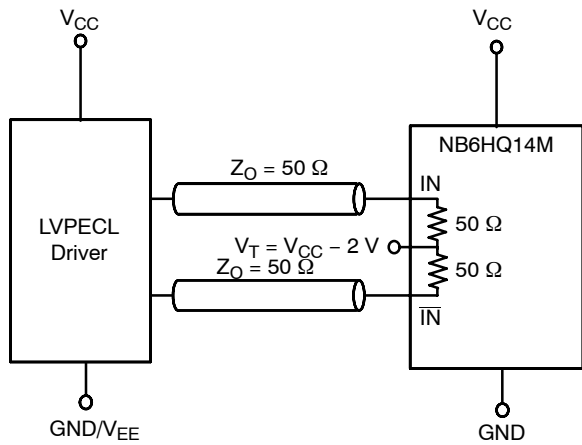

Figure 13. LVPECL Interface

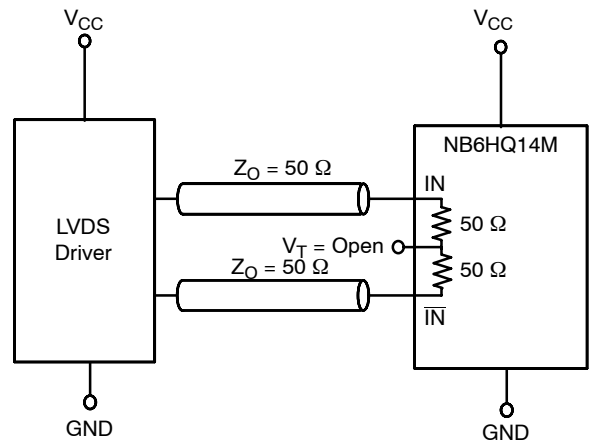

Figure 14. LVDS Interface

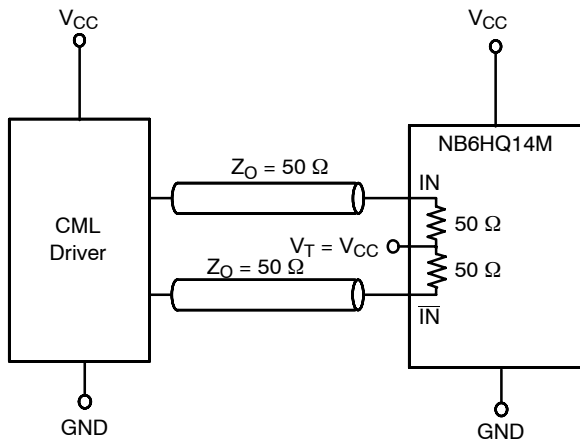

Figure 15. Standard 50 Ω Load CML Interface

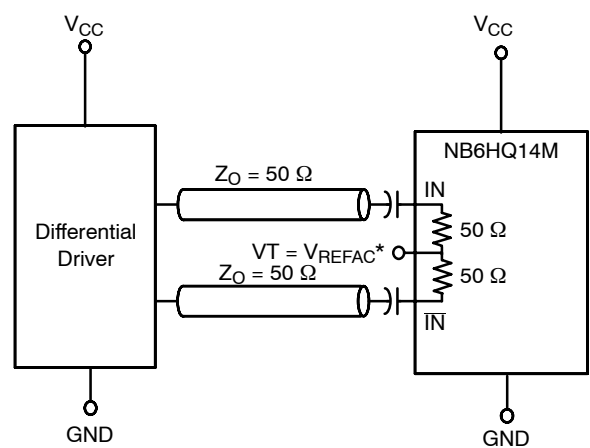

Figure 16. Capacitor-Coupled
Differential Interface
(V_T Connected to V_{REFAC})

* V_{REFAC} bypassed to ground with a 0.01 μ F capacitor

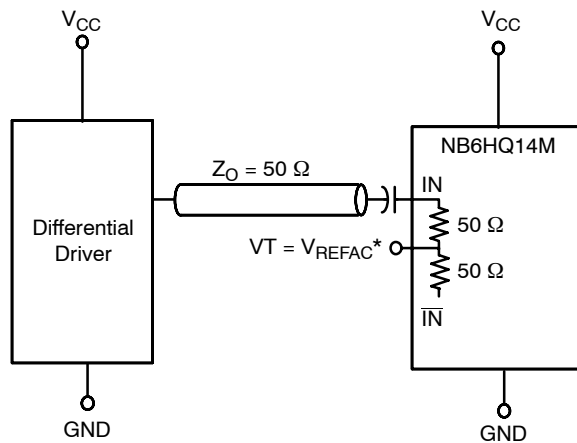

Figure 17. Capacitor-Coupled
Single-Ended Interface
(V_T Connected to V_{REFAC})

NB6HQ14M

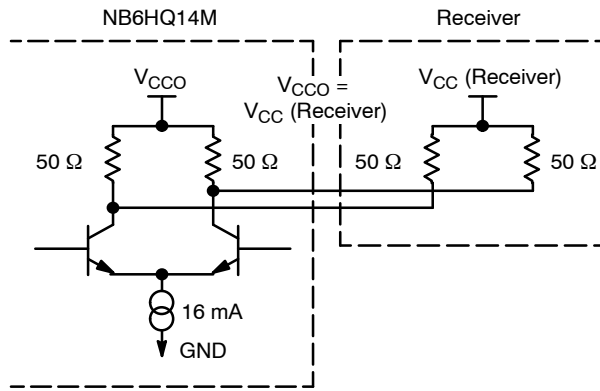

Figure 18. Typical CML Output Structure and Termination

ORDERING INFORMATION

Device	Package	Shipping [†]
NB6HQ14MMNG	QFN-16 (Pb-Free)	123 Units / Rail
NB6HQ14MMNHTBG	QFN-16 (Pb-Free)	100 / Tape & Reel
NB6HQ14MMNTXG	QFN-16 (Pb-Free)	3000 / Tape & Reel

[†]For information on tape and reel specifications, including part orientation and tape sizes, please refer to our Tape and Reel Packaging Specifications Brochure, BRD8011/D.

NB6HQ14M

PACKAGE DIMENSIONS

16 PIN QFN
CASE 485G-01
ISSUE D

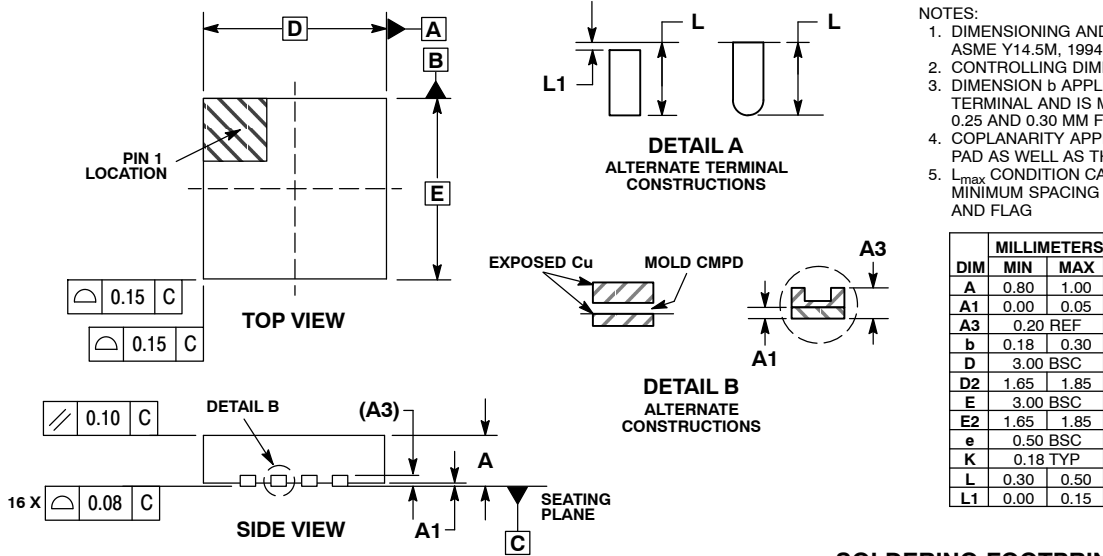

- NOTES:
1. DIMENSIONING AND TOLERANCING PER ASME Y14.5M, 1994.
 2. CONTROLLING DIMENSION: MILLIMETERS.
 3. DIMENSION b APPLIES TO PLATED TERMINAL AND IS MEASURED BETWEEN 0.25 AND 0.30 MM FROM TERMINAL.
 4. COPLANARITY APPLIES TO THE EXPOSED PAD AS WELL AS THE TERMINALS.
 5. L_{max} CONDITION CAN NOT VIOLATE 0.2 MM MINIMUM SPACING BETWEEN LEAD TIP AND FLAG

SOLDERING FOOTPRINT*

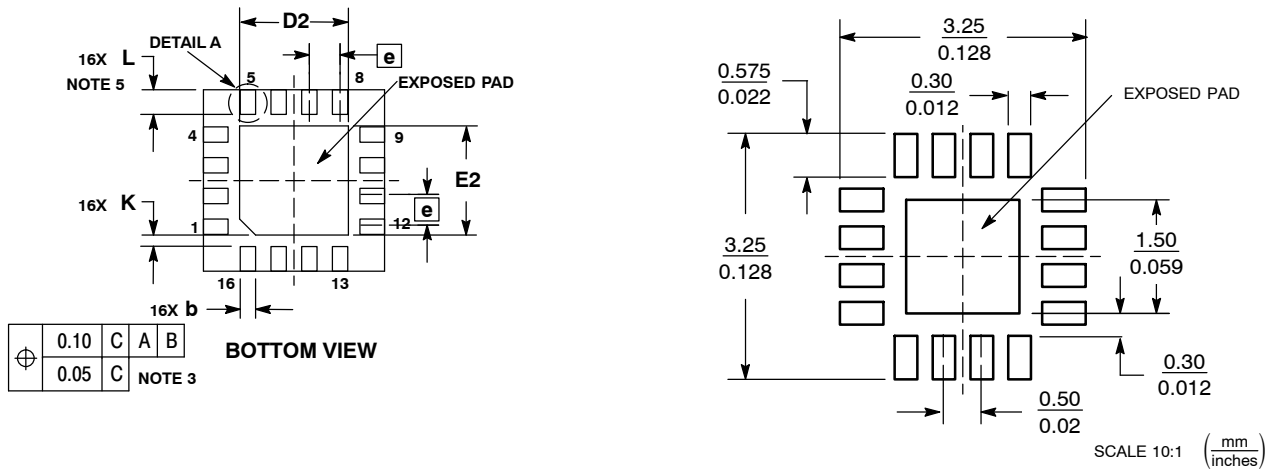

*For additional information on our Pb-Free strategy and soldering details, please download the ON Semiconductor Soldering and Mounting Techniques Reference Manual, SOLDERRM/D.

ECLinPS MAX is a trademark of Semiconductor Components Industries, LLC (SCILLC).

ON Semiconductor and are registered trademarks of Semiconductor Components Industries, LLC (SCILLC). SCILLC reserves the right to make changes without further notice to any products herein. SCILLC makes no warranty, representation or guarantee regarding the suitability of its products for any particular purpose, nor does SCILLC assume any liability arising out of the application or use of any product or circuit, and specifically disclaims any and all liability, including without limitation special, consequential or incidental damages. "Typical" parameters which may be provided in SCILLC data sheets and/or specifications can and do vary in different applications and actual performance may vary over time. All operating parameters, including "Typicals" must be validated for each customer application by customer's technical experts. SCILLC does not convey any license under its patent rights nor the rights of others. SCILLC products are not designed, intended, or authorized for use as components in systems intended for surgical implant into the body, or other applications intended to support or sustain life, or for any other application in which the failure of the SCILLC product could create a situation where personal injury or death may occur. Should Buyer purchase or use SCILLC products for any such unintended or unauthorized application, Buyer shall indemnify and hold SCILLC and its officers, employees, subsidiaries, affiliates, and distributors harmless against all claims, costs, damages, and expenses, and reasonable attorney fees arising out of, directly or indirectly, any claim of personal injury or death associated with such unintended or unauthorized use, even if such claim alleges that SCILLC was negligent regarding the design or manufacture of the part. SCILLC is an Equal Opportunity/Affirmative Action Employer. This literature is subject to all applicable copyright laws and is not for resale in any manner.

PUBLICATION ORDERING INFORMATION

LITERATURE FULFILLMENT:
Literature Distribution Center for ON Semiconductor
P.O. Box 5163, Denver, Colorado 80217 USA
Phone: 303-675-2175 or 800-344-3860 Toll Free USA/Canada
Fax: 303-675-2176 or 800-344-3867 Toll Free USA/Canada
Email: orderlit@onsemi.com

N. American Technical Support: 800-282-9855 Toll Free USA/Canada
Europe, Middle East and Africa Technical Support:
Phone: 421 33 790 2910
Japan Customer Focus Center
Phone: 81-3-5773-3850

ON Semiconductor Website: www.onsemi.com
Order Literature: <http://www.onsemi.com/orderlit>
For additional information, please contact your local Sales Representative

NB6HQ14M/D

AMEYA360

Components Supply Platform

Authorized Distribution Brand :



Website :

Welcome to visit www.ameya360.com

Contact Us :

➤ Address :

401 Building No.5, JiuGe Business Center, Lane 2301, Yishan Rd
Minhang District, Shanghai , China

➤ Sales :

Direct +86 (21) 6401-6692

Email amall@ameya360.com

QQ 800077892

Skype [ameyasales1](#) [ameyasales2](#)

➤ Customer Service :

Email service@ameya360.com

➤ Partnership :

Tel +86 (21) 64016692-8333

Email mkt@ameya360.com