



RF Power LDMOS Transistors

N-Channel Enhancement-Mode Lateral MOSFETs

These 22 watt symmetrical Doherty RF power LDMOS transistors are designed for cellular base station applications requiring very wide instantaneous bandwidth capability covering the frequency range of 2496 to 2690 MHz.

- Typical Doherty Single-Carrier W-CDMA Characterization Performance:
 $V_{DD} = 28$ Volts, $V_{GSA} = 0.4$ Vdc, $I_{DQB} = 344$ mA, $P_{out} = 22$ Watts Avg.,
 Input Signal PAR = 9.9 dB @ 0.01% Probability on CCDF.⁽¹⁾

Frequency	G_{ps} (dB)	η_D (%)	Output PAR (dB)	ACPR (dBc)	IRL (dB)
2496 MHz	15.5	44.4	8.0	-32.3	-15
2590 MHz	16.1	43.5	7.8	-34.9	-14
2690 MHz	15.3	43.9	7.4	-35.0	-13

Features

- Designed for Wide Instantaneous Bandwidth Applications
- Greater Negative Gate-Source Voltage Range for Improved Class C Operation
- Able to Withstand Extremely High Output VSWR and Broadband Operating Conditions
- In Tape and Reel. R3 Suffix = 250 Units, 32 mm Tape Width, 13-inch Reel.

AFT26P100-4WSR3
AFT26P100-4WGSR3

2496-2690 MHz, 22 W AVG., 28 V
AIRFAST RF POWER LDMOS
TRANSISTORS

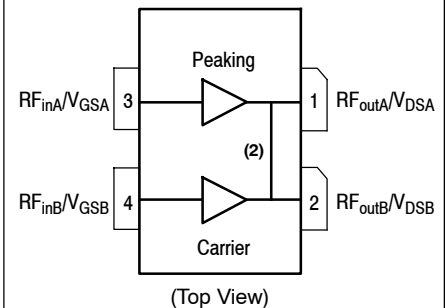
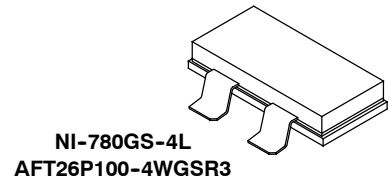

Figure 1. Pin Connections

2. Pin connections 1 and 2 are DC coupled and RF independent.

1. All characterization data measured in characterization fixture with device soldered to heatsink.

Table 1. Maximum Ratings

Rating	Symbol	Value	Unit
Drain-Source Voltage	V_{DS}	-0.5, +65	Vdc
Gate-Source Voltage	V_{GS}	-6.0, +10	Vdc
Operating Voltage	V_{DD}	32, +0	Vdc
Storage Temperature Range	T_{stg}	-65 to +150	°C
Case Operating Temperature Range	T_C	-40 to +125	°C
Operating Junction Temperature Range (1,2)	T_J	-40 to +225	°C
CW Operation @ $T_C = 25^\circ\text{C}$ Derate above 25°C	CW	195 2.60	W W/°C

Table 2. Thermal Characteristics

Characteristic	Symbol	Value (2,3)	Unit
Thermal Resistance, Junction to Case Case Temperature 77°C , 22 W CW, 28 Vdc, $V_{GSA} = 0.7$ Vdc, $I_{DQB} = 200$ mA, 2590 MHz	$R_{\theta JC}$	0.60	°C/W

Table 3. ESD Protection Characteristics

Test Methodology	Class
Human Body Model (per JESD22-A114)	2
Machine Model (per EIA/JESD22-A115)	B
Charge Device Model (per JESD22-C101)	III

Table 4. Electrical Characteristics ($T_A = 25^\circ\text{C}$ unless otherwise noted)

Characteristic	Symbol	Min	Typ	Max	Unit
----------------	--------	-----	-----	-----	------

Off Characteristics (4)

Zero Gate Voltage Drain Leakage Current ($V_{DS} = 65$ Vdc, $V_{GS} = 0$ Vdc)	I_{DSS}	—	—	10	μA dc
Zero Gate Voltage Drain Leakage Current ($V_{DS} = 28$ Vdc, $V_{GS} = 0$ Vdc)	I_{DSS}	—	—	5	μA dc
Gate-Source Leakage Current ($V_{GS} = 5$ Vdc, $V_{DS} = 0$ Vdc)	I_{GSS}	—	—	1	μA dc

On Characteristics

Gate Threshold Voltage (5) ($V_{DS} = 10$ Vdc, $I_D = 140$ μA dc)	$V_{GS(th)}$	0.8	1.2	1.6	Vdc
Gate Quiescent Voltage ($V_{DD} = 28$ Vdc, $I_{DB} = 200$ mA, Measured in Functional Test)	$V_{GSB(Q)}$	1.3	1.8	2.1	Vdc
Drain-Source On-Voltage (4) ($V_{GS} = 6$ Vdc, $I_D = 1.4$ A dc)	$V_{DS(on)}$	0.1	0.15	0.3	Vdc

1. Continuous use at maximum temperature will affect MTTF.
2. MTTF calculator available at <http://www.freescale.com/rf>. Select Software & Tools/Development Tools/Calculators to access MTTF calculators by product.
3. Refer to AN1955, *Thermal Measurement Methodology of RF Power Amplifiers*. Go to <http://www.freescale.com/rf>. Select Documentation/Application Notes - AN1955.
4. Measurement made with both sides of the transistor tied together.
5. Each side of device measured separately.

(continued)

Table 4. Electrical Characteristics ($T_A = 25^\circ\text{C}$ unless otherwise noted) (continued)

Characteristic	Symbol	Min	Typ	Max	Unit
Functional Tests (1,2,3,4) (In Freescale Doherty Production Test Fixture, 50 ohm system) $V_{DD} = 28\text{ Vdc}$, $V_{GSA} = 0.7\text{ Vdc}$, $I_{DQB} = 200\text{ mA}$, $P_{out} = 22\text{ W Avg.}$, $f = 2690\text{ MHz}$, Single-Carrier W-CDMA, IQ Magnitude Clipping, Input Signal PAR = 9.9 dB @ 0.01% Probability on CCDF. ACPR measured in 3.84 MHz Channel Bandwidth @ $\pm 5\text{ MHz}$ Offset.					
Power Gain	G_{ps}	14.4	15.1	17.4	dB
Drain Efficiency	η_D	39.0	41.0	—	%
Output Peak-to-Average Ratio @ 0.01% Probability on CCDF	PAR	6.8	7.4	—	dB
Adjacent Channel Power Ratio	ACPR	—	-33.8	-30.0	dBc
Input Return Loss	IRL	—	-17	-10	dB

Load Mismatch (In Freescale Production Test Fixture, 50 ohm system) $I_{DQB} = 200\text{ mA}$, $f = 2590\text{ MHz}$

VSWR 10:1 at 32 Vdc, 125 W CW Output Power (3 dB Input Overdrive from 100 W CW Rated Power)	No Device Degradation
--	-----------------------

Typical Performances (3,5) (In Freescale Doherty Characterization Test Fixture, 50 ohm system) $V_{DD} = 28\text{ Vdc}$, $V_{GSA} = 0.4\text{ Vdc}$, $I_{DQB} = 344\text{ mA}$, 2496-2690 MHz Bandwidth

P_{out} @ 1 dB Compression Point, CW	P1dB	—	87	—	W
P_{out} @ 3 dB Compression Point (6)	P3dB	—	125	—	W
AM/PM (Maximum value measured at the P3dB compression point across the 2496-2690 MHz frequency range)	Φ	—	18	—	$^\circ$
VBW Resonance Point (IMD Third Order Intermodulation Inflection Point)	VBW_{res}	—	150	—	MHz
Gain Flatness in 194 MHz Bandwidth @ $P_{out} = 22\text{ W Avg.}$	G_F	—	0.2	—	dB
Gain Variation over Temperature (-30°C to $+85^\circ\text{C}$)	ΔG	—	0.01	—	dB/ $^\circ\text{C}$
Output Power Variation over Temperature (-30°C to $+85^\circ\text{C}$) (7)	$\Delta P1dB$	—	0.01	—	dB/ $^\circ\text{C}$

1. V_{DDA} and V_{DDB} must be tied together and powered by a single DC power supply.
2. Part internally matched both on input and output.
3. Measurement made with device in a symmetrical Doherty configuration.
4. Measurements made with device in straight lead configuration before any lead forming operation is applied. Lead forming is used for gull wing (GS) parts.
5. All characterization data measured in characterization fixture with device soldered to heatsink.
6. $P3dB = P_{avg} + 7.0\text{ dB}$ where P_{avg} is the average output power measured using an unclipped W-CDMA single-carrier input signal where output PAR is compressed to 7.0 dB @ 0.01% probability on CCDF.
7. Exceeds recommended operating conditions. See CW operation data in Maximum Ratings table.

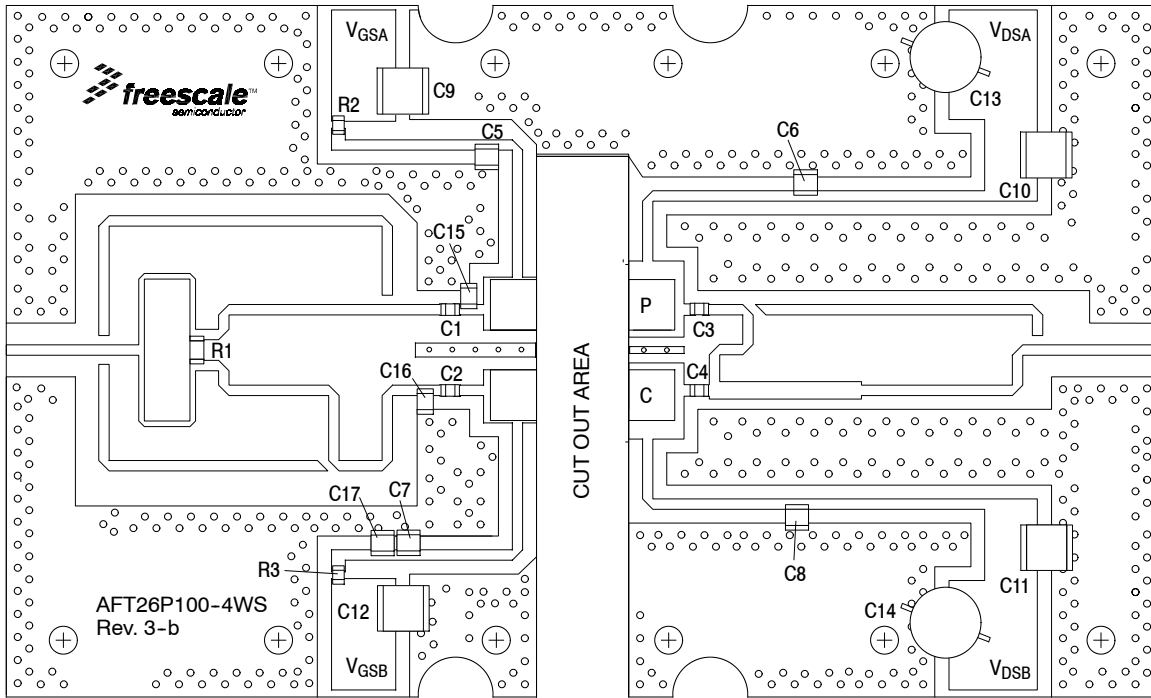

NOTE: V_{DDA} and V_{ddb} must be tied together and powered by a single DC power supply.

Figure 2. AFT26P100-4WSR3 Production Test Circuit Component Layout

Table 5. AFT26P100-4WSR3 Production Test Circuit Component Designations and Values

Part	Description	Part Number	Manufacturer
C1, C2	8.2 pF Chip Capacitors	ATC600F8R2BT250XT	ATC
C3	6.8 pF Chip Capacitor	ATC600F6R8BT250XT	ATC
C4	4.3 pF Chip Capacitor	ATC600F4R3BT250XT	ATC
C5, C6, C7, C8, C17	4.3 pF Chip Capacitors	ATC100B4R3CT500XT	ATC
C9, C10, C11, C12	10 μ F Chip Capacitors	GRM55DR61H106KA88L	Murata
C13, C14	470 μ F, 63 V Electrolytic Capacitors	MCGPR63V477M13X26-RH	Multicomp
C15	0.5 pF Chip Capacitor	ATC800B0R5BT500XT	ATC
C16	0.3 pF Chip Capacitor	ATC800B0R3BT500XT	ATC
R1	100 Ω , 1/4 W Chip Resistor	CRCW1206100RFKEA	Vishay
R2, R3	5.1 Ω , 1/10 W Chip Resistors	CRCW08055R10JNEA	Vishay
PCB	0.020", $\epsilon_r = 3.5$	RO4350B	Rogers

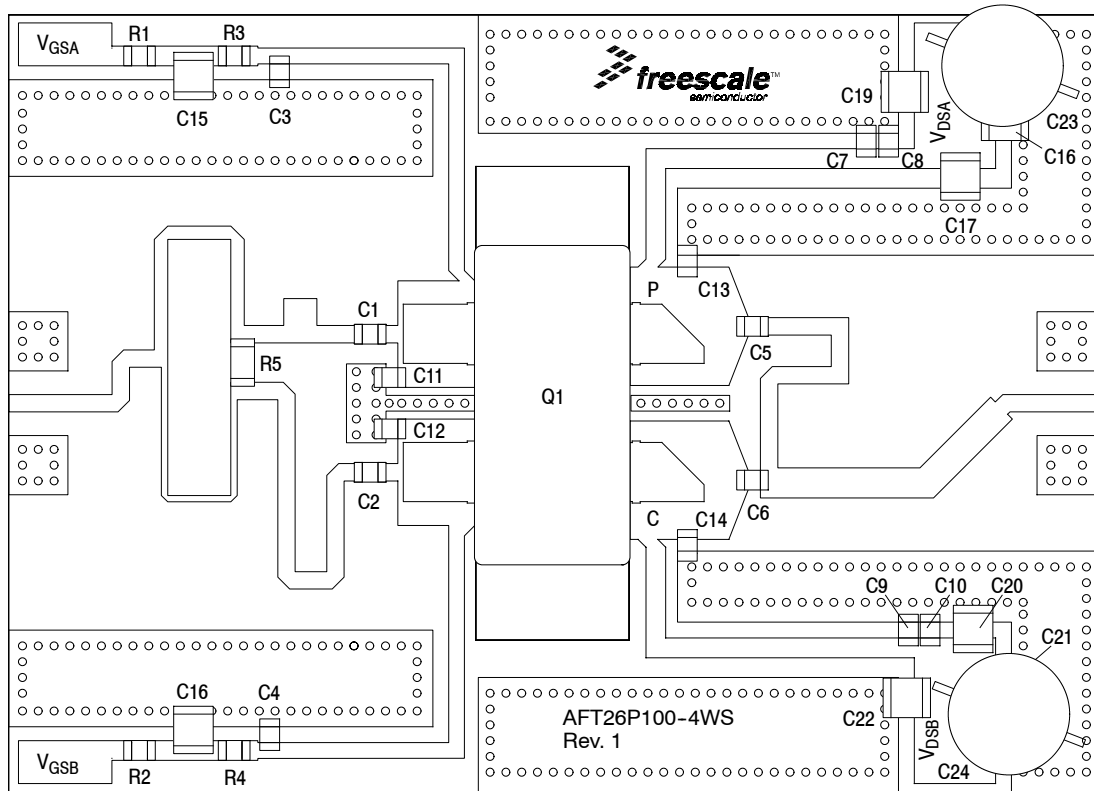

NOTE 1: All characterization data measured in characterization fixture with device soldered to heatsink.
 NOTE 2: V_{DDA} and V_{DDB} must be tied together and powered by a single DC power supply.

Figure 3. AFT26P100-4WSR3 Characterization Test Circuit Component Layout

Table 6. AFT26P100-4WSR3 Characterization Test Circuit Component Designations and Values

Part	Description	Part Number	Manufacturer
C1, C2, C3, C4, C5, C6, C7, C8, C9, C10	6.8 pF Chip Capacitors	ATC600F6R8BT250XT	ATC
C11, C12, C13, C14	0.2 pF Chip Capacitors	ATC600F0R2BT250XT	ATC
C15, C16, C17, C18, C19, C20, C21, C22	10 μ F, 50 V Chip Capacitors	GRM32ER61H106KA12L	Murata
C23, C24	470 μ F, 63 V Electrolytic Capacitors	MCGPR63V477M13X26-RH	Multicomp
Q1	RF Power LDMOS Transistor	AFT26P100-4WSR3	Freescale
R1, R2	0 Ω , 1 A Chip Jumpers	CWCR08050000Z0EA	Vishay
R3, R4	5.1 Ω , 1/8 W Chip Resistors	CRCW08055R10JNEA	Vishay
R5	100 Ω , 1/4 W Chip Resistor	CRCW1206100RFKEA	Vishay
PCB	0.020", $\epsilon_r = 3.5$	RO4350B	Rogers

TYPICAL CHARACTERISTICS (1)

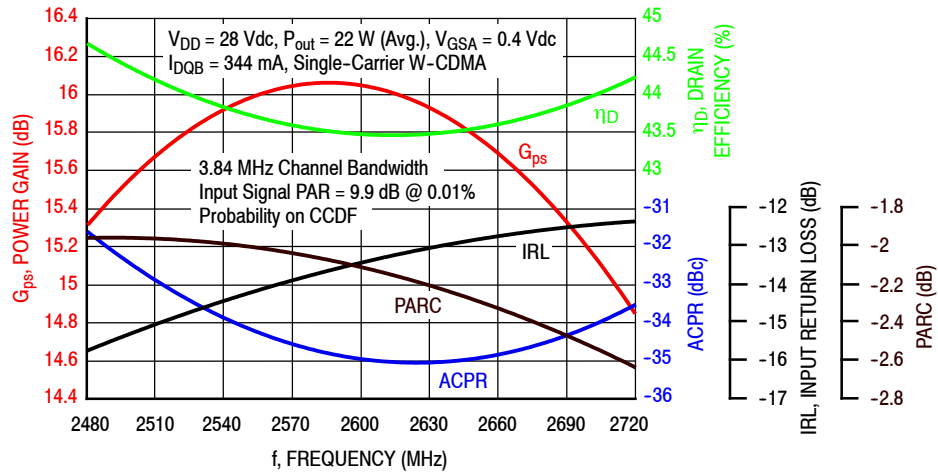

Figure 4. Single-Carrier Output Peak-to-Average Ratio Compression (PARC) Broadband Performance @ $P_{out} = 22$ Watts Avg.

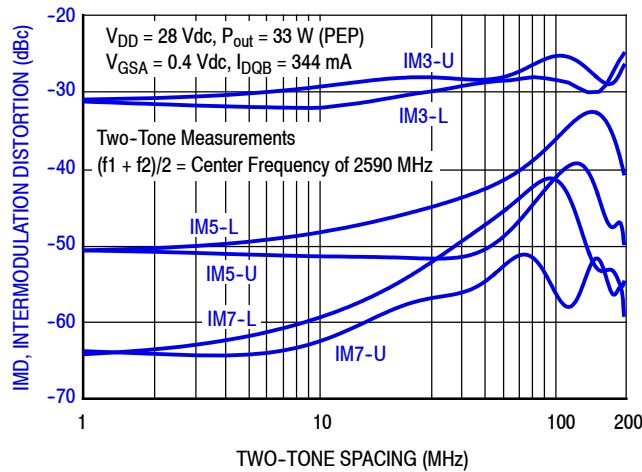

Figure 5. Intermodulation Distortion Products versus Two-Tone Spacing

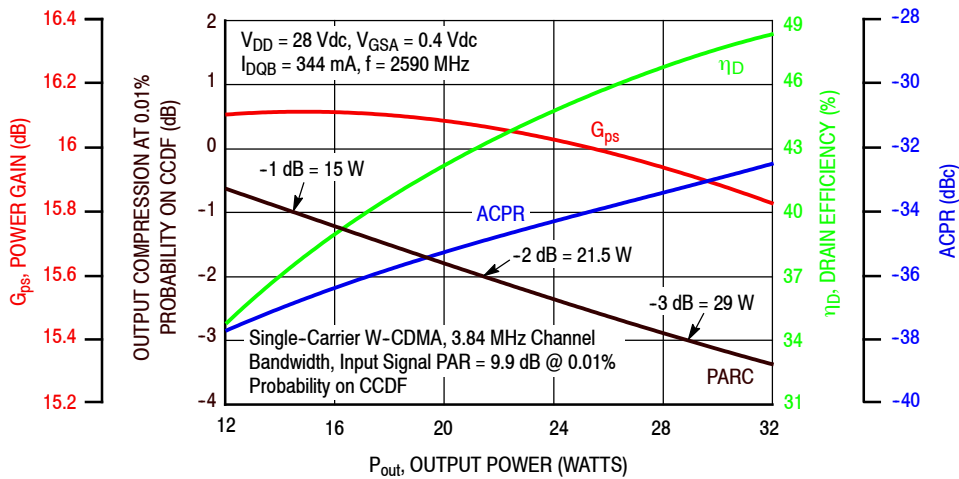

Figure 6. Output Peak-to-Average Ratio Compression (PARC) versus Output Power

1. All characterization data measured in characterization fixture with device soldered to heatsink.

TYPICAL CHARACTERISTICS (1)



Figure 7. Single-Carrier W-CDMA Power Gain, Drain Efficiency and ACPR versus Output Power

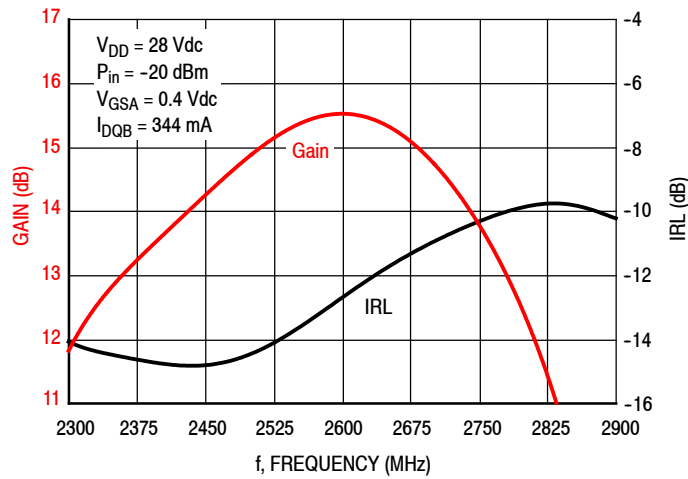

Figure 8. Broadband Frequency Response

1. All characterization data measured in characterization fixture with device soldered to heatsink.

$V_{DD} = 28 \text{ Vdc}$, $I_{DQA} = 189 \text{ mA}$, Pulsed CW, $10 \mu\text{sec(on)}$, 10% Duty Cycle

f (MHz)	$Z_{\text{source}} (\Omega)$	$Z_{\text{in}} (\Omega)$	Max Output Power					
			P1dB					
			$Z_{\text{load}}^{(1)} (\Omega)$	Gain (dB)	(dBm)	(W)	η_D (%)	AM/PM (°)
2500	4.37 - j13.8	5.84 + j14.7	3.19 - j9.50	16.3	48.7	73	53.8	-13
2600	7.22 - j15.5	9.54 + j16.6	3.35 - j9.78	16.7	48.6	73	54.9	-12
2690	13.2 - j15.4	15.2 + j17.0	3.40 - j10.5	16.5	48.8	76	55.8	-11

f (MHz)	$Z_{\text{source}} (\Omega)$	$Z_{\text{in}} (\Omega)$	Max Output Power					
			P3dB					
			$Z_{\text{load}}^{(2)} (\Omega)$	Gain (dB)	(dBm)	(W)	η_D (%)	AM/PM (°)
2500	4.37 - j13.8	5.71 + j15.8	3.19 - j9.84	14.2	49.4	87	54.9	-20
2600	7.22 - j15.5	10.4 + j18.5	3.35 - j10.4	14.4	49.4	87	54.8	-18
2690	13.2 - j15.4	17.9 + j18.8	3.40 - j10.9	14.4	49.5	89	56.1	-16

(1) Load impedance for optimum P1dB power.

(2) Load impedance for optimum P3dB power.

Z_{source} = Measured impedance presented to the input of the device at the package reference plane.

Z_{in} = Impedance as measured from gate contact to ground.

Z_{load} = Measured impedance presented to the output of the device at the package reference plane.

Figure 9. Single Side Load Pull Performance — Maximum Power Tuning

$V_{DD} = 28 \text{ Vdc}$, $I_{DQA} = 189 \text{ mA}$, Pulsed CW, $10 \mu\text{sec(on)}$, 10% Duty Cycle

f (MHz)	$Z_{\text{source}} (\Omega)$	$Z_{\text{in}} (\Omega)$	Max Drain Efficiency					
			P1dB					
			$Z_{\text{load}}^{(1)} (\Omega)$	Gain (dB)	(dBm)	(W)	η_D (%)	AM/PM (°)
2500	4.37 - j13.8	5.16 + j14.8	6.14 - j6.97	18.5	47.1	51	62.9	-20
2600	7.22 - j15.5	8.57 + j17.1	5.28 - j7.45	18.6	47.4	54	62.1	-18
2690	13.2 - j15.4	13.9 + j18.4	4.69 - j7.79	18.4	47.5	57	63.7	-17

f (MHz)	$Z_{\text{source}} (\Omega)$	$Z_{\text{in}} (\Omega)$	Max Drain Efficiency					
			P3dB					
			$Z_{\text{load}}^{(2)} (\Omega)$	Gain (dB)	(dBm)	(W)	η_D (%)	AM/PM (°)
2500	4.37 - j13.8	5.04 + j15.8	5.63 - j7.56	16.2	48.1	65	62.6	-28
2600	7.22 - j15.5	9.18 + j18.8	4.99 - j7.91	16.3	48.3	67	61.9	-25
2690	13.2 - j15.4	16.3 + j20.4	4.60 - j8.25	16.2	48.4	69	63.5	-24

(1) Load impedance for optimum P1dB efficiency.

(2) Load impedance for optimum P3dB efficiency.

Z_{source} = Measured impedance presented to the input of the device at the package reference plane.

Z_{in} = Impedance as measured from gate contact to ground.

Z_{load} = Measured impedance presented to the output of the device at the package reference plane.

Figure 10. Single Side Load Pull Performance — Maximum Drain Efficiency Tuning

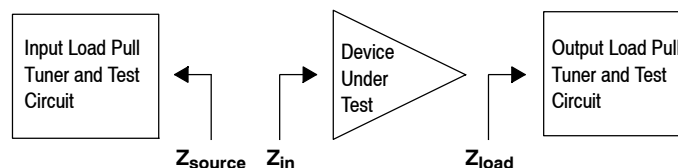

P1dB - TYPICAL LOAD PULL CONTOURS — 2600 MHz

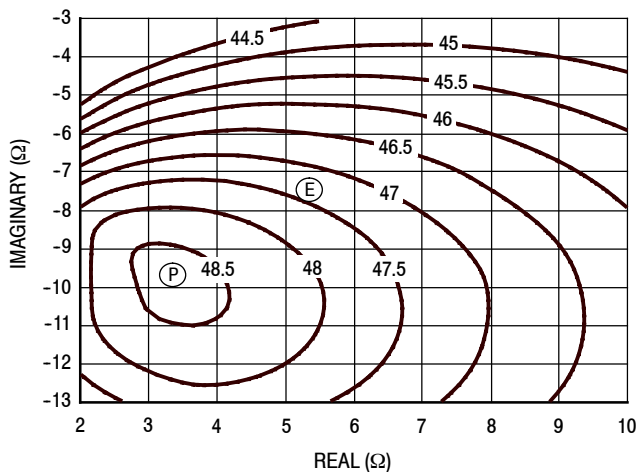

Figure 11. P1dB Load Pull Output Power Contours (dBm)

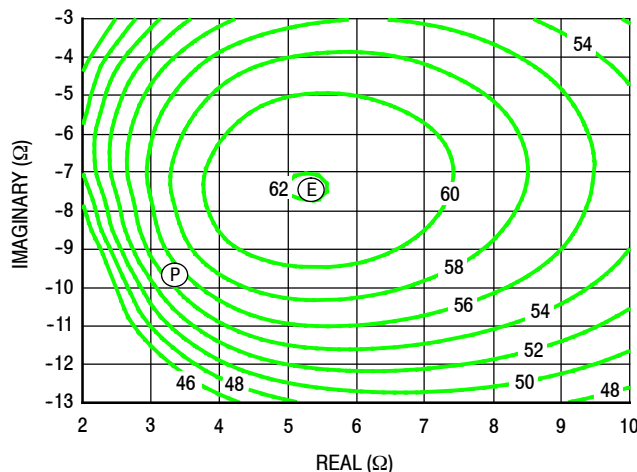

Figure 12. P1dB Load Pull Efficiency Contours (%)

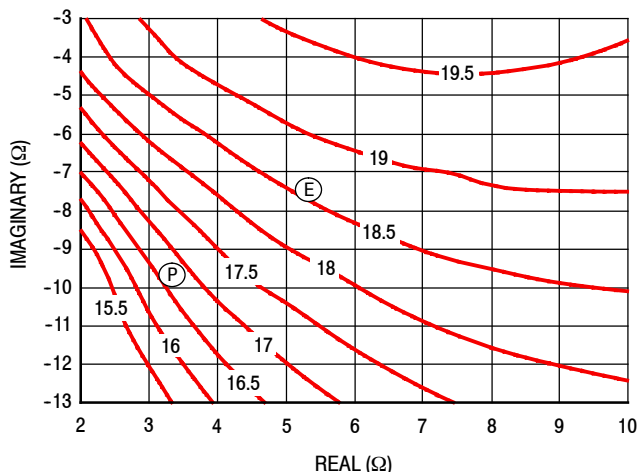

Figure 13. P1dB Load Pull Gain Contours (dB)

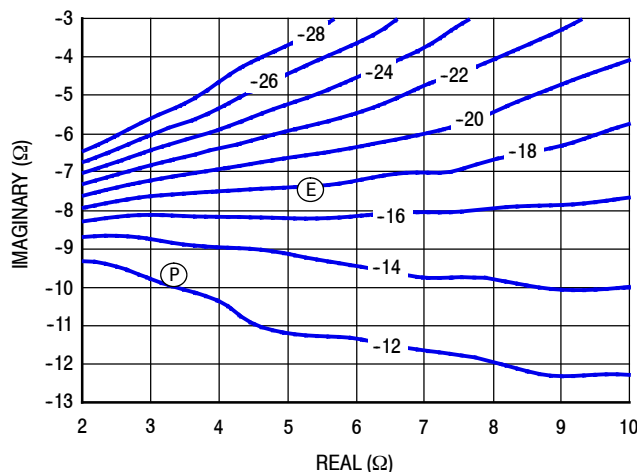

Figure 14. P1dB Load Pull AM/PM Contours (°)

NOTE: (P) = Maximum Output Power
 (E) = Maximum Drain Efficiency

- Gain
- Drain Efficiency
- Linearity
- Output Power

P3dB - TYPICAL LOAD PULL CONTOURS — 2600 MHz

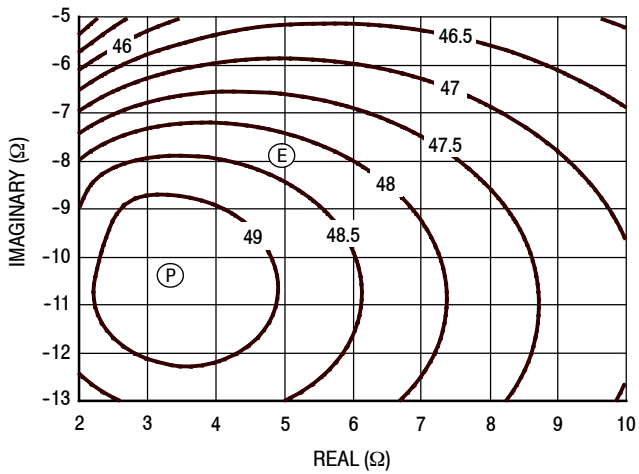

Figure 15. P3dB Load Pull Output Power Contours (dBm)

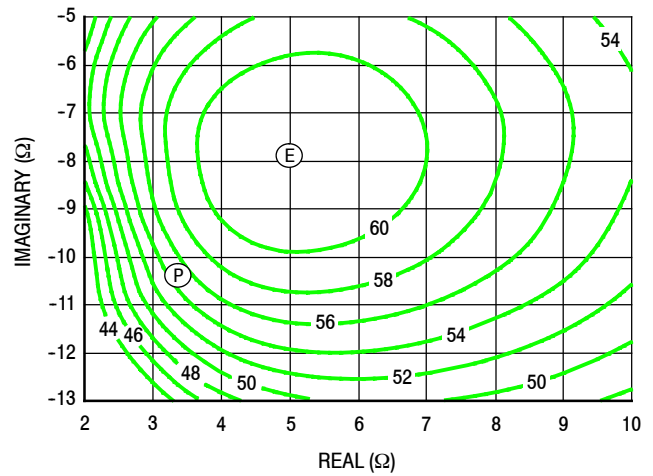

Figure 16. P3dB Load Pull Efficiency Contours (%)

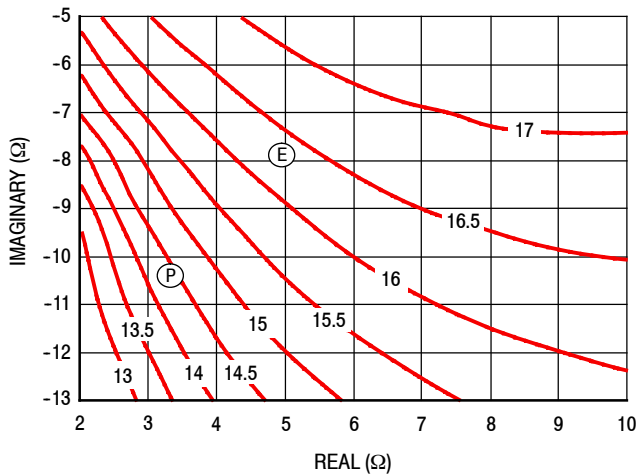

Figure 17. P3dB Load Pull Gain Contours (dB)

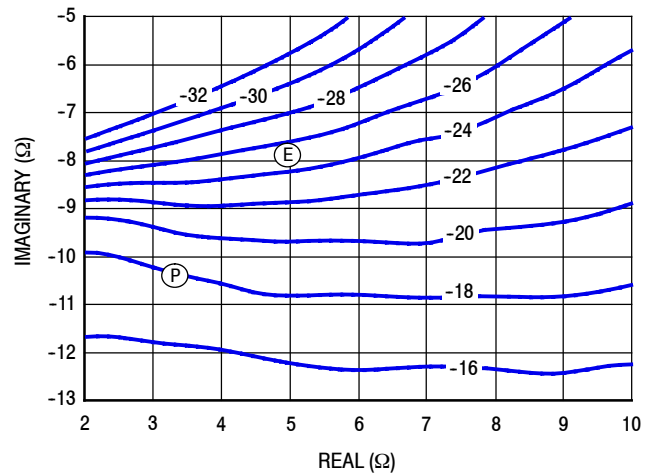
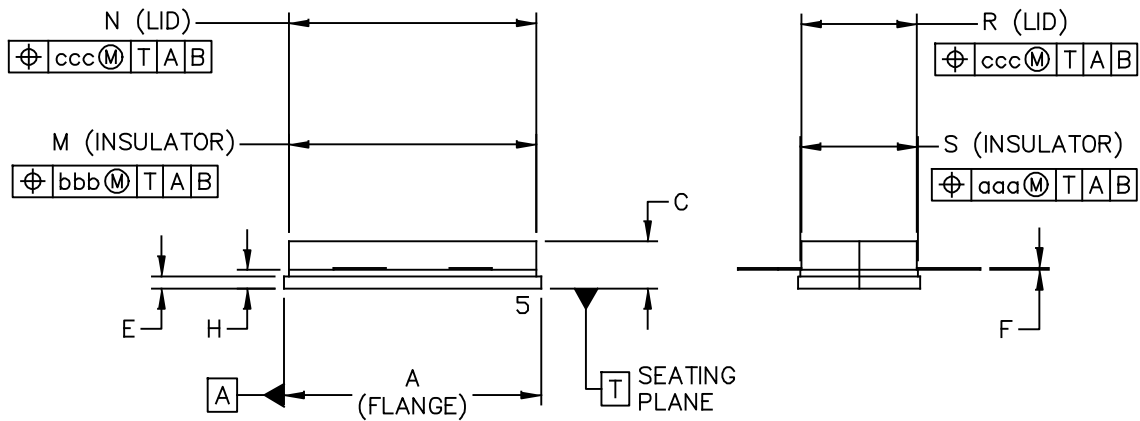
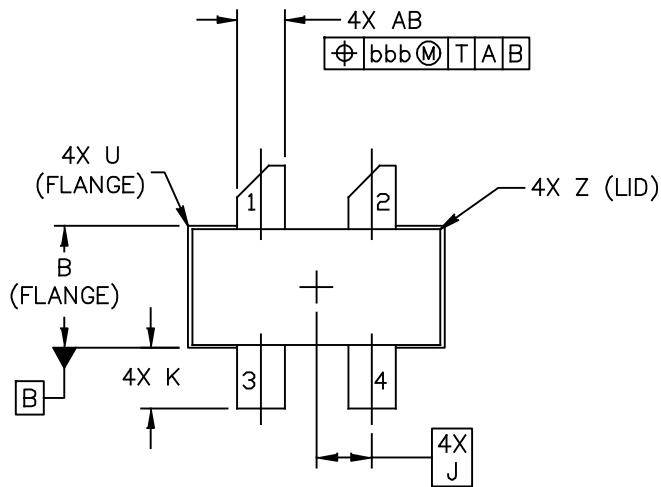

Figure 18. P3dB Load Pull AM/PM Contours (°)

NOTE: (P) = Maximum Output Power
 (E) = Maximum Drain Efficiency

- Gain
- Drain Efficiency
- Linearity
- Output Power

PACKAGE DIMENSIONS



© FREESCALE SEMICONDUCTOR, INC. ALL RIGHTS RESERVED.	MECHANICAL OUTLINE	PRINT VERSION NOT TO SCALE	
TITLE: NI 780S-4	DOCUMENT NO: 98ASA10718D		REV: A
	CASE NUMBER: 465H-02		27 MAR 2007
	STANDARD: NON-JEDEC		

NOTES:

1. DIMENSIONING AND TOLERANCING PER ANSI Y14.5M-1994.
2. CONTROLLING DIMENSION: INCH.
3. DELETED
4. DIMENSION H IS MEASURED .030 (0.762) AWAY FROM PACKAGE BODY.

STYLE 1:

- PIN 1. DRAIN
2. DRAIN
3. GATE
4. GATE
5. SOURCE

DIM	INCH		MILLIMETER		DIM	INCH		MILLIMETER	
	MIN	MAX	MIN	MAX		MIN	MAX	MIN	MAX
A	.805	.815	20.45	20.7	U		.040		1.02
B	.380	.390	9.65	9.91	Z		.030		0.76
C	.125	.170	3.18	4.32	AB	.145	.155	3.68	- 3.94
E	.035	.045	0.89	1.14					
F	.003	.006	0.08	0.15	aaa		.005		0.127
H	.057	.067	1.45	1.7	bbb		.010		0.254
J	.175 BSC		4.44 BSC		ccc		.015		0.381
K	.170	.210	4.32	5.33					
M	.774	.786	19.61	20.02					
N	.772	.788	19.61	20.02					
R	.365	.375	9.27	9.53					
S	.365	.375	9.27	9.52					
© FREESCALE SEMICONDUCTOR, INC. ALL RIGHTS RESERVED.			MECHANICAL OUTLINE			PRINT VERSION NOT TO SCALE			
TITLE: NI 780S-4					DOCUMENT NO: 98ASA10718D			REV: A	
					CASE NUMBER: 465H-02			27 MAR 2007	
					STANDARD: NON-JEDEC				

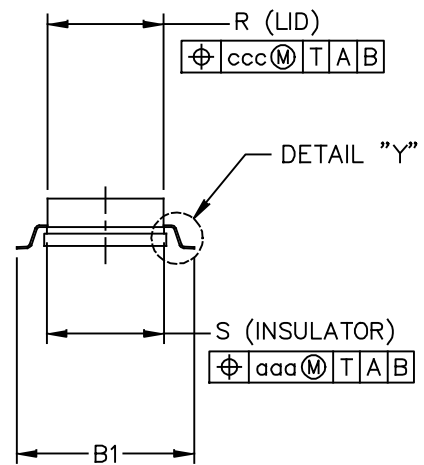
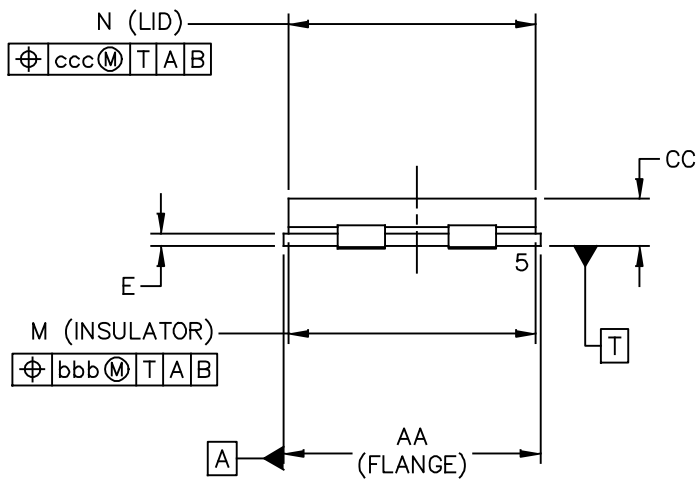
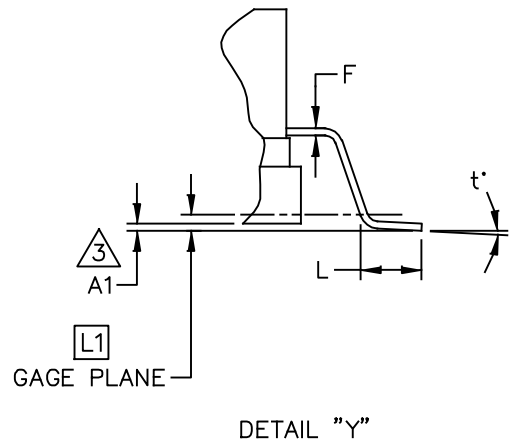
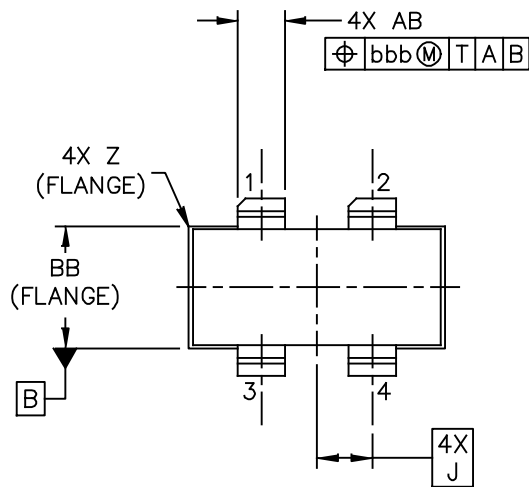

© FREESCALE SEMICONDUCTOR, INC. ALL RIGHTS RESERVED.	MECHANICAL OUTLINE	PRINT VERSION NOT TO SCALE
TITLE: NI-780GS-4L	DOCUMENT NO: 98ASA00238D STANDARD: NON-JEDEC	REV: B 05 SEP 2013

NOTES:

1. DIMENSIONING AND TOLERANCING PER ANSI Y14.5M-1994.

2. CONTROLLING DIMENSION: INCH.

3. DIMENSION A1 IS MEASURED WITH REFERENCE TO DATUM T. THE POSITIVE VALUE IMPLIES THAT THE PACKAGE BOTTOM IS HIGHER THAN THE LEAD BOTTOM.

DIM	INCH		MILLIMETER		DIM	INCH		MILLIMETER	
	MIN	MAX	MIN	MAX		MIN	MAX	MIN	MAX
AA	.805	.815	20.45	20.70	Z	R.000	R.040	R0.00	R1.02
A1	.002	.008	0.05	0.20	AB	.145	.155	3.68	3.94
BB	.380	.390	9.65	9.91	t°	0°	8°	0°	8°
B1	.546	.562	13.87	14.27	aaa	.005		0.13	
CC	.125	.170	3.18	4.32	bbb	.010		0.25	
E	.035	.045	0.89	1.14	ccc	.015		0.38	
F	.003	.006	0.08	0.15					
L	.038	.046	0.97	1.17					
L1	.010 BSC		0.25 BSC						
J	.175 BSC		4.44 BSC						
M	.774	.786	19.66	19.96					
N	.772	.788	19.61	20.02					
R	.365	.375	9.27	9.53					
S	.365	.375	9.27	9.53					
© FREESCALE SEMICONDUCTOR, INC. ALL RIGHTS RESERVED.			MECHANICAL OUTLINE			PRINT VERSION NOT TO SCALE			
TITLE: NI-780GS-4L					DOCUMENT NO: 98ASA00238D REV: B				
					STANDARD: NON-JEDEC				
					05 SEP 2013				

PRODUCT DOCUMENTATION, SOFTWARE AND TOOLS

Refer to the following resources to aid your design process.

Application Notes

- AN1955: Thermal Measurement Methodology of RF Power Amplifiers

Engineering Bulletins

- EB212: Using Data Sheet Impedances for RF LDMOS Devices

Software

- Electromigration MTTF Calculator
- RF High Power Model
- .s2p File

Development Tools

- Printed Circuit Boards

For Software and Tools, do a Part Number search at <http://www.freescale.com>, and select the “Part Number” link. Go to Software & Tools on the part’s Product Summary page to download the respective tool.

REVISION HISTORY

The following table summarizes revisions to this document.

Revision	Date	Description
0	May 2013	<ul style="list-style-type: none">• Initial Release of Data Sheet
1	Aug. 2013	<ul style="list-style-type: none">• Fig. 3, AFT26P100-4WSR3 Characterization Test Circuit Component Layout, updated to include soldered down device in the layout drawing, p. 5• Table 6, AFT26P100-4WSR3 Characterization Test Circuit Component Designations and Values, updated to include soldered down Freescale device, p. 5
2	Mar. 2015	<ul style="list-style-type: none">• Added part number AFT26P100-4WGSR3, p. 1• Added NI-780GS-4L package isometric, p. 1, and Mechanical Outline, pp. 13-14

How to Reach Us:

Home Page:
freescale.com

Web Support:
freescale.com/support

Information in this document is provided solely to enable system and software implementers to use Freescale products. There are no express or implied copyright licenses granted hereunder to design or fabricate any integrated circuits based on the information in this document.

Freescale reserves the right to make changes without further notice to any products herein. Freescale makes no warranty, representation, or guarantee regarding the suitability of its products for any particular purpose, nor does Freescale assume any liability arising out of the application or use of any product or circuit, and specifically disclaims any and all liability, including without limitation consequential or incidental damages. "Typical" parameters that may be provided in Freescale data sheets and/or specifications can and do vary in different applications, and actual performance may vary over time. All operating parameters, including "typicals," must be validated for each customer application by customer's technical experts. Freescale does not convey any license under its patent rights nor the rights of others. Freescale sells products pursuant to standard terms and conditions of sale, which can be found at the following address: freescale.com/SalesTermsandConditions.

Freescale and the Freescale logo are trademarks of Freescale Semiconductor, Inc., Reg. U.S. Pat. & Tm. Off. Airfast is a trademark of Freescale Semiconductor, Inc. All other product or service names are the property of their respective owners.

© 2013, 2015 Freescale Semiconductor, Inc.



AMEYA360

Components Supply Platform

Authorized Distribution Brand :



Website :

Welcome to visit www.ameya360.com

Contact Us :

➤ Address :

401 Building No.5, JiuGe Business Center, Lane 2301, Yishan Rd
Minhang District, Shanghai , China

➤ Sales :

Direct +86 (21) 6401-6692

Email amall@ameya360.com

QQ 800077892

Skype [ameyasales1](#) [ameyasales2](#)

➤ Customer Service :

Email service@ameya360.com

➤ Partnership :

Tel +86 (21) 64016692-8333

Email mkt@ameya360.com