

# Arria 10 Device Overview

2013.09.04

AIB-01023

 [Subscribe](#)  [Feedback](#)

Altera's Arria® FPGAs and SoCs deliver optimal performance and power efficiency in the midrange. By using TSMC's 20-nm process technology on a high-performance architecture, Arria 10 FPGAs and SoCs deliver higher performance than previous-generation high-end FPGAs while simultaneously reducing power by offering a comprehensive set of power-saving technologies. Altera's Arria 10 family is reinventing the midrange.

Altera's Arria 10 SoCs offer a second generation SoC product that both demonstrates a long-term commitment to the SoC product line and extends Altera's leadership in programmable devices that feature the ARM-based hard processor system (HPS).

Important innovations in Arria 10 devices include:

- Enhanced core architecture delivering 60% higher performance than the previous generation midrange (15% higher performance than previous fastest high-end FPGAs)
- Integrated transceivers with short reach rates up to 28.05 Gbps and backplane capability up to 17.4 Gbps
- Hard PCI Express Gen3 intellectual property (IP) blocks
- Hard memory controllers and PHY up to 2666 Mbps
- Variable precision digital signal processing (DSP) blocks
- Fractional synthesis PLLs
- Up to 40% lower power compared to prior midrange FPGAs and up to 60% lower power compared to prior generation high-end FPGAs due to a comprehensive set of advanced power-saving features
- 2nd generation ARM® Cortex™ -A9 hard processor system (HPS) for SoC variants
- Integrated 10GBASE-KR/40GBASE-KR4 Forward Error Correction (FEC)

Arria 10 devices are ideally suited for high performance, power-sensitive, midrange applications in such diverse markets as:

- **Wireless**—for channel and switch cards in remote radio heads and mobile backhaul
- **Broadcast**—for studio switches, servers and transport, videoconferencing, and pro audio/video
- **Wireline**—for 40G/100G muxponders and transponders, 100G line cards, bridging, and aggregation
- **Compute and Storage**—for flash cache, cloud computing servers, and server acceleration
- **Medical**—for diagnostic scanners and diagnostic imaging
- **Military**—for missile guidance and control, radar, electronic warfare, and secure communications

© 2013 Altera Corporation. All rights reserved. ALTERA, ARRIA, CYCLONE, HARDCOPY, MAX, MEGACORE, NIOS, QUARTUS and STRATIX words and logos are trademarks of Altera Corporation and registered in the U.S. Patent and Trademark Office and in other countries. All other words and logos identified as trademarks or service marks are the property of their respective holders as described at [www.altera.com/common/legal.html](http://www.altera.com/common/legal.html). Altera warrants performance of its semiconductor products to current specifications in accordance with Altera's standard warranty, but reserves the right to make changes to any products and services at any time without notice. Altera assumes no responsibility or liability arising out of the application or use of any information, product, or service described herein except as expressly agreed to in writing by Altera. Altera customers are advised to obtain the latest version of device specifications before relying on any published information and before placing orders for products or services.

ISO  
9001:2008  
Registered



## Arria 10 Family Variants

Arria 10 devices are available in GX, GT, and SX variants.

- **Arria 10 GX** devices deliver over 500 MHz core fabric performance and 2666 Mbps DDR4 external memory interface performance across the industrial temperature range, while providing over 1.1 million logic elements and 96 general purpose transceivers. Every transceiver is capable of 17.4 Gbps for short reach applications and 16.0 Gbps across the backplane. These devices are optimized for a broad range of applications such as wireless remote radio heads, broadcast studio equipment, 40G/100G communication systems, server acceleration, and medical imaging.
- **Arria 10 GT** devices have the same core performance and feature set as Arria 10 GX devices, with the added capability of sixteen 28.05-Gbps short reach transceivers for chip-to-chip and chip-to-module applications. The 28.05-Gbps transceivers are ideal for interfacing with the emerging CFP2 and CFP4 optical modules that typically require four lanes at data rates in the range of 25 to 28 Gbps. Backplane driving capability is also increased to 17.4 Gbps in Arria 10 GT devices.
- **Arria 10 SX** devices have a feature set that is similar to Arria 10 GX devices plus an ARM Cortex-A9 hard processor system.

Common to all Arria 10 family variants is the enhanced logic array utilizing Altera's adaptive logic module (ALM) and a rich set of high performance building blocks that includes 20Kbit (M20K) internal memory blocks, variable precision DSP blocks, fractional synthesis and integer PLLs, hard memory PHY and controllers for external memory interfaces, and general purpose I/O cells. These building blocks are interconnected by an updated version of Altera's superior multi-track routing architecture and comprehensive fabric clocking network. All devices support in-system, fine-grained partial reconfiguration of the logic array, allowing logic to be added and removed from the system during operation.

All family variants also contain high speed serial transceivers, containing both the physical medium attachment (PMA) and the physical coding sublayer (PCS), which can be used to implement a variety of industry standard and proprietary protocols. In addition to the hard PCS, Arria 10 devices contain multiple instantiations of PCI Express hard IP that supports Gen1/Gen2/Gen3 rates in x1/x2/x4/x8 lane configurations. The hard PCS and hard PCI Express IP free up valuable core logic resources, save power, and increase productivity for the user.

## Improvements in Arria 10 FPGAs and SoCs

Altera has combined in-house innovations with TSMC's advanced 20-nm process technology to deliver major improvements over Arria V FPGAs and SoCs in nearly every category.

**Table 1: Key Features of Arria 10 Devices Compared to Arria V Devices**

Feature	Arria V FPGAs and SoCs	Arria 10 FPGAs and SoCs
<b>Process technology</b>	28-nm TSMC	20-nm TSMC
<b>Processor core</b>	Dual ARM Cortex-A9 MPCore™	Dual ARM Cortex-A9 MPCore
<b>Processor performance</b>	800 MHz	1.5 GHz
<b>Logic core performance</b>	300 MHz	500 MHz
<b>Power dissipation</b>	1x	0.6x

Feature	Arria V FPGAs and SoCs	Arria 10 FPGAs and SoCs
<b>Logic density</b>	504 KLE	1150 KLE
<b>Embedded memory</b>	34 Mbits	53 Mbits
<b>18x19 multipliers</b>	2186	3356
<b>Maximum transceivers</b>	36	96
<b>Maximum transceiver data rate (chip to chip)</b>	10.3125 Gbps	28.05 Gbps
<b>Memory devices supported</b>	DDR3 SDRAM @ 667 MHz/1333 Mbps	DDR4 SDRAM @ 1333 MHz/2666 Mbps DDR3 SDRAM @ 1067 MHz/2133 Mbps Hybrid Memory Cube (HMC)
<b>Hard protocol IP</b>	2 EMACs PCI Express Gen3 x8 (Arria V GZ) PCI Express Gen2 x4/Gen1 x8 (Arria V GX/GT/SX/ST)	3 EMACs PCI Express Gen3 x8 10GBASE-KR/40GBASE-KR4 FEC Interlaken PCS

These features result in the following improvements:

- **Improved Core Logic Performance:** Arria 10 devices offer over 60% improved core performance compared to the previous generation
- **Improved Processor Performance:** Arria 10 SoCs provide 87% improvement in processor performance
- **Improved Processor Power Efficiency:** At 20 nm, the Dual Core ARM Cortex-A9 Processor provides the best power efficiency for any GHz-class processor in the industry
- **Lower Power:** Arria 10 devices deliver up to 40% lower power compared to prior-generation mid-range FPGAs and SoCs, enabled by 20-nm process technology advancements and a variety of innovative power-management options
- **Higher Density:** Arria 10 devices provide a higher level of integration with up to 1150K logic elements (LEs), up to 53 Mbits of embedded memory, and over 3350 18x19 multipliers
- **Improved Transceiver Bandwidth:** Arria 10 devices support chip-to-chip rates up to 28 Gbps and backplane rates up to 17.4 Gbps
- **Improved Memory Bandwidth with DDR4 Support:** Arria 10 devices support DDR4 memory up to 1333 MHz/ 2666 Mbps and feature support for the emerging transceiver-based Hybrid Memory Cube (HMC)
- **Improved DSP Performance:** With over 1.0 TeraFLOPs of single-precision DSP performance, Arria 10 devices deliver a 4 times increase in DSP performance
- **Additional Protocol Support for Hard IP:** Arria 10 devices feature an advanced transceiver architecture with added hard IP support for PCIe Gen3, Interlaken PCS, and 10GBASE-KR/40GBASE-KR4 FEC





## Target Markets for Arria 10 FPGAs and SoCs

Arria 10 devices meet the performance, power, and bandwidth requirements of next generation wireless infrastructure, broadcast, compute and storage, networking, and medical and military equipment.

By providing such a highly integrated device, Arria 10 FPGAs and SoCs significantly reduce BOM cost, form factor, and power consumption. Arria 10 devices allow you to differentiate your product through customization by implementing your intellectual property in both hardware and software.

For these applications, Arria 10 devices integrate both logic functions and processor functions in a highly integrated single device. The integrated ARM-based SoCs provide all the functionality of traditional FPGAs, eliminate the need for a local processor, and increase system performance by taking advantage of the tightly coupled high bandwidth interface between the core fabric and the hard processor system.

**Figure 1: Arria 10 FPGA and SoC Applications**

Wireless Infrastructure	Access, Metro & Core	Transmission	Cloud Servers and Storage	Broadcast
				
<b>Target Applications</b>				
<ul style="list-style-type: none"> <li>• Remote Radio Head</li> <li>• Mobile Backhaul</li> <li>• Active Antenna</li> <li>• Basestation (BTS)</li> <li>• 4G/LTE Macro eNB</li> <li>• 4G/LTE Micro eNB</li> </ul>	<ul style="list-style-type: none"> <li>• 40G GPON, EPON, FTTN, Switch</li> <li>• 100G / 200G NGPON</li> <li>• 100G Traffic Management</li> </ul>	<ul style="list-style-type: none"> <li>• NX 100G OTU 4</li> <li>• 2 X OTU 4</li> <li>• 4 X OTU 4</li> </ul>	<ul style="list-style-type: none"> <li>• Flash Cache</li> <li>• Cloud</li> <li>• Server</li> <li>• Acceleration</li> </ul>	<ul style="list-style-type: none"> <li>• Pro A/V Equipment</li> <li>• Switcher</li> <li>• Server</li> <li>• Transport</li> <li>• Head End</li> <li>• VoD Mux</li> </ul>
<b>Logic Functions</b>				
<ul style="list-style-type: none"> <li>• RF Processing</li> <li>• Digital Pre-Distortion (DPD)</li> <li>• Baseband Interface</li> </ul>	<ul style="list-style-type: none"> <li>• Aggregation</li> <li>• Bridging</li> <li>• Switching</li> <li>• Traffic Management</li> <li>• I/O</li> </ul>	<ul style="list-style-type: none"> <li>• FEC</li> <li>• Aggregation</li> <li>• Muxponding</li> <li>• I/O</li> </ul>	<ul style="list-style-type: none"> <li>• Flash Cache Processing</li> <li>• Acceleration</li> <li>• SATA/SAS</li> <li>• PCIe Gen3</li> </ul>	<ul style="list-style-type: none"> <li>• Video Format Conversion</li> <li>• Muxing</li> <li>• Switching</li> <li>• Bridging</li> </ul>
<b>Processor Functions</b>				
<ul style="list-style-type: none"> <li>• OAM &amp; Link</li> <li>• Digital Pre-Distortion (DPD)</li> <li>• L2 Switch</li> <li>• I/O, Protocol Control</li> </ul>	<ul style="list-style-type: none"> <li>• Host Offload</li> <li>• OAM &amp; Link</li> <li>• L2 Switch</li> <li>• I/O, Protocol Control</li> <li>• Chassis Management</li> </ul>	<ul style="list-style-type: none"> <li>• Host Offload</li> <li>• OAM &amp; Link</li> <li>• I/O Control</li> <li>• Chassis Management</li> </ul>	<ul style="list-style-type: none"> <li>• Flash Cache Control</li> <li>• Host Offload</li> <li>• Co-processing &amp; Acceleration Control</li> </ul>	<ul style="list-style-type: none"> <li>• Audio Processing</li> <li>• Video Compression</li> <li>• Link Management</li> </ul>

- For **Wireless infrastructure** particularly remote radio unit, the industry has standardized on ARM-based ASSPs and SoCs for several generations. ARM is widely recognized as the industry leader in low power solutions. At 20 nm, the Dual ARM Cortex MPCore provides the best power efficiency of any GHz class of process. When combined with Altera’s industry leading programmable technology, this provides an ideal platform to address the performance, power, and form factor requirements of wireless remote radio unit and small cell base stations.
- For **Wireline communication equipment** such as access, metro, core, and transmission equipment where the FPGA performs critical functions such as protocol bridging, packet framing, aggregation, and I/O expansion, SoCs now offer all this as well as integrated intelligent control and link management, sometimes referred to as Operations, Administration, and Maintenance (OAM). OAM typically is software that executes when a link is established or fails during operation. The integrated ARM processor can also be used for statistics and error monitoring and minimize system downtime when a link is compromised or oversubscribed. Tight coupling of the processor and the data path (implemented in the core logic) saves time and results in significant savings in terms of operating expenses associated with system downtime and loss of quality of service.
- For **Compute and storage equipment**, flash cache storage, the integrated ARM processor can be used to manage Flash sectors and improve overall life and reliability as well as offload the host processor and provide control for search and hardware acceleration functions for cloud storage equipment. The integrated ARM based HPS can configure the hard PCIe interfaces in PCIe root port configuration and also run link layers for SAS and SATA interfaces.
- For **Next generation Broadcast equipment**, where “4K readiness” is the key technology driver, the integrated ARM processor subsystem eliminates the need for a local GHz class processor, which is commonly used for functions such as audio processing, video compression, video link management, and PCIe root port.
- For **Military** applications, new security features such as Secure Boot, Encryption, and Authentication have been introduced for secure wireless and wireline communications, military radar, military intelligence equipment.
- For **Test and Medical** applications, combining ARM HPS with support for high speed memory devices such as DDR4, and Hybrid Memory Cube (HMC) as well as high speed transceivers and embedded controllers such as PCIe Gen3, Arria 10 SoCs are ideal for next generation test and medical equipment.

## FPGA and SoC Features Summary

Table 2: Arria 10 FPGA and SoC Common Device Features

Feature	Description
Technology	<ul style="list-style-type: none"> <li>• 20-nm TSMC SoC process technology</li> <li>• 0.9 V standard V<sub>CC</sub> core voltage</li> </ul>

Feature	Description
Low power serial transceivers	<ul style="list-style-type: none"> <li>• Continuous operating range of 611 Mbps to 17.4 Gbps for Arria 10 GX devices</li> <li>• Continuous operating range of 611 Mbps to 28.05 Gbps for Arria 10 GT devices</li> <li>• Backplane support up to 16.0 Gbps for Arria 10 GX devices</li> <li>• Backplane support up to 17.4 Gbps for Arria 10 GT devices</li> <li>• Extended range down to 125 Mbps with oversampling</li> <li>• ATX transmit PLLs with user-configurable fractional synthesis capability</li> <li>• Electronic Dispersion Compensation (EDC) for XFP, SFP+, QSFP, and CFP optical module support</li> <li>• Adaptive linear and decision feedback equalization</li> <li>• Transmit pre-emphasis and de-emphasis</li> <li>• Dynamic partial reconfiguration of individual transceiver channels</li> <li>• On-chip instrumentation (EyeQ non-intrusive data eye monitoring)</li> </ul>
General purpose I/Os	<ul style="list-style-type: none"> <li>• 1.6 Gbps LVDS—every pair can be configured as an input or output</li> <li>• 1333 MHz/2666 Mbps DDR4 external memory interface</li> <li>• 1067 MHz/2133 Mbps DDR3 external memory interface</li> <li>• 1.2 V to 3.0 V single-ended LVCMOS/LVTTL interfacing</li> <li>• On-chip termination (OCT)</li> </ul>
Embedded hard IP	<ul style="list-style-type: none"> <li>• PCIe Gen1/Gen2/Gen3 complete protocol stack, x1/x2/x4/x8 end point and root port</li> <li>• DDR4/DDR3/DDR3L/DDR3U/RLDRAM 3/LPDDR3 hard memory controller (RLDRAM2/QDR II+ using soft memory controller)</li> <li>• Multiple hard IP instantiations in each device</li> <li>• Dual-core ARM Cortex-A9 processor (Arria 10 SX devices only)</li> </ul>
Transceiver hard IP	<ul style="list-style-type: none"> <li>• 10GBASE-KR/40GBASE-KR4 Forward Error Correction (FEC)</li> <li>• 10G Ethernet PCS</li> <li>• PCI Express PIPE interface</li> <li>• Interlaken PCS</li> <li>• Gigabit Ethernet PCS</li> <li>• Deterministic latency support for Common Public Radio Interface (CPRI) PCS</li> <li>• Fast lock-time support for Gigabit Passive Optical Networking (GPON) PCS</li> <li>• 8B/10B, 64B/66B, 64B/67B encoders and decoders</li> <li>• Custom mode support for proprietary protocols</li> </ul>
Power management	<ul style="list-style-type: none"> <li>• SmartVoltage ID</li> <li>• V<sub>CC</sub> PowerManager</li> <li>• Low static power device options</li> <li>• Programmable Power Technology</li> <li>• Quartus® II integrated PowerPlay power analysis</li> </ul>
High performance core fabric	<ul style="list-style-type: none"> <li>• Enhanced adaptive logic module (ALM) with 4 registers</li> <li>• Improved multi-track routing architecture reduces congestion and improves compile times</li> <li>• Hierarchical core clocking architecture</li> <li>• Fine-grained partial reconfiguration</li> </ul>

Feature	Description
Internal memory blocks	<ul style="list-style-type: none"> <li>• M20K—20-Kbit with hard ECC support</li> <li>• MLAB—640-bit distributed LUTRAM</li> </ul>
Variable precision DSP blocks	<ul style="list-style-type: none"> <li>• Natively supports signal processing with precision ranging from 18x19 up to 54x54</li> <li>• Native 27x27 multiply mode</li> <li>• 64-bit accumulator and cascade for systolic FIRs</li> <li>• Internal coefficient memory banks</li> <li>• Pre-adder/subtractor improves efficiency</li> <li>• Additional pipeline register increases performance and reduces power</li> </ul>
Phase locked loops (PLL)	<ul style="list-style-type: none"> <li>• Fractional synthesis PLLs (fPLL) support both fractional and integer modes</li> <li>• Fractional mode with third-order delta-sigma modulation</li> <li>• Precision frequency synthesis, clock delay compensation, zero delay buffering</li> <li>• Integer PLLs adjacent to general purpose I/Os, support external memory, and LVDS interfaces</li> </ul>
Core clock networks	<ul style="list-style-type: none"> <li>• 800 MHz fabric clocking</li> <li>• 667 MHz external memory interface clocking, supports 2666 Mbps DDR4 interface</li> <li>• 800 MHz LVDS interface clocking, supports 1600 Mbps LVDS interface</li> <li>• Global, regional, and peripheral clock networks</li> <li>• Unused clock trees powered down to reduce dynamic power</li> </ul>
Configuration	<ul style="list-style-type: none"> <li>• Serial and parallel flash interface</li> <li>• Configuration via protocol (CvP) using PCI Express Gen1/Gen2/Gen3</li> <li>• Fine-grained partial reconfiguration of core fabric</li> <li>• Dynamic reconfiguration of transceivers and PLLs</li> <li>• 256-bit AES bitstream encryption design security with authentication</li> <li>• Tamper protection</li> </ul>
Packaging	<ul style="list-style-type: none"> <li>• Multiple devices with identical package footprints allows seamless migration across different FPGA densities</li> <li>• Devices with compatible package footprints allows migration to next generation high-end Stratix<sup>®</sup> 10 devices</li> <li>• 1.0 mm ball-pitch FBGA packaging</li> <li>• Lead and lead-free package options</li> </ul>
Software and tools	<ul style="list-style-type: none"> <li>• Quartus II design suite</li> <li>• Transceiver toolkit</li> <li>• Qsys system integration tool</li> <li>• DSP Builder advanced blockset</li> <li>• OpenCL<sup>™</sup> support</li> <li>• SoC Embedded Design Suite (EDS)</li> </ul>

Table 3: Arria 10 SoC-Specific Device Features

Feature	Description
Dual-core ARM Cortex-A9 MPCore processor unit	<ul style="list-style-type: none"> <li>• 2.5 MIPS/MHz instruction efficiency</li> <li>• CPU frequency 1.2 GHz with 1.5 GHz via overdrive               <ul style="list-style-type: none"> <li>• At 1.5 GHz total performance of 7500 MIPS</li> </ul> </li> <li>• ARMv7-A architecture               <ul style="list-style-type: none"> <li>• Runs 32-bit ARM instructions</li> <li>• 16-bit and 32-bit Thumb instructions for 30% reduction in memory footprint</li> <li>• Jazelle<sup>®</sup> RCT execution architecture with 8-bit Java bytecodes</li> <li>• Superscalar, variable length, out-of-order pipeline with dynamic branch prediction</li> </ul> </li> <li>• ARM NEON<sup>™</sup> media processing engine</li> <li>• Single- and double-precision floating-point unit</li> <li>• CoreSight<sup>™</sup> debug and trace technology</li> <li>• Snoop Control Unit (SCU) and Acceleration Coherency Port (ACP)</li> </ul>
Cache	<ul style="list-style-type: none"> <li>• L1 Cache               <ul style="list-style-type: none"> <li>• 32 KB of instruction cache</li> <li>• 32 KB of L1 data cache</li> <li>• Parity checking</li> </ul> </li> <li>• L2 Cache               <ul style="list-style-type: none"> <li>• 512 KB shared</li> <li>• 8-way set associative</li> <li>• SEU Protection with parity on TAG ram and ECC on data RAM</li> <li>• Cache lockdown support</li> </ul> </li> </ul>
On-Chip Memory	<ul style="list-style-type: none"> <li>• 256 KB of scratch on-chip RAM</li> <li>• 64 KB on-chip ROM</li> </ul>



Feature	Description
External Memory Interface for HPS	<ul style="list-style-type: none"><li>• Hard memory controller with support for DDR4, DDR3, DDR2, LPDDR2<ul style="list-style-type: none"><li>• 40-bit (32-bit + 8-bit ECC) with select packages supporting 72-bit (64-bit + 8-bit ECC)</li><li>• Support for up to 2666 Mbps DDR4 and 2166 Mbps DDR3 frequencies</li><li>• Error correction code (ECC) support including calculation, error correction, write-back correction, and error counters</li><li>• Software Configurable Priority Scheduling on individual SDRAM bursts ECC</li><li>• Fully programmable timing parameter support for all JEDEC specified timing parameters</li><li>• AXI<sup>®</sup> Quality of Service (QoS) support for interface to logic core</li><li>• Multiport front-end (MPFE) scheduler interface to hard memory controller</li></ul></li><li>• Queued serial peripheral interface (QSPI) flash controller allows port sharing of hard memory controller between CPU and logic core<ul style="list-style-type: none"><li>• Single I/O (SIO), Dual I/O (DIO), and Quad I/O (QIO) SPI Flash support</li><li>• Support for up to 108 MHz for flash frequency</li></ul></li><li>• NAND flash controller<ul style="list-style-type: none"><li>• ONFI 1.0 or later</li><li>• Integrated descriptor based with DMA</li><li>• New command DMA to offload CPU for fast power down recovery</li><li>• Programmable hardware ECC support</li><li>• Updated to support 8 and 16 bit Flash devices</li><li>• Support for 50 MHz flash frequency</li></ul></li><li>• Secure Digital SD/SDIO/MMC controller<ul style="list-style-type: none"><li>• eMMC 4.5</li><li>• Integrated descriptor based DMA</li><li>• CE-ATA digital commands supported</li><li>• 50 MHz operating frequency</li></ul></li><li>• Direct memory access (DMA) controller<ul style="list-style-type: none"><li>• 8-channel</li><li>• Supports up to 32 peripheral handshake interface</li></ul></li></ul>

Feature	Description
Communication Interface Controllers	<ul style="list-style-type: none"> <li>• Three 10/100/1000 Ethernet media access controls (MAC) with integrated DMA               <ul style="list-style-type: none"> <li>• Supports RGMII and RMII external PHY Interfaces</li> <li>• Option to support other PHY interfaces through FPGA logic                   <ul style="list-style-type: none"> <li>• GMII and SGMII</li> </ul> </li> <li>• Supports IEEE 1588-2002 and IEEE 1588-2008 standards for precision networked clock synchronization</li> <li>• Supports IEEE 802.1Q VLAN tag detection for reception frames</li> <li>• Supports Ethernet AVB standard</li> </ul> </li> <li>• 2 USB On-the-Go (OTG) controllers with DMA               <ul style="list-style-type: none"> <li>• Dual-Role Device (device and host functions)                   <ul style="list-style-type: none"> <li>• High-speed (480 Mbps)</li> <li>• Full-speed (12 Mbps)</li> <li>• Low-speed (1.5 Mbps)</li> <li>• Supports USB 1.1 (full-speed and low-speed)</li> </ul> </li> <li>• Integrated descriptor-based scatter-gather DMA</li> <li>• Support for external ULPI PHY</li> <li>• Up to 16 bidirectional endpoints, including control endpoint</li> <li>• Up to 16 host channels</li> <li>• Supports generic root hub</li> <li>• Configurable to OTG 1.3 and OTG 2.0 modes</li> </ul> </li> <li>• 5 I<sup>2</sup>C controllers (3 can be used by EMAC for MIO to external PHY)               <ul style="list-style-type: none"> <li>• Support both 100Kbps and 400Kbps modes</li> <li>• Support both 7-bit and 10-bit addressing modes</li> <li>• Support Master and Slave operating mode</li> </ul> </li> <li>• 2 UART 16550 compatible               <ul style="list-style-type: none"> <li>• Support IrDA 1.0 SIR mode</li> <li>• Programmable baud rate up to 115.2Kbaud</li> </ul> </li> <li>• 4 serial peripheral interfaces (SPI) (2 Master, 2 Slaves)               <ul style="list-style-type: none"> <li>• Full and Half duplex</li> </ul> </li> </ul>
Timers and I/O	<ul style="list-style-type: none"> <li>• Timers               <ul style="list-style-type: none"> <li>• 7 general-purpose timers</li> <li>• 4 watchdog timers</li> </ul> </li> <li>• 62 programmable general-purpose I/O (GPIO)               <ul style="list-style-type: none"> <li>• 3 modules 24, 24, and 14</li> </ul> </li> <li>• 48 I/O direct share I/O allows HPS peripherals to connect directly to I/O</li> </ul>
Security	<ul style="list-style-type: none"> <li>• Anti-tamper, secure boot, Advanced Encryption Standard (AES) and authentication (SHA)</li> </ul>

Feature	Description
Interconnect to Logic Core	<ul style="list-style-type: none"><li>• High-performance ARM AMBA<sup>®</sup> AXI bus bridges<ul style="list-style-type: none"><li>• AMBA AXI-3 compliant</li><li>• Allows both independent and tightly coupled operation between HPS and logic core</li><li>• Support simultaneous read and write transactions</li></ul></li><li>• FPGA-to-HPS Bridge<ul style="list-style-type: none"><li>• Allows IP bus masters in the logic core to access to HPS bus slaves</li><li>• Configurable 32-, 64-, or 128-bit AMBA AXI interface</li><li>• Up to three masters within the core fabric can share the HPS SDRAM controller with the processor</li></ul></li><li>• HPS-to-FPGA Bridge<ul style="list-style-type: none"><li>• Allows HPS bus masters to access bus slaves in core fabric</li><li>• Configurable 32-, 64-, or 128-bit Avalon<sup>®</sup>/AMBA AXI interface allows high-bandwidth HPS master transactions to logic core</li></ul></li><li>• Configuration Bridge<ul style="list-style-type: none"><li>• Allows configuration manager in HPS to configure the logic core under program control via dedicated 32-bit configuration port</li></ul></li><li>• Light Weight HPS-to-FPGA Bridge<ul style="list-style-type: none"><li>• Light weight 32-bit AXI interface suitable for low-latency register accesses from HPS to soft peripherals in logic core</li></ul></li><li>• FPGA-to-HPS SDRAM controller Bridge<ul style="list-style-type: none"><li>• Up to three masters (command ports), 3x 64-bit read data ports, and 3x 64-bit write data ports</li></ul></li></ul>

# Arria 10 Block Diagrams

Figure 2: Arria 10 FPGA Architecture Block Diagram

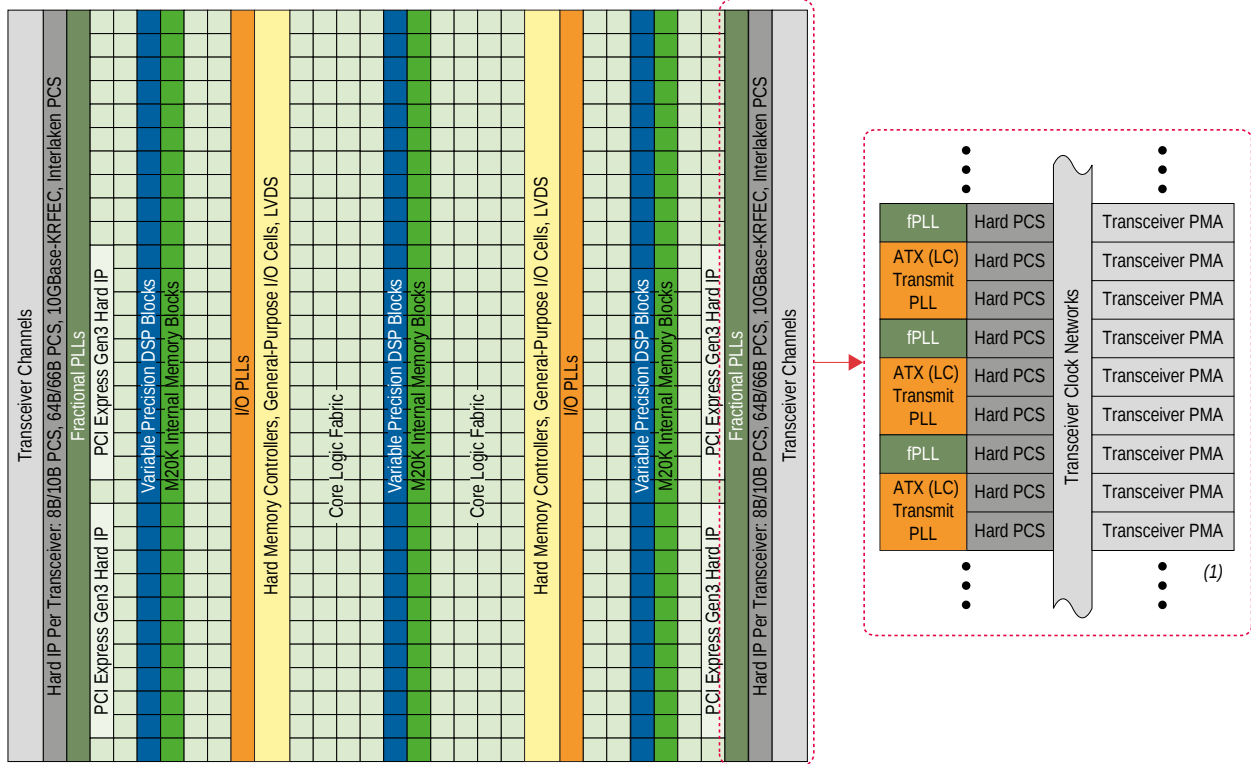

Note:  
(1) Unused transceiver channels can be used as additional transceiver transmit PLLs

Figure 3: Arria 10 SoC Architecture Block Diagram

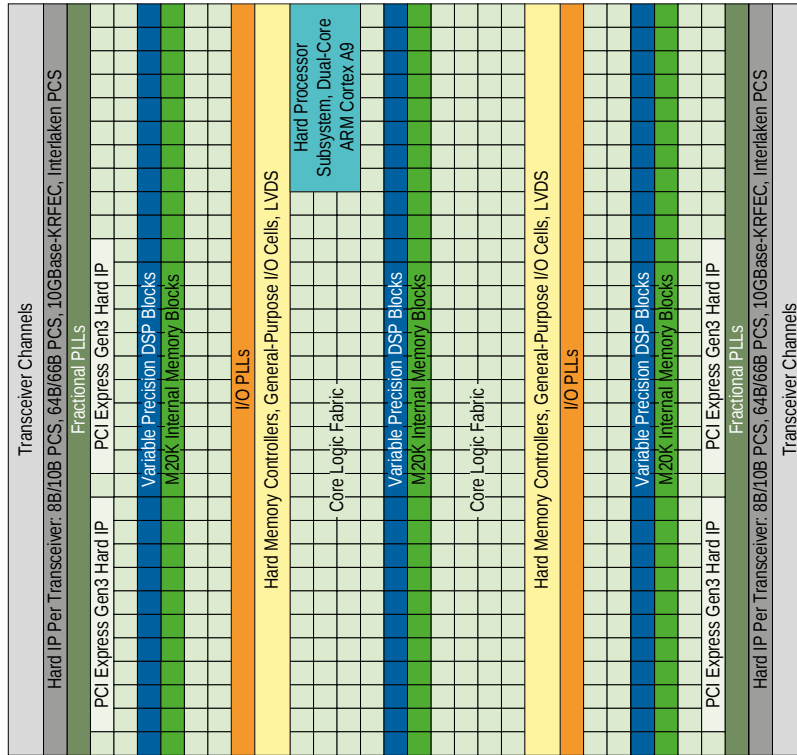

## Arria 10 FPGA Family Plan

Table 4: Arria 10 GX and Arria 10 GT FPGA Family Plan

Device Name <sup>(1)</sup>	Logic Elements (KLE)	Registers	M20K Blocks	M20K Mbits	MLAB Counts	MLAB Mbits	18x19 Multipliers <sup>(2)</sup>	Maximum GPIOs	Maximum XCVR (17.4G, 28.05G)	fPLLs	I/O PLLs	PCIe HIPs
GX 160 (10AX016)	160	246,040	440	9	1,680	1	312	288	12, 0	6	6	1
GX 220 (10AX022)	220	326,040	583	11	2,227	1	384	288	12, 0	6	6	1
GX 270 (10AX027)	270	406,480	750	15	3,968	2	1,660	384	24, 0	8	8	2

<sup>(1)</sup> The text in parentheses is the part number reference for this device.

<sup>(2)</sup> The number of 27x27 multipliers is one-half the number of 18x19 multipliers.

Device Name <sup>(1)</sup>	Logic Elements (KLE)	Registers	M20K Blocks	M20K Mbits	MLAB Counts	MLAB Mbits	18x19 Multipliers <sup>(2)</sup>	Maximum GPIOs	Maximum XCVR (17.4G, 28.05G)	fPLLs	I/O PLLs	PCIe HIPs
GX 320 (10AX032)	320	478,640	891	17	4,673	3	1,970	384	24, 0	8	8	2
GX 480 (10AX048)	480	730,880	1,438	28	7,137	4	2,736	492	36, 0	12	12	2
GX 570 (10AX057)	570	868,320	1,800	35	8,241	5	3,046	588	48, 0	16	16	2
GX 660 (10AX066)	660	1,005,800	2,133	42	9,345	6	3,356	588	48, 0	16	16	2
GX 900 (10AX090)	900	1,358,480	2,423	47	15,080	9	3,036	768	96, 0	32	16	4
GX 1150 (10AX115)	1,150	1,710,800	2,713	53	20,814	13	3,036	768	96, 0	32	16	4
GT 900 (10AT090)	900	1,358,480	2,423	47	15,080	9	3,036	624	80, 16	32	16	4
GT 1150 (10AT115)	1,150	1,710,800	2,713	53	20,814	13	3,036	624	80, 16	32	16	4

**Table 5: Arria 10 GX and Arria 10 GT FPGA Family Package Plan, part 1**

Cell legend: General Purpose I/Os, High-Voltage I/Os, LVDS Pairs, Transceivers <sup>(3) (4) (5) (6) (7) (8)</sup>

Device <sup>(1)</sup>	U19 (U484) (19x19 mm <sup>2</sup> )	F27 (F672) (27x27 mm <sup>2</sup> )	F29 (F780) (29x29 mm <sup>2</sup> )	F34 (F1152) (35x35 mm <sup>2</sup> )	F35 (F1152) (35x35 mm <sup>2</sup> ) <sup>(9)</sup>	F36 (F1152) (35x35 mm <sup>2</sup> ) <sup>(9)</sup>
GX 160 (10AX016)	192,48,72,6	240,48,96,12	288,48,120,12	—	—	—

<sup>(3)</sup> All packages are ball grid arrays with 1.0 mm pitch, except for U19 (U484), which is 0.8 mm pitch.

<sup>(4)</sup> High-Voltage I/O pins are used for 3.3 V and 2.5 V interfacing.

<sup>(5)</sup> Each LVDS pair can be configured as either a differential input or a differential output.

<sup>(6)</sup> High-Voltage I/O pins and LVDS pairs are included in the General Purpose I/O count. Transceivers are counted separately.

<sup>(7)</sup> Each package column offers pin migration (common circuit board footprint) for all devices in the column.

<sup>(8)</sup> Arria 10 GX devices are pin migratable with Arria 10 GT devices in the same package.

<sup>(9)</sup> Devices in the F35 (F1152) package are pin migratable with devices in the F36 (F1152) package

Device <sup>(1)</sup>	U19 (U484) (19x19 mm <sup>2</sup> )	F27 (F672) (27x27 mm <sup>2</sup> )	F29 (F780) (29x29 mm <sup>2</sup> )	F34 (F1152) (35x35 mm <sup>2</sup> )	F35 (F1152) (35x35 mm <sup>2</sup> ) <sup>(9)</sup>	F36 (F1152) (35x35 mm <sup>2</sup> ) <sup>(9)</sup>
GX 220 (10AX022)	192,48,72,6	240,48,96,12	288,48,120,12	—	—	—
GX 270 (10AX027)	—	240,48,96,12	360,48,156,12	384,48,168,24	384,48,168,24	—
GX 320 (10AX032)	—	240,48,96,12	360,48,156,12	384,48,168,24	384,48,168,24	—
GX 480 (10AX048)	—	—	360,48,156,12	492,48,222,24	396,48,174,36	—
GX 570 (10AX057)	—	—	—	492,48,222,24	396,48,174,36	—
GX 660 (10AX066)	—	—	—	492,48,222,24	396,48,174,36	432,48,192,36
GX 900 (10AX090)	—	—	—	528,0,264,24	432,0,216,36	—
GX 1150 (10AX115)	—	—	—	528,0,264,24	432,0,216,36	—
GT 900 (10AT090)	—	—	—	—	—	—
GT 1150 (10AT115)	—	—	—	—	—	—

**Table 6: Arria 10 GX and Arria 10 GT FPGA Family Package Plan, part 2**

Cell legend: General Purpose I/Os, High-Voltage I/Os, LVDS Pairs, Transceivers <sup>(3) (4) (5) (6) (7) (8)</sup>

Device <sup>(1)</sup>	F40 (F1517) (40x40 mm <sup>2</sup> )	F40 (F1517) (40x40 mm <sup>2</sup> )	F45 (F1932) (45x45 mm <sup>2</sup> )	F45 (F1932) (45x45 mm <sup>2</sup> )	F45 (F1932) (45x45 mm <sup>2</sup> )
GX 160 (10AX016)	—	—	—	—	—
GX 220 (10AX022)	—	—	—	—	—

Device <sup>(1)</sup>	F40 (F1517) (40x40 mm <sup>2</sup> )	F40 (F1517) (40x40 mm <sup>2</sup> )	F45 (F1932) (45x45 mm <sup>2</sup> )	F45 (F1932) (45x45 mm <sup>2</sup> )	F45 (F1932) (45x45 mm <sup>2</sup> )
GX 270 (10AX027)	—	—	—	—	—
GX 320 (10AX032)	—	—	—	—	—
GX 480 (10AX048)	—	—	—	—	—
GX 570 (10AX057)	588,48,270,48	—	—	—	—
GX 660 (10AX066)	588,48,270,48	—	—	—	—
GX 900 (10AX090)	624,0,312,48	342,0,154,66	768,0,384,48	624,0,312,72	480,0,240,96
GX 1150 (10AX115)	624,0,312,48	342,0,154,66	768,0,384,48	624,0,312,72	480,0,240,96
GT 900 (10AT090)	624,0,312,48	—	—	624,0,312,72	480,0,240,96
GT 1150 (10AT115)	624,0,312,48	—	—	624,0,312,72	480,0,240,96



## Arria 10 SoC Family Plan

Table 7: Arria 10 SX SoC Family Features

SoC Subsystem	Feature	Available in all Arria 10 SoC Devices
<b>Hard Processor System</b>	Central processing unit (CPU) core	Dual-core ARM Cortex-A9 MPCore processor with ARM CoreSight debug and trace technology
	Co-processors	Vector Floating-point unit (VFPU) single and double precision, ARM NEON media processing engine for each processor Snoop control unit (SCU), Acceleration coherency port (ACP)
	Layer 1 Cache	32 KB L1 instruction cache, 32 KB L1 data cache
	Layer 2 Cache	512 KB Shared L2 Cache
	On-Chip Memory	256 KB On-Chip RAM, 64 KB On-chip ROM
	Direct memory access (DMA) controller	8-Channel DMA
	Ethernet media access controller (EMAC)	Three 10/100/1000 EMAC with integrated DMA
	USB On-The-Go controller (OTG)	2 USB OTG with integrated DMA
	UART controller	2 UART 16550 compatible
	Serial Peripheral Interface (SPI) controller	4 SPI
	I <sup>2</sup> C controller	5 I <sup>2</sup> C controllers
	QSPI flash controller	1 SIO, DIO, QIO SPI flash supported
	SD/SDIO/MMC controller	1 eMMC 4.5 with DMA and CE-ATA support
	NAND flash controller	1 ONFI 1.0 or later 8 and 16 bit support
	General-purpose I/O (GPIO)	Maximum of 62 software programmable GPIO
	Timers	7 general-purpose timers, 4 watchdog timers
Security	Secure boot, Advanced Encryption Standard (AES) and authentication (SHA)	
<b>External Memory Interface</b>	External Memory Interface	Hard Memory Controller with DDR4 and DDR3

Table 8: Arria 10 SX SoC Family Plan

Device Name <sup>(10)</sup>	Logic Elements (KLE)	Registers	M20K Blocks	M20K Mbits	MLAB Counts	MLAB Mbits	18x19 Multipliers <sup>(11)</sup>	Maximum GPIOs	Maximum XCVR (17.4G, 28.05G)	fPLLs	I/O PLLs	PCIe HIPs
SX 160 (10AS016)	160	246,040	440	9	1,680	1	312	288	12, 0	6	6	1
SX 220 (10AS022)	220	326,040	583	11	2,227	1	384	288	12, 0	6	6	1
SX 270 (10AS027)	270	406,480	750	15	3,968	2	1,660	384	24, 0	8	8	2
SX 320 (10AS032)	320	478,640	891	17	4,673	3	1,970	384	24, 0	8	8	2
SX 480 (10AS048)	480	730,880	1,438	28	7,137	4	2,736	492	36, 0	12	12	2
SX 570 (10AS057)	570	868,320	1,800	35	8,241	5	3,046	588	48, 0	16	16	2
SX 660 (10AS066)	660	1,005,800	2,133	42	9,345	6	3,356	588	48, 0	16	16	2

<sup>(10)</sup> The text in parentheses is the part number reference for this device.

<sup>(11)</sup> The number of 27x27 multipliers is one-half the number of 18x19 multipliers.

**Table 9: Arria 10 SX SoC Family Package Plan**Cell legend: General Purpose I/Os, High-Voltage I/Os, LVDS Pairs, Transceivers <sup>(12)</sup> <sup>(13)</sup> <sup>(14)</sup> <sup>(15)</sup> <sup>(16)</sup>

Device <sup>(10)</sup>	U19 (U484) (19x19 mm <sup>2</sup> )	F27 (F672) (27x27 mm <sup>2</sup> )	F29 (F780) (29x29 mm <sup>2</sup> )	F34 (F1152) (35x35 mm <sup>2</sup> )	F35 (F1152) (35x35 mm <sup>2</sup> ) <sup>(17)</sup>	F36 (F1152) (35x35 mm <sup>2</sup> ) <sup>(17)</sup>  72-bit HPS DDR	F40 (F1517) (40x40 mm <sup>2</sup> )
SX 160 (10AS016)	192,48,72,6	240,48,96,12	288,48,120,12	—	—	—	—
SX 220 (10AS022)	192,48,72,6	240,48,96,12	288,48,120,12	—	—	—	—
SX 270 (10AS027)	—	240,48,96,12	360,48,156,12	384,48,168,24	384,48,168,24	—	—
SX 320 (10AS032)	—	240,48,96,12	360,48,156,12	384,48,168,24	384,48,168,24	—	—
SX 480 (10AS048)	—	—	360,48,156,12	492,48,222,24	396,48,174,36	—	—
SX 570 (10AS057)	—	—	—	492,48,222,24	396,48,174,36	—	588,48,270,48
SX 660 (10AS066)	—	—	—	492,48,222,24	396,48,174,36	432,48,192,36	588,48,270,48

## Migration Between Arria 10 Devices and Stratix 10 Devices

You can start developing with Arria 10 devices and then move to Stratix 10 devices, because there is footprint compatibility between the Arria 10 and Stratix 10 packages. Contact Altera for more details about the migration possibilities between the two device families.

<sup>(12)</sup> All packages are ball grid arrays with 1.0 mm pitch, except for U19 (U484), which is 0.8 mm pitch.

<sup>(13)</sup> High-Voltage I/O pins are used for 3.3 V and 2.5 V interfacing.

<sup>(14)</sup> Each LVDS pair can be configured as either a differential input or a differential output.

<sup>(15)</sup> High-Voltage I/O pins and LVDS pairs are included in the General Purpose I/O count. Transceivers are counted separately.

<sup>(16)</sup> Each package column offers pin migration (common circuit board footprint) for all devices in the column.

<sup>(17)</sup> Devices in the F35 (F1152) package are pin migratable with devices in the F36 (F1152) package

## Arria 10 Low Power Serial Transceivers

Arria 10 FPGAs and SoCs provide the lowest power transceivers for applications where power efficiency is paramount, while still delivering high bandwidth, throughput, and low latency.

Arria 10 transceivers feature data rates from 125 Mbps to 28.05 Gbps for chip-to-chip and chip-to-module applications. In addition, for long reach and backplane applications, advanced adaptive equalization is available for driving backplanes at data rates up to 17.4 Gbps. Lower power modes are also available at data rates up to 11.3 Gbps for critical power sensitive designs.

The combination of 20 nm process technology and architectural advances provide a significant reduction of die area and power consumption. Arria 10 transceivers allow for up to a 2X increase in transceiver I/O density compared to previous generation devices while maintaining optimal signal integrity. Arria 10 devices offer up to 96 total transceiver channels. Up to 16 of these channels can be configured to run up to 28.05 Gbps to drive next generation 100G interfaces and CFP2/CFP4 optical modules. All channels feature continuous data rate support up to the maximum rated speed.

**Figure 4: Arria 10 Transceiver Block Architecture**

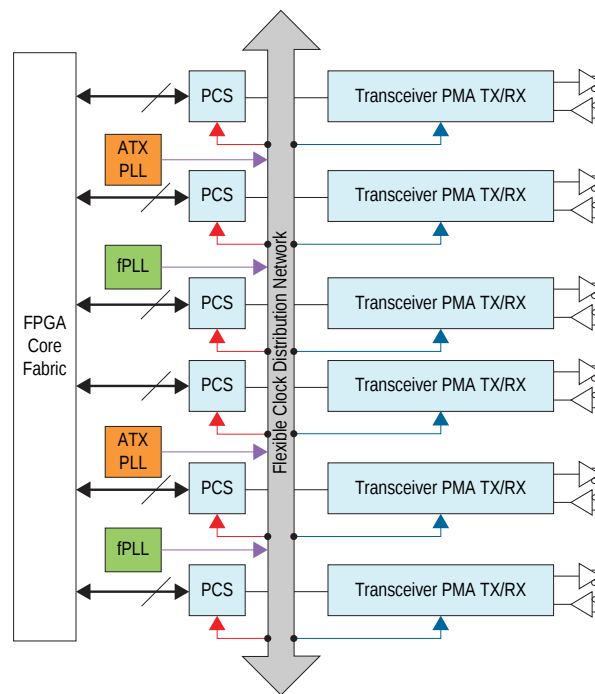

All transceiver channels feature a dedicated Physical Medium Attachment (PMA) and a hardened Physical Coding Sublayer (PCS).

- The PMA provides primary interfacing capabilities to physical channels.
- The PCS typically handles encoding/decoding, word alignment, and other pre-processing functions before transferring data to the FPGA core fabric.

Transceivers are segmented into blocks of six PMA-PCS groups. A wide variety of bonded and non-bonded data rate configurations are possible using a highly configurable clock distribution network. Up to 80 independent transceiver data rates can be configured.

## PMA Features

PMA channels are comprised of transmitter (TX), receiver (RX), and high speed clocking resources.

Arria 10 TX features provide exceptional signal integrity at data rates up to 28.05 Gbps. Clocking options include ultra-low jitter ATX (inductor-capacitor) PLLs, channel PLLs, clock multiplier unit (CMU) PLLs, and fractional PLLs (fPLLs):

- ATX PLLs can be configured in integer mode, or optionally, in a new fractional frequency synthesis mode. Each ATX PLL spans the full frequency range of the supported data rate range providing a highly stable and flexible clock source with the lowest jitter.
- CMU PLLs have been enhanced to provide a master clock source within the transceiver bank.
- When not configured as a transceiver channel, select PMA channels can be optionally configured as ring oscillator-based channel PLLs to provide an additional flexible clock source.
- In addition, dedicated on-chip fractional PLLs (fPLLs) are available with precision frequency synthesis capabilities. fPLLs can be used to synthesize multiple clock frequencies from a single reference clock source and replace multiple reference oscillators for multi-protocol and multi-rate applications.

**Figure 5: Arria 10 Transmitter Features**

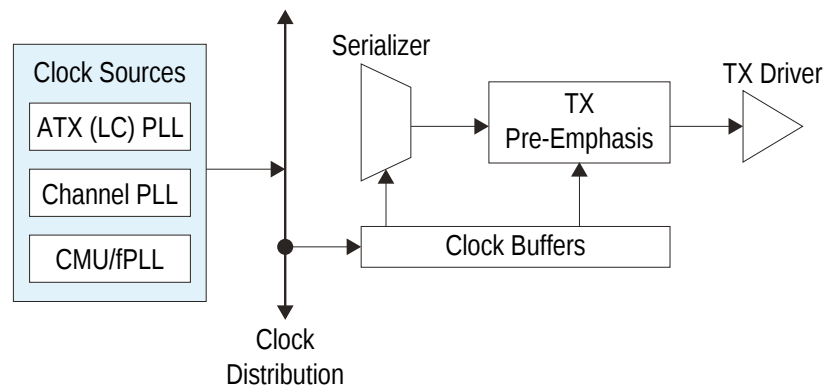

On the receiver side, each PMA channel has a dedicated, independent channel PLL for the CDR to provide the maximum number of clocking resources possible without compromising TX clocking sources. Up to 80 independent data rates can be configured on a single Arria 10 device.

Receiver side features provide unparalleled equalization capabilities to drive a wide range of transmission media with the widest range of protocols and data rates. Each receiver channel includes:

- Continuous Time Linear Equalizers (CTLE)—to compensate for channel losses with low power
- Variable Gain Amplifiers (VGA)—to optimize the receiver's dynamic range
- Decision Feedback Equalizers (DFE)—with 7-fixed taps and 4-floating taps to provide additional equalization capability on backplanes even in the presence of crosstalk and reflections

In addition, On-Die Instrumentation (ODI) provides on-chip eye monitoring capabilities (EyeQ). This capability helps to both optimize link equalization parameters during board bring-up and provide in-system link diagnostics. Combined with on-chip jitter injection capabilities, EyeQ provides powerful functionality to do in-system link equalization margin testing.

Figure 6: Arria 10 Receiver Block Features

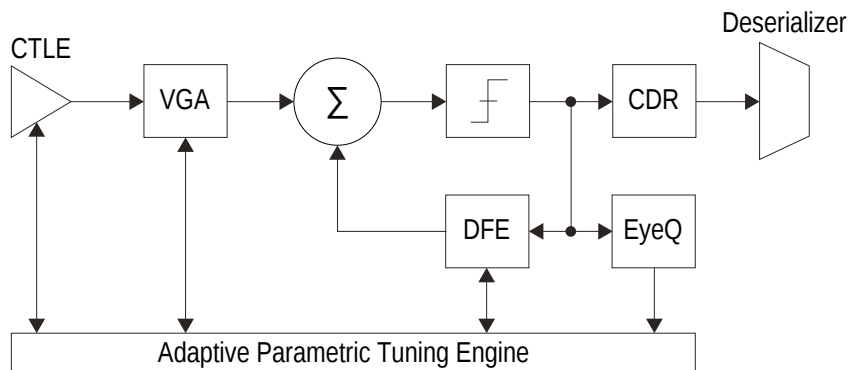

All link equalization parameters feature automatic adaptation using the new Altera Digital Adaptive Parametric Tuning (ADAPT) block to dynamically set DFE tap weights, CTLE, VGA Gain, and threshold voltages. Finally, optimal and consistent signal integrity is ensured by using the new hardened Precision Signal Integrity Calibration Engine (PreSICE) to automatically calibrate all transceiver circuit blocks on power-up to give the most link margin and ensure robust, reliable, and error-free operation.

Table 10: Arria 10 Transceiver PMA Features

Feature	Capability
Chip-to-Chip Data Rates	125 Mbps to 17.4 Gbps (Arria 10 GX devices) 125 Mbps to 28.05 Gbps (Arria 10 GT devices)
Backplane Support	Drive backplanes at data rates up to 17.4 Gbps, including 10GBASE-KR compliance
Optical Module Support	SFP+/SFP, XFP, CXP, QSFP/QSFP28, CFP/CFP2/CFP4
Cable Driving Support	SFP+ Direct Attach, PCI Express over cable, eSATA
Transmit Pre-Emphasis	5-tap transmit pre-emphasis and de-emphasis to compensate for system channel loss
Continuous Time Linear Equalizer (CTLE)	Dual mode, high-gain, and high-data rate, linear receive equalization to compensate for system channel loss
Decision Feedback Equalizer (DFE)	7-fixed and 4-floating tap DFE to equalize backplane channel loss in the presence of crosstalk and noisy environments
Altera Digital Adaptive Parametric Tuning (ADAPT)	Fully digital adaptation engine to automatically adjust all link equalization parameters—including CTLE, DFE, and VGA blocks—that provide optimal link margin without intervention from user logic
Precision Signal Integrity Calibration Engine (PreSICE)	Hardened calibration controller to quickly calibrate all transceiver control parameters on power-up, which provides the optimal signal integrity and jitter performance
ATX Transmit PLLs	Low jitter ATX (inductor-capacitor) transmit PLLs with continuous tuning range to cover a wide range of standard and proprietary protocols

Feature	Capability
Fractional PLLs	On-chip fractional frequency synthesizers to replace on-board crystal oscillators and reduce system cost
Digitally Assisted Analog CDR	Superior jitter tolerance with fast lock time
On-Die Instrumentation— EyeQ and Jitter Margin Tool	Simplify board bring-up, debug, and diagnostics with non-intrusive, high-resolution eye monitoring (EyeQ). Also inject jitter from transmitter to test link margin in system.
Dynamic Partial Reconfiguration (DPRIO)	Allows for independent control of each transceiver channel Avalon memory-mapped interface for the most transceiver flexibility
Multiple PCS-PMA and PCS-PLD interface widths	8-, 10-, 16-, 20-, 32-, 40-, or 64-bit interface widths for flexibility of deserialization width, encoding, and reduced latency

## PCS Features

Arria 10 PMA channels interface with core logic through configurable PCS interface layers.

Multiple gearbox implementations are available to decouple PCS and PMA interface widths. This feature provides the flexibility to implement a wide range of applications with 8-, 10-, 16-, 20-, 32-, 40-, or 64-bit interface widths. Arria 10 FPGAs contain PCS hard IP to support a wide range of standard and proprietary protocols.

The Standard PCS mode provides support for 8B/10B encoded applications up to 12.5 Gbps. The Enhanced PCS mode supports applications up to 17.4 Gbps. In addition, for highly customized implementations, a PCS Direct mode provides a fixed width interface up to 64 bits wide to core logic to allow for custom encoding including support for standards up to 28.05 Gbps.

The enhanced PCS includes an integrated 10GBASE-KR/40GBASE-KR4 Forward Error Correction (FEC) block.

The following table lists some of the key PCS features of Arria 10 transceivers that can be used in a wide range of standard and proprietary protocols from 125 Mbps to 28.05 Gbps.

**Table 11: Arria 10 Transceiver PCS Features**

PCS Protocol Support	Data Rate (Gbps)	Transmitter Data Path	Receiver Data Path
Standard PCS	0.125 to 12.5	Phase compensation FIFO, byte serializer, 8B/10B encoder, bit-slipper, channel bonding	Rate match FIFO, word-aligner, 8B/10B decoder, byte deserializer, byte ordering
PCI Express Gen1/Gen2 x1, x4, x8	2.5 and 5.0	Same as Standard PCS plus PIPE 2.0 interface to core	Same as Standard PCS plus PIPE 2.0 interface to core

PCS Protocol Support	Data Rate (Gbps)	Transmitter Data Path	Receiver Data Path
PCI Express Gen3 x1, x4, x8	8.0	Phase compensation FIFO, byte serializer, encoder, scrambler, bit-slipper, gear box, channel bonding, and PIPE 3.0 interface to core, auto speed negotiation	Rate match FIFO (0-600 ppm mode), word-aligner, decoder, descrambler, phase compensation FIFO, block sync, byte deserializer, byte ordering, PIPE 3.0 interface to core, auto speed negotiation
CPRI	0.6144 to 9.8	Same as Standard PCS plus deterministic latency serialization	Same as Standard PCS plus deterministic latency deserialization
Enhanced PCS	2.5 to 17.4	FIFO, channel bonding, bit-slipper, and gear box	FIFO, block sync, bit-slipper, and gear box
10GBASE-R	10.3125	FIFO, 64B/66B encoder, scrambler, FEC, and gear box	FIFO, 64B/66B decoder, descrambler, block sync, FEC, and gear box
Interlaken	4.9 to 17.4	FIFO, channel bonding, frame generator, CRC-32 generator, scrambler, disparity generator, bit-slipper, and gear box	FIFO, CRC-32 checker, frame sync, descrambler, disparity checker, block sync, and gear box
SFI-S/SFI-5.2	11.3	FIFO, channel bonding, bit-slipper, and gear box	FIFO, bit-slipper, and gear box
IEEE 1588	1.25 to 10.3125	FIFO (fixed latency), 64B/66B encoder, scrambler, and gear box	FIFO (fixed latency), 64B/66B decoder, descrambler, block sync, and gear box
SDI	up to 11.9	FIFO and gear box	FIFO, bit-slipper, and gear box
GigE	1.25	Same as Standard PCS plus GigE state machine	Same as Standard PCS plus GigE state machine
PCS Direct	up to 28.05	Custom	Custom

## PCI Express Gen1/Gen2/Gen3 Hard IP

Arria 10 devices contain embedded PCI Express hard IP designed for performance, ease-of-use, and increased functionality.

The PCI Express hard IP consists of the PHY, Data Link, and Transaction layers, and supports PCI Express Gen1/Gen2/Gen3 end point and root port, in x1/x2/x4/x8 lane configurations. The PCI Express hard IP is capable of operating independently from the core logic. This feature allows the link to power up and complete link training in less than 100 ms, while the Arria 10 device completes loading the programming file for the rest of the FPGA. The hard IP also provides added functionality, which makes it easier to support emerging features such as Single Root I/O Virtualization (SR-IOV) and optional protocol extensions. The Arria 10 PCI Express hard IP has improved end-to-end data path protection using Error Checking and Correction (ECC). In addition, the hard IP supports configuration of the FPGA via protocol across the PCI Express bus at Gen1/Gen2/Gen3 rates (CvP using PCI Express).



## Interlaken PCS Hard IP

Arria 10 devices have integrated Interlaken PCS hard IP supporting rates up to 17.4 Gbps per lane.

The Interlaken PCS hard IP is based on the proven functionality of the PCS developed for Altera's previous generation FPGAs, which has demonstrated interoperability with Interlaken ASSP vendors and third-party IP suppliers. The Interlaken PCS hard IP is present in every transceiver channel in Arria 10 devices.

## 10G Ethernet Hard IP

Arria 10 devices include IEEE 802.3 10-Gbps Ethernet (10GbE) compliant 10GBASE-R PCS and PMA hard IP. The scalable 10GbE hard IP supports multiple independent 10GbE ports while using a single PLL for all the 10GBASE-R PCS instantiations, which saves on core logic resources and clock networks.

The integrated 10G serial transceivers simplify multi-port 10GbE systems compared to XAUI interfaces that require an external XAUI-to-10G PHY. Furthermore, the integrated 10G transceivers incorporate Electronic Dispersion Compensation (EDC), which enables direct connection to standard 10G XFP and SFP+ pluggable optical modules. The 10G transceivers also support backplane Ethernet applications and include a hard 10GBASE-KR Forward Error Correction (FEC) circuit that can be used for both 10G and 40G applications. The integrated 10G Ethernet hard IP and 10G transceivers save external PHY cost, board space, and system power. The 10G Ethernet PCS hard IP and 10GBASE-KR FEC are present in every transceiver channel.

## External Memory and General Purpose I/O

Arria 10 devices offer massive external memory bandwidth, with up to seven 32-bit DDR4 memory interfaces running at up to 2666 Mbps.

This bandwidth provides additional ease of design, lower power, and resource efficiencies of hardened high-performance memory controllers. Memory interfaces can be configured up to a maximum width of 144 bits when using either hard or soft memory controllers. Arria 10 devices also feature general purpose I/O capable of supporting a wide range of single-ended and differential I/O interfaces. LVDS rates up to 1.6 Gbps are supported, with each pair of pins having both a differential driver and a differential input buffer allowing for configurable LVDS direction on each pair.

The memory interface within Arria 10 FPGAs and SoCs delivers the highest performance and ease of use. Each I/O bank contains 48 general purpose I/Os and a high-efficiency hard memory controller capable of supporting many different memory types, each with different performance capabilities. The hard memory controller is also capable of being bypassed and replaced by a soft controller implemented in the user logic. The I/Os each have a hardened DDR read/write path (PHY) capable of performing key memory interface functionality such as read/write leveling, FIFO buffering to lower latency and improve margin, timing calibration, and on-chip termination. The timing calibration is aided by the inclusion of hard microcontrollers based on Altera's Nios<sup>®</sup> II technology, specifically tailored to control the calibration of multiple memory interfaces. This calibration allows the Arria 10 device to compensate for any changes in process, voltage, or temperature either within the Arria 10 device itself, or within the external memory device. The advanced calibration algorithms ensure maximum bandwidth and robust timing margin across all operating conditions.

**Table 12: Arria 10 External Memory Interface Performance**

The listed speeds are for the 1-rank case.

Interface	Controller Type	Performance
DDR4	Hard	2666 Mbps

Interface	Controller Type	Performance
DDR3	Hard	2133 Mbps
QDR II+ / II+ Xtreme	Soft	550 MTps
RLDRAM III	Hard	2400 Mbps
RLDRAM II	Soft	533 Mbps

In addition to parallel memory interfaces, Arria 10 devices support serial memory technologies such as the Hybrid Memory Cube (HMC). The HMC is supported by the Arria 10 high-speed serial transceivers, which connect up to four HMC links, with each link running at data rates up to 15 Gbps.

## Adaptive Logic Module (ALM)

Arria 10 devices use the same adaptive logic module (ALM) as the previous generation Arria V and Stratix V FPGAs, allowing for efficient implementation of logic functions and easy conversion of IP between the devices.

The ALM block diagram shown in the following figure has eight inputs with a fracturable look-up table (LUT), two dedicated embedded adders, and four dedicated registers.

Figure 7: Arria 10 FPGA and SoC ALM Block Diagram

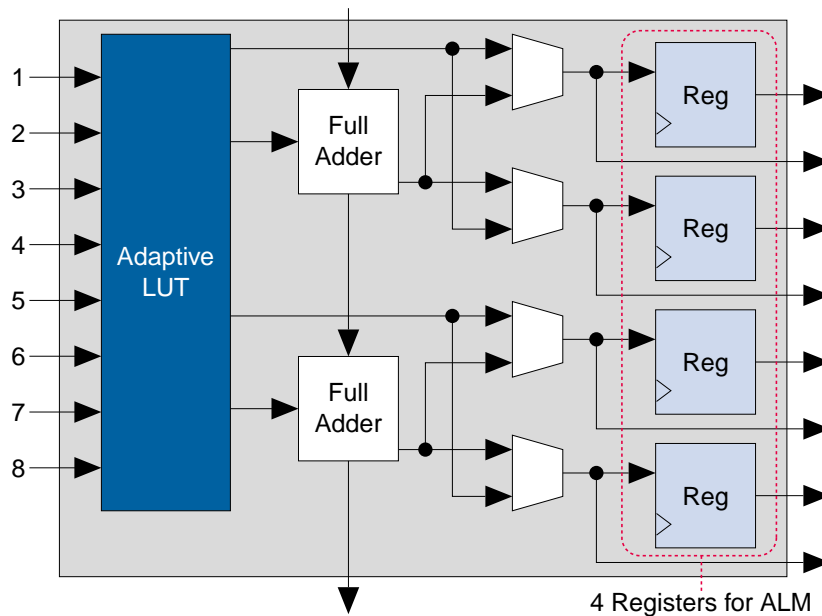

Key features and capabilities of the Arria 10 ALM include:

- High register count with 4 registers per 8-input fracturable LUT enables Arria 10 devices to maximize core performance at higher core logic utilization
- 6% more logic compared to the traditional 2-register per LUT architecture
- Implements select 7-input logic functions, all 6-input logic functions, and two independent functions consisting of smaller LUT sizes (such as two independent 4-input LUTs) to optimize core logic utilization

The Quartus II software leverages the Arria 10 ALM logic structure to deliver the highest performance, optimal logic utilization, and lowest compile times. The Quartus II software simplifies design reuse as it automatically maps legacy designs into the Arria 10 ALM architecture.

## Core Clocking

The Arria 10 device core clock network supports over 500 MHz fabric operation across the full industrial temperature range, and supports the hard memory controllers up to 2666 Mbps with a quarter rate transfer.

The clock network architecture is based on Altera's proven global, regional, and periphery clock structure, which is supported by dedicated clock input pins, fractional clock synthesis PLLs, and integer I/O PLLs. All unused sections of the clock network are identified by the Quartus II software and are powered down to reduce dynamic power consumption.

## Fractional Synthesis PLLs and I/O PLLs

Arria 10 devices have up to 32 fractional synthesis PLLs (fPLL) and up to 16 I/O PLLs (IOPLL) that are available for both specific and general purpose use in the core.

The fPLLs are located in columns adjacent to the transceiver blocks. They can be used to reduce both the number of oscillators required on the board and the number of clock pins required, by synthesizing multiple clock frequencies from a single reference clock source. In addition to synthesizing reference clock frequencies for the transceiver CMU and ATX (LC) transmit PLLs, the fPLLs can be used for clock network delay compensation, zero-delay buffering, and direct transmit clocking for transceivers. Each fPLL may be independently configured for conventional integer mode, which is equivalent to a general purpose PLL (GPLL), or enhanced fractional mode with third-order delta-sigma modulation.

The integer mode IOPLLs are located in each bank of 48 I/Os. They can be used to simplify the design of external memory interfaces and high-speed LVDS interfaces. The IOPLLs are adjacent to the hard memory controllers and LVDS SERDES in each I/O bank, making it easier to close timing because these PLLs are tightly coupled with the I/Os that need to use them. Like the fPLLs, the IOPLLs can be used for general purpose applications in the core such as clock network delay compensation and zero-delay buffering.

## Internal Embedded Memory

Arria 10 devices contain two types of embedded memory blocks: MLAB (640-bit) and M20K (20-Kbit).

The MLAB blocks are ideal for wide and shallow memories. The M20K blocks are double the size of the M10K blocks used in the previous generation Arria V devices, and are useful for supporting larger memory configurations and include hard ECC. Both types of embedded memory block can be configured as a single-port or dual-port RAM, FIFO, ROM or shift register. These memory blocks are highly flexible and support a number of memory configuration as shown in the following table.

**Table 13: Arria 10 Internal Embedded Memory Block Configurations**

MLAB (640 bits)	M20K (20 Kbits)
64 x 10 (supported through emulation)	16K x 1
32 x 20	8K x 2
	4K x 5
	2K x 10
	1K x 20
	512 x 40

The Quartus II software simplifies design reuse by automatically mapping memory blocks from previous generations of devices into the Arria 10 MLAB and M20K blocks.

## Variable Precision DSP Block

The Arria 10 DSP blocks are based upon the Variable Precision DSP Architecture used in Altera's previous generation Arria V FPGAs. The blocks can be configured to natively support signal processing with precision ranging from 18x19 up to 54x54. A pipeline register has been added to increase the maximum operating frequency of the DSP block and reduce power consumption.

Each DSP block can be independently configured at compile time as either dual 18x19 or a single 27x27 multiply accumulate. With a dedicated 64-bit cascade bus, multiple variable precision DSP blocks can be cascaded to implement even higher precision DSP functions efficiently. The following table shows how different precisions are accommodated within a DSP block, or by utilizing multiple blocks.

**Table 14: Variable Precision DSP Block Configurations**

Multiplier Size	DSP Block Resources	Expected Usage
18x19 bits	1/2 of Variable Precision DSP Block	Medium precision fixed point
27x27 bits	1 Variable Precision DSP Block	High precision fixed or Single Precision floating point
19x36 bits	1 Variable Precision DSP Block with external adder	Fixed point FFTs
36x36 bits	2 Variable Precision DSP Blocks with external adder	Very high precision fixed point
54x54 bits	4 Variable Precision DSP Blocks with external adder	Double Precision floating point

Complex multiplication is very common in DSP algorithms. One of the most popular applications of complex multipliers is the FFT algorithm. This algorithm has the characteristic of increasing precision requirements on only one side of the multiplier. The Variable Precision DSP block supports the FFT algorithm with proportional increase in DSP resources as the precision grows.

**Table 15: Complex Multiplication With Variable Precision DSP Block**

Complex Multiplier Size	DSP Block Resources	FFT Usage
18x19 bits	2 Variable Precision DSP Blocks	Resource optimized FFTs
27x27 bits	4 Variable Precision DSP Blocks	Highest precision FFT stages and single precision floating point

For FFT applications with high dynamic range requirements, the Altera FFT MegaCore<sup>®</sup> function offers an option of single precision floating point implementation, with resource usage and performance similar to high precision fixed point implementations.

Other features of the DSP block include:

- Hard 18-bit and 25-bit pre-adders
- 64-bit dual accumulator (for separate I, Q product accumulations)
- Cascaded output adder chains for 18- and 27-bit FIR filters
- Embedded coefficient registers for 18- and 27-bit coefficients
- Fully independent multiplier outputs
- Inferability using HDL templates supplied by the Quartus II software for most modes

The Variable Precision DSP block is ideal to support the growing trend towards higher bit precision in high performance DSP applications. At the same time, it can efficiently support the many existing 18-bit DSP applications, such as high definition video processing and remote radio heads. Arria 10 devices, with the Variable Precision DSP block architecture, can efficiently support many different precision levels, up to and including floating point implementations. This flexibility can result in increased system performance, reduced power consumption, and reduce architecture constraints on system algorithm designers.

## Hard Processor System (HPS)

The 20-nm HPS strikes a balance between enabling maximum software compatibility with 28-nm SoCs while still improving upon the 28-nm HPS architecture. These improvements address the requirements of the next generation target markets such as wireless and wireline communications, compute and storage equipment, broadcast and military in terms of performance, memory bandwidth, connectivity via backplane and security.

Figure 8: HPS Block Diagram

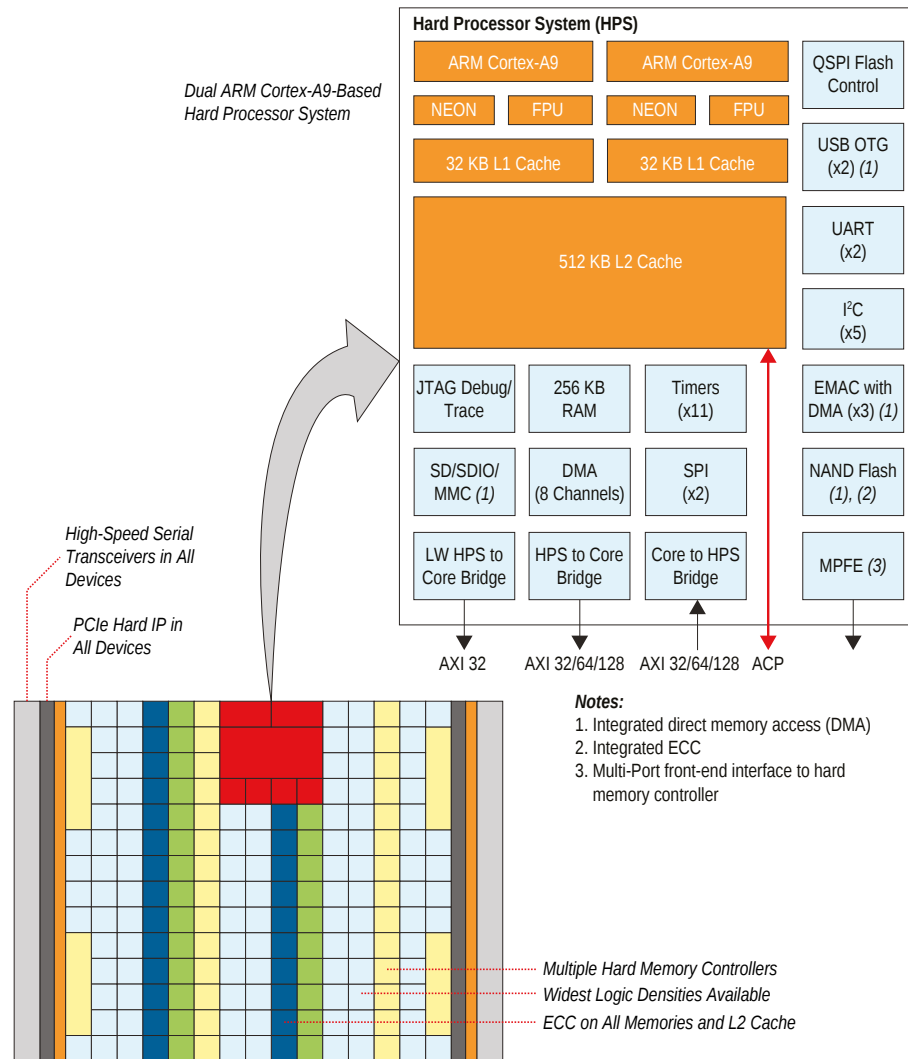

The HPS has the following features:

- 1.2-GHz, dual-core ARM Cortex-A9 MPCore processor with up to 1.5-GHz via overdrive
  - ARMv7-A architecture and runs 32-bit ARM instructions, 16-bit and 32-bit Thumb instructions, and 8-bit Java byte codes in Jazelle style
  - Superscalar, variable length, out-of-order pipeline with dynamic branch prediction
  - Instruction Efficiency 2.5 MIPS/MHz, at 1.5 GHz total performance of 7500 MIPS
- Each processor core includes:
  - 32 KB of L1 instruction cache, 32 KB of L1 data cache
  - Single- and double-precision floating-point unit and NEON media engine
  - CoreSight debug and trace technology
  - Snoop Control Unit (SCU) and Acceleration Coherency Port (ACP)
- 512 KB of shared L2 cache
- 256 KB of scratch RAM

- Hard memory controller with support for DDR3, DDR4 and optional error correction code (ECC) support
- Multiport Front End (MPFE) Scheduler interface to the hard memory controller
- 8-channel direct memory access (DMA) controller
- QSPI flash controller with SIO, DIO, QIO SPI Flash support
- NAND flash controller (ONFI 1.0 or later) with DMA and ECC support, updated to support 8 and 16-bit Flash devices and new command DMA to offload CPU for fast power down recovery
- Updated SD/SDIO/MMC controller to eMMC 4.5 with DMA with CE-ATA digital command support
- 3 10/100/1000 Ethernet media access control (MAC) with DMA
- 2 USB On-the-Go (OTG) controller with DMA
- 5 I<sup>2</sup>C controller (3 can be used by EMAC for MIO to external PHY)
- 2 UART 16550 Compatible
- 4 serial peripheral interface (SPI) (2 Master, 2 Slaves)
- 54 programmable general-purpose I/O (GPIO)
- 48 I/O direct share I/O allows HPS peripherals to connect directly to I/O
- 7 general-purpose timers
- 4 watchdog timers
- Anti-tamper, Secure Boot, Encryption (AES) and Authentication (SHA)

## Key Features of 20-nm HPS

The following features are new in the 20-nm Hard Processor System compared to the 28-nm SoCs:

- **Increased Performance and Overdrive Capability**

While the nominal processor frequency is 1.2 GHz, the 20 nm HPS offers an “overdrive” feature which enables an even higher processor operating frequency. For this a higher supply voltage value is required that is unique to the HPS and may require a separate regulator.

- **Increased Processor Memory Bandwidth and DDR4 Support**

Up to 64-bit DDR4 memory @ 2666 Mbps is available for the processor. The hard memory controller for the HPS comprises a multi-port front end that manages connections to a single port memory controller. The multi-port front end allows logic core and the HPS share ports and thereby the available bandwidth of the memory controller.

- **Flexible I/O Sharing**

An advanced I/O pin muxing scheme allows improved sharing of I/O between the HPS and the core logic. The following types of I/O are available for SoC:

**Dedicated I/O (15)**—These I/Os are physically located inside the HPS block and are not accessible to logic within the core. The 15 dedicated I/Os are used for HPS clock, resets, and interfacing with boot devices, QSPI, and SD/MMC

**Direct Shared I/O (48)**—These shared I/Os are located closest to the HPS block and are ideal for high speed HPS peripherals such as EMAC, USB, and others. There is one bank of 48 I/Os that supports direct sharing where the 48 I/Os can be shared 12 I/Os at a time.

**Standard (Shared) I/O (All other)**—All standard I/Os can be shared by the HPS peripherals and any logic within the core. For designs where more than 48 I/Os are required to fully use all the peripherals in the HPS, these I/Os can be connected through the core logic.

- **EMAC Core**

A third EMAC core is available in the HPS. Three EMAC cores enable an application to support two redundant Ethernet connections; for example, backplane, or two EMAC cores for managing IEEE 1588 time stamp information while allowing a third EMAC core for debug and configuration. All three EMACs can potentially share the same time stamps, simplifying the 1588 time stamping implementation. A new serial time stamp interface allows core logic to access and read the time stamp values. The integrated EMAC controllers can be connected to external Ethernet PHY through the provided MDIO or I<sup>2</sup>C interface.

- **On-Chip Memory**

The on-chip memory is updated to 256 KB support and can support larger data sets and real time algorithms

- **ECC Enhancements**

Improvements in L2 Cache ECC management allow identification of errors down to the address level. ECC enhancements also enable improved error injection and status reporting via the introduction of new memory mapped access to syndrome and data signals.



- **HPS to FPGA Interconnect Backbone**

Although the HPS and the Logic Core can operate independently, they are tightly coupled via a high-bandwidth system interconnect built from high-performance ARM AMBA AXI bus bridges. IP bus masters in the FPGA fabric have access to HPS bus slaves via the FPGA-to-HPS interconnect. Similarly, HPS bus masters have access to bus slaves in the core fabric via the HPS-to-FPGA bridge. Both bridges are AMBA AXI-3 compliant and support simultaneous read and write transactions. Up to three masters within the core fabric can share the HPS SDRAM controller with the processor. Additionally, the processor can be used to configure the core fabric under program control via a dedicated 32-bit configuration port.

- **HPS-to-FPGA**—configurable 32-, 64-, or 128-bit Avalon/AMBA AXI interface allows high bandwidth HPS master transactions to Logic Core
- **LW HPS-to-FPGA**—Light Weight 32-bit AXI interface suitable for low latency register accesses from HPS to soft peripherals in logic core
- **FPGA-to-HPS**—configurable 32-, 64-, or 128-bit AMBA AXI interface
- **FPGA-to-HPS SDRAM controller**—up to 3 masters (command ports), 3x 64-bit read data ports and 3x 64-bit write data ports
- **32-bit FPGA configuration manager**
- **Security**

A number of new security features have been introduced for anti-tamper management, secure boot, encryption (AES), and authentication (SHA).

## Power Management

Arria 10 devices leverage the advanced 20 nm process technology, a low 0.9 V core power supply, an enhanced core architecture, and several optional power reduction techniques to reduce total power consumption by as much as 40% compared to Arria V devices and as much as 60% compared to Stratix V devices.

The optional power reduction techniques in Arria 10 devices include:

- **SmartVoltage ID**—a code is programmed into each device during manufacturing that allows a smart regulator to operate the device at lower core  $V_{CC}$  while maintaining performance
- **Programmable Power Technology**—non-critical timing paths are identified by the Quartus II software and the logic in these paths is biased for low power instead of high performance
- **$V_{CC}$  PowerManager**—allows devices to be run at lower core voltage to trade performance for power savings
- **Low Static Power Options**—devices are available with either standard static power or low static power while maintaining performance

Furthermore, Arria 10 devices feature Altera's industry-leading low power transceivers and include a number of hard IP blocks that not only reduce logic resources but also deliver substantial power savings compared to soft implementations. In general, hard IP blocks consume up to 50% less power than the equivalent soft logic implementations.

## Incremental Compilation

The Quartus II software incremental compilation feature reduces compilation time by up to 70% and preserves performance to ease timing closure.

Incremental compilation supports top-down, bottom-up, and team-based design flows. The incremental compilation feature facilitates modular hierarchical and team-based design flows where different designers compile their respective sections of a design in parallel. Furthermore, different designers or IP providers

can develop and optimize different blocks of the design independently. These blocks can then be imported into the top level project. The incremental compilation feature enables the partial reconfiguration flow for Arria 10 devices.

## Configuration and Configuration via Protocol Using PCI Express

Arria 10 device configuration is improved for ease-of-use, speed, and cost. The devices can be configured through a variety of techniques such as active and passive serial, fast passive parallel, JTAG, and configuration via protocol using PCI Express including Gen3.

Configuration via protocol (CvP) using PCI Express allows the FPGA to be configured across the PCI Express bus, simplifying the board layout and increasing system integration. Making use of the embedded PCI Express hard IP, this technique allows the PCI Express bus to be powered up and active within the 100 ms time allowed by the PCI Express specification. Arria 10 devices also support partial reconfiguration across the PCI Express bus which reduces system down time by keeping the PCI Express link active while the device is being reconfigured.

**Table 16: Arria 10 Device Configuration Modes**

Mode	Compression	Encryption	Remote Update	Data Width (bits)	Maximum DCLK Rate (MHz)	Maximum Data Rate (Mbps)
Active Serial	Yes	Yes	Yes	1, 4	100	400
Passive Serial	Yes	Yes	—	1	125	125
Passive Parallel	Yes	Yes	Parallel flash loader	8, 16, 32	125	4000
Configuration via PCI Express	—	Yes	Yes	1, 2, 4, 8	—	4000
JTAG	—	—	—	1	33	33

## Partial and Dynamic Reconfiguration

Partial reconfiguration allows you to reconfigure part of the FPGA while other sections continue running. This capability is required in systems where uptime is critical, because it allows you to make updates or adjust functionality without disrupting services.

In addition to lowering power and cost, partial reconfiguration also increases the effective logic density by removing the necessity to place in the FPGA those functions that do not operate simultaneously. Instead, these functions can be stored in external memory and loaded as needed. This reduces the size of the required FPGA by allowing multiple applications on a single FPGA, saving board space and reducing power. The partial reconfiguration process is built on top of the proven incremental compile design flow in the Quartus II design software.

Partial reconfiguration in Arria 10 devices is supported through the following configuration options:

- Partial reconfiguration through the FPP x16 I/O interface
- Partial reconfiguration using PCI Express

Dynamic reconfiguration in Arria 10 devices allows transceiver data rates, protocols and analog settings to be changed dynamically on a channel-by-channel basis while maintaining data transfer on adjacent transceiver channels. Dynamic reconfiguration is ideal for applications that require on-the-fly multi-protocol or multi-rate support, and both the PMA and PCS blocks within the transceiver can be reconfigured using this technique. Dynamic reconfiguration of the transceivers can be used in conjunction with partial reconfiguration of the FPGA to enable partial reconfiguration of both core and transceivers simultaneously.

## Single Event Upset (SEU) Error Detection and Correction

Arria 10 devices offer robust and easy-to-use SEU error detection and correction circuitry.

The detection and correction circuitry includes protection for Configuration RAM (CRAM) programming bits and user memories. The CRAM is protected by a continuously running CRC error detection circuit with integrated ECC that automatically corrects one or two errors and detects higher order multi-bit errors. When more than two errors occur, correction is available through reloading of the core programming file, providing a complete design refresh while the FPGA continues to operate.

The physical layout of the Arria 10 CRAM array is optimized to make the majority of multi-bit upsets appear as independent single-bit or double-bit errors which are automatically corrected by the integrated CRAM ECC circuitry. In addition to the CRAM protection, the user memories also include integrated ECC circuitry and are layout optimized for error detection and correction.

## Appendix: Arria 10 SoC Developers Corner

Altera's Arria 10 SoCs provide the combined benefits of programmable logic for high-speed data paths with ARM processor for intelligent control functions:

- High performance programmable core logic, hard memory controllers and high speed transceivers can be used to implement data path centric functions for 40G/100G systems including functions such as framing, bridging, aggregation, switching, traffic management, FEC, multirate aggregation, and data transmission.
- The integrated ARM based HPS implements intelligent control function and eliminates the need for a local processor, thereby reducing system power, form factor, and BOM cost. By adding intelligence to the data path, software on the ARM HPS manages and reduces system downtime and reduces the associated operating expenses. The Dual Core ARM Cortex-A9 based HPS comes with a rich set of embedded peripherals and associated device drivers for wide range of operating systems including Linux and VxWorks. The resulting board support packages can be used as the basis of a number of software applications such as:
  - Operations, Administration and Maintenance (OAM)
  - PCIe Root Port management
  - Remote Debug and System Update
  - Host offload and Algorithm acceleration
  - Chassis management
  - Routing and Look up management
  - Error handling and system downtime management
  - Rule management for deep packet inspection, packet parsing
  - Audio and Video Processing

## Altera SoC: The Architecture of Choice When Productivity Matters

Productivity is the driving philosophy of Altera's Arria 10 SoC family. By reusing hardware, software, IP, and RTL across FPGAs and SoCs, you can reduce design effort and get products to market faster. The Dual Core ARM Cortex-A9 MPCore-based HPS is common to both 20- and 28-nm SoCs and facilitates extensive software code compatibility as well as tools and OS Board Support Package (BSP) reuse. The extensive tools and OS support available as part of Altera and ARM ecosystem and the fast iteration times inherent in software development (especially as compared to FPGA compile times) results in a highly productive embedded and DSP development flow. In addition, Altera offers high-level automated design flows for hardware development, such as the Altera OpenCL (a C-based hardware design flow) and DSP Builder (a model-based hardware design flow).

**Figure 9: Hardware and Software Reuse**

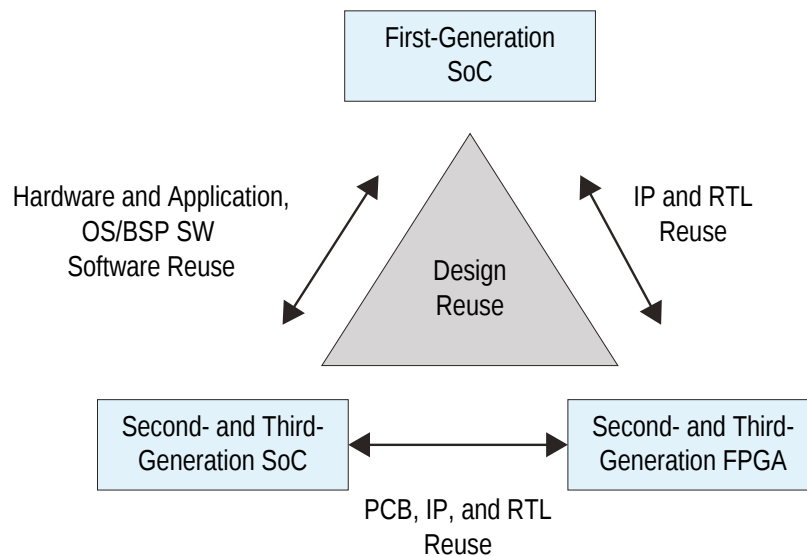

Altera's 20-nm SoCs and FPGAs can be reused in the following ways:

- **Application Code Reuse:** Because 28 nm and 20 nm SoCs share the same Dual Core ARM Cortex-A9 based HPS, any application code, board support packages, and ARM development tools developed for one SoC family can be reused with minimal design effort.
- **IP Reuse:** Arria 10 SoCs share the same core logic, memory, DSP, and I/O as Arria 10 FPGAs. Hardware intellectual property can be shared with minimal design effort. Altera also provides a fully tested and characterized portfolio of over 200 IP cores.
- **PCB Hardware Reuse:** Arria 10 SoCs are also package and footprint compatible with Arria 10 FPGAs, allowing hardware PCBs to be shared between the device categories.
- **Advanced Software Development Tools:**
  - The ecosystem that is available on ARM and the body of software packages, middleware available for operating systems that support ARM as well as the application development and debug tools available for ARM provides a familiar development environment to software developers.
  - Innovations such as Altera's Virtual Target technology allow functional testing of code without the need for hardware. By combining the most advanced multi-core debugger for ARM architectures with FPGA-adaptivity, the ARM DS-5 Altera Edition Toolkit provides embedded software developers an unprecedented level of full-chip visibility and control through the standard DS-5 user interface.
- **Advanced Hardware Development Tools:**
  - Altera's Quartus II software has faster compilation times than ever before. The Quartus II software's support for partial reconfiguration technology allows a single PCB to support multiple protocols by swapping protocols in the field.
  - QSys System Development framework allows rapid system integration of processor and peripherals and automates the process of generating AXI and Avalon based interconnect logic.
  - DSP Builder is a plug-in to MathWorks' Simulink that allows designers to develop DSP based filters, matrix operators and transforms using Model Based design flow and Advanced Blockset tools.
  - Open Computing Language (OpenCL) programming model with Altera's massively parallel FPGA architecture provides a powerful solution for system acceleration. The Altera SDK for OpenCL allows software developers to develop hardware using a C-based high-level design flow.

## Single Platform of Devices that Offer Unified Control Path and Scalable Datapath

When you combine the SoC portfolio with the productivity benefits of design reuse in hardware and software, you get a benefit that is unique to Altera's technology. The result is an architecture that offers both unified control path and scalable data path.

Figure 10: Unified Control Path and Scalable Data Path

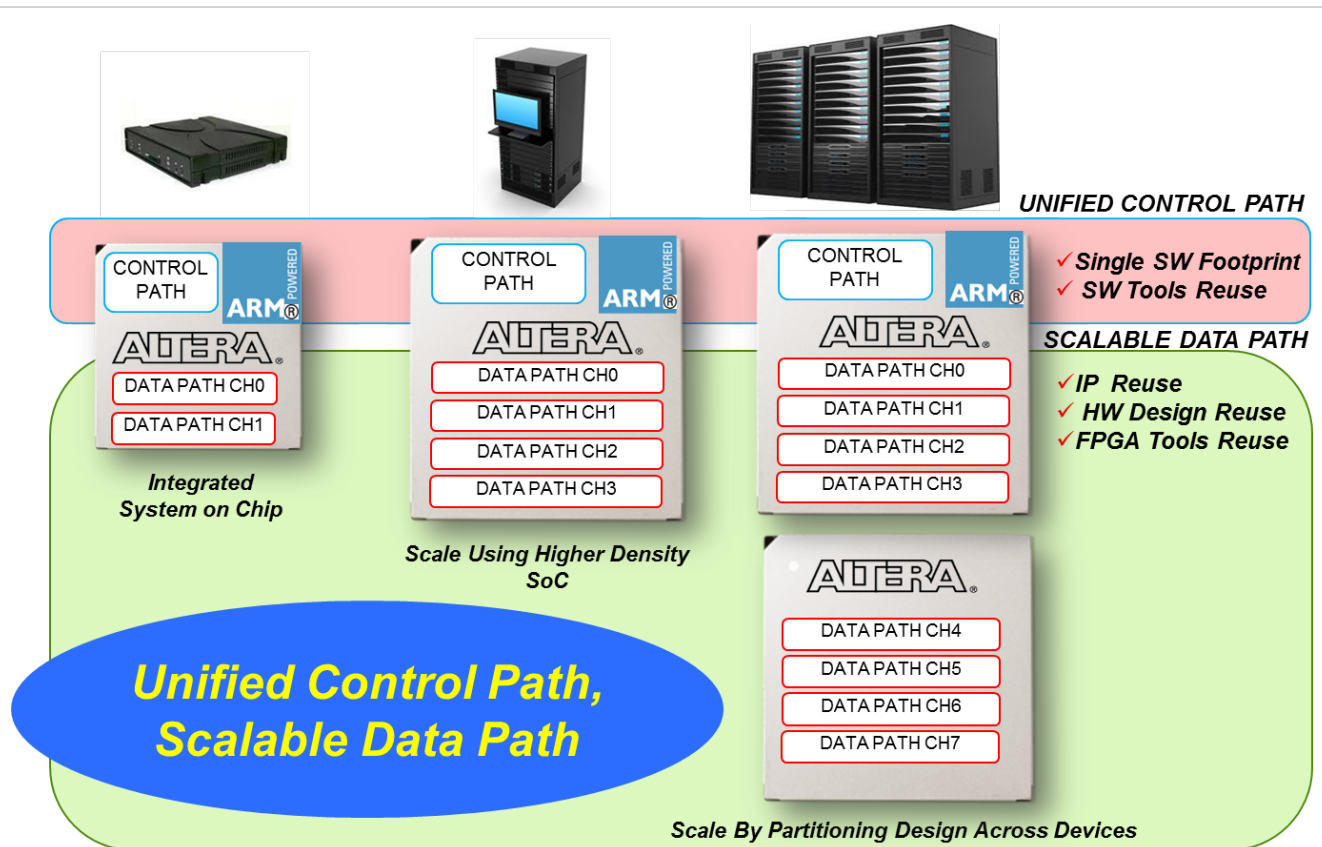

SoCs and FPGAs can be used across product platforms from low cost customer premise equipment to metro and access service provider equipment all the way to core and transmission equipment. For example, the low-cost Cyclone<sup>®</sup> V SoC offers a fully integrated system-on-a-chip device for the low end of a product portfolio that is ideal for customer premise, small cell routers, and enterprise routing. On the other end of the spectrum, Arria 10 and Stratix 10 SoCs offer performance and a high level of system integration on the high end of the product portfolio for access, networking, and transmission equipment.

**Unified Control:** Because all 28-nm and 20-nm SoCs feature a common Dual ARM Cortex-A9 based HPS, there is extensive software tool reuse, operating system board support packages (BSP) reuse and a high degree of software code compatibility across the devices and the end product portfolio.

**Scalable Datapath:** Altera's SoC offers a portfolio of devices that meet the price, power, performance, logic density, memory bandwidth, and transceiver bandwidth of an entire product portfolio. This scalability both simplifies the system architecture and enhances productivity through design reuse and protocol IP reuse.

## Differentiation through Customization

Designers today can choose between many competing technologies: off the shelf processors, ASSPs, ASICs, and SoCs. Altera's SoCs stand out from these competing technologies because they allow maximum customization. Designers can implement their intellectual property in software running on the ARM or in hardware running on the programmable logic. The high speed serial I/O and memory interfaces allow a high degree of customization and flexibility. Designers can choose a standard protocol or memory standard or they can implement a custom protocol or memory controller and still use the embedded PHY circuitry to bypass the controller logic. Altera offers fully characterized turnkey IP cores for a number of communication

interfaces, memories, and DSP functions, allowing Altera devices to offer the largest variety of interface and feature support than any off the shelf processor or ASSP. The design cycles for Altera’s SoCs are a fraction of ASIC design cycles and offer a much lower risk path compared to an ASIC.

**Figure 11: Differentiation through Customization**

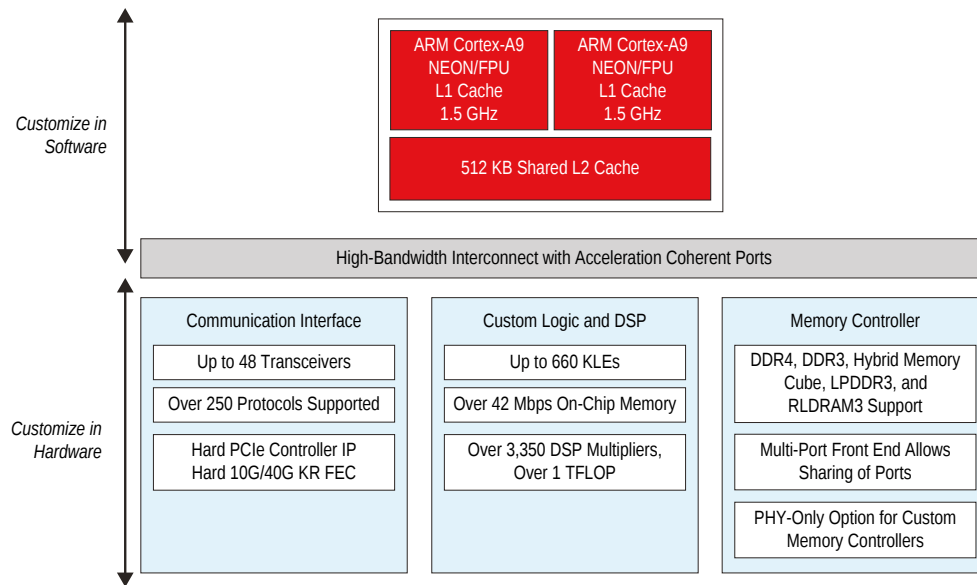

## A New, More Productive DSP Design Flow

With Altera’s SoCs, a more productive design flow for DSP design is now available. For the first time, DSP and embedded developers who may be unfamiliar to FPGA and HDL design can develop hardware and take advantage of the remarkable DSP performance available with Altera’s SoCs.

In this design flow, DSP and embedded developers begin by running DSP algorithms directly on the ARM HPS. This is a natural place to begin as, in many cases, C/C++ are the very languages in which these algorithms have been conceived in the first place. The Dual Core ARM Cortex-A9 MPCore features a double precision FPU and a NEON co-processor for 128-bit SIMD co-processor and is ideal for closed loop control, audio, video, and multimedia processing. The inherent productivity of software design cycles and iterations as compared to FPGA compilation times reduces system compile times drastically. When more performance is required, these software algorithms can be then profiled to identify bottlenecks and subsequently become candidates for hardware acceleration. Hardware accelerators can share data and computed results directly with ARM processor’s L2 Cache via the Acceleration Coherency Port (ACP) that manages data coherency without having to incur the penalty of a full L2 Cache flush.

To develop these hardware accelerators, Altera offers two high-level automated design tools:

- With Altera's **OpenCL design flow**, hardware accelerators are created by coding the algorithm in a C-based high-level language. Using an automatic compiler, instruction streams are then developed and implemented as hardware running on the SoC. In this case, the OpenCL host code is run directly on the Dual ARM processor whereas the OpenCL kernels are implemented as hardware accelerators running in the logic core. By having an integrated processor on chip, the need for an external host processor to implement OpenCL host code is eliminated. For more information about OpenCL and the design flow, refer to the *OpenCL for Altera FPGAs: Accelerating Performance and Design Productivity* page.
- With Altera's **DSP Builder technology**, system definition and simulation is performed using the industry-standard MathWorks Simulink tools. The DSP Builder Signal Compiler block reads Simulink Model Files (.mdl) that are built using DSP Builder and MegaCore blocks and generates VHDL files and Tcl scripts for synthesis, hardware implementation, and simulation. This technology allows the automatic generation timing-optimized register transfer level (RTL) code based on high-level Simulink design descriptions. This is a significant productivity savings compared to the hours or days required to hand-optimize HDL code. In addition, advanced blockset DSP Builder libraries are available for commonly used DSP operations and transforms. For more information, refer to the *DSP Builder* page.

#### Related Information

- [OpenCL for Altera FPGAs: Accelerating Performance and Design Productivity](#)
- [DSP Builder](#)

## Document Revision History

Table 17: Document Revision History

Date	Version	Changes
July 2013	2013.07.09	Added product names to tables in "Arria 10 FPGA Family Plan" and "Arria 10 SoC Family Plan" sections.
June 2013	2013.06.10	Initial release.



# AMEYA360

## Components Supply Platform

Authorized Distribution Brand :



Website :

Welcome to visit [www.ameya360.com](http://www.ameya360.com)

Contact Us :

➤ Address :

401 Building No.5, JiuGe Business Center, Lane 2301, Yishan Rd  
Minhang District, Shanghai , China

➤ Sales :

Direct +86 (21) 6401-6692

Email [amall@ameya360.com](mailto:amall@ameya360.com)

QQ 800077892

Skype [ameyasales1](#) [ameyasales2](#)

➤ Customer Service :

Email [service@ameya360.com](mailto:service@ameya360.com)

➤ Partnership :

Tel +86 (21) 64016692-8333

Email [mkt@ameya360.com](mailto:mkt@ameya360.com)