

MAX3243 3-V to 5.5-V Multichannel RS-232 Line Driver/Receiver With ± 15 -kV ESD (HBM) Protection

1 Features

- Operates With 3-V to 5.5-V V_{CC} Supply
- Single-Chip and Single-Supply Interface for IBM™ PC/AT™ Serial Port
- RS-232 Bus-Pin ESD Protection of ± 15 kV Using Human-Body Model (HBM)
- Meets or Exceeds the Requirements of TIA/EIA-232-F and ITU V.28 Standards
- Three Drivers and Five Receivers
- Operates Up To 250 kbit/s
- Low Active Current: 300 μ A Typical
- Low Standby Current: 1 μ A Typical
- External Capacitors: 4 \times 0.1 μ F
- Accepts 5-V Logic Input With 3.3-V Supply
- Always-Active Noninverting Receiver Output (ROUT2B)
- Operating Temperature
 - MAX3243C: 0°C to 70°C
 - MAX3243I: –40°C to 85°C
- Serial-Mouse Driveability
- Auto-Powerdown Feature to Disable Driver Outputs When No Valid RS-232 Signal Is Sensed

2 Applications

- Battery-Powered Systems
- Tablets
- Notebooks
- Laptops
- Hand-Held Equipment

3 Description

The MAX3243 device consists of three line drivers, five line receivers which is ideal for DE-9 DTE interface. ± 15 -kV ESD (HBM) protection pin to pin (serial- port connection pins, including GND). Flexible power features saves power automatically. Special outputs ROUT2B and INVALID are always enabled to allow checking for ring indicator and valid RS232 input.

Device Information⁽¹⁾

PART NUMBER	PACKAGE (PIN)	BODY SIZE
MAX3243	SSOP (28)	10.29 mm \times 5.30 mm
	SOIC (28)	17.90 mm \times 7.50 mm
	TSSOP (28)	9.70 mm \times 4.40 mm

(1) For all available packages, see the orderable addendum at the end of the data sheet.

4 Simplified Diagram

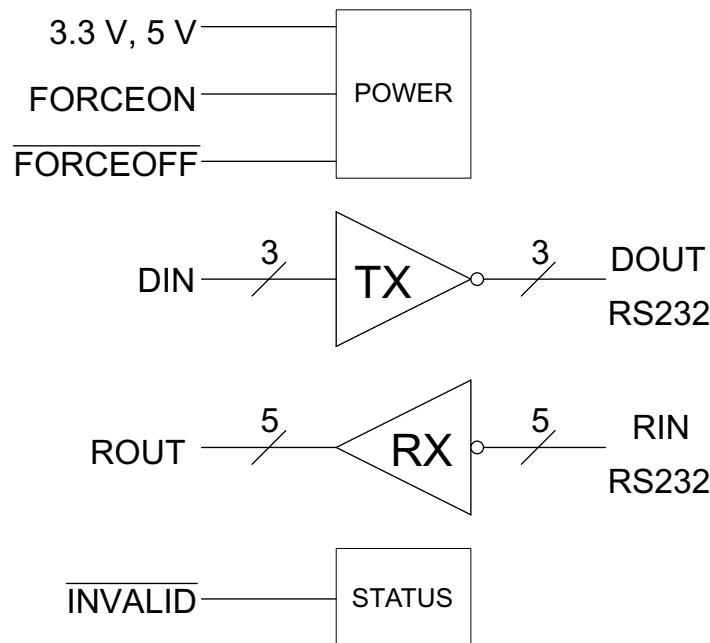

Table of Contents

1 Features	1	8 Parameter Measurement Information	8
2 Applications	1	9 Detailed Description	11
3 Description	1	9.1 Overview	11
4 Simplified Diagram	1	9.2 Functional Block Diagram	11
5 Revision History	2	9.3 Feature Description.....	12
6 Pin Configuration and Functions	3	9.4 Device Functional Modes.....	13
7 Specifications	4	10 Application and Implementation	14
7.1 Absolute Maximum Ratings	4	10.1 Application Information.....	14
7.2 ESD Ratings.....	4	10.2 Typical Application	14
7.3 Recommended Operating Conditions.....	4	11 Power Supply Recommendations	16
7.4 Thermal Information	4	12 Layout	16
7.5 Electrical Characteristics — Auto Power Down.....	5	12.1 Layout Guidelines	16
7.6 Electrical Characteristics — Driver	5	12.2 Layout Example	17
7.7 Electrical Characteristics — Receiver	6	13 Device and Documentation Support	18
7.8 Switching Characteristics — Auto Power Down	6	13.1 Trademarks	18
7.9 Switching Characteristics — Driver	6	13.2 Electrostatic Discharge Caution.....	18
7.10 Switching Characteristics — Receiver	6	13.3 Glossary	18
7.11 Typical Characteristics	7	14 Mechanical, Packaging, and Orderable Information	18

5 Revision History

Changes from Revision N (May 2009) to Revision O

Page

• Added <i>Applications</i> , <i>Device Information</i> table, <i>Pin Functions</i> table, <i>ESD Ratings</i> table, <i>Thermal Information</i> table, <i>Typical Characteristics</i> , <i>Feature Description</i> section, <i>Device Functional Modes</i> , <i>Application and Implementation</i> section, <i>Power Supply Recommendations</i> section, <i>Layout</i> section, <i>Device and Documentation Support</i> section, and <i>Mechanical, Packaging, and Orderable Information</i> section.	1
• Deleted <i>Ordering Information</i> table.	1

6 Pin Configuration and Functions

DB, DW, OR PW PACKAGE
(TOP VIEW)

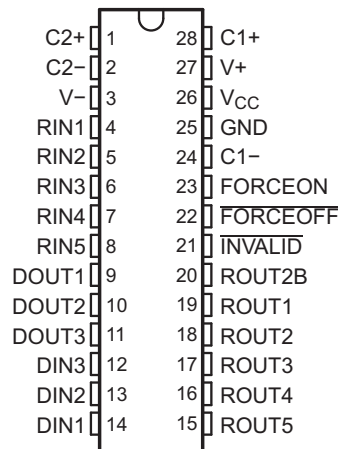

Pin Functions

PIN		TYPE	DESCRIPTION
NAME	NO.		
C2+	1	—	Positive lead of C2 capacitor
C2–	2	—	Negative lead of C2 capacitor
V–	3	O	Negative charge pump output for storage capacitor only
RIN1:RIN5	4, 5, 6, 7, 8	I	RS232 line data input (from remote RS232 system)
DOUT1:DOUT3	9, 10, 11	O	RS232 line data output (to remote RS232 system)
DIN3:DIN1	12, 13, 14	I	Logic data input (from UART)
ROUT5:ROUT1	15, 16, 17, 18, 19	O	Logic data output (to UART)
ROUT2B	20	O	Always Active non-inverting output for RIN2 (normally used for ring indicator)
$\overline{\text{INVALID}}$	21	O	Active low output when all RIN are unpowered
$\overline{\text{FORCEOFF}}$	22	I	Low input forces DOUT1-5, ROUT1-5 high Z per Device Functional Modes
FORCEON	23	I	High forces drivers on. Low is automatic mode per Device Functional Modes
C1–	24	—	Negative lead on C1 capacitor
GND	25	—	Ground
V _{CC}	26	—	Supply Voltage, Connect to 3V to 5.5V power supply
V+	27	O	Positive charge pump output for storage capacitor only
C1+	28	—	Positive lead of C1 capacitor

7 Specifications

7.1 Absolute Maximum Ratings

 over operating free-air temperature range (unless otherwise noted) ⁽¹⁾

		MIN	MAX	UNIT	
V _{CC}	Supply voltage range ⁽²⁾	-0.3	6	V	
V+	Positive output supply voltage range ⁽²⁾	-0.3	7	V	
V-	Negative output supply voltage range ⁽²⁾	0.3	-7	V	
V+ – V-	Supply voltage difference ⁽²⁾		13	V	
V _I	Input voltage range	Driver, $\overline{\text{FORCEOFF}}$, FORCEON	-0.3	6	V
		Receiver	-25	25	
V _O	Output voltage range	Driver	-13.2	13.2	V
		Receiver, $\overline{\text{INVALID}}$	-0.3	V _{CC} + 0.3	
T _J	Operating virtual junction temperature		150	°C	
T _{stg}	Storage temperature range	-65	150	°C	

(1) Stresses beyond those listed under *Absolute Maximum Ratings* may cause permanent damage to the device. These are stress ratings only, and functional operation of the device at these or any other conditions beyond those indicated under *Recommended Operating Conditions* is not implied. Exposure to absolute-maximum-rated conditions for extended periods may affect device reliability.

(2) All voltages are with respect to network GND.

7.2 ESD Ratings

			MAX	UNIT
V _(ESD)	Electrostatic discharge	Human body model (HBM), per ANSI/ESDA/JEDEC JS-001 RIN, DOUT, and GND pins ⁽¹⁾	15000	V
		Human body model (HBM), per ANSI/ESDA/JEDEC JS-001 All other pins ⁽¹⁾	3000	
		Charged device model (CDM), per JEDEC specification JESD22-C101, all pins ⁽²⁾	1000	

(1) JEDEC document JEP155 states that 500-V HBM allows safe manufacturing with a standard ESD control process.

(2) JEDEC document JEP157 states that 250-V CDM allows safe manufacturing with a standard ESD control process.

7.3 Recommended Operating Conditions

⁽¹⁾(See [Figure 8](#))

		MIN	NOM	MAX	UNIT	
V _{CC}	Supply voltage	V _{CC} = 3.3 V	3	3.3	3.6	V
		V _{CC} = 5 V	4.5	5	5.5	
V _{IH}	Driver and control high-level input voltage	DIN, $\overline{\text{FORCEOFF}}$, FORCEON			5.5	V
					5.5	
V _{IL}	Driver and control low-level input voltage	DIN, $\overline{\text{FORCEOFF}}$, FORCEON	0		0.8	V
V _I	Driver and control input voltage	DIN, $\overline{\text{FORCEOFF}}$, FORCEON	0		5.5	V
V _I	Receiver input voltage		-25		25	V
T _A	Operating free-air temperature	MAX3243C	0		70	°C
		MAX3243I	-40		85	

(1) Test conditions are C1–C4 = 0.1 μF at V_{CC} = 3.3 V ± 0.3 V; C1 = 0.047 μF, C2–C4 = 0.33 μF at V_{CC} = 5 V ± 0.5 V.

7.4 Thermal Information

THERMAL METRIC ⁽¹⁾	MAX3243			UNIT	
	DB	DW	PW		
	16 PINS	16 PINS	16 PINS		
R _{θJA}	Junction-to-ambient thermal resistance	62	46	62	°C/W

(1) For more information about traditional and new thermal metrics, see the *IC Package Thermal Metrics* application report ([SPRA953](#)).

7.5 Electrical Characteristics — Auto Power Down

over recommended ranges of supply voltage and operating free-air temperature (unless otherwise noted)⁽¹⁾ (see [Figure 8](#))

PARAMETER		TEST CONDITIONS	MIN	TYP ⁽²⁾	MAX	UNIT
I _{CC}	Supply current Auto-powerdown disabled	No load, $\overline{\text{FORCEOFF}}$ and FORCEON at V _{CC} . T _A = 25°C		0.3	1	mA
	Supply current Powered off	No load, $\overline{\text{FORCEOFF}}$ at GND. T _A = 25°C		1	10	μA
	Supply current Auto-powerdown enabled	No load, $\overline{\text{FORCEOFF}}$ at V _{CC} , FORCEON at GND, All RIN are open or grounded, All DIN are grounded. T _A = 25°C		1	10	
I _I	Input leakage current of $\overline{\text{FORCEOFF}}$, FORCEON	V _I = V _{CC} or V _I at GND		±0.01	±1	μA
V _{IT+}	Receiver input threshold for INVALID high-level output voltage	FORCEON = GND, $\overline{\text{FORCEOFF}}$ = V _{CC}			2.7	V
V _{IT-}	Receiver input threshold for INVALID high-level output voltage	FORCEON = GND, $\overline{\text{FORCEOFF}}$ = V _{CC}		-2.7		V
V _T	Receiver input threshold for INVALID low-level output voltage	FORCEON = GND, $\overline{\text{FORCEOFF}}$ = V _{CC}		-0.3	0.3	V
V _{OH}	INVALID high-level output voltage	I _{OH} = -1 mA, FORCEON = GND, $\overline{\text{FORCEOFF}}$ = V _{CC}		V _{CC} - 0.6		V
V _{OL}	INVALID low-level output voltage	I _{OL} = 1.6 mA, FORCEON = GND, $\overline{\text{FORCEOFF}}$ = V _{CC}			0.4	V

(1) Test conditions are C1–C4 = 0.1 μF at V_{CC} = 3.3 V ± 0.3 V; C1 = 0.047 μF, C2–C4 = 0.33 μF at V_{CC} = 5 V ± 0.5 V.

(2) Stresses beyond those listed under *Absolute Maximum Ratings* may cause permanent damage to the device. These are stress ratings only, and functional operation of the device at these or any other conditions beyond those indicated under *Recommended Operating Conditions* is not implied. Exposure to absolute-maximum-rated conditions for extended periods may affect device reliability.

7.6 Electrical Characteristics — Driver

over recommended ranges of supply voltage and operating free-air temperature (unless otherwise noted)⁽¹⁾ (see [Figure 8](#))

PARAMETER		TEST CONDITIONS	MIN	TYP ⁽²⁾	MAX	UNIT
V _{OH}	High-level output voltage	All DOUT at R _L = 3 kΩ to GND	5	5.4		V
V _{OL}	Low-level output voltage	All DOUT at R _L = 3 kΩ to GND	-5	-5.4		V
V _O	Output voltage (mouse driveability)	DIN1 = DIN2 = GND, DIN3 = V _{CC} , 3-kΩ to GND at DOUT3, DOUT1 = DOUT2 = 2.5 mA		±5		V
I _{IH}	High-level input current	V _I = V _{CC}		±0.01	±1	μA
I _{IL}	Low-level input current	V _I at GND		±0.01	±1	μA
V _{hys}	Input hysteresis				±1	V
I _{OS}	Short-circuit output current ⁽³⁾	V _{CC} = 3.6 V, V _O = 0 V		±35	±60	mA
		V _{CC} = 5.5 V, V _O = 0 V				
r _o	Output resistance	V _{CC} , V+, and V- = 0 V, V _O = ±2 V	300	10M		Ω
I _{off}	Output leakage current	$\overline{\text{FORCEOFF}}$ = GND,	V _O = ±12 V, V _{CC} = 3 to 3.6 V		±25	μA
			V _O = ±10 V, V _{CC} = 4.5 to 5.5 V			

(1) Test conditions are C1–C4 = 0.1 μF at V_{CC} = 3.3 V ± 0.3 V; C1 = 0.047 μF, C2–C4 = 0.33 μF at V_{CC} = 5 V ± 0.5 V.

(2) All typical values are at V_{CC} = 3.3 V or V_{CC} = 5 V, and T_A = 25°C.

(3) Short-circuit durations should be controlled to prevent exceeding the device absolute power dissipation ratings, and not more than one output should be shorted at a time.

7.7 Electrical Characteristics — Receiver

over recommended ranges of supply voltage and operating free-air temperature (unless otherwise noted)⁽¹⁾ (see [Figure 8](#))

PARAMETER		TEST CONDITIONS	MIN	TYP ⁽²⁾	MAX	UNIT
V _{OH}	High-level output voltage	I _{OH} = -1 mA	V _{CC} - 0.6	V _{CC} - 0.1		V
V _{OL}	Low-level output voltage	I _{OH} = 1.6 mA			0.4	V
V _{IT+}	Positive-going input threshold voltage	V _{CC} = 3.3 V		1.6	2.4	V
		V _{CC} = 5 V		1.9	2.4	
V _{IT-}	Negative-going input threshold voltage	V _{CC} = 3.3 V	0.6	1.1		V
		V _{CC} = 5 V	0.8	1.4		
V _{hys}	Input hysteresis (V _{IT+} - V _{IT-})			0.5		V
I _{off}	Output leakage current (except ROUT2B)	FORCEOFF = 0 V		±0.05	±10	µA
r _i	Input resistance	V _i = ±3 V or ±25 V	3	5	7	kΩ

(1) Test conditions are C1–C4 = 0.1 µF at V_{CC} = 3.3 V ± 0.3 V; C1 = 0.047 µF, C2–C4 = 0.33 µF at V_{CC} = 5 V ± 0.5 V.

(2) All typical values are at V_{CC} = 3.3 V or V_{CC} = 5 V, and T_A = 25°C.

7.8 Switching Characteristics — Auto Power Down

over recommended ranges of supply voltage and operating free-air temperature (unless otherwise noted) (see [Figure 7](#))

PARAMETER		TEST CONDITIONS	TYP ⁽¹⁾	UNIT
t _{valid}	Propagation delay time, low- to high-level output	V _{CC} = 5 V	1	µs
t _{invalid}	Propagation delay time, high- to low-level output	V _{CC} = 5 V	30	µs
t _{en}	Supply enable time	V _{CC} = 5 V	100	µs

(1) All typical values are at V_{CC} = 3.3 V or V_{CC} = 5 V, and T_A = 25°C.

7.9 Switching Characteristics — Driver

over recommended ranges of supply voltage and operating free-air temperature (unless otherwise noted)⁽¹⁾ (see [Figure 8](#))
MAX3243C, MAX3243I

PARAMETER		TEST CONDITIONS	MIN	TYP ⁽²⁾	MAX	UNIT
	Maximum data rate	R _L = 3 kΩ One DOUT switching, C _L = 1000 pF See Figure 3	150	250		kbit/s
t _{sk(p)}	Pulse skew ⁽³⁾	R _L = 3 kΩ to 7 kΩ C _L = 150 pF to 2500 pF See Figure 5		100		ns
SR(tr)	Slew rate, transition region (see Figure 3)	V _{CC} = 3.3 V, R _L = 3 kΩ to 7 kΩ	C _L = 150 pF to 1000 pF	6	30	V/µs
			C _L = 150 pF to 2500 pF	4	30	

(1) Test conditions are C1–C4 = 0.1 µF at V_{CC} = 3.3 V ± 0.3 V; C1 = 0.047 µF, C2–C4 = 0.33 µF at V_{CC} = 5 V ± 0.5 V.

(2) All typical values are at V_{CC} = 3.3 V or V_{CC} = 5 V, and T_A = 25°C.

(3) Pulse skew is defined as |t_{PLH} - t_{PHL}| of each channel of the same device.

7.10 Switching Characteristics — Receiver

over recommended ranges of supply voltage and operating free-air temperature (unless otherwise noted)⁽¹⁾

PARAMETER		TEST CONDITIONS	TYP ⁽²⁾	UNIT
t _{PLH}	Propagation delay time, low- to high-level output	C _L = 150 pF, See Figure 5	150	ns
t _{PHL}	Propagation delay time, high- to low-level output		150	ns
t _{en}	Output enable time	C _L = 150 pF, R _L = 3 kΩ, See Figure 6	200	ns
t _{dis}	Output disable time		200	ns
t _{sk(p)}	Pulse skew ⁽³⁾		See Figure 5	50

(1) Test conditions are C1–C4 = 0.1 µF at V_{CC} = 3.3 V ± 0.3 V; C1 = 0.047 µF, C2–C4 = 0.33 µF at V_{CC} = 5 V ± 0.5 V.

(2) All typical values are at V_{CC} = 3.3 V or V_{CC} = 5 V, and T_A = 25°C.

(3) Pulse skew is defined as |t_{PLH} - t_{PHL}| of each channel of the same device.

7.11 Typical Characteristics

$V_{CC} = 3.3\text{ V}$

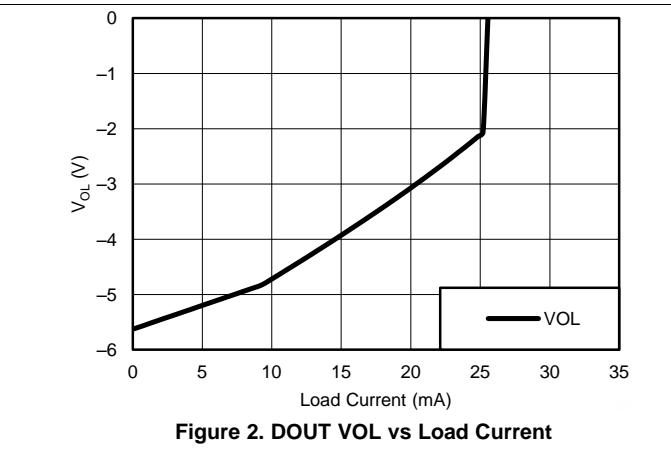
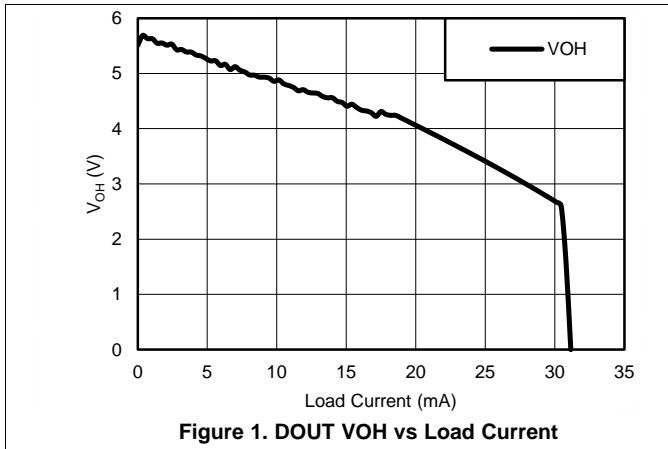

8 Parameter Measurement Information

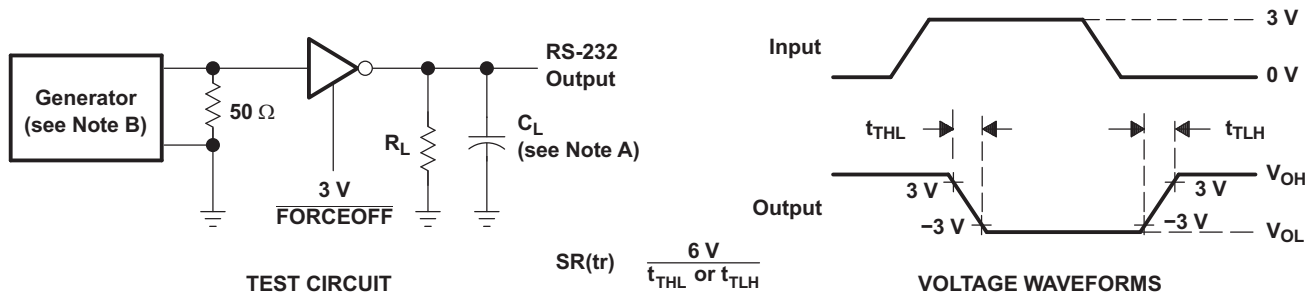

NOTES: A. C_L includes probe and jig capacitance.
 B. The pulse generator has the following characteristics: PRR = 250 kbit/s (MAX3243C/I) and 1 Mbit/s (MAX3243FC/I), $Z_O = 50 \Omega$, 50% duty cycle, $t_r \leq 10$ ns, $t_f \leq 10$ ns.

Figure 3. Driver Slew Rate

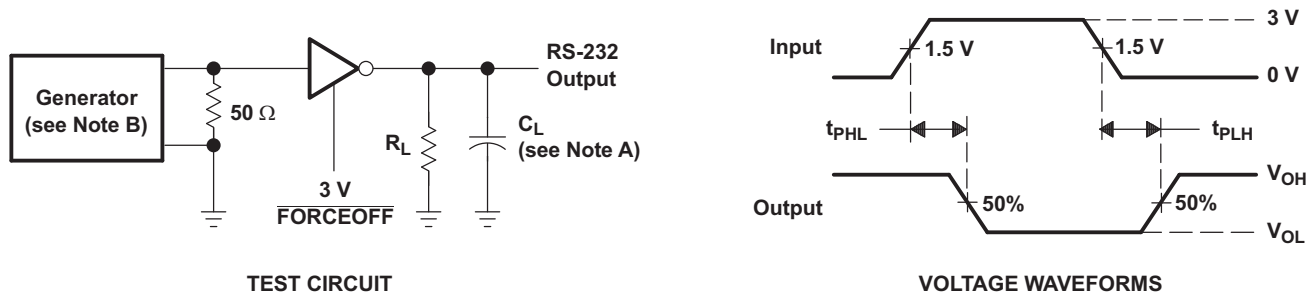

NOTES: A. C_L includes probe and jig capacitance.
 B. The pulse generator has the following characteristics: PRR = 250 kbit/s (MAX3243C/I) and 1 Mbit/s (MAX3243FC/I), $Z_O = 50 \Omega$, 50% duty cycle, $t_r \leq 10$ ns, $t_f \leq 10$ ns.

Figure 4. Driver Pulse Skew

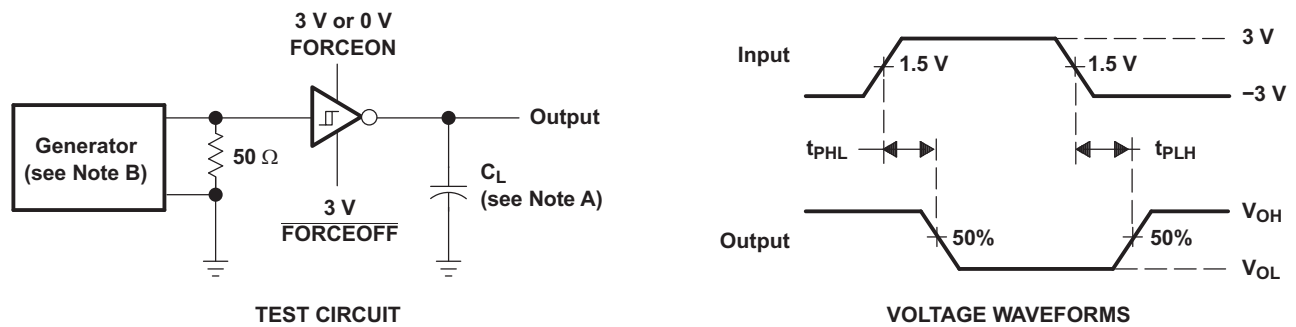

NOTES: A. C_L includes probe and jig capacitance.
 B. The pulse generator has the following characteristics: $Z_O = 50 \Omega$, 50% duty cycle, $t_r \leq 10$ ns, $t_f \leq 10$ ns.

Figure 5. Receiver Propagation Delay Times

Parameter Measurement Information (continued)

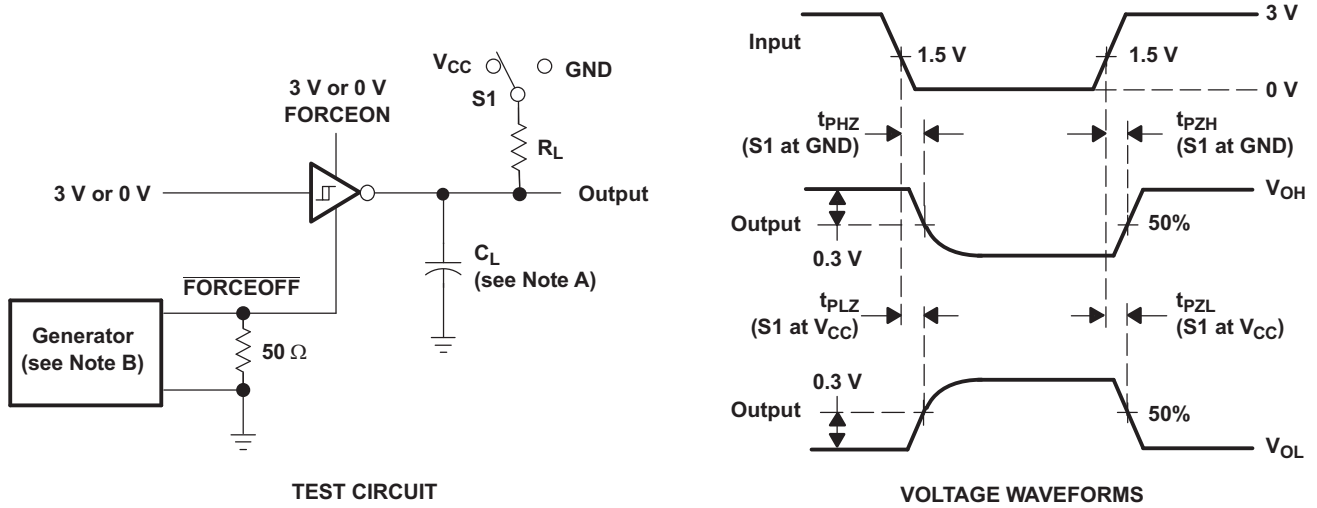

- NOTES: A. C_L includes probe and jig capacitance.
 B. The pulse generator has the following characteristics: $Z_O = 50 \Omega$, 50% duty cycle, $t_r \leq 10 \text{ ns}$, $t_f \leq 10 \text{ ns}$.
 C. t_{PLZ} and t_{PHZ} are the same as t_{dis} .
 D. t_{PZL} and t_{PZH} are the same as t_{en} .

Figure 6. Receiver Enable and Disable Times

Parameter Measurement Information (continued)

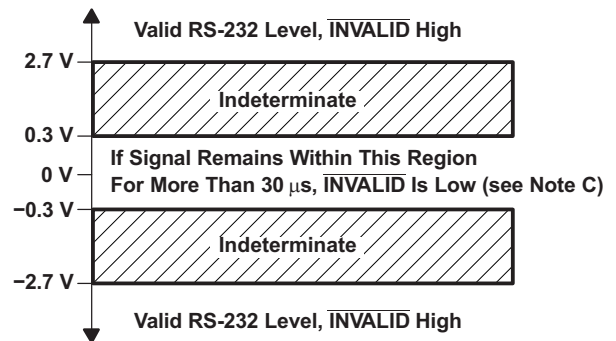
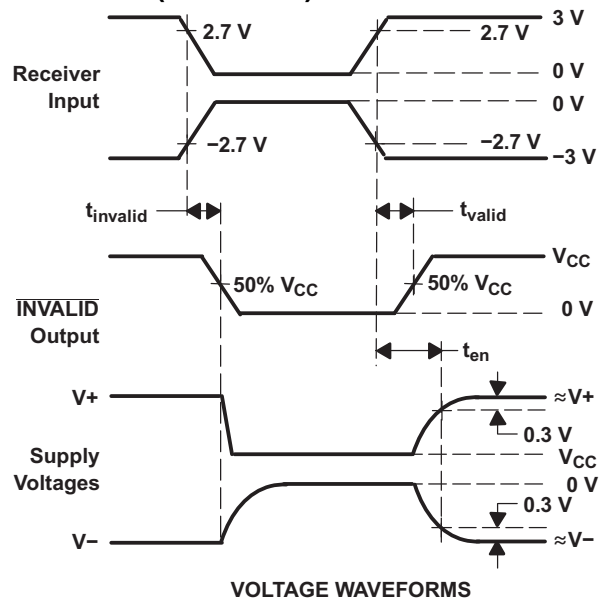
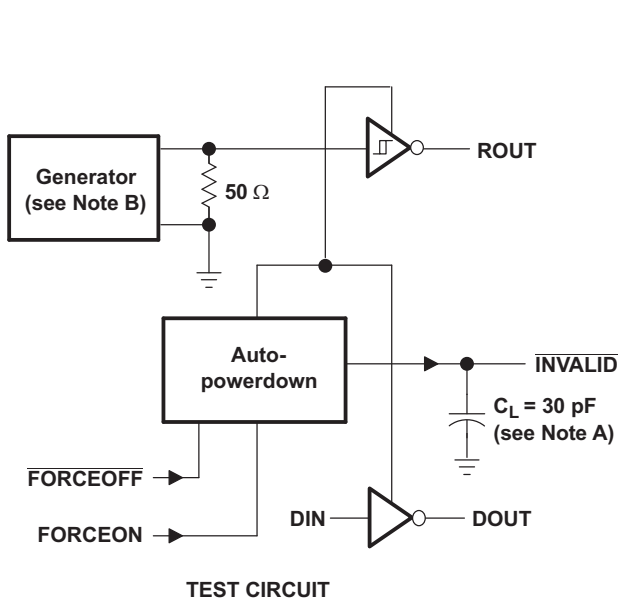

- NOTES: A. C_L includes probe and jig capacitance.
 B. The pulse generator has the following characteristics: PRR = 5 kbit/s, $Z_O = 50 \Omega$, 50% duty cycle, $t_r \leq 10$ ns, $t_f \leq 10$ ns.
 C. Auto-powerdown disables drivers and reduces supply current to $1 \mu A$.

Figure 7. $\overline{INVALID}$ Propagation Delay Times and Supply Enabling Time

9 Detailed Description

9.1 Overview

The MAX3243 device consists of three line drivers, five line receivers, and a dual charge-pump circuit with ± 15 -kV ESD (HBM) protection pin to pin (serial-port connection pins, including GND). The device meets the requirements of TIA/EIA-232-F and provides the electrical interface between an asynchronous communication controller and the serial-port connector. This combination of drivers and receivers matches that needed for the typical serial port used in an IBM PC/AT, or compatible. The charge pump and four small external capacitors allow operation from a single 3-V to 5.5-V supply. In addition, the device includes an always-active noninverting output (ROUT2B), which allows applications using the ring indicator to transmit data while the device is powered down. Flexible control options for power management are available. When the serial port is inactive, the auto-power-down feature functions when FORCEON is low and FORCEOFF is high. During this mode of operation, if the device does not sense a valid RS-232 signal, the driver outputs are disabled. If FORCEOFF is set low, both drivers and receivers (except ROUT2B) are shut off, and the supply current is reduced to 1 μ A. Disconnecting the serial port or turning off the peripheral drivers causes the auto-power-down condition to occur. Auto-power-down can be disabled when FORCEON and FORCEOFF are high and should be done when driving a serial mouse. With auto-power-down enabled, the device is activated automatically when a valid signal is applied to any receiver input. The INVALID output is used to notify the user if an RS-232 signal is present at any receiver input. INVALID is high (valid data) if any receiver input voltage is greater than 2.7 V or less than -2.7 V or has been between -0.3 V and 0.3 V for less than 30 μ s. INVALID is low (invalid data) if all receiver input voltages are between -0.3 V and 0.3 V for more than 30 μ s.

9.2 Functional Block Diagram

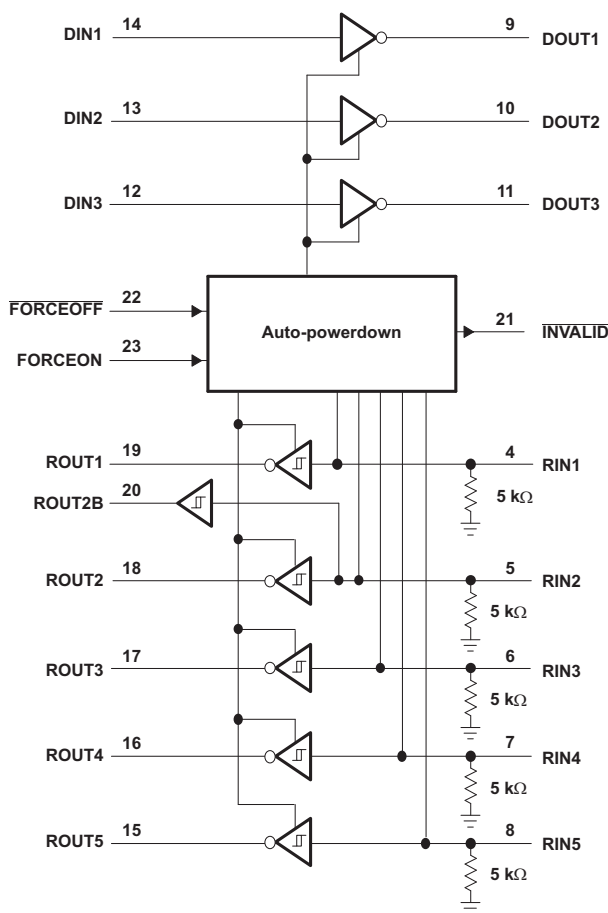

9.3 Feature Description

9.3.1 Auto-Power-Down

Auto-Power-Down can be used to automatically save power when the receivers are unconnected or connected to a powered down remote RS232 port. FORCEON being high will override Auto power down and the drivers will be active. $\overline{\text{FORCEOFF}}$ being low will override FORCEON and will power down all outputs except for ROUT2B and $\overline{\text{INVALID}}$.

9.3.2 Charge Pump

The charge pump increases, inverts, and regulates voltage at V+ and V– pins and requires four external capacitors.

9.3.3 RS232 Driver

Three drivers interface standard logic level to RS232 levels. All DIN inputs must be valid high or low.

9.3.4 RS232 Receiver

Five receivers interface RS232 levels to standard logic levels. An open input will result in a high output on ROUT. Each RIN input includes an internal standard RS232 load.

9.3.5 ROUT2B Receiver

ROUT2B is an always-active noninverting output of RIN2 input, which allows applications using the ring indicator to transmit data while the device is powered down.

9.3.6 Invalid Input Detection

The $\overline{\text{INVALID}}$ output goes active low when all RIN inputs are unpowered. The $\overline{\text{INVALID}}$ output goes inactive high when any RIN input is connected to an active RS232 voltage level.

9.4 Device Functional Modes

Table 1. Each Driver⁽¹⁾

INPUTS				OUTPUT	DRIVER STATUS
DIN	FORCEON	$\overline{\text{FORCEOFF}}$	VALID RIN RS-232 LEVEL	DOUT	
X	X	L	X	Z	Powered off
L	H	H	X	H	Normal operation with auto-powerdown disabled
H	H	H	X	L	
L	L	H	YES	H	Normal operation with auto-powerdown enabled
H	L	H	YES	L	
X	L	H	NO	Z	Power off by auto-powerdown feature

(1) H = high level, L = low level, X = irrelevant, Z = high impedance, YES = any RIN valid, NO = all RIN invalid

Table 2. Each Receiver⁽¹⁾

INPUTS			OUTPUTS	RECEIVER STATUS
RIN	FORCEON	$\overline{\text{FORCEOFF}}$	ROUT	
X	X	L	Z	Powered off
L	X	H	H	Normal operation
H	X	H	L	
Open	X	H	H	

(1) H = high level, L = low level, X = irrelevant, Z = high impedance (off), Open = input disconnected or connected driver off

Table 3. $\overline{\text{INVALID}}$ and ROUT2B Outputs⁽¹⁾

INPUTS				OUTPUTS		OUTPUT STATUS
VALID RIN RS-232 LEVEL	RIN2	FORCEON	$\overline{\text{FORCEOFF}}$	$\overline{\text{INVALID}}$	ROUT2B	
YES	L	X	X	H	L	Always Active
YES	H	X	X	H	H	
YES	OPEN	X	X	H	L	Always Active
NO	OPEN	X	X	L	L	

(1) H = high level, L = low level, X = irrelevant, Z = high impedance (off), OPEN = input disconnected or connected driver off, YES = any RIN valid, NO = all RIN invalid

10 Application and Implementation

NOTE

Information in the following applications sections is not part of the TI component specification, and TI does not warrant its accuracy or completeness. TI's customers are responsible for determining suitability of components for their purposes. Customers should validate and test their design implementation to confirm system functionality.

10.1 Application Information

It is recommended to add capacitors as shown in [Figure 8](#).

10.2 Typical Application

ROUT and DIN connect to UART or general purpose logic lines. RIN and DOUT lines connect to a RS232 connector or cable.

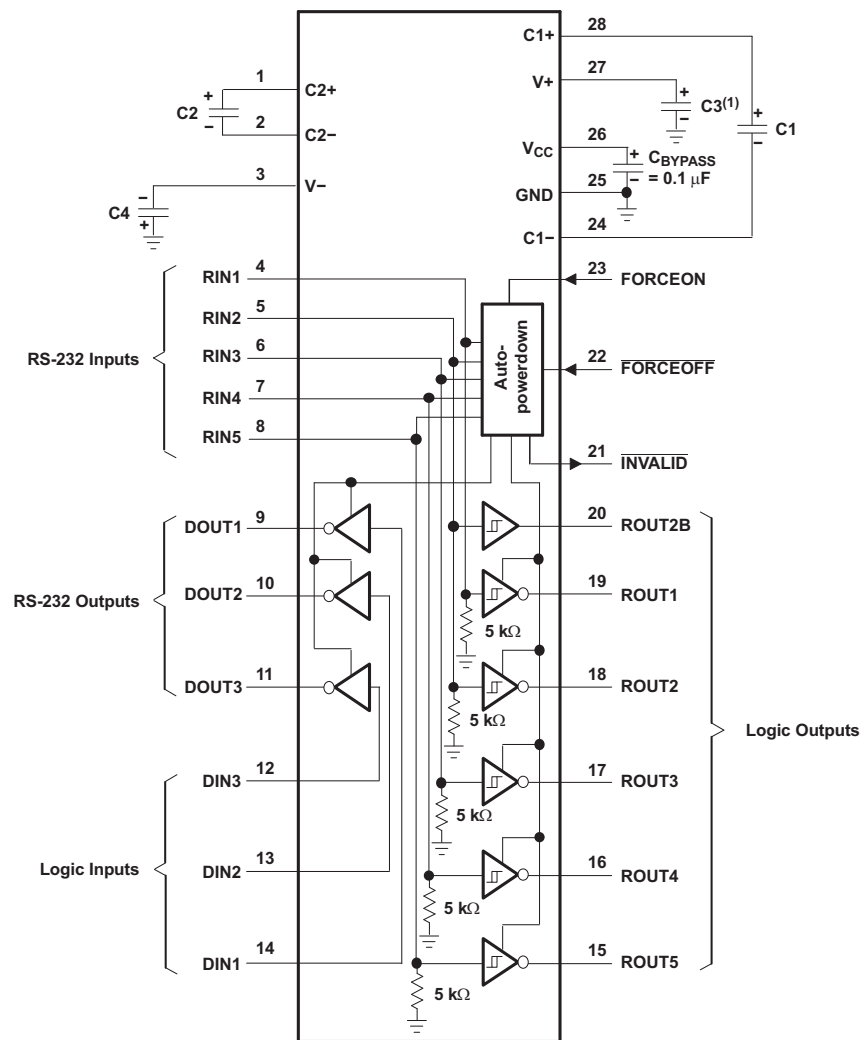

(1) C3 can be connected to V_{CC} or GND.

NOTES: A. Resistor values shown are nominal.

B. Nonpolarized ceramic capacitors are acceptable. If polarized tantalum or electrolytic capacitors are used, they should be connected as shown.

V_{CC} vs CAPACITOR VALUES

V _{CC}	C1	C2, C3, and C4
3.3 V ± 0.3 V	0.1 μF	0.1 μF
5 V ± 0.5 V	0.047 μF	0.33 μF
3 V to 5.5 V	0.1 μF	0.47 μF

Figure 8. Typical Operating Circuit and Capacitor Values

Typical Application (continued)

10.2.1 Design Requirements

- V_{CC} minimum is 3 V and maximum is 5.5V.
- Maximum recommended bit rate is 250 kbit/s.

10.2.2 Detailed Design Procedure

- All DIN, FORCEOFF and FORCEON inputs must be connected to valid low or high logic levels.
- Select capacitor values based on V_{CC} level for best performance.

10.2.3 Application Curves

$V_{CC} = 3.3\text{ V}$

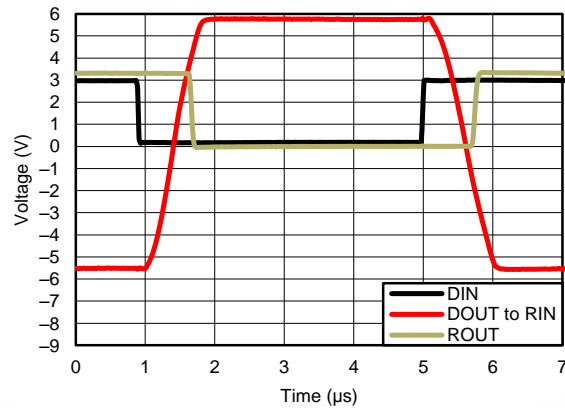

Figure 9. Driver to Receiver Loopback Timing Waveform

11 Power Supply Recommendations

V_{CC} should be between 3 V and 5.5 V. Charge pump capacitors should be chosen using table in [Figure 8](#).

12 Layout

12.1 Layout Guidelines

Keep the external capacitor traces short. This is more important on C1 and C2 nodes that have the fastest rise and fall times.

In the [Layout Example](#) diagram, only critical layout sections are shown. Input and output traces will vary in shape and size depending on the customer application. FORCEON and /FORCEOFF should be pulled up to VCC or GND via a pullup resistor, depending on which configuration the user desires upon power-up.

12.2 Layout Example

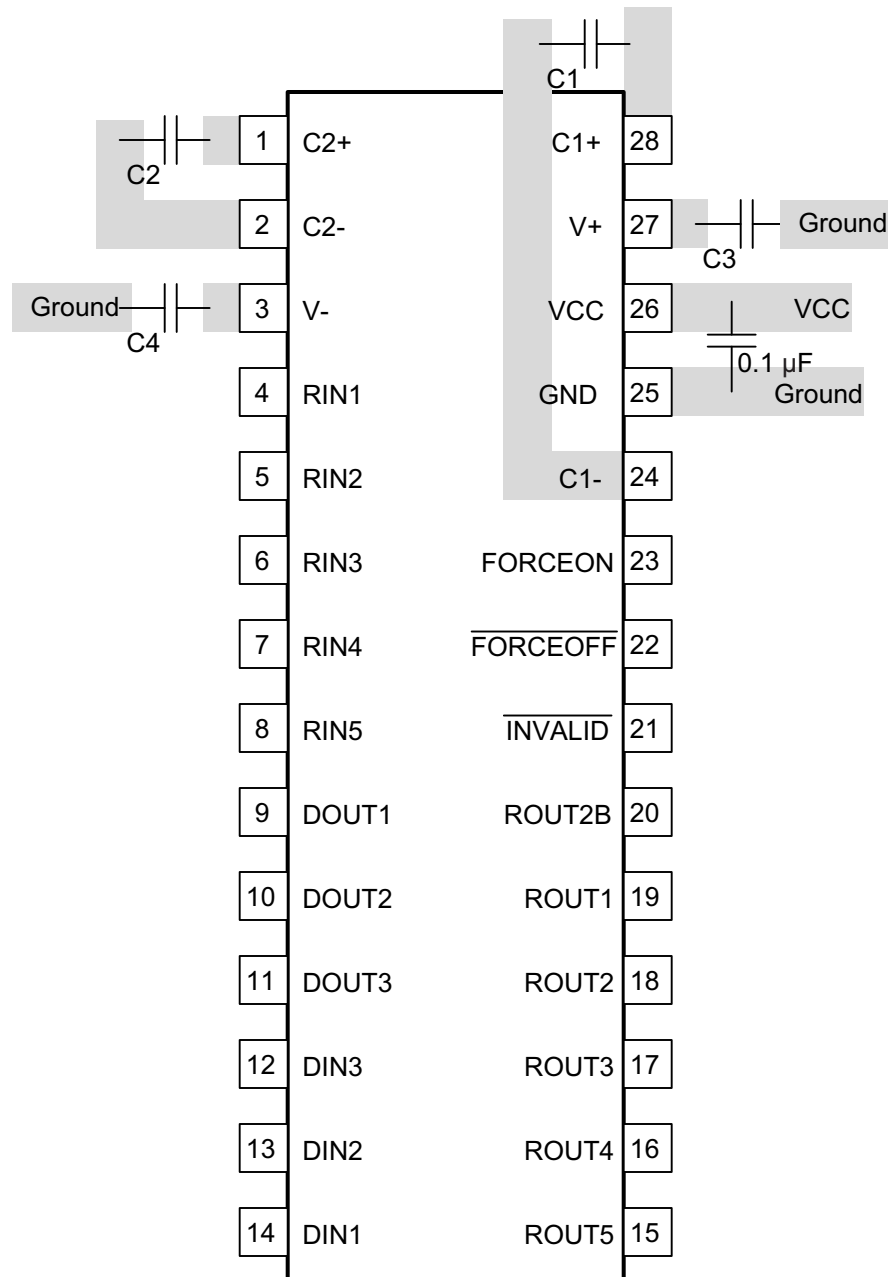

Figure 10. Layout Diagram

13 Device and Documentation Support

13.1 Trademarks

IBM, PC/AT are trademarks of IBM.

All other trademarks are the property of their respective owners.

13.2 Electrostatic Discharge Caution



These devices have limited built-in ESD protection. The leads should be shorted together or the device placed in conductive foam during storage or handling to prevent electrostatic damage to the MOS gates.

13.3 Glossary

[SLYZ022](#) — *TI Glossary*.

This glossary lists and explains terms, acronyms, and definitions.

14 Mechanical, Packaging, and Orderable Information

The following pages include mechanical, packaging, and orderable information. This information is the most current data available for the designated devices. This data is subject to change without notice and revision of this document. For browser-based versions of this data sheet, refer to the left-hand navigation.

PACKAGING INFORMATION

Orderable Device	Status (1)	Package Type	Package Drawing	Pins	Package Qty	Eco Plan (2)	Lead/Ball Finish (6)	MSL Peak Temp (3)	Op Temp (°C)	Device Marking (4/5)	Samples
MAX3243CDB	ACTIVE	SSOP	DB	28	50	Green (RoHS & no Sb/Br)	CU NIPDAU	Level-1-260C-UNLIM	0 to 70	MAX3243C	Samples
MAX3243CDBG4	ACTIVE	SSOP	DB	28	50	Green (RoHS & no Sb/Br)	CU NIPDAU	Level-1-260C-UNLIM	0 to 70	MAX3243C	Samples
MAX3243CDBR	ACTIVE	SSOP	DB	28	2000	Green (RoHS & no Sb/Br)	CU NIPDAU	Level-1-260C-UNLIM	0 to 70	MAX3243C	Samples
MAX3243CDBRE4	ACTIVE	SSOP	DB	28	2000	Green (RoHS & no Sb/Br)	CU NIPDAU	Level-1-260C-UNLIM	0 to 70	MAX3243C	Samples
MAX3243CDBRG4	ACTIVE	SSOP	DB	28	2000	Green (RoHS & no Sb/Br)	CU NIPDAU	Level-1-260C-UNLIM	0 to 70	MAX3243C	Samples
MAX3243CDW	ACTIVE	SOIC	DW	28	20	Green (RoHS & no Sb/Br)	CU NIPDAU	Level-1-260C-UNLIM	0 to 70	MAX3243C	Samples
MAX3243CDWE4	ACTIVE	SOIC	DW	28	20	Green (RoHS & no Sb/Br)	CU NIPDAU	Level-1-260C-UNLIM	0 to 70	MAX3243C	Samples
MAX3243CDWG4	ACTIVE	SOIC	DW	28	20	Green (RoHS & no Sb/Br)	CU NIPDAU	Level-1-260C-UNLIM	0 to 70	MAX3243C	Samples
MAX3243CDWR	ACTIVE	SOIC	DW	28	1000	Green (RoHS & no Sb/Br)	CU NIPDAU	Level-1-260C-UNLIM	0 to 70	MAX3243C	Samples
MAX3243CDWRG4	ACTIVE	SOIC	DW	28	1000	Green (RoHS & no Sb/Br)	CU NIPDAU	Level-1-260C-UNLIM	0 to 70	MAX3243C	Samples
MAX3243CPW	ACTIVE	TSSOP	PW	28	50	Green (RoHS & no Sb/Br)	CU NIPDAU	Level-1-260C-UNLIM	0 to 70	MA3243C	Samples
MAX3243CPWE4	ACTIVE	TSSOP	PW	28	50	Green (RoHS & no Sb/Br)	CU NIPDAU	Level-1-260C-UNLIM	0 to 70	MA3243C	Samples
MAX3243CPWG4	ACTIVE	TSSOP	PW	28	50	Green (RoHS & no Sb/Br)	CU NIPDAU	Level-1-260C-UNLIM	0 to 70	MA3243C	Samples
MAX3243CPWR	ACTIVE	TSSOP	PW	28	2000	Green (RoHS & no Sb/Br)	CU NIPDAU	Level-1-260C-UNLIM	0 to 70	MA3243C	Samples
MAX3243CPWRE4	ACTIVE	TSSOP	PW	28	2000	Green (RoHS & no Sb/Br)	CU NIPDAU	Level-1-260C-UNLIM	0 to 70	MA3243C	Samples
MAX3243CPWRG4	ACTIVE	TSSOP	PW	28	2000	Green (RoHS & no Sb/Br)	CU NIPDAU	Level-1-260C-UNLIM	0 to 70	MA3243C	Samples
MAX3243IDB	ACTIVE	SSOP	DB	28	50	Green (RoHS & no Sb/Br)	CU NIPDAU	Level-1-260C-UNLIM	-40 to 85	MAX3243I	Samples

Orderable Device	Status (1)	Package Type	Package Drawing	Pins	Package Qty	Eco Plan (2)	Lead/Ball Finish (6)	MSL Peak Temp (3)	Op Temp (°C)	Device Marking (4/5)	Samples
MAX3243IDBG4	ACTIVE	SSOP	DB	28	50	Green (RoHS & no Sb/Br)	CU NIPDAU	Level-1-260C-UNLIM	-40 to 85	MAX3243I	Samples
MAX3243IDBR	ACTIVE	SSOP	DB	28	2000	Green (RoHS & no Sb/Br)	CU NIPDAU	Level-1-260C-UNLIM	-40 to 85	MAX3243I	Samples
MAX3243IDBRE4	ACTIVE	SSOP	DB	28	2000	Green (RoHS & no Sb/Br)	CU NIPDAU	Level-1-260C-UNLIM	-40 to 85	MAX3243I	Samples
MAX3243IDBRG4	ACTIVE	SSOP	DB	28	2000	Green (RoHS & no Sb/Br)	CU NIPDAU	Level-1-260C-UNLIM	-40 to 85	MAX3243I	Samples
MAX3243IDW	ACTIVE	SOIC	DW	28	20	Green (RoHS & no Sb/Br)	CU NIPDAU	Level-1-260C-UNLIM	-40 to 85	MAX3243I	Samples
MAX3243IDWG4	ACTIVE	SOIC	DW	28	20	Green (RoHS & no Sb/Br)	CU NIPDAU	Level-1-260C-UNLIM	-40 to 85	MAX3243I	Samples
MAX3243IDWR	ACTIVE	SOIC	DW	28	1000	Green (RoHS & no Sb/Br)	CU NIPDAU CU SN	Level-1-260C-UNLIM	-40 to 85	MAX3243I	Samples
MAX3243IDWRE4	ACTIVE	SOIC	DW	28	1000	Green (RoHS & no Sb/Br)	CU NIPDAU	Level-1-260C-UNLIM	-40 to 85	MAX3243I	Samples
MAX3243IDWRG4	ACTIVE	SOIC	DW	28	1000	Green (RoHS & no Sb/Br)	CU NIPDAU	Level-1-260C-UNLIM	-40 to 85	MAX3243I	Samples
MAX3243IPW	ACTIVE	TSSOP	PW	28	50	Green (RoHS & no Sb/Br)	CU NIPDAU	Level-1-260C-UNLIM	-40 to 85	MB3243I	Samples
MAX3243IPWG4	ACTIVE	TSSOP	PW	28		TBD	Call TI	Call TI	-40 to 85		Samples
MAX3243IPWR	ACTIVE	TSSOP	PW	28	2000	Green (RoHS & no Sb/Br)	CU NIPDAU	Level-1-260C-UNLIM	-40 to 85	MB3243I	Samples
MAX3243IPWRE4	ACTIVE	TSSOP	PW	28	2000	Green (RoHS & no Sb/Br)	CU NIPDAU	Level-1-260C-UNLIM	-40 to 85	MB3243I	Samples
MAX3243IPWRG4	ACTIVE	TSSOP	PW	28	2000	Green (RoHS & no Sb/Br)	CU NIPDAU	Level-1-260C-UNLIM	-40 to 85	MB3243I	Samples

(1) The marketing status values are defined as follows:

ACTIVE: Product device recommended for new designs.

LIFEBUY: TI has announced that the device will be discontinued, and a lifetime-buy period is in effect.

NRND: Not recommended for new designs. Device is in production to support existing customers, but TI does not recommend using this part in a new design.

PREVIEW: Device has been announced but is not in production. Samples may or may not be available.

OBSOLETE: TI has discontinued the production of the device.

(2) Eco Plan - The planned eco-friendly classification: Pb-Free (RoHS), Pb-Free (RoHS Exempt), or Green (RoHS & no Sb/Br) - please check <http://www.ti.com/productcontent> for the latest availability information and additional product content details.

TBD: The Pb-Free/Green conversion plan has not been defined.

Pb-Free (RoHS): TI's terms "Lead-Free" or "Pb-Free" mean semiconductor products that are compatible with the current RoHS requirements for all 6 substances, including the requirement that lead not exceed 0.1% by weight in homogeneous materials. Where designed to be soldered at high temperatures, TI Pb-Free products are suitable for use in specified lead-free processes.

Pb-Free (RoHS Exempt): This component has a RoHS exemption for either 1) lead-based flip-chip solder bumps used between the die and package, or 2) lead-based die adhesive used between the die and leadframe. The component is otherwise considered Pb-Free (RoHS compatible) as defined above.

Green (RoHS & no Sb/Br): TI defines "Green" to mean Pb-Free (RoHS compatible), and free of Bromine (Br) and Antimony (Sb) based flame retardants (Br or Sb do not exceed 0.1% by weight in homogeneous material)

(3) MSL, Peak Temp. - The Moisture Sensitivity Level rating according to the JEDEC industry standard classifications, and peak solder temperature.

(4) There may be additional marking, which relates to the logo, the lot trace code information, or the environmental category on the device.

(5) Multiple Device Markings will be inside parentheses. Only one Device Marking contained in parentheses and separated by a "~" will appear on a device. If a line is indented then it is a continuation of the previous line and the two combined represent the entire Device Marking for that device.

(6) Lead/Ball Finish - Orderable Devices may have multiple material finish options. Finish options are separated by a vertical ruled line. Lead/Ball Finish values may wrap to two lines if the finish value exceeds the maximum column width.

Important Information and Disclaimer: The information provided on this page represents TI's knowledge and belief as of the date that it is provided. TI bases its knowledge and belief on information provided by third parties, and makes no representation or warranty as to the accuracy of such information. Efforts are underway to better integrate information from third parties. TI has taken and continues to take reasonable steps to provide representative and accurate information but may not have conducted destructive testing or chemical analysis on incoming materials and chemicals. TI and TI suppliers consider certain information to be proprietary, and thus CAS numbers and other limited information may not be available for release.

In no event shall TI's liability arising out of such information exceed the total purchase price of the TI part(s) at issue in this document sold by TI to Customer on an annual basis.

OTHER QUALIFIED VERSIONS OF MAX3243 :

- Enhanced Product: [MAX3243-EP](#)

NOTE: Qualified Version Definitions:

- Enhanced Product - Supports Defense, Aerospace and Medical Applications

TAPE AND REEL INFORMATION

QUADRANT ASSIGNMENTS FOR PIN 1 ORIENTATION IN TAPE

*All dimensions are nominal

Device	Package Type	Package Drawing	Pins	SPQ	Reel Diameter (mm)	Reel Width W1 (mm)	A0 (mm)	B0 (mm)	K0 (mm)	P1 (mm)	W (mm)	Pin1 Quadrant
MAX3243CDBR	SSOP	DB	28	2000	330.0	16.4	8.2	10.5	2.5	12.0	16.0	Q1
MAX3243CDWR	SOIC	DW	28	1000	330.0	32.4	11.35	18.67	3.1	16.0	32.0	Q1
MAX3243CPWR	TSSOP	PW	28	2000	330.0	16.4	6.9	10.2	1.8	12.0	16.0	Q1
MAX3243IDBR	SSOP	DB	28	2000	330.0	16.4	8.2	10.5	2.5	12.0	16.0	Q1
MAX3243IDWR	SOIC	DW	28	1000	330.0	32.4	11.35	18.67	3.1	16.0	32.0	Q1
MAX3243IDWRG4	SOIC	DW	28	1000	330.0	32.4	11.35	18.67	3.1	16.0	32.0	Q1
MAX3243IPWR	TSSOP	PW	28	2000	330.0	16.4	6.9	10.2	1.8	12.0	16.0	Q1
MAX3243IPWR	TSSOP	PW	28	2000	330.0	16.4	6.9	10.2	1.8	12.0	16.0	Q1

TAPE AND REEL BOX DIMENSIONS

*All dimensions are nominal

Device	Package Type	Package Drawing	Pins	SPQ	Length (mm)	Width (mm)	Height (mm)
MAX3243CDBR	SSOP	DB	28	2000	367.0	367.0	38.0
MAX3243CDWR	SOIC	DW	28	1000	367.0	367.0	55.0
MAX3243CPWR	TSSOP	PW	28	2000	367.0	367.0	38.0
MAX3243IDBR	SSOP	DB	28	2000	367.0	367.0	38.0
MAX3243IDWR	SOIC	DW	28	1000	367.0	367.0	55.0
MAX3243IDWRG4	SOIC	DW	28	1000	367.0	367.0	55.0
MAX3243IPWR	TSSOP	PW	28	2000	367.0	367.0	38.0
MAX3243IPWR	TSSOP	PW	28	2000	367.0	367.0	38.0

DW (R-PDSO-G28)

PLASTIC SMALL OUTLINE

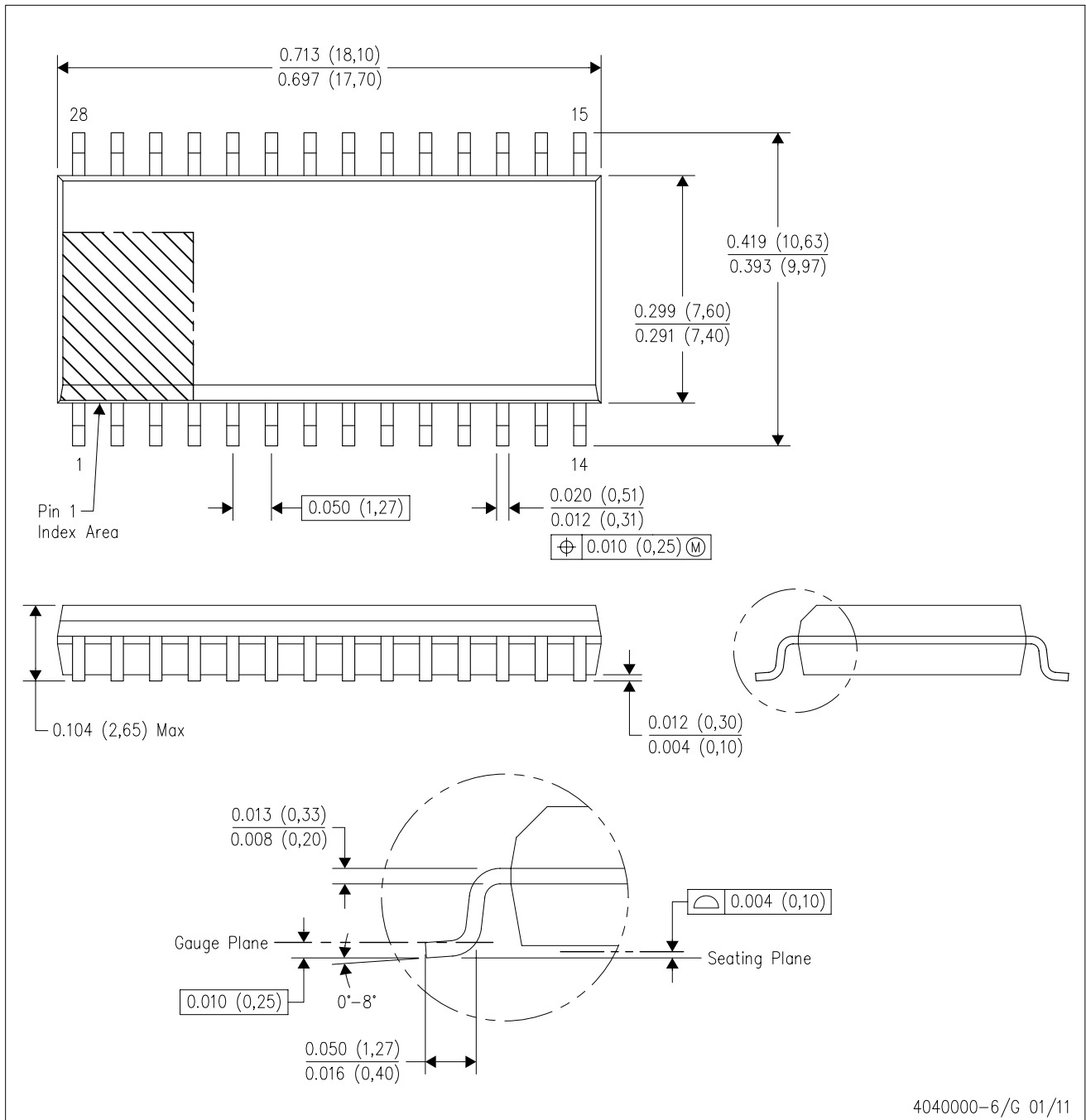

4040000-6/G 01/11

- NOTES:
- A. All linear dimensions are in inches (millimeters). Dimensioning and tolerancing per ASME Y14.5M-1994.
 - B. This drawing is subject to change without notice.
 - C. Body dimensions do not include mold flash or protrusion not to exceed 0.006 (0,15).
 - D. Falls within JEDEC MS-013 variation AE.

DW (R-PDSO-G28)

PLASTIC SMALL OUTLINE

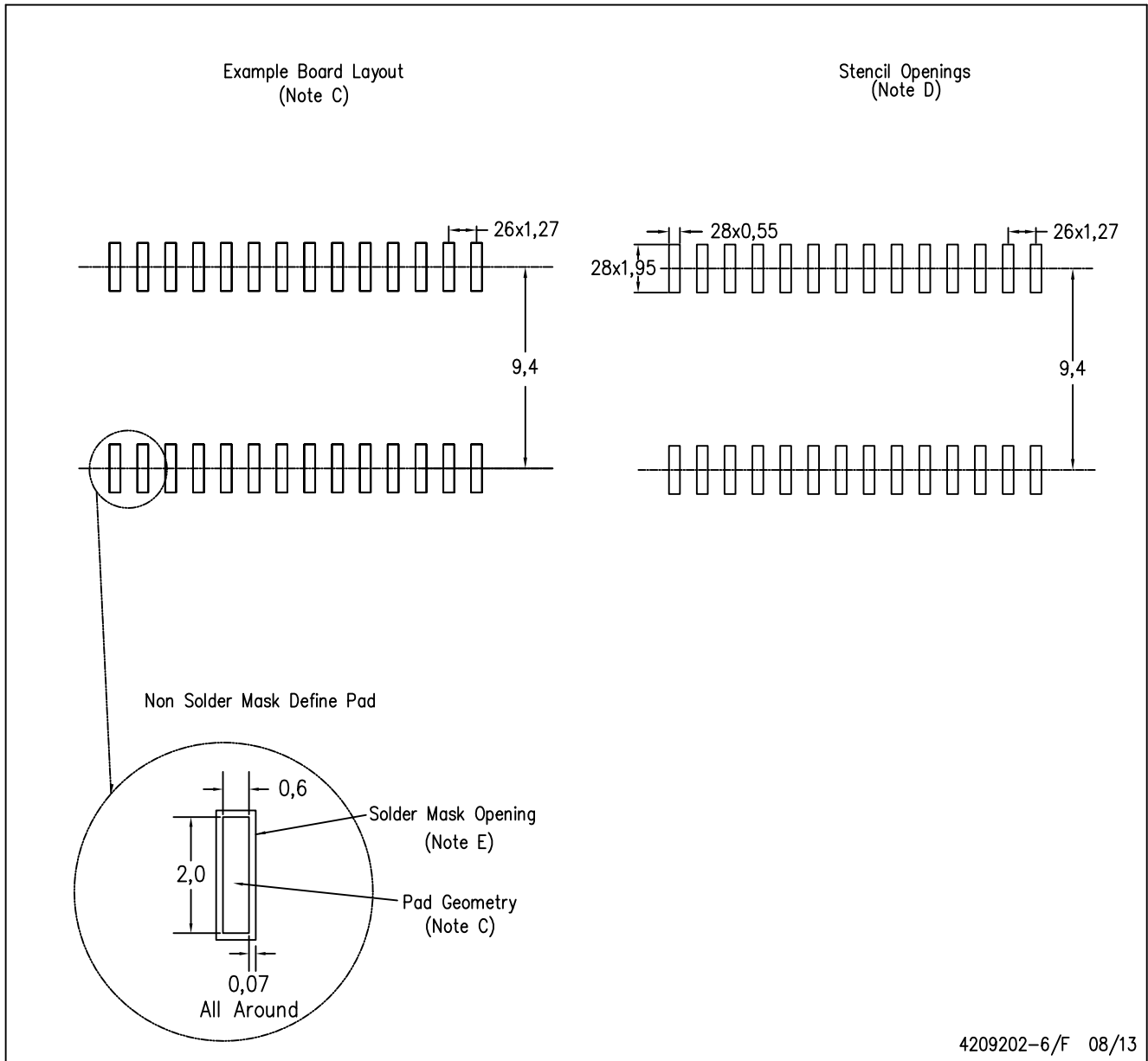

- NOTES:
- A. All linear dimensions are in millimeters.
 - B. This drawing is subject to change without notice.
 - C. Refer to IPC7351 for alternate board design.
 - D. Laser cutting apertures with trapezoidal walls and also rounding corners will offer better paste release. Customers should contact their board assembly site for stencil design recommendations. Refer to IPC-7525
 - E. Customers should contact their board fabrication site for solder mask tolerances between and around signal pads.

MECHANICAL DATA

PW (R-PDSO-G28)

PLASTIC SMALL OUTLINE

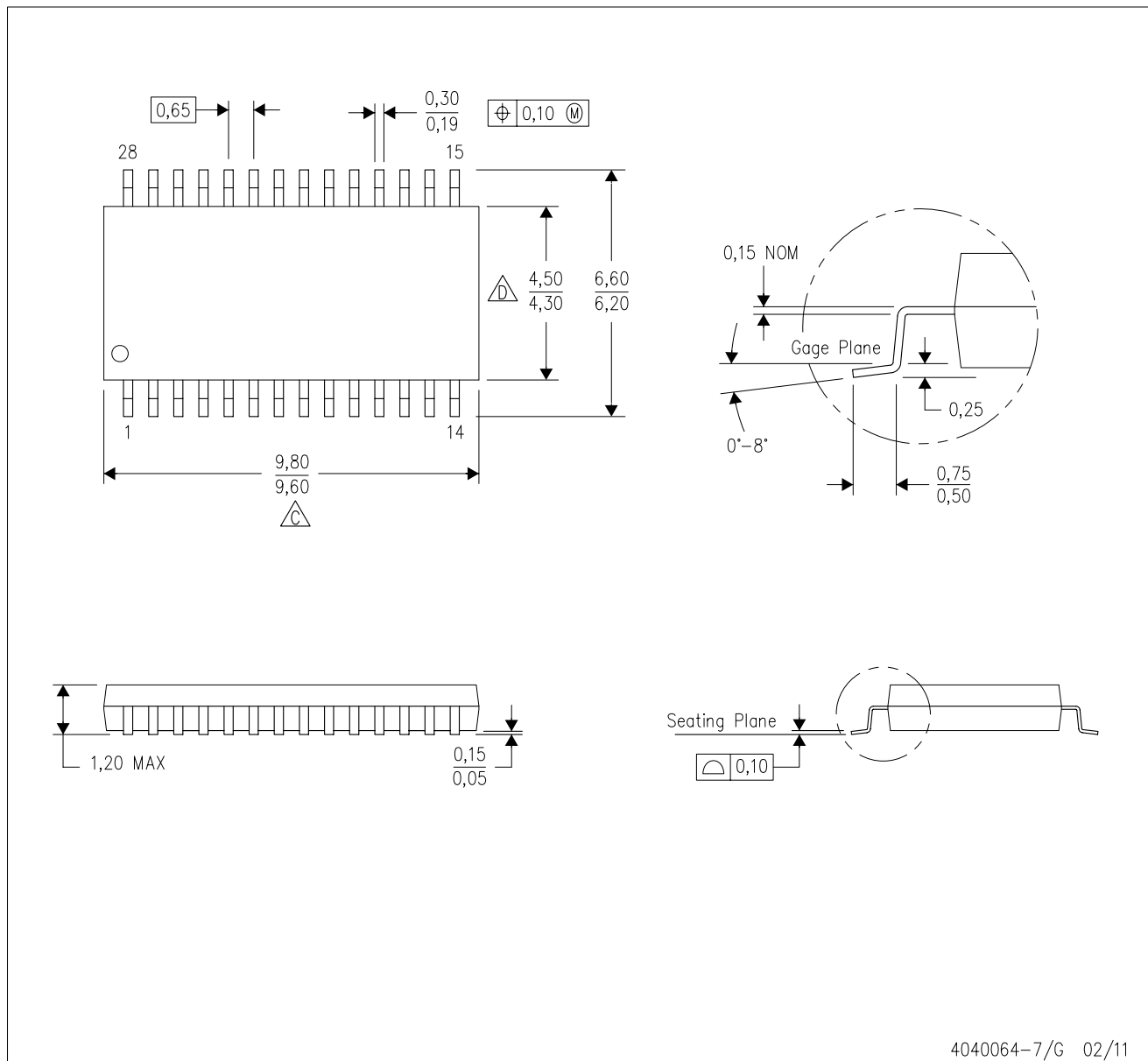

4040064-7/G 02/11

- NOTES:
- A. All linear dimensions are in millimeters. Dimensioning and tolerancing per ASME Y14.5M-1994.
 - B. This drawing is subject to change without notice.
 - C. Body length does not include mold flash, protrusions, or gate burrs. Mold flash, protrusions, or gate burrs shall not exceed 0,15 each side.
 - D. Body width does not include interlead flash. Interlead flash shall not exceed 0,25 each side.
 - E. Falls within JEDEC MO-153

PW (R-PDSO-G28)

PLASTIC SMALL OUTLINE

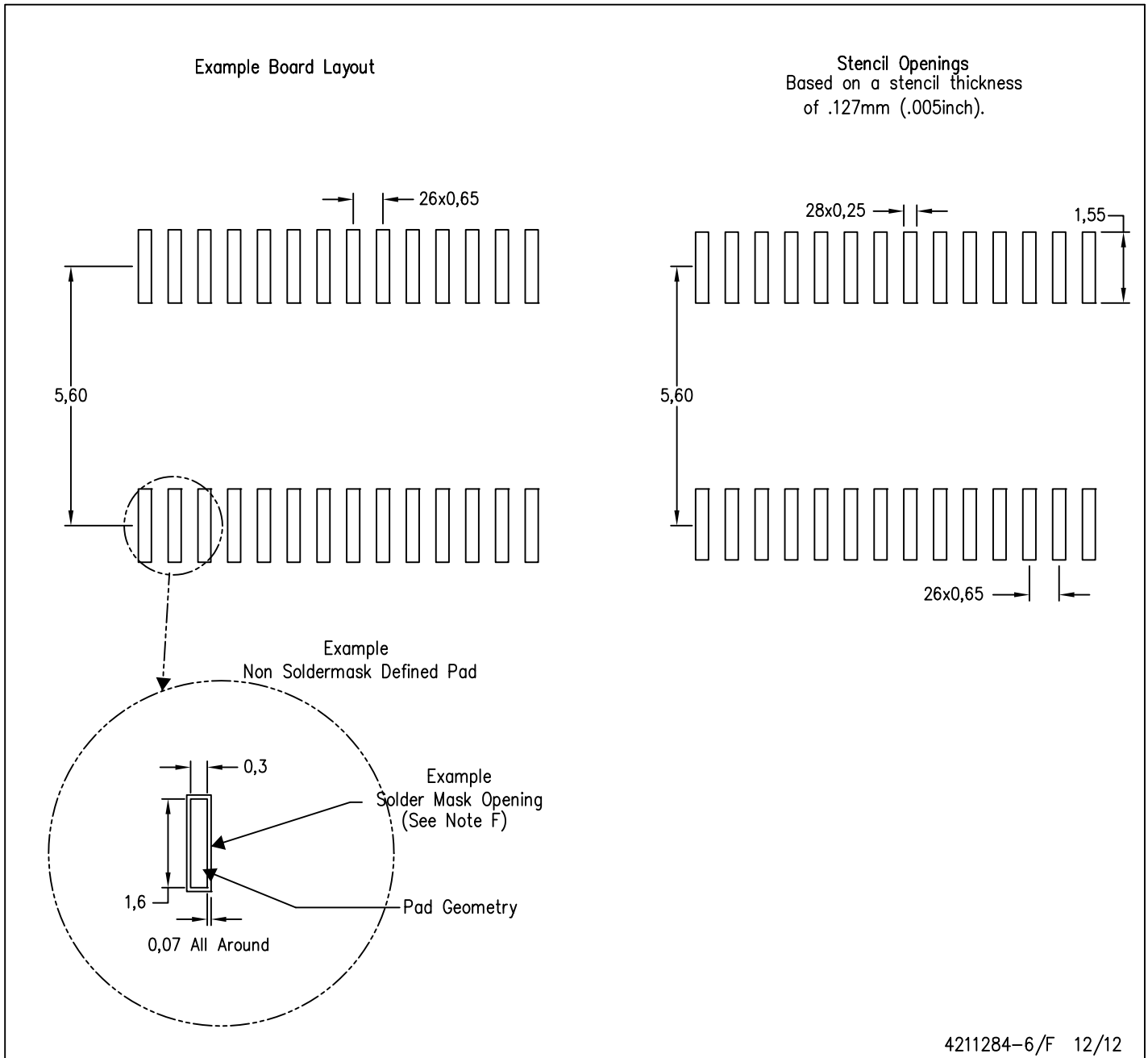

- NOTES:
- A. All linear dimensions are in millimeters.
 - B. This drawing is subject to change without notice.
 - C. Publication IPC-7351 is recommended for alternate design.
 - D. Laser cutting apertures with trapezoidal walls and also rounding corners will offer better paste release. Customers should contact their board assembly site for stencil design recommendations. Refer to IPC-7525 for other stencil recommendations.
 - E. Customers should contact their board fabrication site for solder mask tolerances between and around signal pads.

PW (R-PDSO-G28)

PLASTIC SMALL OUTLINE

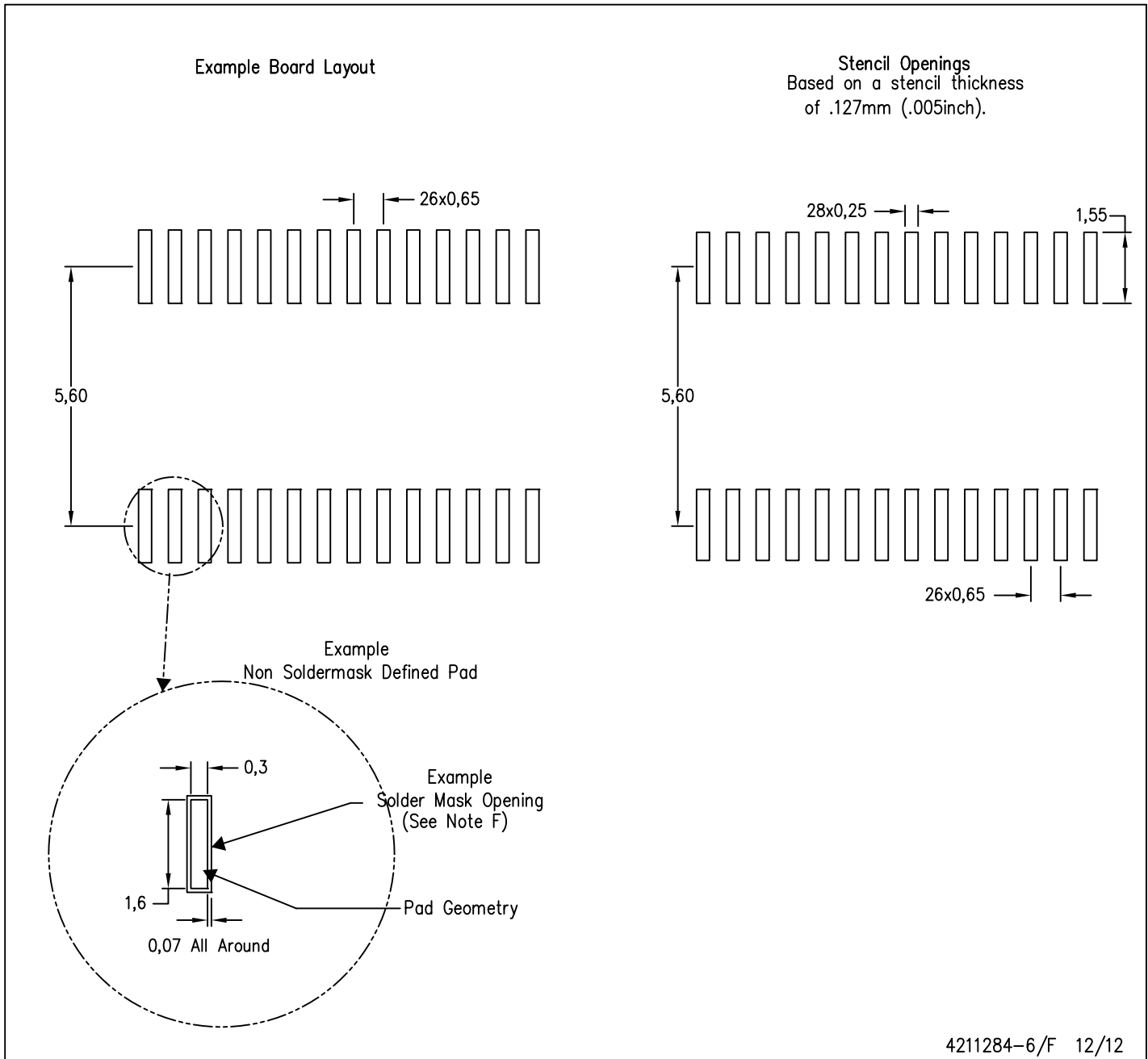

- NOTES:
- A. All linear dimensions are in millimeters.
 - B. This drawing is subject to change without notice.
 - C. Publication IPC-7351 is recommended for alternate design.
 - D. Laser cutting apertures with trapezoidal walls and also rounding corners will offer better paste release. Customers should contact their board assembly site for stencil design recommendations. Refer to IPC-7525 for other stencil recommendations.
 - E. Customers should contact their board fabrication site for solder mask tolerances between and around signal pads.

DB (R-PDSO-G**)

PLASTIC SMALL-OUTLINE

28 PINS SHOWN



- NOTES: A. All linear dimensions are in millimeters.
 B. This drawing is subject to change without notice.
 C. Body dimensions do not include mold flash or protrusion not to exceed 0,15.
 D. Falls within JEDEC MO-150

IMPORTANT NOTICE

Texas Instruments Incorporated and its subsidiaries (TI) reserve the right to make corrections, enhancements, improvements and other changes to its semiconductor products and services per JESD46, latest issue, and to discontinue any product or service per JESD48, latest issue. Buyers should obtain the latest relevant information before placing orders and should verify that such information is current and complete. All semiconductor products (also referred to herein as "components") are sold subject to TI's terms and conditions of sale supplied at the time of order acknowledgment.

TI warrants performance of its components to the specifications applicable at the time of sale, in accordance with the warranty in TI's terms and conditions of sale of semiconductor products. Testing and other quality control techniques are used to the extent TI deems necessary to support this warranty. Except where mandated by applicable law, testing of all parameters of each component is not necessarily performed.

TI assumes no liability for applications assistance or the design of Buyers' products. Buyers are responsible for their products and applications using TI components. To minimize the risks associated with Buyers' products and applications, Buyers should provide adequate design and operating safeguards.

TI does not warrant or represent that any license, either express or implied, is granted under any patent right, copyright, mask work right, or other intellectual property right relating to any combination, machine, or process in which TI components or services are used. Information published by TI regarding third-party products or services does not constitute a license to use such products or services or a warranty or endorsement thereof. Use of such information may require a license from a third party under the patents or other intellectual property of the third party, or a license from TI under the patents or other intellectual property of TI.

Reproduction of significant portions of TI information in TI data books or data sheets is permissible only if reproduction is without alteration and is accompanied by all associated warranties, conditions, limitations, and notices. TI is not responsible or liable for such altered documentation. Information of third parties may be subject to additional restrictions.

Resale of TI components or services with statements different from or beyond the parameters stated by TI for that component or service voids all express and any implied warranties for the associated TI component or service and is an unfair and deceptive business practice. TI is not responsible or liable for any such statements.

Buyer acknowledges and agrees that it is solely responsible for compliance with all legal, regulatory and safety-related requirements concerning its products, and any use of TI components in its applications, notwithstanding any applications-related information or support that may be provided by TI. Buyer represents and agrees that it has all the necessary expertise to create and implement safeguards which anticipate dangerous consequences of failures, monitor failures and their consequences, lessen the likelihood of failures that might cause harm and take appropriate remedial actions. Buyer will fully indemnify TI and its representatives against any damages arising out of the use of any TI components in safety-critical applications.

In some cases, TI components may be promoted specifically to facilitate safety-related applications. With such components, TI's goal is to help enable customers to design and create their own end-product solutions that meet applicable functional safety standards and requirements. Nonetheless, such components are subject to these terms.

No TI components are authorized for use in FDA Class III (or similar life-critical medical equipment) unless authorized officers of the parties have executed a special agreement specifically governing such use.

Only those TI components which TI has specifically designated as military grade or "enhanced plastic" are designed and intended for use in military/aerospace applications or environments. Buyer acknowledges and agrees that any military or aerospace use of TI components which have **not** been so designated is solely at the Buyer's risk, and that Buyer is solely responsible for compliance with all legal and regulatory requirements in connection with such use.

TI has specifically designated certain components as meeting ISO/TS16949 requirements, mainly for automotive use. In any case of use of non-designated products, TI will not be responsible for any failure to meet ISO/TS16949.

Products

Audio	www.ti.com/audio
Amplifiers	amplifier.ti.com
Data Converters	dataconverter.ti.com
DLP® Products	www.dlp.com
DSP	dsp.ti.com
Clocks and Timers	www.ti.com/clocks
Interface	interface.ti.com
Logic	logic.ti.com
Power Mgmt	power.ti.com
Microcontrollers	microcontroller.ti.com
RFID	www.ti-rfid.com
OMAP Applications Processors	www.ti.com/omap
Wireless Connectivity	www.ti.com/wirelessconnectivity

Applications

Automotive and Transportation	www.ti.com/automotive
Communications and Telecom	www.ti.com/communications
Computers and Peripherals	www.ti.com/computers
Consumer Electronics	www.ti.com/consumer-apps
Energy and Lighting	www.ti.com/energy
Industrial	www.ti.com/industrial
Medical	www.ti.com/medical
Security	www.ti.com/security
Space, Avionics and Defense	www.ti.com/space-avionics-defense
Video and Imaging	www.ti.com/video

TI E2E Community

e2e.ti.com

AMEYA360

Components Supply Platform

Authorized Distribution Brand :



Website :

Welcome to visit www.ameya360.com

Contact Us :

➤ Address :

401 Building No.5, JiuGe Business Center, Lane 2301, Yishan Rd
Minhang District, Shanghai , China

➤ Sales :

Direct +86 (21) 6401-6692

Email amall@ameya360.com

QQ 800077892

Skype [ameyasales1](#) [ameyasales2](#)

➤ Customer Service :

Email service@ameya360.com

➤ Partnership :

Tel +86 (21) 64016692-8333

Email mkt@ameya360.com