



The Future of Analog IC Technology™

MP1580

2A, 380 KHz

Step-Down Converter

DESCRIPTION

The MP1580 is a monolithic step-down switch mode converter with a built in internal power MOSFET. It achieves 2A continuous output current over a wide input supply range with excellent load and line regulation.

Current mode operation provides fast transient response and eases loop stabilization.

Fault condition protection includes cycle-by-cycle current limiting and thermal shutdown. In shutdown mode the regulator draws 23µA of supply current.

The MP1580 requires a minimum number of readily available standard external components. A synchronization pin allows the part to be driven to 600KHz.

EVALUATION BOARD REFERENCE

Board Number	Dimensions
EV0007	2.3"X x 1.5"Y x 0.5"Z

FEATURES

- 2A Output Current
- 0.18Ω Internal Power MOSFET Switch
- Stable with Low ESR Output Ceramic Capacitors
- Up to 95% Efficiency
- 23µA Shutdown Mode
- Fixed 380KHz Frequency
- Thermal Shutdown
- Cycle-by-Cycle Over Current Protection
- Wide 4.75 to 25V Operating Input Range
- Output Adjustable from 1.22V to 21V
- Programmable Under Voltage Lockout
- Frequency Synchronization Input
- Available in an 8-Pin SO Package

APPLICATIONS

- Distributed Power Systems
- Battery Chargers
- Pre-Regulator for Linear Regulators

"MPS" and "The Future of Analog IC Technology" are Trademarks of Monolithic Power Systems, Inc.

TYPICAL APPLICATION

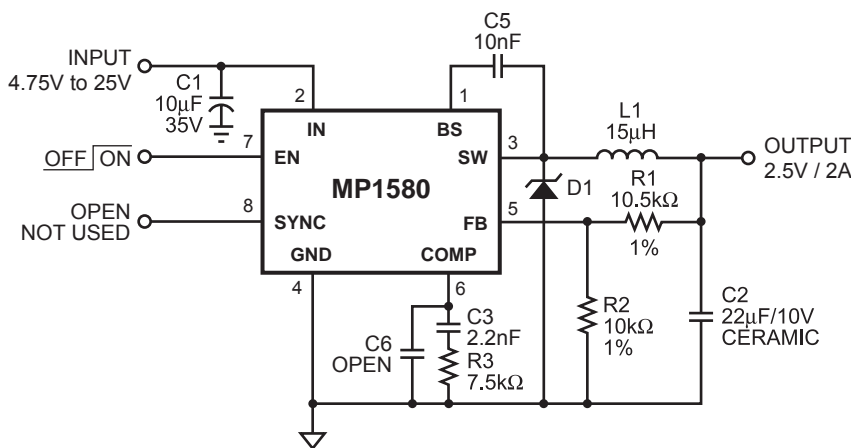

Efficiency vs Output Current Voltage

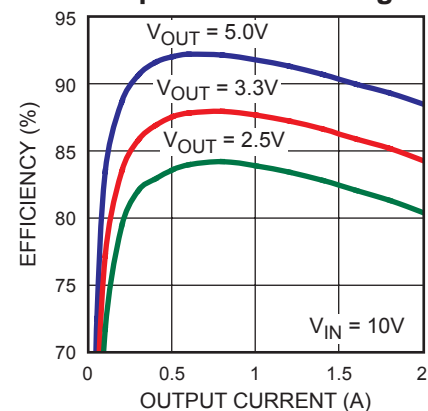

PACKAGE REFERENCE

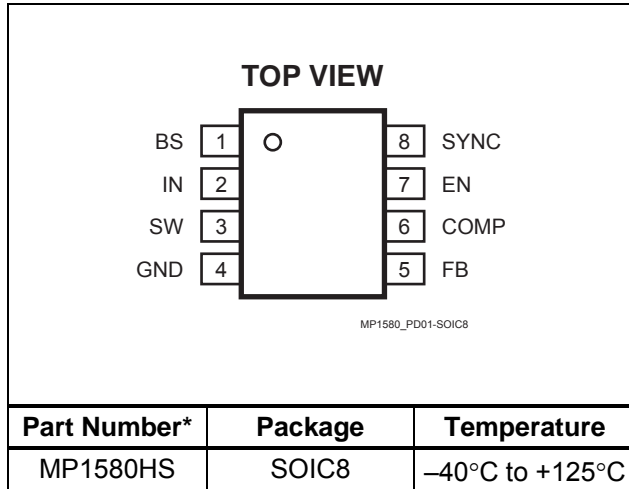

* For Tape & Reel, add suffix -Z (eg. MP1580HS-Z)
For Lead Free, add suffix -LF (eg. MP1580HS -LF-Z)

ABSOLUTE MAXIMUM RATINGS ⁽¹⁾

Supply Voltage (V_{IN})	27V
Switch Voltage (V_{SW})	-1V to $V_{IN} + 1V$
Bootstrap Voltage (V_{BS})	$V_{SW} + 6V$
Feedback Voltage (V_{FB})	-0.3V to +6V
Enable/UVLO Voltage (V_{EN})	-0.3V to +6V
Comp Voltage (V_{COMP})	-0.3V to +6V
Sync Voltage (V_{SYNC})	-0.3V to +6V
Junction Temperature	+150°C
Lead Temperature	+260°C
Storage Temperature	-65°C to +150°C

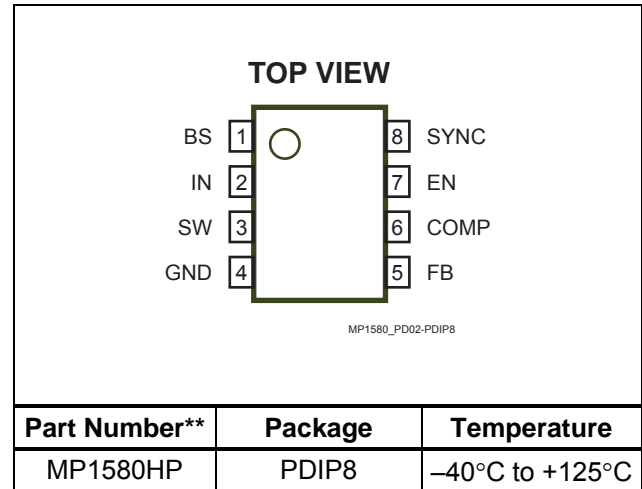

** For Tape & Reel, add suffix -Z (eg. MP1580HP-Z)
For Lead Free, add suffix -LF (eg. MP1580HP -LF-Z)

Recommended Operating Conditions ⁽²⁾
 Input Voltage (V_{IN}) 4.75V to 25V
 Operating Temperature..... -40°C to +125°C

Thermal Resistance ⁽³⁾	θ_{JA}	θ_{JC}	
SOIC8	105	50	°C/W
PDIP8	95	55	°C/W

Notes:

- Exceeding these ratings may damage the device.
- The device is not guaranteed to function outside of its operating conditions.
- Measured on approximately 1" square of 1 oz copper.

ELECTRICAL CHARACTERISTICS

$V_{IN} = 12V$, $T_A = +25^\circ C$, unless otherwise noted.

Parameter	Symbol	Condition	Min	Typ	Max	Units
Feedback Voltage		$4.75V \leq V_{IN} \leq 25V$ $V_{COMP} < 2V$	1.198	1.222	1.246	V
Upper Switch-On Resistance				0.18		Ω
Lower Switch-On Resistance				10		Ω
Upper Switch Leakage		$V_{EN} = 0V, V_{SW} = 0V$		0	10	μA
Current Limit ⁽⁴⁾			2.4	3.0	3.6	A
Current Limit Gain. Output Current to Comp Pin Voltage				1.95		A/V
Error Amplifier Voltage Gain				400		V/V
Error Amplifier Transconductance		$\Delta I_C = \pm 10\mu A$	500	770	1100	$\mu A/V$
Oscillator Frequency			342	380	418	KHz
Short Circuit Frequency		$V_{FB} = 0V$	20	35	54	KHz
Sync Frequency		Sync Drive 0V to 2.7V	445		600	KHz

ELECTRICAL CHARACTERISTICS *(continued)*
 $V_{IN} = 12V$, $T_A = +25^{\circ}C$, unless otherwise noted.

Parameter	Symbol	Condition	Min	Typ	Max	Units
Maximum Duty Cycle		$V_{FB} = 1.0V$		90		%
Minimum Duty Cycle		$V_{FB} = 1.5V$			0	%
EN Shutdown Threshold Voltage		$I_{CC} > 100\mu A$	0.7	1.0	1.3	V
Enable Pull-Up Current		$V_{EN} = 0V$	1.15	1.46	1.8	μA
EN UVLO Threshold Rising		V_{EN} Rising	2.37	2.495	2.62	V
EN UVLO Threshold Hysteresis				210		mV
Supply Current (Shutdown)		$V_{EN} \leq 0.4V$		23	36	μA
Supply Current (Quiescent)		$V_{EN} \geq 2.6V$, $V_{FB} = 1.4V$		1.0	1.2	mA
Thermal Shutdown				160		$^{\circ}C$

Note:

 4) Derate current limit $0.011A/^{\circ}C$.

PIN FUNCTIONS

Pin #	Name	Description
1	BS	Bootstrap (C5). This capacitor is needed to drive the power switch's gate above the supply voltage. It is connected between SW and BS pins to form a floating supply across the power switch driver. The voltage across C5 is about 5V and is supplied by the internal +5V supply when the SW pin voltage is low.
2	IN	Supply Voltage. The MP1580 operates from a +4.75V to +25V unregulated input. C1 is needed to prevent large voltage spikes from appearing at the input.
3	SW	Switch. This connects the inductor to either IN through M1 or to GND through M2.
4	GND	Ground. This pin is the voltage reference for the regulated output voltage. For this reason care must be taken in its layout. This node should be placed outside of the D1 to C1 ground path to prevent switching current spikes from inducing voltage noise into the part.
5	FB	Feedback. An external resistor divider from the output to GND, tapped to the FB pin sets the output voltage. To prevent current limit run away during a short circuit fault condition the frequency foldback comparator lowers the oscillator frequency when the FB voltage is below 700mV.
6	COMP	Compensation. This node is the output of the transconductance error amplifier and the input to the current comparator. Frequency compensation is done at this node by connecting a series R-C to ground. See the compensation section for exact details.
7	EN	Enable/UVLO. A voltage greater than 2.62V enables operation. For complete low current shutdown the EN pin voltage needs to be less than 700mV.
8	SYNC	Synchronization Input. This pin is used to synchronize the internal oscillator frequency to an external source. There is an internal 11k Ω pull down resistor to GND; therefore leave SYNC unconnected if unused.

OPERATION

The MP1580 is a current mode regulator; the COMP pin voltage is proportional to the peak inductor current. At the beginning of a cycle: the upper transistor M1 is off; the lower transistor M2 is on (refer to Figure 1); the COMP pin voltage is higher than the current sense amplifier output and the current comparator's output is low. The rising edge of the 380KHz CLK signal sets the RS Flip-Flop. Its output turns off M2 and turns on M1, thus connecting the SW pin and inductor to the input supply. The increasing inductor current is sensed and amplified by the Current Sense Amplifier. Ramp compensation is summed to Current Sense Amplifier output and compared to the Error Amplifier output by the Current Comparator. When the Current Sense Amplifier plus Slope Compensation signal exceeds the COMP pin voltage, the RS Flip-Flop is reset and the

MP1580 reverts to its initial M1 off, M2 on, state. If the Current Sense Amplifier plus Slope Compensation signal does not exceed the COMP voltage, then the falling edge of the CLK resets the Flip-Flop.

The output of the Error Amplifier integrates the voltage difference between the feedback and the 1.222V bandgap reference. The polarity is such that an FB pin voltage less than 1.222V increases the COMP pin voltage. Since the COMP pin voltage is proportional to the peak inductor current, an increase in its voltage increases the current delivered to the output. The lower 10Ω switch ensures that the bootstrap capacitor voltage is charged during light load conditions. An external Schottky Diode D1 carries the inductor current when M1 is off (see Figure 1).

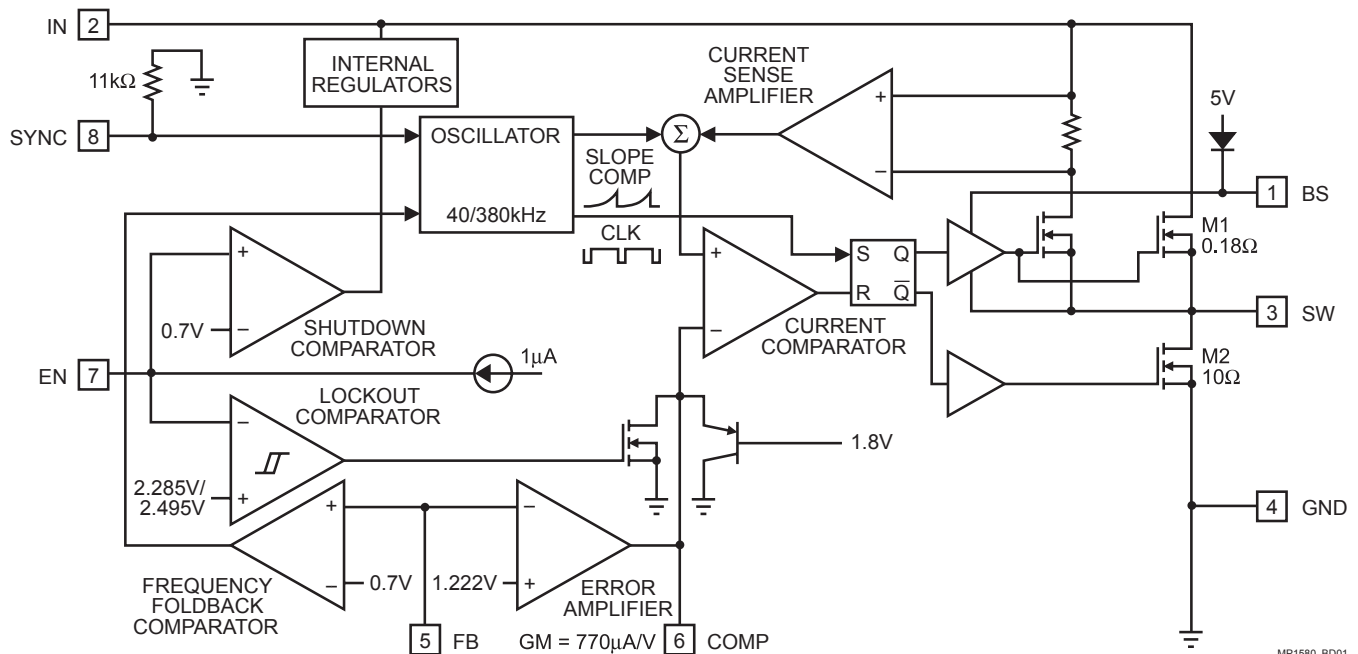

Figure 1—Functional Block Diagram

MP1580_BD01

APPLICATION INFORMATION

COMPONENT SELECTION

Sync Pin Operation

The SYNC pin driving waveform should be a square wave with a rise time less than 20ns. The Minimum High voltage level is 2.7V and the Low level is less than 0.8V. The frequency of the external sync signal needs to be greater than 445KHz.

A rising edge on the SYNC pin forces a reset of the oscillator. The upper transistor M1 is switched off immediately if it is not already off. 250ns later M1 turns on connecting SW to V_{IN} .

Setting the Output Voltage

The output voltage is set using a resistive voltage divider from the output to FB (see Figure 3). The voltage divider divides the output voltage down by the ratio:

$$V_{FB} = V_{OUT} \frac{R2}{R1 + R2}$$

Where V_{FB} is the feedback voltage and V_{OUT} is the output voltage.

Thus the output voltage is:

$$V_{OUT} = 1.222 \times \frac{R1 + R2}{R2}$$

$R2$ can be as high as 100k Ω , but a typical value is 10k Ω . Using this value, $R1$ is determined by:

$$R1 \cong 8.18 \times (V_{OUT} - 1.222)$$

For example, for a 3.3V output voltage, $R2$ is 10k Ω and $R1$ is 17k Ω .

Inductor

The inductor is required to supply constant current to the output load while being driven by the switched input voltage. A larger value inductor results in less ripple current that in turn results in lower output ripple voltage.

However, the larger value inductor has a larger physical size, higher series resistance and/or lower saturation current. Choose an inductor that does not saturate under the worst-case load conditions.

A good rule for determining the inductance is to allow the peak-to-peak ripple current in the inductor to be approximately 30% of the maximum load current. Also, make sure that the peak inductor current (the load current plus half the peak-to-peak inductor ripple current) is below the 2.4A minimum current limit.

The inductance value can be calculated by the equation:

$$L = V_{OUT} \times \frac{(V_{IN} - V_{OUT})}{V_{IN} \times f \times \Delta I}$$

Where V_{IN} is the input voltage, f is the oscillator frequency and ΔI is the peak-to-peak inductor ripple current. Table 1 lists a number of suitable inductors from various manufacturers.

Table 1—Inductor Selection Guide

Vendor/ Model	Core Type	Core Material	Package Dimensions (mm)		
			W	L	H
Sumida					
CR75	Open	Ferrite	7.0	7.8	5.5
CDH74	Open	Ferrite	7.3	8.0	5.2
CDRH5D28	Shielded	Ferrite	5.5	5.7	5.5
CDRH5D28	Shielded	Ferrite	5.5	5.7	5.5
CDRH6D28	Shielded	Ferrite	6.7	6.7	3.0
CDRH104R	Shielded	Ferrite	10.1	10.0	3.0
Toko					
D53LC Type A	Shielded	Ferrite	5.0	5.0	3.0
D75C	Shielded	Ferrite	7.6	7.6	5.1
D104C	Shielded	Ferrite	10.0	10.0	4.3
D10FL	Open	Ferrite	9.7	11.5	4.0
Coilcraft					
DO3308	Open	Ferrite	9.4	13.0	3.0
DO3316	Open	Ferrite	9.4	13.0	5.1

Input Capacitor

The input current to the step-down converter is discontinuous, so a capacitor is required to supply the AC current to the step-down converter while maintaining the DC input voltage. A low ESR capacitor is required to keep the noise at the IC to a minimum. Ceramic capacitors are preferred, but tantalum or low-ESR electrolytic capacitors will also suffice.

The input capacitor value should be greater than 10µF. The capacitor can be electrolytic, tantalum or ceramic. However, since it absorbs the input switching current it requires an adequate ripple current rating. Its RMS current rating should be greater than approximately 1/2 of the DC load current.

To ensure stable operation, C1 should be placed as close to the IN pin as possible. Alternately, a smaller high quality ceramic 0.1µF capacitor may be placed closer to the IN pin and a larger capacitor placed further away. If using this technique, it is recommended that the larger capacitor be a tantalum or electrolytic type capacitor. All ceramic capacitors should be placed close to the MP1580.

Output Capacitor

The output capacitor is required to maintain the DC output voltage. Low ESR capacitors are preferred to keep the output voltage ripple low. The characteristics of the output capacitor also affect the stability of the regulation control system. Ceramic, tantalum or low ESR electrolytic capacitors are recommended. In the case of ceramic capacitors, the impedance at the oscillator frequency is dominated by the capacitance, so the output voltage ripple is mostly independent of the ESR. The output voltage ripple is estimated to be:

$$V_{\text{RIPPLE}} \cong 1.4 \times V_{\text{IN}} \times \left(\frac{f_{\text{LC}}}{f} \right)^2$$

Where V_{RIPPLE} is the output ripple voltage, f_{LC} is the resonant frequency of the LC filter and f is the oscillator frequency.

In the case of tantalum or low-ESR electrolytic capacitors, the ESR dominates the impedance at the oscillator frequency, therefore the output ripple is calculated as:

$$V_{\text{RIPPLE}} \cong \Delta I \times R_{\text{ESR}}$$

Where V_{RIPPLE} is the output voltage ripple and R_{ESR} is the equivalent series resistance of the output capacitors.

Output Rectifier Diode

The output rectifier diode supplies the current to the inductor when the upper transistor M1 is off. To reduce losses due to the diode forward voltage and recovery times, use a Schottky rectifier.

Table 2 provides the Schottky rectifier part numbers based on the maximum input voltage and current rating.

Table 2—Schottky Rectifier Selection Guide

V_{IN} (Max)	2A Load Current	
	Part Number	Vendor
15V	30BQ015	4
20V	B220	1
	SK23	6
	SR22	6
26V	20BQ030	4
	B230	1
	SK23	6
	SR23	3, 6
	SS23	2, 3

Table 3 lists some rectifier manufacturers.

Table 3—Schottky Diode Manufacturers

Vendor	Web Site
Diodes, Inc.	www.diodes.com
Fairchild Semiconductor	www.fairchildsemi.com
General Semiconductor	www.gensemi.com
International Rectifier	www.irf.com
On Semiconductor	www.onsemi.com
Pan Jit International	www.panjit.com.tw

Choose a rectifier that has a maximum reverse voltage rating greater than the maximum input voltage, and a current rating greater than the maximum load current.

Compensation

The system stability is controlled through the COMP pin. COMP is the output of the internal transconductance error amplifier. A series capacitor-resistor combination sets a pole-zero combination to control the characteristics of the control system.

The DC loop gain is:

$$A_{VDC} = R_{LOAD} \times G_{CS} \times A_{VEA} \times \frac{V_{FB}}{V_{OUT}}$$

Where A_{VEA} is the transconductance error amplifier voltage gain, 400 V/V, G_{CS} is the current sense gain, (roughly the output current divided by the voltage at COMP), 1.95 A/V and R_{LOAD} is the load resistance (V_{OUT} / I_{OUT} where I_{OUT} is the output load current).

The system has 2 poles of importance, one is due to the compensation capacitor (C3), and the other is due to the output capacitor (C2). These are:

$$f_{P1} = \frac{G_{EA}}{2\pi \times C3 \times A_{VEA}}$$

Where P1 is the first pole and G_{EA} is the error amplifier transconductance (770 μ A/V).

and

$$f_{P2} = \frac{1}{2\pi \times C2 \times R_{LOAD}}$$

The system has one zero of importance, due to the compensation capacitor (C3) and the compensation resistor (R3). The zero is:

$$f_{Z1} = \frac{1}{2\pi \times C3 \times R3}$$

If a large value capacitor (C2) with relatively high equivalent-series-resistance (ESR) is used, the zero due to the capacitance and ESR of the output capacitor can be compensated by a third pole set by R3 and C6. The pole is:

$$f_{P3} = \frac{1}{2\pi \times C6 \times R3}$$

The system crossover frequency (the frequency where the loop gain drops to 1, or 0dB) is important. A good rule of thumb is to set the crossover frequency to approximately 1/10 of the switching frequency.

In this case, the switching frequency is 380KHz, so use a crossover frequency, f_C , of 40KHz. Lower crossover frequencies result in slower response and worse transient load recovery. Higher crossover frequencies can result in instability.

Choosing the Compensation Components

The values of the compensation components given in Table 4 yield a stable control loop for the output voltage and capacitor given.

Table 4—Compensation Values for Typical Output Voltage/Capacitor Combinations

V _{OUT}	C2	R3	C3	C6
2.5V	22 μ F Ceramic	7.5k Ω	2.2nF	None
3.3V	22 μ F Ceramic	10k Ω	2nF	None
5V	22 μ F Ceramic	15k Ω	1.2nF	None
12V	22 μ F Ceramic	33k Ω	1nF	None
2.5V	560 μ F/6.3V (30m Ω ESR)	200k Ω	1nF	100pF
3.3V	560 μ F/6.3V (30m Ω ESR)	200k Ω	1nF	82pF
5V	470 μ F/10V (30m Ω ESR)	250k Ω	1nF	56pF
12V	220 μ F/25V (30m Ω ESR)	250k Ω	1nF	27pF

To optimize the compensation components for conditions not listed in Table 4, use the following procedure:

Choose the compensation resistor to set the desired crossover frequency. Determine the value by the following equation:

$$R3 = \frac{2\pi \times C2 \times f_C}{G_{EA} \times G_{CS}} \times \frac{V_{OUT}}{V_{FB}}$$

Putting in the known constants and setting the crossover frequency to the desired 40KHz:

$$R3 \approx 1.37 \times 10^8 \times C2 \times V_{OUT}$$

Choose the compensation capacitor to set the zero below 1/4 of the crossover frequency. Determine the value by the following equation:

$$C3 > \frac{0.22 \times C2 \times V_{OUT}}{R3}$$

Determine if the second compensation capacitor, C6, is required. It is required if the ESR zero of the output capacitor happens at less than four times the crossover frequency. Or:

$$8\pi \times C2 \times R_{ESR} \times f_C \geq 1$$

or

$$\frac{7.34 \times 10^{-5} \times R3 \times R_{ESR}}{V_{OUT}} \geq 1$$

If this is the case, add the second compensation capacitor. Determine the value by the equation:

$$C6 = \frac{C2 \times R_{ESR(MAX)}}{R3}$$

Where $R_{ESR(MAX)}$ is the maximum ESR of the output capacitor.

For example:

$$V_{OUT} = 3.3V$$

C2= 22 μ F Ceramic (ESR = 10m Ω)

$$R3 \approx (1.37 \times 10^8) \times (22 \times 10^{-6}) \times (3.3) = 9.9k\Omega$$

Use the nearest standard value of 10k Ω .

$$C3 > \frac{0.22 \times (22 \times 10^{-6}) \times 3.3}{10 \times 10^3} = 1.6nF$$

Use a standard value of 2nF

$$2\pi \times C2 \times R_{ESR} \times f_C = 0.014$$

which is less than 1, therefore no second compensation capacitor is required.

Table 5—Recommended Components for Standard Output Voltages

V _{OUT}	R1	L1 Minimum
1.22V	0 Ω	6.8 μ H
1.5V	2.32k Ω	6.8 μ H
1.8V	4.75k Ω	10 μ H
2.5V	10.5k Ω	10 μ H
3.3V	16.9k Ω	15 μ H
5.0V	30.9k Ω	22 μ H

Negative Output Voltage

The MP1580 can be configured as a buck-boost regulator to supply negative output voltage.

Because the GND pin of the IC is now connected to the negative output voltage, the maximum allowable input voltage is the IC input voltage rating (25V) minus the negative output voltage value. A typical application circuit is shown in Figure 3.

External Bootstrap Diode

It is recommended that an external bootstrap diode be added when the system has a 5V fixed input or the power supply generates a 5V output. This helps improve the efficiency of the regulator. The bootstrap diode can be a low cost one such as IN4148 or BAT54.

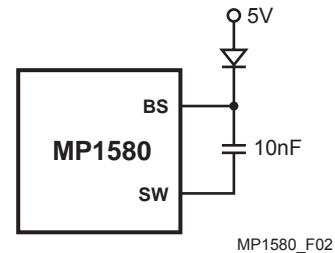
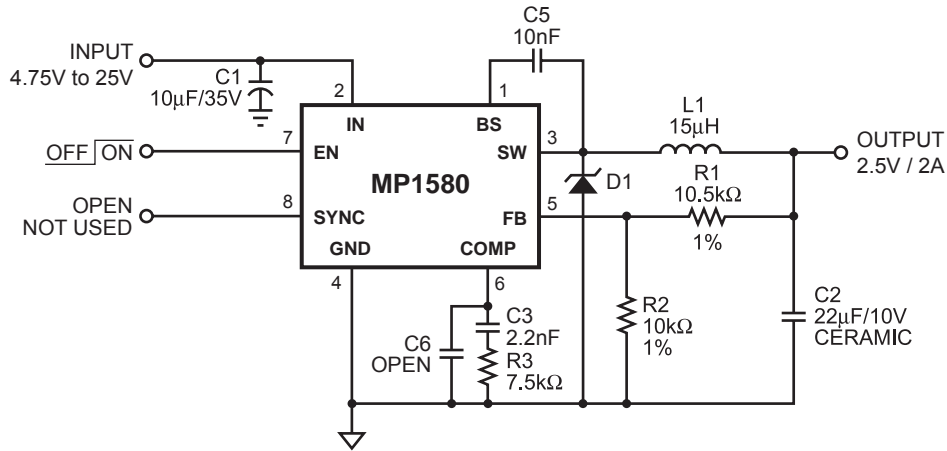

Figure 2—External Bootstrap Diode

This diode is also recommended for high duty cycle operation (when $\frac{V_{OUT}}{V_{IN}} > 65\%$) and high output voltage ($V_{OUT} > 12V$) applications.

TYPICAL APPLICATION CIRCUITS



MP1580_F03

Figure 3—Application Circuit for -5V Supply

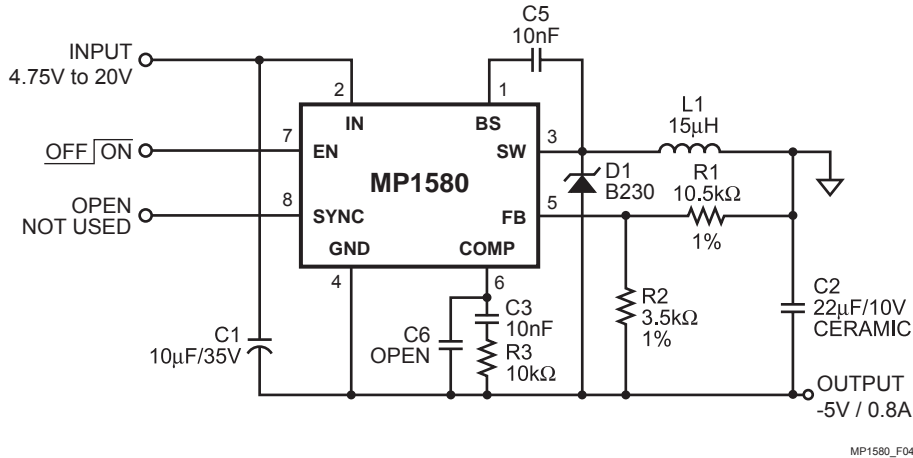

MP1580_F04

Figure 4—MP1580 with Murata 22µF/10V Ceramic Output Capacitor

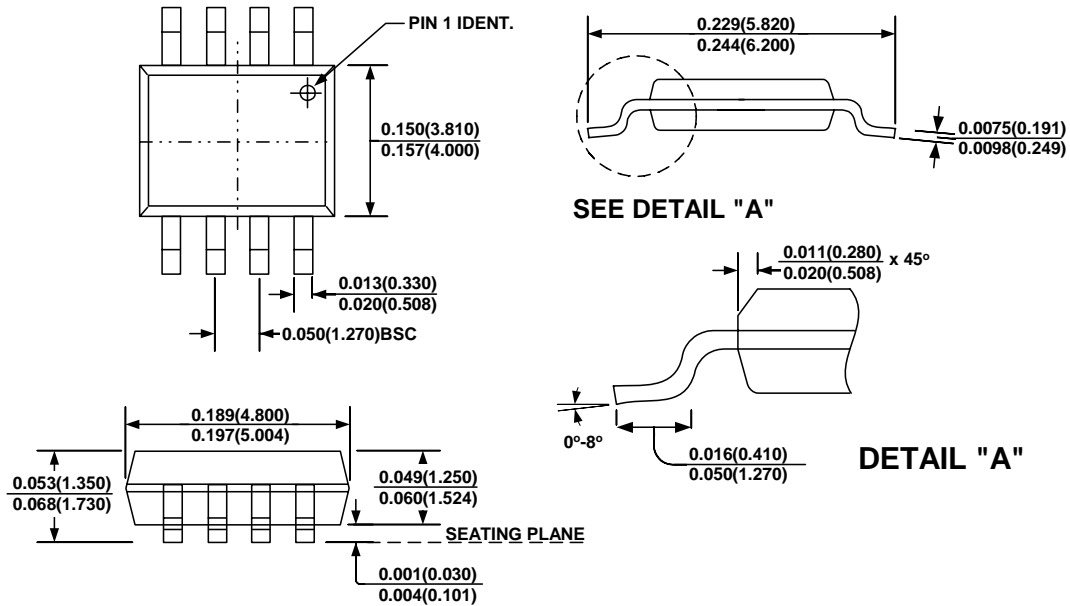
PACKAGE INFORMATION
SOIC8

NOTE:

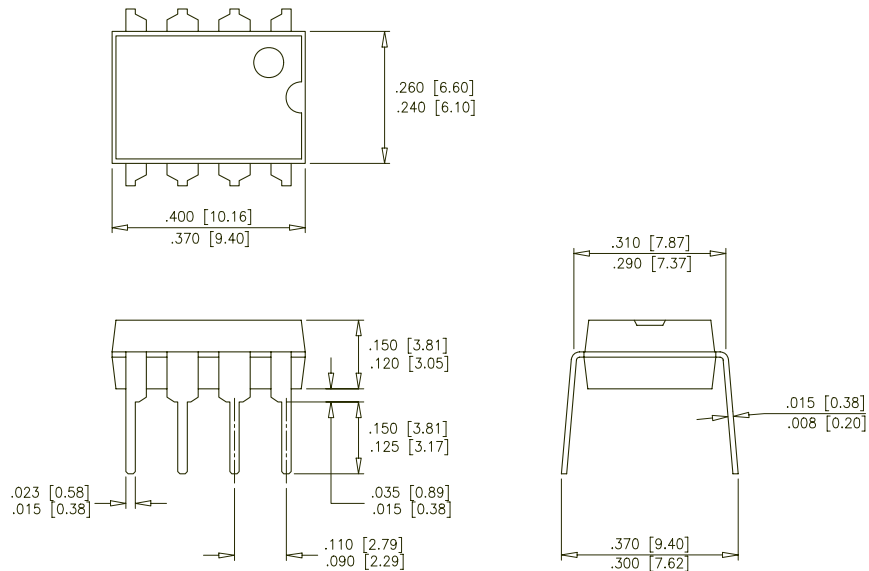
1) Control dimension is in inches. Dimension in bracket is millimeters.

PDIP8

NOTICE: The information in this document is subject to change without notice. Please contact MPS for current specifications. Users should warrant and guarantee that third party Intellectual Property rights are not infringed upon when integrating MPS products into any application. MPS will not assume any legal responsibility for any said applications.

AMEYA360

Components Supply Platform

Authorized Distribution Brand :



Website :

Welcome to visit www.ameya360.com

Contact Us :

➤ Address :

401 Building No.5, JiuGe Business Center, Lane 2301, Yishan Rd
Minhang District, Shanghai , China

➤ Sales :

Direct +86 (21) 6401-6692

Email amall@ameya360.com

QQ 800077892

Skype [ameyasales1](#) [ameyasales2](#)

➤ Customer Service :

Email service@ameya360.com

➤ Partnership :

Tel +86 (21) 64016692-8333

Email mkt@ameya360.com