

# PMT Panel Mount Power Supply

## 36V 350W 1 Phase / PMT-36V350W1A□

# PMT

### Highlights & Features

- AC input range selectable by switch
- Full aluminium casing for light weight and corrosion resistant handling
- Built-in automatic fan speed control circuit
- MTBF > 700,000 hrs. as per Telcordia SR-332
- Short Circuit / Overvoltage / Overload / Over Temperature Protections

### Safety Standards



CB Certified for worldwide use

**Model Number:** PMT-36V350W1A□  
**Unit Weight:** 0.83 kg  
**Dimensions (L x W x D):** 215 x 115 x 50 mm



### General Description

The new PMT series of panel mount power supplies is the latest offering from one of the world's largest power supply manufacturers and solution providers - Delta. PMT-36V350W1A□ offers a nominal output voltage of 36V with a wide operating temperature range from -10°C to +70°C and can withstand shock and vibration (in accordance to IEC 60068-2-27 and IEC 60068-2-6 respectively). In addition to features like overvoltage and overload protections, Delta's PMT series of panel mount power supplies is unlike many other brands in the same price level. The PMT series is designed for cost competitive markets without compromising the quality of the components and product specifications. The series of products has an expected life time of 10 years and will have no output power de-rating from 100Vac to 132Vac & 200Vac to 264Vac.

### Model Information

PMT Panel Mount Power Supply

Model Number	Input Voltage Range	Output Voltage	Output Current
PMT-36V350W1A□	90-132Vac, 180-264Vac (Selectable by Switch)	36Vdc	9.70A

### Model Numbering

							CC Code**
PM	T –	36V	350W	1	A	□	□
Panel Mount	Product Type T – Enclosed	Output Voltage	Output Power	Single Phase	No PFC	Connector Type R – Terminal Block K – Front Face*	Blank – Without connector cover A – With connector cover

\*Options

\*\*For Terminal Block

# PMT Panel Mount Power Supply

## 36V 350W 1 Phase / PMT-36V350W1A□

### Specifications

#### Input Ratings / Characteristics

Nominal Input Voltage	100-120Vac, 200-240Vac (Selectable by Switch)
Input Voltage Range	90-132Vac, 180-264Vac (Selectable by Switch)
Nominal Input Frequency	50-60Hz
Input Frequency Range	47-63Hz
Input Current	7.00A typ. @ 115Vac, 4.00A typ. @ 230Vac
Efficiency at 100% Load	87.5% typ. @ 230Vac
Max Inrush Current (Cold Start)	40A typ. @ 115Vac, 60A typ. @ 230Vac
Leakage Current	< 3.5mA @ 240Vac

#### Output Ratings / Characteristics

Nominal Output Voltage	36Vdc
Output Voltage Tolerance	± 1% (initial set point tolerance from factory)
Output Voltage Adjustment Range	32.4-39.6Vdc
Output Current	9.70A
Output Power	349.2W
Line Regulation	± 0.5% typ.
Load Regulation	± 1% typ.
PARD (20MHz)	< 240mVpp
Rise Time	< 50ms @ nominal input (100% load)
Start-up Time	< 1000ms @ nominal input (100% load)
Hold-up Time	16ms typ. @ 115Vac, 20ms typ. @ 230Vac
Dynamic Response (Overshoot & Undershoot O/P Voltage)	± 5% @ 10-50% load and 50-100% load
Start-up with Capacitive Loads	8,000µF Max

### Mechanical

Case Cover / Chassis	Aluminium	
Dimensions (L x W x D)	215 x 115 x 50 mm	
Unit Weight	0.83 kg	
Indicator	Green LED (DC OK)	
Cooling System	Forced Cooling	
Terminal	PMT-36V350W1AR□	M3.5 x 9 Pins (Rated 300V/20A)
	PMT-36V350W1AK	M3.5 x 9 Pins (Rated 300V/15A)
Wire	AWG 22-12	

# PMT Panel Mount Power Supply

## 36V 350W 1 Phase / PMT-36V350W1A□

### Environment

Surrounding Air Temperature	Operating	-10°C to +70°C
	Storage	-25°C to +85°C
Power De-rating	> 50°C de-rate power by 2.5% / °C < 100Vac de-rate power by 3% / V	
Operating Humidity	5 to 95% RH (Non-Condensing)	
Operating Altitude	0 to 5,000 Meters	
Shock Test (Non-Operating)	IEC 60068-2-27, Half Sine: 50G for a duration of 11ms, 3 times per direction, 18 times in total	
Vibration	Operating	IEC 60068-2-6, Sine Wave: 10Hz to 150Hz @ 25m/S <sup>2</sup> (2.5G peak); 90 min per axis for all X, Y, Z direction
	Non-Operating	IEC 60068-2-6, Random: 5Hz to 500Hz @ 2.09Grms peak; 20 min per axis for all X, Y, Z direction
Pollution Degree	2	

### Protections

Overvoltage	41.4V~48.6V, Latch Mode
Overload / Overcurrent	105%~150% of rated load current, Hiccup Mode, Non-Latching (Auto-Recovery)
Over Temperature	Hiccup Mode, Non-Latching (Auto-Recovery when the fault is removed)
Short Circuit	Hiccup Mode, Non-Latching (Auto-Recovery when the fault is removed)
Protection Against Shock	Class I with PE* connection

\*PE: Primary Earth

### Reliability Data

MTBF	> 700,000 hrs. as per Telcordia SR-332 I/P: 100Vac, O/P: 100% load, Ta: 35°C
Expected Cap Life Time	10 years (115Vac & 230Vac, 50% load @ 40°C)

### Safety Standards / Directives

Electrical Safety	TUV Bauart to EN 60950-1, UL/cUL recognized to UL 60950-1 and CSA C22.2 No. 60950-1 (File No. E131881), CB scheme to IEC 60950-1	
CE	In conformance with EMC Directive 2004/108/EC and Low Voltage Directive 2006/95/EC	
Material and Parts	RoHS Directive 2011/65/EU Compliant	
Galvanic Isolation	Input to Output	3.0KVac
	Input to Ground	1.5KVac
	Output to Ground	0.5KVac

# PMT Panel Mount Power Supply

## 36V 350W 1 Phase / PMT-36V350W1A

### EMC

EMC / Emissions		CISPR 22, EN 55022, EN 55011, FCC Title 47: Class B
Immunity to		EN 55024
Electrostatic Discharge	IEC 61000-4-2	Level 4 Criteria A <sup>1)</sup> Air Discharge: 15kV Contact Discharge: 8kV
Radiated Field	IEC 61000-4-3	Level 3 Criteria A <sup>1)</sup> 80MHz-1GHz, 10V/M with 1kHz tone / 80% modulation
Electrical Fast Transient / Burst	IEC 61000-4-4	Level 3 Criteria A <sup>1)</sup> 2kV
Surge	IEC 61000-4-5	Level 3 Criteria A <sup>1)</sup> Common Mode <sup>2)</sup> : 2kV Differential Mode <sup>3)</sup> : 1kV
Conducted	IEC 61000-4-6	Level 3 Criteria A <sup>1)</sup> 150kHz-80MHz, 10Vrms
Power Frequency Magnetic Fields	IEC 61000-4-8	Criteria A <sup>1)</sup> 10A/Meter
Voltage Dips	IEC 61000-4-11	100% dip; 1 cycle (20ms); Self Recoverable
Low Energy Pulse Test (Ring Wave)	IEC 61000-4-12	Level 3 Criteria A <sup>1)</sup> Common Mode <sup>2)</sup> : 2kV Differential Mode <sup>3)</sup> : 1kV
Harmonic Current Emission		NA
Voltage Fluctuation and Flicker*		IEC/EN 61000-3-3

\*Fulfills tested conditions

1) Criteria A: Normal performance within the specification limits

2) Asymmetrical: Common mode (Line to earth)

3) Symmetrical: Differential mode (Line to line)

# PMT Panel Mount Power Supply

36V 350W 1 Phase / PMT-36V350W1A□

## Block Diagram

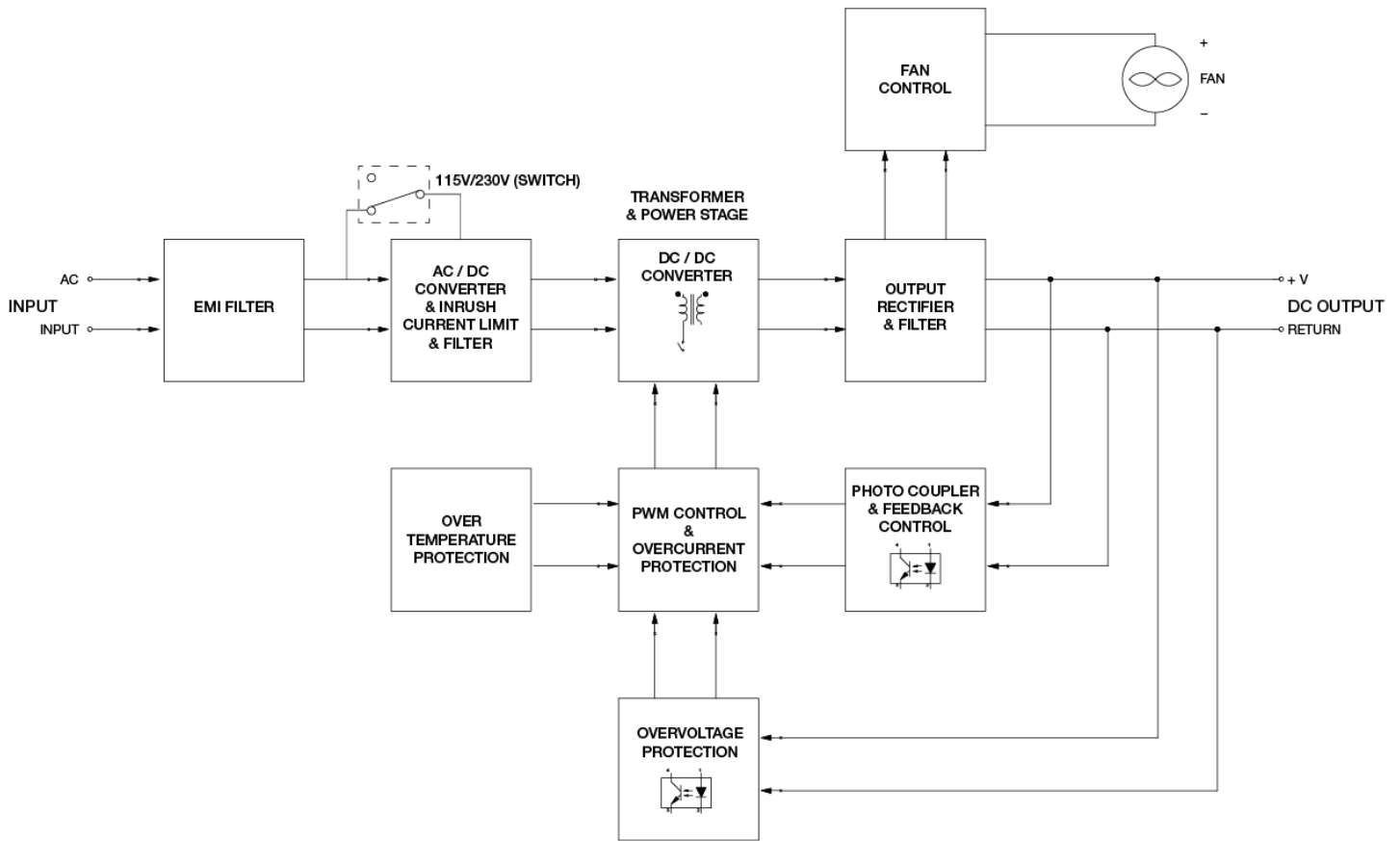

## Device Description

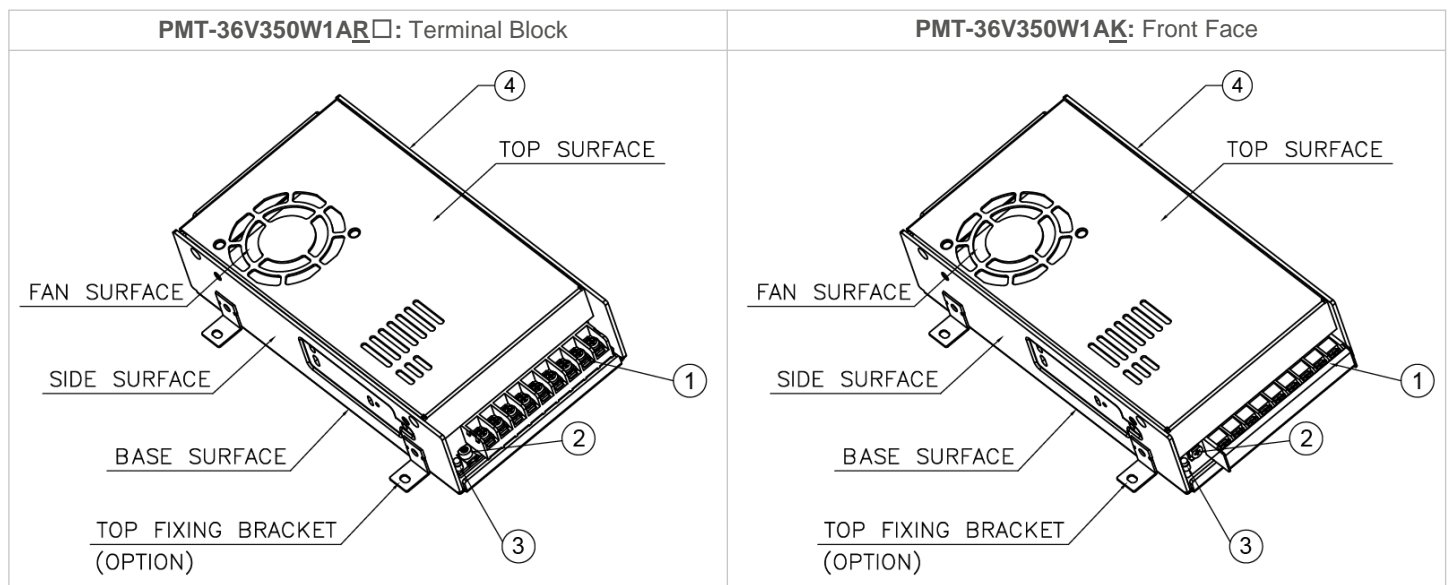

- 1) Input & Output terminal block connector
- 2) DC voltage adjustment potentiometer
- 3) DC OK control LED (Green)
- 4) AC selectable switch

# PMT Panel Mount Power Supply

36V 350W 1 Phase / PMT-36V350W1A □

## Dimensions

L x W x D: 215 x 115 x 50 mm (PMT-36V350W1A □: Terminal Block)

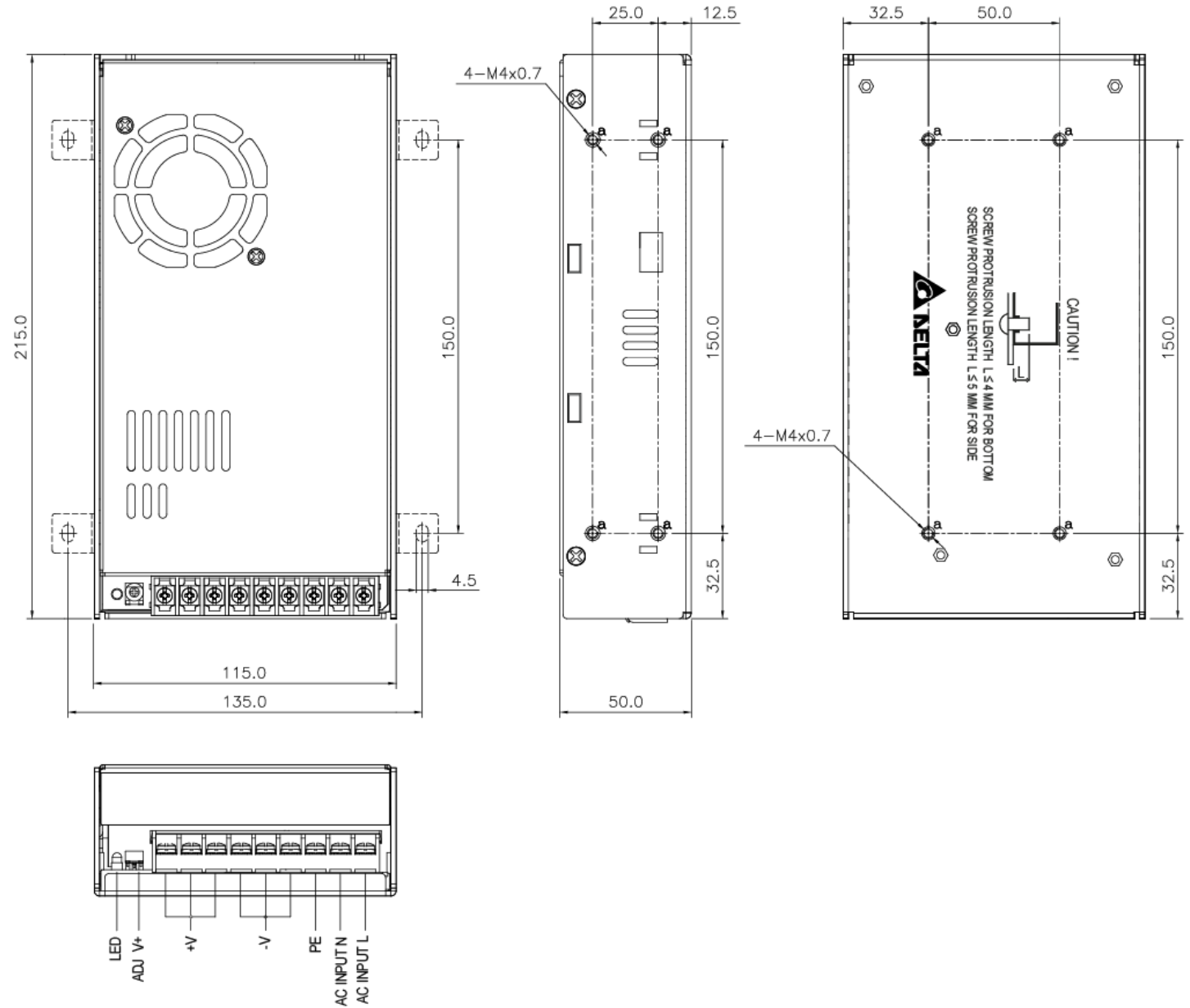

# PMT Panel Mount Power Supply

36V 350W 1 Phase / PMT-36V350W1A □

L x W x D: 215 x 115 x 50 mm (PMT-36V350W1AK: Front Face)

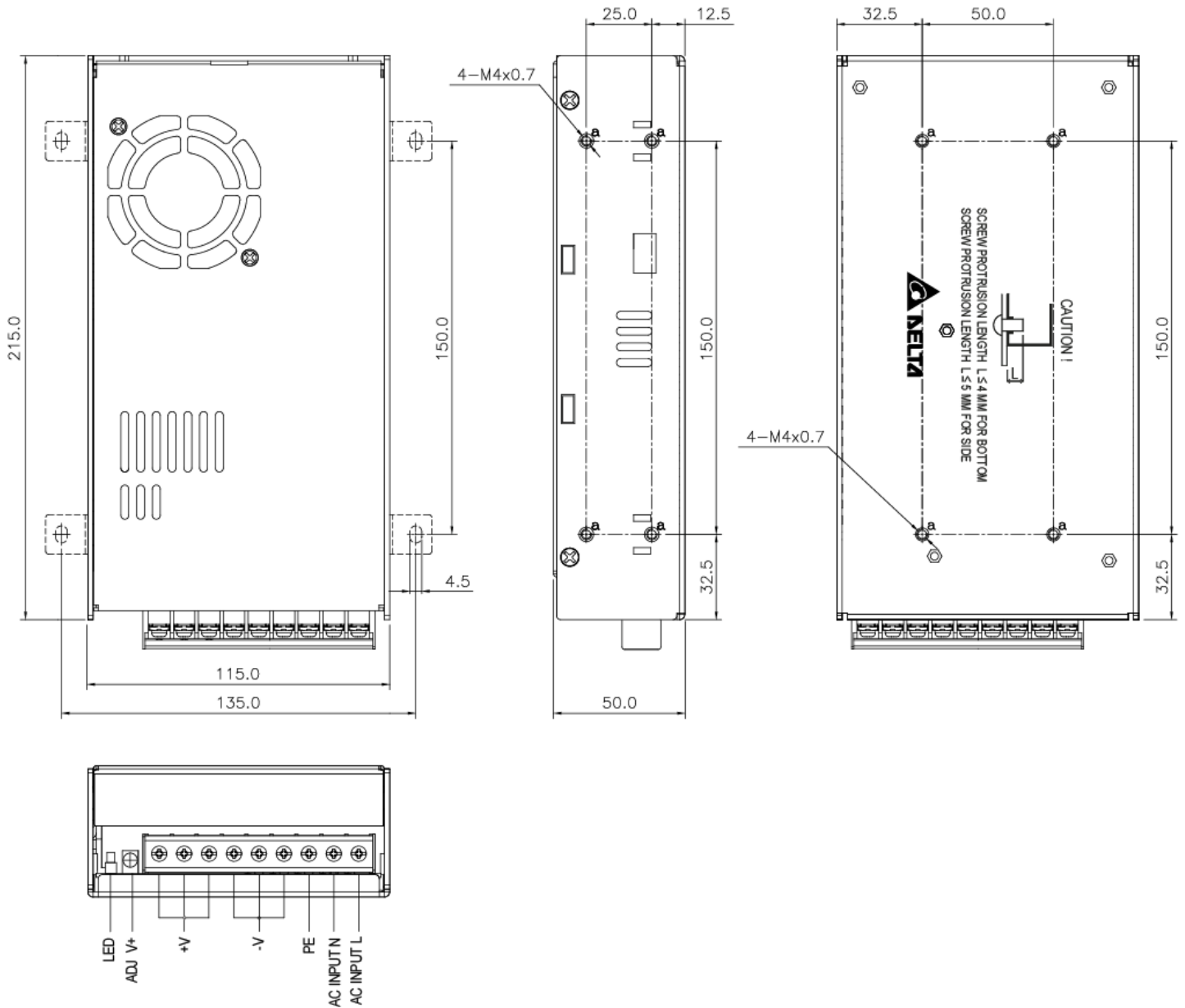

# PMT Panel Mount Power Supply

## 36V 350W 1 Phase / PMT-36V350W1A □

### Engineering Data

#### De-rating

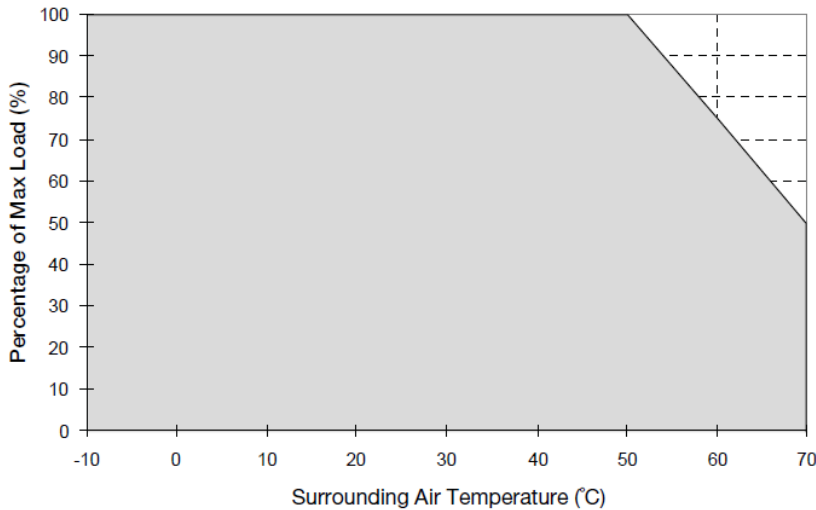
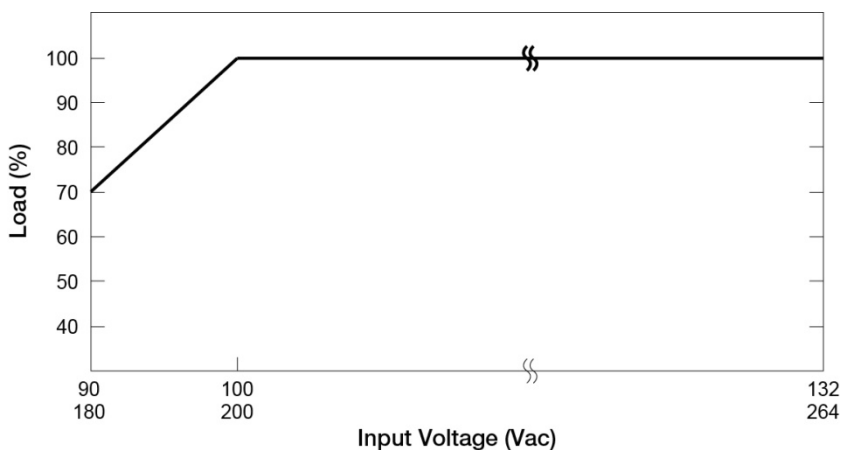

**Fig. 1 De-rating for Vertical and Horizontal Mounting Orientation**  
 > 50°C de-rate power by 2.5% / °C

#### Note

1. Power supply components may degrade, or be damaged, when the power supply is continuously used outside the shaded region, refer to the graph shown in Fig. 1.
2. If the output capacity is not reduced when the surrounding air temperature >70°C, the device will run into Over Temperature Protection. When activated, the output voltage will go into bouncing mode and will recover when the surrounding air temperature is lowered or the load is reduced as far as necessary to keep the device in working condition.
3. To ensure sufficient convection cooling, always maintain a distance of ≥ 20mm from fan ventilated surfaces while the device is in operation.
4. Depending on the surrounding air temperature and output load delivered by the power supply, the device housing can be very hot!
5. If the device has to be mounted in any other orientation, please do not hesitate to contact [info@deltapsu.com](mailto:info@deltapsu.com) for more details.

#### Output De-rating VS. Input Voltage



- No output power de-rating for the input voltage from 100Vac to 132Vac & 200Vac to 264Vac

# PMT Panel Mount Power Supply

## 36V 350W 1 Phase / PMT-36V350W1A□

### Assembly & Installation

- Ⓐ Side Mounting: Fig. 2 and Fig. 3 show the mounting hole locations for power supply assembly onto a metal mounting surface. The power supply shall be mounted on minimum of 4 mounting holes using M4 screw maximum 5mm length (Refer to Fig. 4). This is to maintain a safety distance between the screw and internal components.
- Ⓑ Base Mounting: Fig. 2 and Fig. 3 show the mounting hole locations for power supply assembly onto a metal mounting surface. The power supply shall be mounted on minimum of 4 mounting holes using M4 screw maximum 4mm length (Refer to Fig. 4).
- Ⓒ Connector
- Ⓓ This surface belongs to customer's end system or panel where the power supply is mounted.

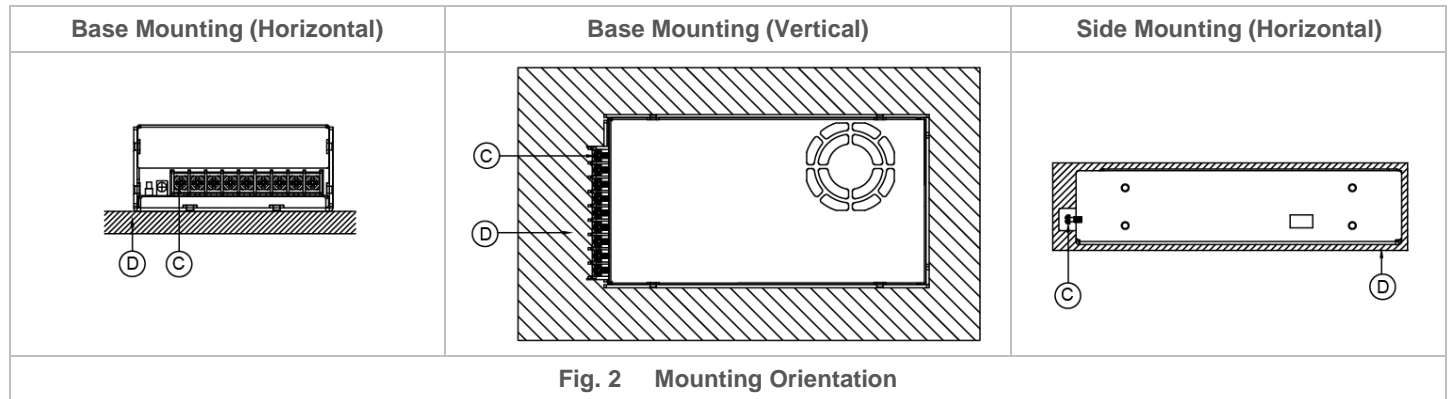

- Use flexible cable (stranded or solid) of AWG No. 22-12. The input/output connectors' allowable current is 23A max per pin. User should calculate and select the suitable wire specification (type/quantity/diameter) according to actual output current. The torque at the connector shall not exceed 13Kgf.cm. The insulation stripping length should not exceed 0.275" or 7mm.
- Recommended mounting torque of the product and its mounting accessories is 9~12Kgf.cm.

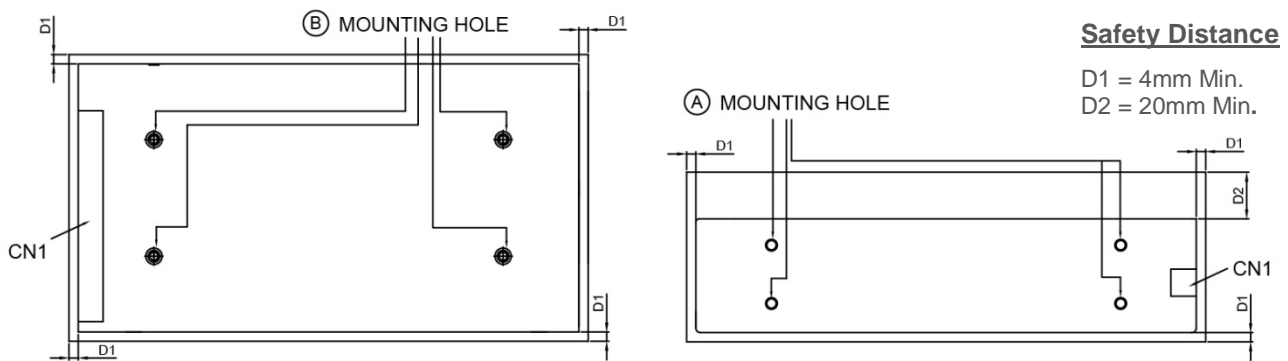

**Fig. 3 Mounting Hole Locations and the Safety Distance**

For safety reasons, please ensure the mounted device is kept at  $\geq 4\text{mm}$  safety distance at all sides from other components and equipments. In addition, to ensure sufficient convection cooling, always maintain a distance of  $\geq 20\text{mm}$  from fan ventilated surfaces while the device is in operation. Please insert an insulation sheet between the system and product, if the safety distance is  $< 4\text{mm}$ .

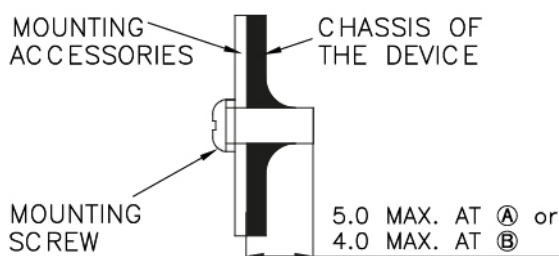

- Only use M4 screw  $\leq 5\text{mm}$  through the base mounting holes at Ⓐ. This is to keep a safe distance between the screw and internal components.
- Only use M4 screw  $\leq 4\text{mm}$  through the base mounting holes at Ⓑ.

**Fig. 4 Assembly Reference**

# PMT Panel Mount Power Supply

## 36V 350W 1 Phase / PMT-36V350W1A□

### Safety Instructions

- Must select correct AC input voltage before turning on (Refer to the “Device Description” on Page 5).
- If user's mounting orientation is not according to the recommended mounting orientations, please consult Delta for further information.
- The device is not recommended to be placed on low thermal conductive surface. For example, plastics.
- The enclosure of the device can become very hot depending on the ambient temperature and load of the power supply. Do not touch the device while it is in operation or immediately after power is turned OFF. Risk of burning!
- Do not touch the terminals while power is being supplied. Risk of electric shock.
- Prevent any foreign metal, particles or conductors from entering the device through the openings during installation. It may cause: - Electric shock; Safety Hazard; Fire; Product failure.
- Warning: When connecting the device, secure Earth connection before connecting L and N. When disconnecting the device, remove L and N connections before removing the Earth connection. The power supply must be mounted by metal screws onto a grounded metal surface. It is highly recommended that the Earth terminal on the connector be connected to the grounded metal surface.

### Accessories

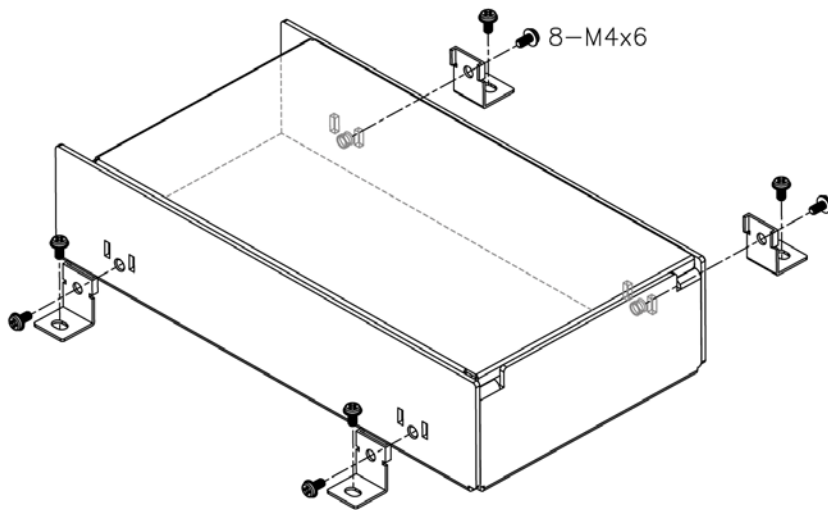

#### LM-01: Top Fixing Bracket

This bracket is used to fix the power supply onto a flat surface from the top.

# PMT Panel Mount Power Supply

## 36V 350W 1 Phase / PMT-36V350W1A

### Functions

#### Start-up Time

The time required for the output voltage to reach 90% of its set value, after the input voltage is applied.

#### Rise Time

The time required for the output voltage to change from 10% to 90% of its set value.

#### Hold-up Time

Hold up time is the time when the AC input collapses and output voltage retains regulation for a certain period of time. The time required for the output to reach 95% of its set value, after the input voltage is removed.

### ■ Graph illustrating the Start-up Time, Rise Time, and Hold-up Time

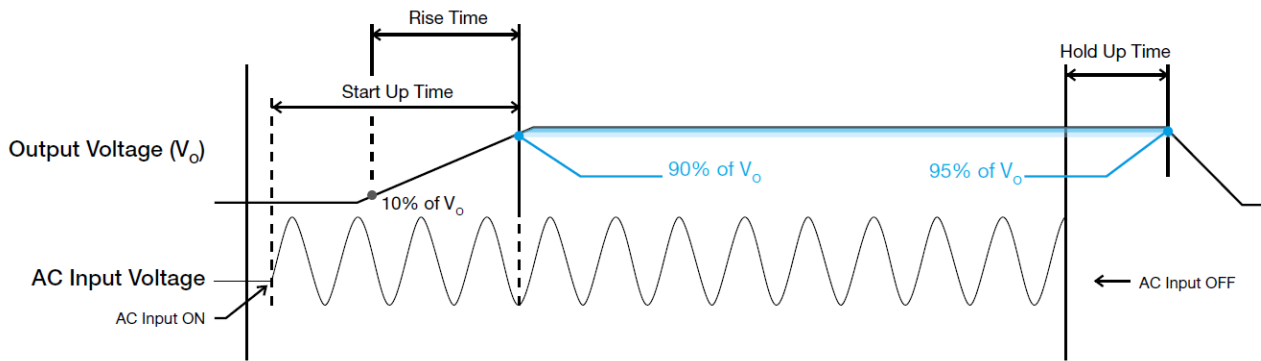

### Inrush Current

Inrush current is the peak, instantaneous, input current measured and, occurs when the input voltage is first applied. For AC input voltages, the maximum peak value of inrush current will occur during the first half cycle of the applied AC voltage. This peak value decreases exponentially during subsequent cycles of AC voltage.

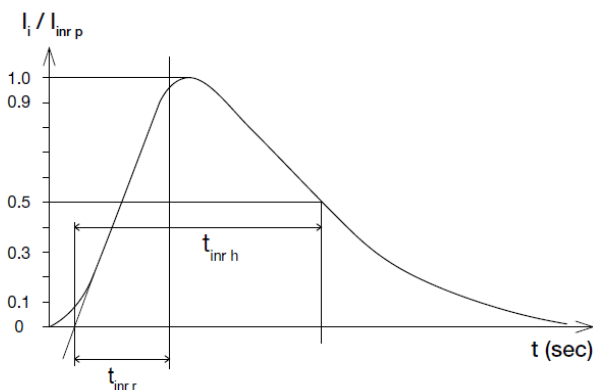

### Dynamic Response

The power supply output voltage will remain within  $\pm 5\%$  of its steady state value, when subjected to a dynamic load from 10 to 50% and 50 to 100% of its rated current.

#### ■ 10 to 50% Load

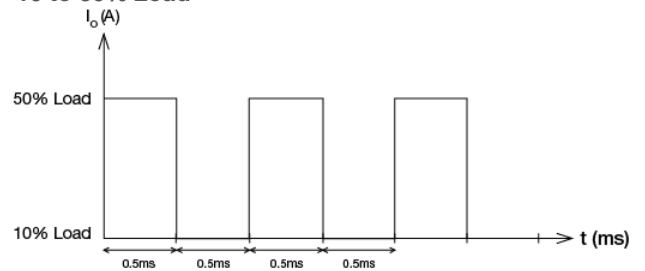

#### ■ 50 to 100% Load

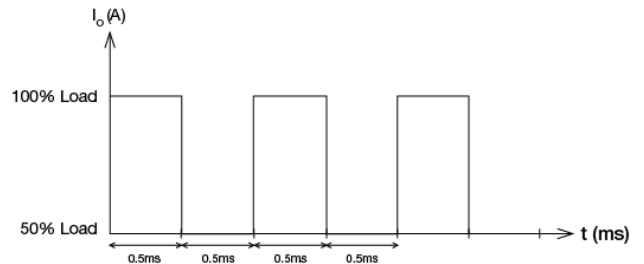

# PMT Panel Mount Power Supply

36V 350W 1 Phase / PMT-36V350W1A □

## Overload & Overcurrent Protections

The power supply's Overload (OLP) and Overcurrent (OCP) Protections will be activated when output current exceeds 105%~150% of rated load current. In such occurrence, the  $V_O$  will start to droop and once the power supply has reached its maximum power limit, the protection is activated and the power supply will go into "Hiccup mode" (Auto-Recovery). The power supply will recover once the fault condition of the OLP and OCP is removed and  $I_O$  is back within the specifications.

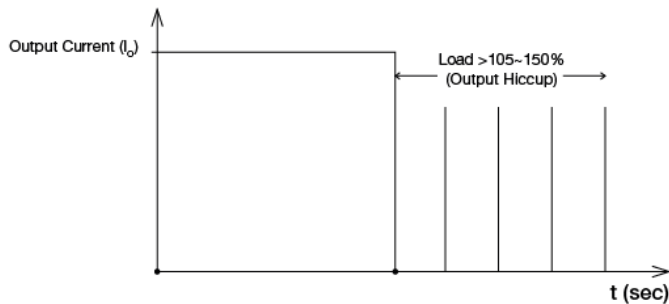

It is not recommended to prolong the duration of  $I_O$  when it is 105%~150%, since it may cause damage to the PSU.

## Short Circuit Protection

The power supply's output OLP/OCP function also provides protection against short circuits. When a short circuit is applied, the output current will operate in "Hiccup mode", as shown in the illustration in the OLP/OCP section on this page. The power supply will return to normal operation after the short circuit is removed.

## Overvoltage Protection

The power supply's overvoltage circuit will be activated when its internal feedback circuit fails. The output voltage shall not exceed its specifications defined on Page 3 under "Protections".

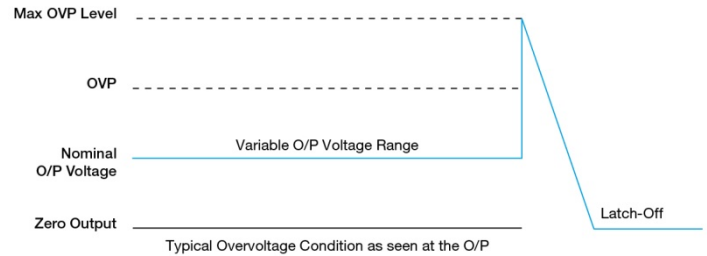

## Over Temperature Protection

As mentioned above, the power supply also has Over Temperature Protection (OTP). In the event of a higher operating temperature at 100% load, the power supply will run into OTP when the operating temperature is beyond what is recommended in the de-rating graph. When activated, the output voltage will go into bouncing mode until the temperature drops to its normal operating temperature as recommended in the de-rating graph.

# PMT Panel Mount Power Supply

## 36V 350W 1 Phase / PMT-36V350W1A□

### Operating Mode

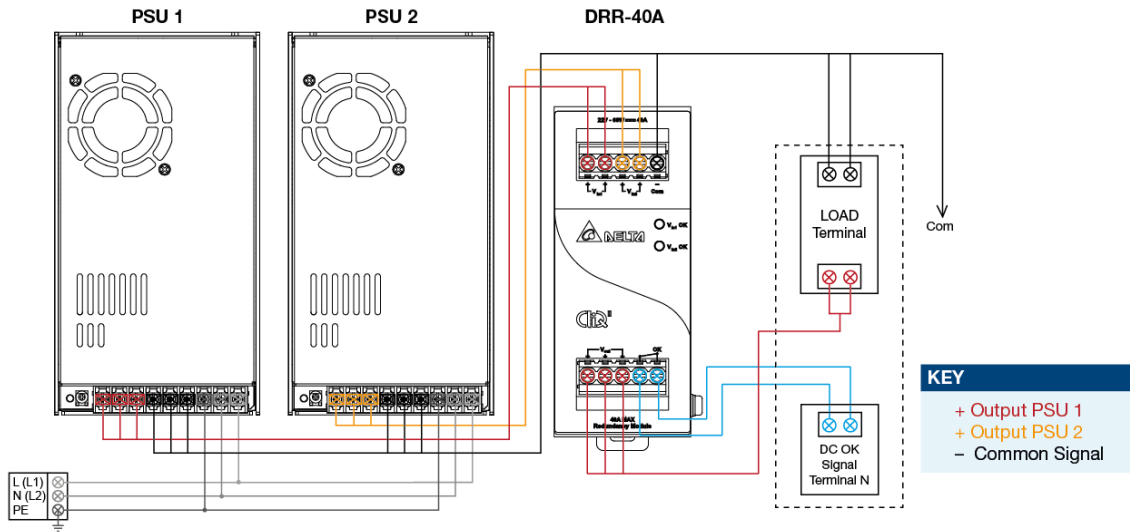

Fig. 5 Redundancy / Parallel Operation Connection Diagram

#### ■ Redundancy Operation

In order to ensure proper redundancy operation for the power supply unit (PSU), ensure that the output voltage difference between the two units is kept at 0.36~0.40V for 36V supplies. Follow simple steps given below to verify:

**Step 1.**  
Measure output voltage of PSU 1 and PSU 2. If PSU 1 is the master unit, then  $V_O$  of PSU 1 must be higher than PSU 2. In order to set the output voltage, connect the power supply to 50% load and set the PSU 1 and PSU 2 output voltage.

**Step 2.**  
Connect the right DRR module, 40A as per the system requirement to the power supply units PSU 1 and PSU 2 at  $V_{in 1}$  &  $V_{in 2}$  respectively.

**Step 3.**  
Connect the system load from  $V_{out}$ . Please note that output voltage  $V_{out}$  from DRR module will be =  $V_O$  (output voltage of power supply) -  $V_{drop}^*$  (in DRR module).

#### ■ Parallel Operation

These DRR modules can also be used for Parallel function in order to increase the output power by N+1 (e.g. 2.5A + 2.5A = 5A or 2.5A + 2.5A + 2.5A = 7.5A) or current sharing, and thus increasing the power supply and system reliability. Though the PMT-36V350W1A□ is not designed for current sharing, a good current sharing between two power supplies can be achieved by following simple steps as below (Refer to Fig. 5 for the Connection Diagram).

**Step 1.**  
Set output load condition for both supplies at 50% and measure the output voltages.

**Step 2.**  
Adjust output voltages to the same level or within  $\pm 25mV$  difference.

**Step 3.**  
Connect PSU 1 and PSU 2 with the DRR-40A module and measure at  $V_{in 1}$  &  $V_{in 2}$  to verify the voltage difference. Ensure the voltages are within  $\pm 25mV$ .

**Step 4.**  
Output voltage from DRR module  $V_{out}$  will be =  $V_O$  (output voltage of power supply) -  $V_{drop}^*$  (in DRR module).

\* $V_{drop}$  will vary from 0.60V to 0.90V (Typical 0.65V) depending on the load current and surrounding air temperature.

# PMT Panel Mount Power Supply

36V 350W 1 Phase / PMT-36V350W1A□

## Others

Delta RoHS Compliant



### Restriction of the usage of hazardous substances

The European directive 2011/65/EU limits the maximum impurity level of homogeneous materials such as lead, mercury, cadmium, chrome, polybrominated flame retardants PBB and PBDE for the use in electrical and electronic equipment. RoHS is the abbreviation for "Restriction of the use of certain hazardous substances in electrical and electronic equipment".

This product conforms to this standard.

# AMEYA360

## Components Supply Platform

### Authorized Distribution Brand :



### Website :

Welcome to visit [www.ameya360.com](http://www.ameya360.com)

### Contact Us :

#### ➤ Address :

401 Building No.5, JiuGe Business Center, Lane 2301, Yishan Rd  
Minhang District, Shanghai , China

#### ➤ Sales :

Direct +86 (21) 6401-6692

Email [amall@ameya360.com](mailto:amall@ameya360.com)

QQ 800077892

Skype [ameyasales1](#) [ameyasales2](#)

#### ➤ Customer Service :

Email [service@ameya360.com](mailto:service@ameya360.com)

#### ➤ Partnership :

Tel +86 (21) 64016692-8333

Email [mkt@ameya360.com](mailto:mkt@ameya360.com)