

ACPL-K71T, ACPL-K72T, ACPL-K74T and ACPL-K75T

Automotive High Speed Low Power Digital Optocouplers

with R²Coupler™ Isolation and AEC-Q100 Grade 1 Qualification



Data Sheet



Lead (Pb) Free
RoHS 6 fully
compliant

RoHS 6 fully compliant options available;
-xxxE denotes a lead-free product

Description

The ACPL-K71T and ACPL-K72T are high speed digital CMOS optocouplers package suitable for emerging electric vehicle applications. The ACPL-K74T and ACPL-K75T are dual channel equivalent of the ACPL-K71T and ACPL-K72T respectively. All products are available in the stretched SO-8 package outline, designed to be compatible with standard surface mount processes.

ACPL-K71T and ACPL-K74T are high speed mode with fastest propagation delay (max 35ns at $I_F=10\text{mA}$) while ACPL-K72T and ACPL-K75T are low power mode with lowest LED drive current of 4mA for standard digital isolation switching.

Each channel of the digital optocoupler has a CMOS detector IC with an integrated photodiode, a high speed trans-impedance amplifier, and a voltage comparator with an output driver.

Avago R²Coupler provides with reinforced insulation and reliability that delivers safe signal isolation critical in automotive and high temperature industrial applications.

Functional Diagram

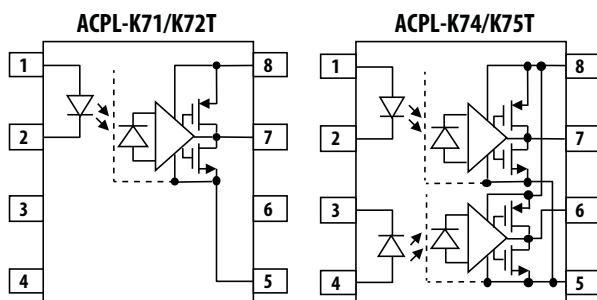

Note: The connection of a 0.1 μF bypass capacitor between pins 5 and 8 is recommended.

Features

- Qualified to AEC-Q100 Grade 1 Test Guidelines
- Automotive Wide Temperature Range: -40°C to 125°C
- High Temperature and Reliability, High Speed Digital Interface for Automotive Application.
- 5 V CMOS compatibility
- 40 kV/ μs Common-Mode Rejection at $V_{CM}=1000\text{V}$ Typ.
- Low Propagation Delay :
 - ACPL-K71T, ACPL-K74T: 25ns Typ.@ $I_F = 10\text{mA}$
 - ACPL-K72T, ACPL-K75T: 60ns Typ.@ $I_F = 4\text{mA}$
- Worldwide Safety Approval:
 - UL 1577 approval, 5kV_{RMS} /1 min.
 - CSA Approval
 - IEC/EN/DIN EN 60747-5-5

Applications

- CAN Bus and SPI Communications Interface
- High Temperature Digital/Analog Signal Isolation
- Automotive IPM Driver for DC-DC converters and motor inverters
- Power Transistor Isolation

Truth Table

LED	V _o
ON	LOW
OFF	HIGH

CAUTION: It is advised that normal static precautions be taken in handling and assembly of this component to prevent damage and/or degradation which may be induced by ESD.

Ordering Information

Part number	Option (RoHS Compliant)	Package	Surface Mount	Tape & Reel	UL 5000 V _{RMS} / 1 Minute rating	IEC/EN/DIN EN 60747-5-5	Quantity
ACPL-K71T	-000E	Stretched SO-8	X		X		80 per tube
	-060E		X		X	X	80 per tube
	-500E		X	X	X		1000 per reel
	-560E		X	X	X	X	1000 per reel
ACPL-K72T	-000E	Stretched SO-8	X		X		80 per tube
	-060E		X		X	X	80 per tube
	-500E		X	X	X		1000 per reel
	-560E		X	X	X	X	1000 per reel
ACPL-K74T	-000E	Stretched SO-8	X		X		80 per tube
	-060E		X		X	X	80 per tube
	-500E		X	X	X		1000 per reel
	-560E		X	X	X	X	1000 per reel
ACPL-K75T	-000E	Stretched SO-8	X		X		80 per tube
	-060E		X		X	X	80 per tube
	-500E		X	X	X		1000 per reel
	-560E		X	X	X	X	1000 per reel

To order, choose a part number from the part number column and combine with the desired option from the option column to form an order entry.

Example 1:

ACPL-K71T-560E to order product of SSO-8 Surface Mount package in Tape and Reel packaging with IEC/EN/DIN EN 60747-5-5 Safety Approval in RoHS compliant.

Option datasheets are available. Contact your Avago sales representative or authorized distributor for information.

Package Outline Dimensions (Stretched S08)

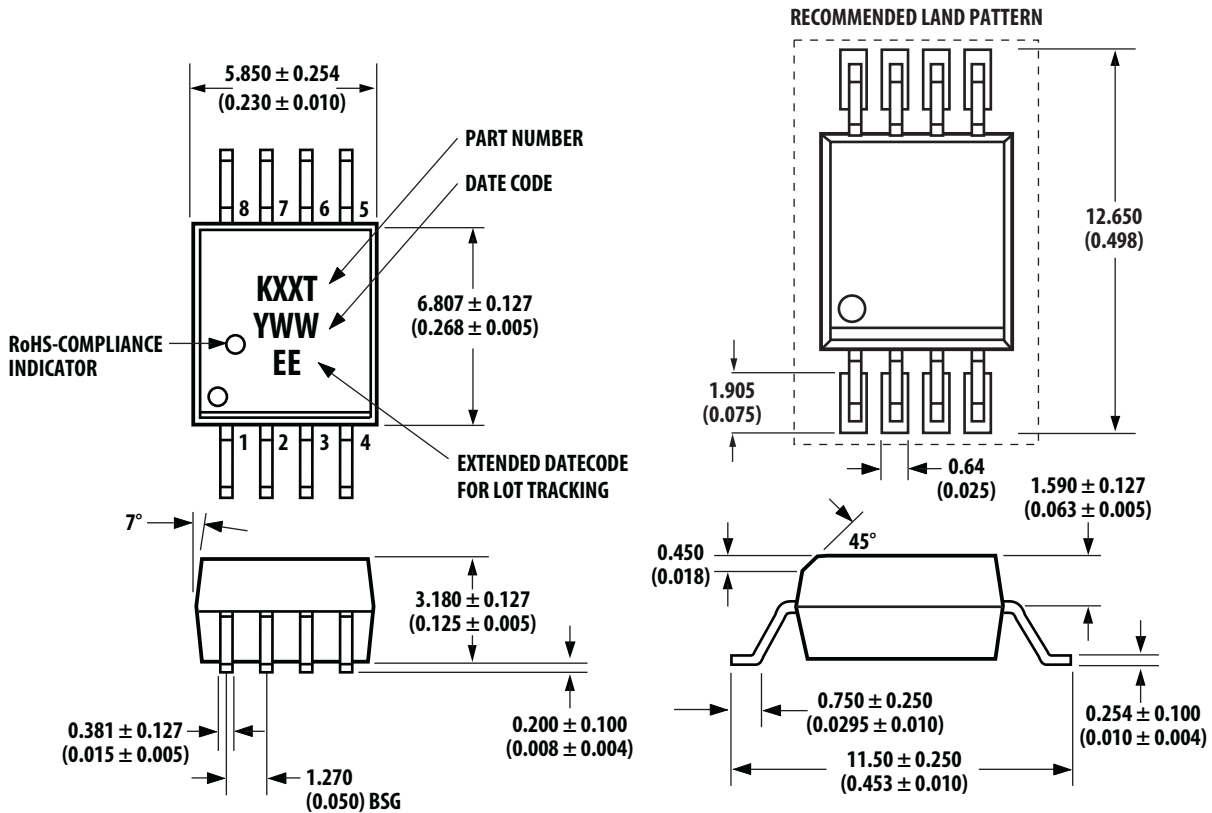

Dimensions in millimeters and (inches).

Note:
Lead coplanarity = 0.1 mm (0.004 inches).
Floating lead protrusion = 0.25mm (10mils) max.

Recommended Pb-Free IR Profile

Recommended reflow condition as per JEDEC Standard, J-STD-020 (latest revision).

Note: Non-halide flux should be used.

Regulatory Information

The ACPL-K71T, ACPL-K72T, ACPL-K74T and ACPL-K75T are approved by the following organizations:

UL

Approval under UL 1577, component recognition program up to $V_{ISO} = 5kV_{RMS}$.

CSA

Approval under CSA Component Acceptance Notice #5.

IEC/EN/DIN EN 60747-5-5

Approval under IEC/EN/DIN EN 60747-5-5.

Insulation and Safety Related Specifications

Parameter	Symbol		Units	Conditions
Minimum External Air Gap (Clearance)	L(101)	8	mm	Measured from input terminals to output terminals, shortest distance through air.
Minimum External Tracking (Creepage)	L(102)	8	mm	Measured from input terminals to output terminals, shortest distance path along body.
Minimum Internal Plastic Gap (Internal Clearance)		0.08	mm	Through insulation distance conductor to conductor, usually the straight line distance thickness between the emitter and detector.
Tracking Resistance (Comparative Tracking Index)	CTI	175	V	DIN IEC 112/VDE 0303 Part 1
Isolation Group (DIN VDE0109)		IIIa		Material Group (DIN VDE 0109)

IEC/EN/DIN EN 60747-5-5 Insulation Related Characteristic (Option 060 only)

Description	Symbol	Characteristic	Units
Installation classification per DIN VDE 0110/1.89, Table 1 for rated mains voltage ≤ 600 V rms for rated mains voltage ≤ 1000 V rms		I-IV I-III	
Climatic Classification		40/125/21	
Pollution Degree (DIN VDE 0110/1.89)		2	
Maximum Working Insulation Voltage	V_{IORM}	1140	V_{PEAK}
Input to Output Test Voltage, Method b $V_{IORM} \times 1.875 = V_{PR}$, 100% Production Test with $t_m = 1$ sec Partial Discharge < 5 pC	V_{PR}	2137	V_{PEAK}
Input to Output Test Voltage, Method a $V_{IORM} \times 1.6 = V_{PR}$, Type and sample test, $t_m = 10$ sec, Partial Discharge < 5 pC	V_{PR}	1824	V_{PEAK}
Highest Allowable Overvoltage (Transient Overvoltage, $t_{ini} = 60$ sec)	V_{IOTM}	8000	V_{PEAK}
Safety Limiting Values (Maximum values allowed in the event of a failure)			
Case Temperature	T_S	175	$^{\circ}\text{C}$
Input Current	$I_{S,INPUT}$	230	mA
Output Power	$P_{S,OUTPUT}$	600	mW
Insulation Resistance at $T_S, V_{IO} = 500$ V	R_S	10^9	Ω

Absolute Maximum Ratings

Parameter	Symbol	Min.	Max.	Units	Test Conditions
Storage Temperature	T_S	-55	130	°C	
Ambient Operating Temperature	T_A	-40	125	°C	
Supply Voltages	V_{DD}	0	6.5	V	
Output Voltage	V_O	-0.5	$V_{DD} + 0.5$	V	
Average Forward Input Current	I_F		20.0	mA	
Peak Transient Input Current	$I_{F(TRAN)}$		1	A	$\leq 1\mu s$ Pulse Width, 300pps
			80	mA	$\leq 1\mu s$ Pulse Width, <10% Duty Cycle
Reverse Input Voltage	V_r		5	V	
Input Power Dissipation	P_I		40	mW	
Output Power Dissipation	P_o		30	mW	
Lead Solder Temperature		260°C for 10 sec., 1.6 mm below seating plane			
Solder Reflow Temperature Profile		See Solder Reflow Temperature Profile Section			

Recommended Operating Conditions

Parameter	Symbol	Min.	Max.	Units	Note
Supply Voltage	V_{CC}	3.0	5.5	V	
Operating Temperature	T_A	-40	125	°C	
Forward Input Current	$I_{F(ON)}$	4	15	mA	
Forward Off State Voltage	$V_{F(OFF)}$		0.8	V	
Input Threshold Current	I_{TH}		3.5	mA	

Electrical Specifications

Over recommended temperature $T_A = -40^\circ\text{C}$ to 125°C , $3.0\text{ V} \leq V_{DD} \leq 5.5\text{ V}$. All typical specifications are at $T_A = 25^\circ\text{C}$, $V_{DD} = 5\text{ V}$.

Parameter	Symbol	Min.	Typ.	Max.	Units	Test Conditions	Fig	Notes
LED Forward Voltage	V_F	1.45	1.5	1.75	V	$I_F = 10\text{ mA}$, $T_A = 25^\circ\text{C}$		
		1.25	1.5	1.85	V	$I_F = 10\text{ mA}$		
Vf Temperature Coefficient			-1.5		mV/°C			
Input Capacitance	C_{IN}		90		pF			
Input Reverse Breakdown Voltage	BV_R	5.0			V	$I_R = 10\mu\text{A}$		
Logic High Output Voltage	V_{OH}	$V_{DD} - 0.6$			V	$I_{OH} = -3.2\text{ mA}$	4	
Logic Low Output Voltage	V_{OL}			0.6	V	$I_{OL} = 4\text{ mA}$	3	
Logic Low Output Supply Current (per channel)	I_{DDL}		0.9	1.5	mA			
Logic High Output Supply Current (per channel)	I_{DDH}		0.9	1.5	mA			

ACPL-K71T, ACPL-K74T High Speed Mode Switching Specifications

Over recommended temperature $T_A = -40^{\circ}\text{C}$ to 125°C , $4.5\text{ V} \leq V_{DD} \leq 5.5\text{ V}$. All typical specifications are at $T_A=25^{\circ}\text{C}$, $V_{DD}=5\text{ V}$.

Parameter	Symbol	Min.	Typ.	Max.	Units	Test Conditions	Fig	Notes
Propagation Delay Time to Logic Low Output	t_{PHL}		25	35	ns	$V_{IN} = 4.5\text{V}-5.5\text{V}$, $R_{IN} = 390\Omega \pm 5\%$, $C_{IN} = 100\text{pF}$, $C_L = 15\text{pF}$ $V_{THL} = 0.8\text{V}$ $V_{TLH} = 80\%$ of V_{DD}	5,6,11	1,2,3
Propagation Delay Time to Logic High Output	t_{PLH}		25	35	ns			
Pulse Width Distortion	PWD		0	12	ns			
Propagation Delay Skew	t_{PSK}			15	ns			
Output Rise Time (10% – 90%)	t_R		10		ns			
Output Fall Time (90% - 10%)	t_F		10		ns			
Common Mode Transient Immunity at Logic High Output	$ CM_H $	15	25		kV/ μs	$V_{IN} = 0\text{V}$, $R_{IN} = 390\Omega \pm 5\%$, $C_{IN} = 100\text{pF}$, $V_{CM} = 1000\text{V}$, $T_A = 25^{\circ}\text{C}$	12	4
Common Mode Transient Immunity at Logic High Output	$ CM_L $	15	25		kV/ μs	$V_{IN} = 4.5\text{V}-5.5\text{V}$, $R_{IN} = 390\Omega \pm 5\%$, $C_{IN} = 100\text{pF}$, $V_{CM} = 1000\text{V}$, $T_A = 25^{\circ}\text{C}$	12	5

ACPL-K72T, ACPL-K75T Low Power Mode Switching Specifications

Over recommended temperature $T_A = -40^{\circ}\text{C}$ to 125°C , $3.0\text{ V} \leq V_{DD} \leq 5.5\text{ V}$. All typical specifications are at $T_A=25^{\circ}\text{C}$, $V_{DD}=5\text{ V}$.

Parameter	Symbol	Min.	Typ.	Max.	Units	Test Conditions	Fig	Notes
Propagation Delay Time to Logic Low Output	t_{PHL}		60	100	ns	$I_F = 4\text{mA}$, $C_L = 15\text{pF}$ $V_{THL} = 0.8\text{V}$ $V_{TLH} = 80\%$ of V_{DD}	7, 8, 9, 10, 13	1,2,3
Propagation Delay Time to Logic High Output	t_{PLH}		35	100	ns			
Pulse Width Distortion	PWD		25	50	ns			
Propagation Delay Skew	t_{PSK}			60	ns			
Output Rise Time (10% – 90%)	t_R		10		ns			
Output Fall Time (90% - 10%)	t_F		10		ns			
Common Mode Transient Immunity at Logic High Output	$ CM_H $	25	40		kV/ μs	LED Driving Circuit Fig 13, $V_{IN} = 0\text{V}$, $R_1 = 350\Omega \pm 5\%$, $R_2 = 350\Omega \pm 5\%$, $V_{CM} = 1000\text{V}$, $T_A = 25^{\circ}\text{C}$	14	4
Common Mode Transient Immunity at Logic High Output	$ CM_L $	25	40		kV/ μs	LED Driving Circuit Fig 14, $V_{IN} = 4.5-5.5\text{V}$, $R_1 = 350\Omega \pm 5\%$, $R_2 = 350\Omega \pm 5\%$, $V_{CM} = 1000\text{V}$, $T_A = 25^{\circ}\text{C}$	14	5

Package Characteristics

All Typical at $T_A = 25^\circ\text{C}$.

Parameter	Symbol	Min.	Typ.	Max.	Units	Test Conditions	Notes
Input-Output Momentary Withstand Voltage	V_{ISO}	5000			V_{RMS}	$RH \leq 50\%$, $t = 1$ minute, $T_A = 25^\circ\text{C}$	6, 7
Input-Output Resistance	R_{I-O}		10^{14}		Ω	$V_{I-O} = 500$ V dc	6
Input-Output Capacitance	C_{I-O}		0.6		pF	$f = 1$ MHz, $T_A = 25^\circ\text{C}$	6

Notes:

- t_{PHL} propagation delay is measured from the 50% (V_{IN} or I_F) on the rising edge of the input pulse to the 0.8V of V_{DD} of the falling edge of the V_O signal. t_{PLH} propagation delay is measured from the 50% (V_{IN} or I_F) on the falling edge of the input pulse to the 80% level of the rising edge of the V_O signal.
- PWD is defined as $|t_{PHL} - t_{PLH}|$.
- t_{PSK} is equal to the magnitude of the worst case difference in t_{PHL} and/or t_{PLH} that will be seen between units at any given temperature within the recommended operating conditions.
- CM_H is the maximum tolerable rate of rise of the common mode voltage to assure that the output will remain in a high logic state.
- CM_L is the maximum tolerable rate of fall of the common mode voltage to assure that the output will remain in a low logic state.
- Device considered a two terminal device: pins 1, 2, 3 and 4 shorted together, and pins 5, 6, 7 and 8 shorted together.
- In accordance with UL 1577, each optocoupler is proof tested by applying an insulation test voltage $> 6000V_{RMS}$ for 1 second.

Performance Plots

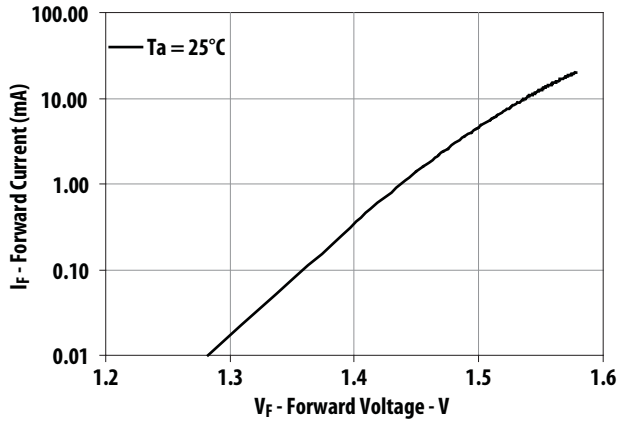

Figure 1. Typical Diode Input Forward Current Characteristic

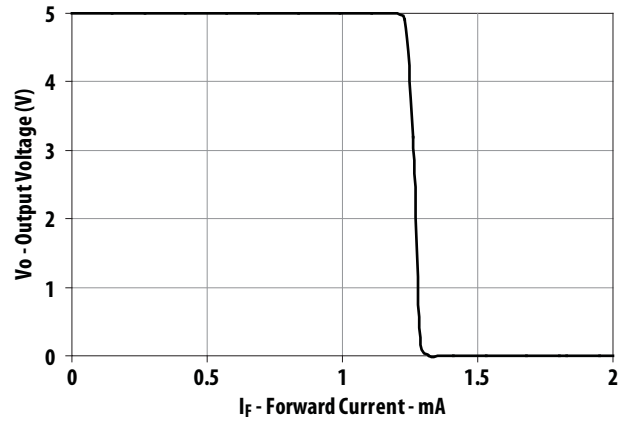

Figure 2. Typical Output Voltage vs Input Forward Current

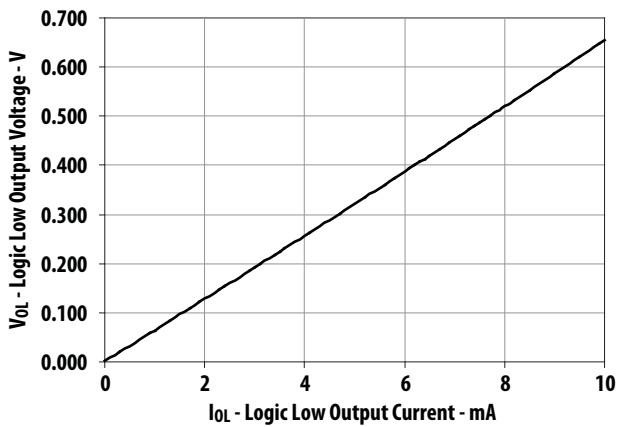

Figure 3 Typical Logic Low Output Voltage vs Low Output Current

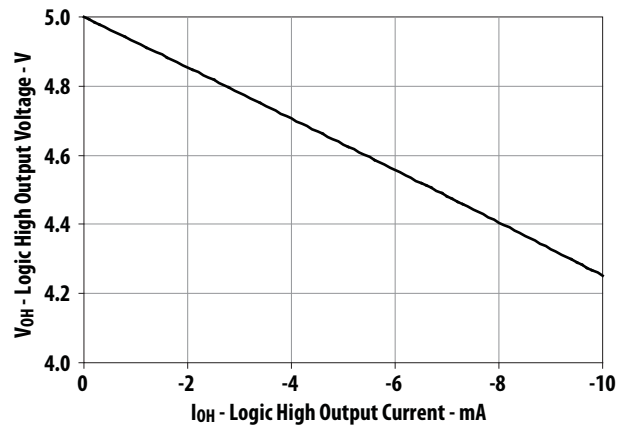

Figure 4. Typical Logic High Output Voltage vs Logic High Output Current

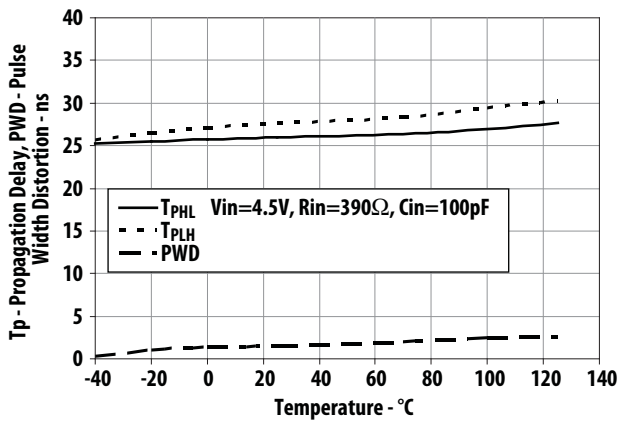

Figure 5. ACPL-K71T/K74T (High Speed) Typical Propagation Delay vs Temperature

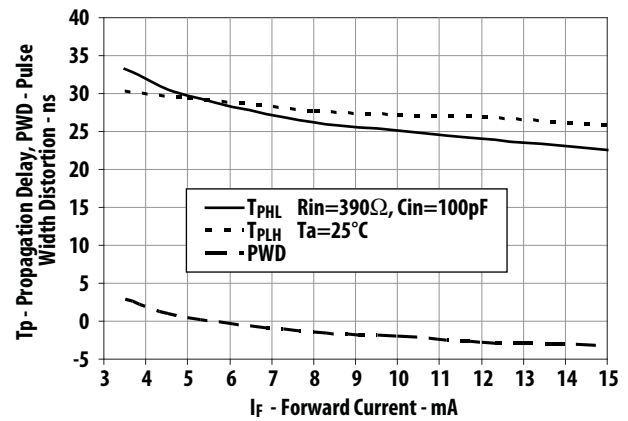

Figure 6. ACPL-K71T/K74T (High Speed) Typical Propagation Delay vs Input Forward Current

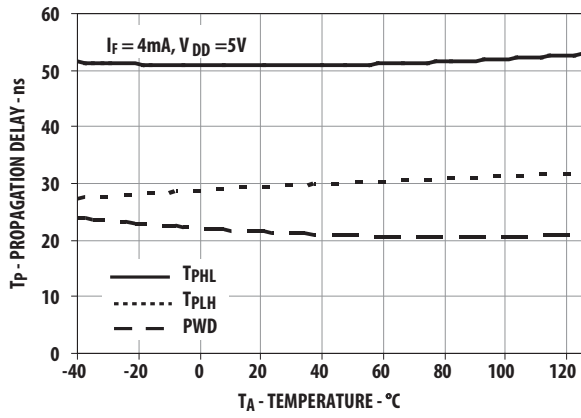

Figure 7. ACPL-K72T/K75T (5V) Typical Propagation Delay vs Temperature

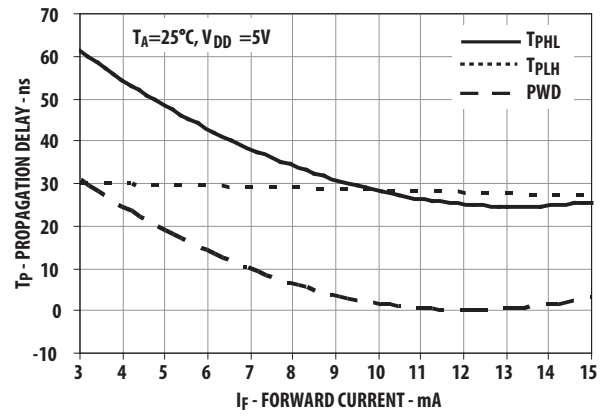

Figure 8. ACPL-K72T/K75T (5V) Typical Propagation Delay vs Input Forward Current

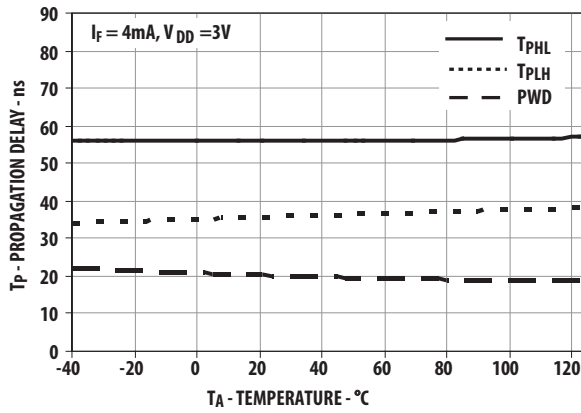

Figure 9. ACPL-K72T/K75T (3V) Typical Propagation Delay vs Temperature

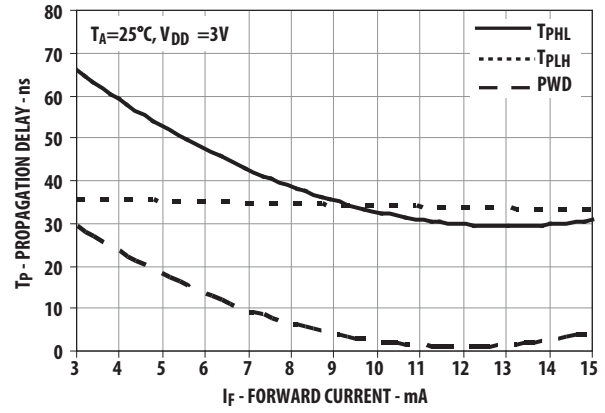

Figure 10. ACPL-K72T/K75T (3V) Typical Propagation Delay vs Input Forward Current

ACPL-K71T/K74T High Speed Mode:

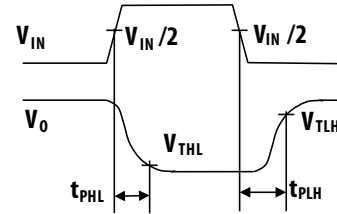
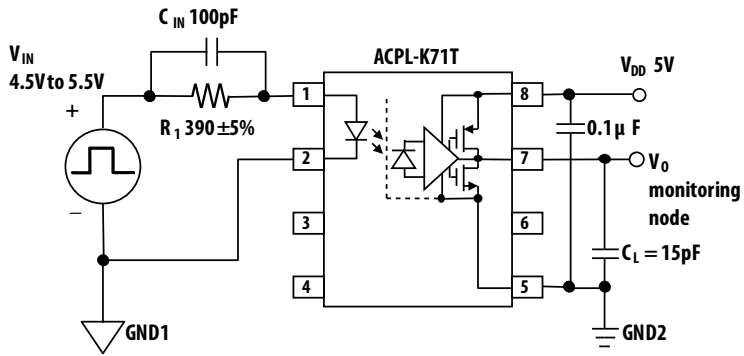

Figure 11. High Speed Mode Switching Test Circuit and Typical Waveform

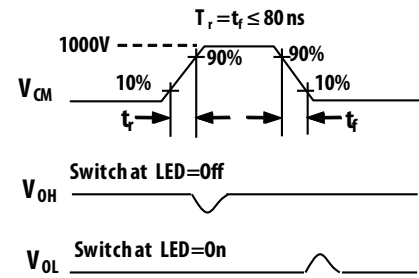
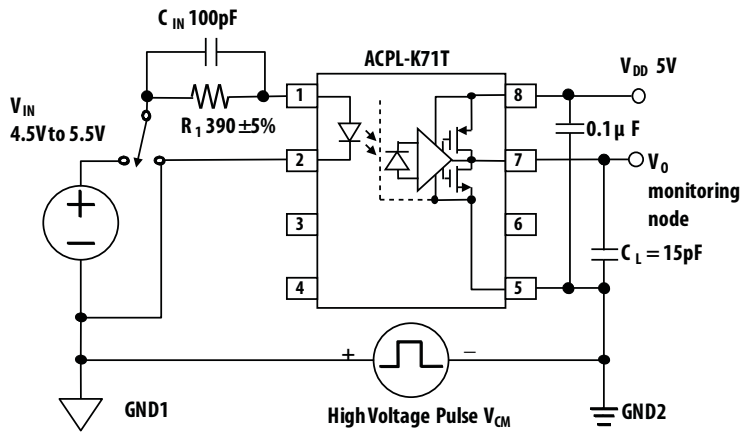

Figure 12. High Speed Mode CMR Test Circuit and Typical Waveform

ACPL-K72T/K75T Low Power Mode:

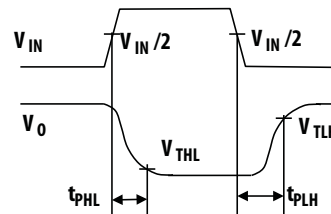
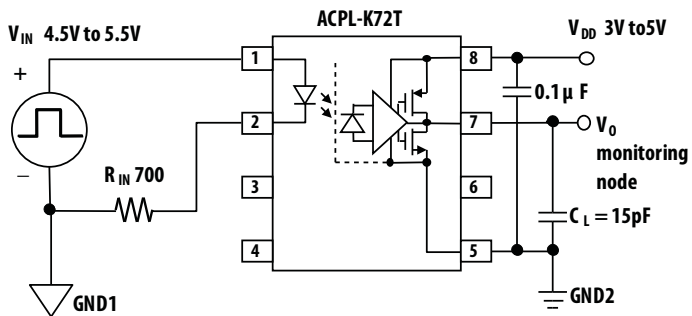

Figure 13. Low Power Mode Switching Test Circuit and Typical Waveform

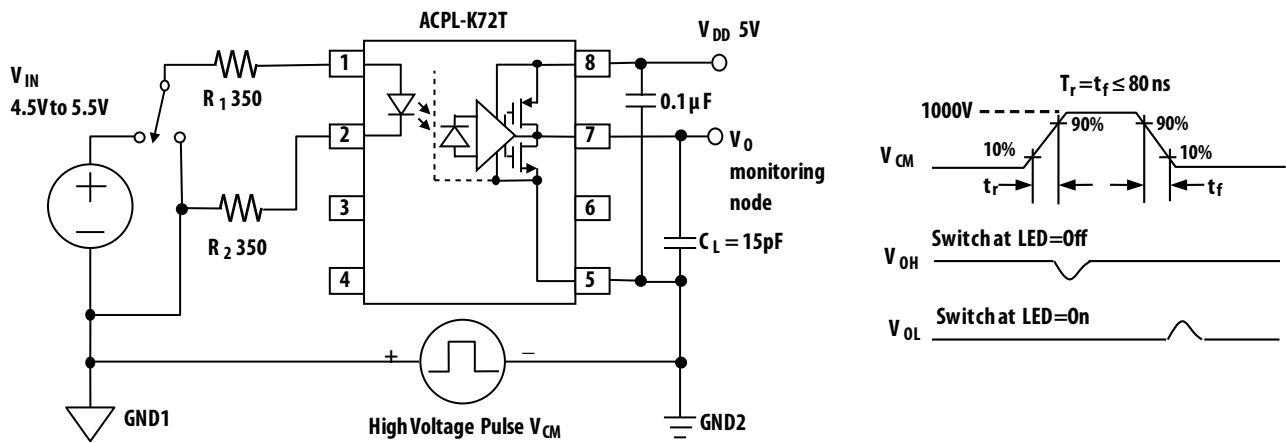
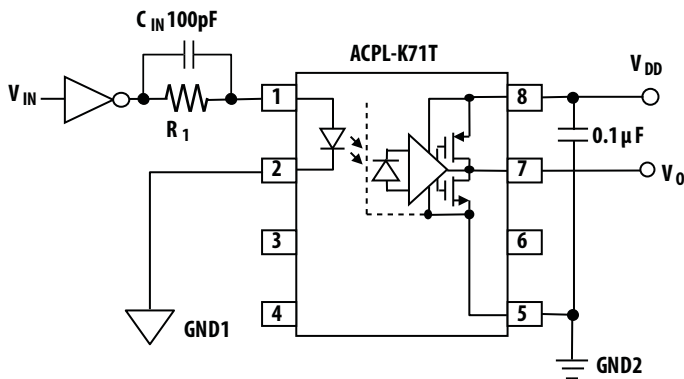

Figure 14. Low Power Mode CMR Test Circuit

Recommended Application Circuits



Truth Table

V _{IN}	LED	V _o
LOW	ON	LOW
HIGH	OFF	HIGH

Figure 15. Recommended Application Circuit for ACPL-K71T/K74T High Speed Performance

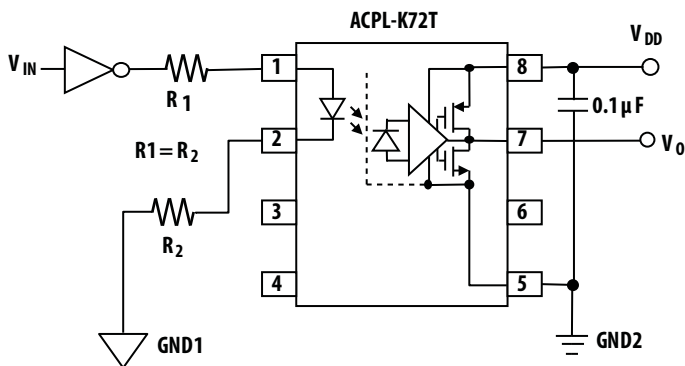

Truth Table

V _{IN}	LED	V _o
LOW	ON	LOW
HIGH	OFF	HIGH

Figure 16. Recommended Application Circuit for ACPL-K72T/K75T Low Power Performance

Thermal Resistance Model for ACPL-K71T/K72T

The diagram of ACPL-K71T/K72T for measurement is shown in Figure 17. Here, one die is heated first and the temperatures of all the dice are recorded after thermal equilibrium is reached. Then, the 2nd die is heated and all the dice temperatures are recorded. With the known ambient temperature, the die junction temperature and power dissipation, the thermal resistance can be calculated. The thermal resistance calculation can be cast in matrix form. This yields a 2 by 2 matrix for our case of two heat sources.

$$\begin{vmatrix} R_{11} & R_{12} \\ R_{21} & R_{22} \end{vmatrix} \times \begin{vmatrix} P_1 \\ P_2 \end{vmatrix} = \begin{vmatrix} \Delta T_1 \\ \Delta T_2 \end{vmatrix}$$

R_{11} : Thermal Resistance of Die1 due to heating of Die1 (°C/W)

R_{12} : Thermal Resistance of Die1 due to heating of Die2 (°C/W)

R_{21} : Thermal Resistance of Die2 due to heating of Die1 (°C/W)

R_{22} : Thermal Resistance of Die2 due to heating of Die2 (°C/W)

P_1 : Power dissipation of Die1 (W)

P_2 : Power dissipation of Die2 (W)

T_1 : Junction temperature of Die1 due to heat from all dice (°C)

T_2 : Junction temperature of Die2 due to heat from all dice (°C)

T_a : Ambient temperature (°C)

ΔT_1 : Temperature difference between Die1 junction and ambient (°C)

ΔT_2 : Temperature difference between Die2 junction and ambient (°C)

$$T_1 = (R_{11} \times P_1 + R_{12} \times P_2) + T_a$$

$$T_2 = (R_{21} \times P_1 + R_{22} \times P_2) + T_a$$

Measurement data on a low K board:

$$R_{11} = 160 \text{ °C/W}, R_{12} = R_{21} = 74 \text{ °C/W}, R_{22} = 115 \text{ °C/W}$$

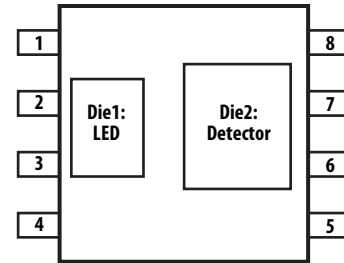

Figure 17. Diagram of ACPL-K71T/K72T for measurement

Thermal Resistance Model for ACPL-K74T/K75T

The diagram of ACPL-K74T/K75T for measurement is shown in Figure 18. Here, one die is heated first and the temperatures of all the dice are recorded after thermal equilibrium is reached. Then, the 2nd, 3rd and 4th die is heated and all the dice temperatures are recorded. With the known ambient temperature, the die junction temperature and power dissipation, the thermal resistance can be calculated. The thermal resistance calculation can be cast in matrix form. This yields a 4 by 4 matrix for our case of two heat sources.

$$\begin{vmatrix} R_{11} & R_{12} & R_{13} & R_{14} \\ R_{21} & R_{22} & R_{23} & R_{24} \\ R_{31} & R_{32} & R_{33} & R_{34} \\ R_{41} & R_{42} & R_{43} & R_{44} \end{vmatrix} \times \begin{vmatrix} P_1 \\ P_2 \\ P_3 \\ P_4 \end{vmatrix} = \begin{vmatrix} \Delta T_1 \\ \Delta T_2 \\ \Delta T_3 \\ \Delta T_4 \end{vmatrix}$$

R_{11} : Thermal Resistance of Die1 due to heating of Die1 (°C/W)

R_{12} : Thermal Resistance of Die1 due to heating of Die2 (°C/W)

R_{13} : Thermal Resistance of Die1 due to heating of Die3 (°C/W)

R_{14} : Thermal Resistance of Die1 due to heating of Die4 (°C/W)

R_{21} : Thermal Resistance of Die2 due to heating of Die1 (°C/W)

R_{22} : Thermal Resistance of Die2 due to heating of Die2 (°C/W)

R_{23} : Thermal Resistance of Die2 due to heating of Die3 (°C/W)

R_{24} : Thermal Resistance of Die2 due to heating of Die4 (°C/W)

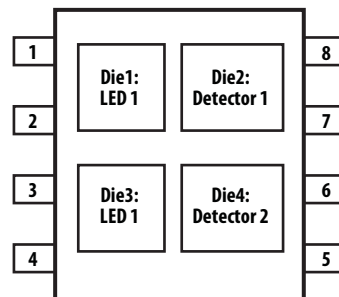

Figure 18. Diagram of ACPL-K74T/K75T for measurement

R₃₁ : Thermal Resistance of Die3 due to heating of Die1 (°C/W)
 R₃₂ : Thermal Resistance of Die3 due to heating of Die2 (°C/W)
 R₃₃ : Thermal Resistance of Die3 due to heating of Die3 (°C/W)
 R₃₄ : Thermal Resistance of Die3 due to heating of Die4 (°C/W)

R₄₁ : Thermal Resistance of Die4 due to heating of Die1 (°C/W)
 R₄₂ : Thermal Resistance of Die4 due to heating of Die2 (°C/W)
 R₄₃ : Thermal Resistance of Die4 due to heating of Die3 (°C/W)
 R₄₄ : Thermal Resistance of Die4 due to heating of Die4 (°C/W)

P₁ : Power dissipation of Die1 (W)
 P₂ : Power dissipation of Die2.
 P₃ : Power dissipation of Die3 (W)
 P₄ : Power dissipation of Die4.

T₁ : Junction temperature of Die1 due to heat from all dice (°C)
 T₂ : Junction temperature of Die2 due to heat from all dice (°C)
 T₃ : Junction temperature of Die3 due to heat from all dice (°C)
 T₄ : Junction temperature of Die4 due to heat from all dice (°C)

T_a : Ambient temperature (°C)

ΔT₁ : Temperature difference between Die1 junction and ambient (°C)
 ΔT₂ : Temperature difference between Die2 junction and ambient (°C)
 ΔT₃ : Temperature difference between Die3 junction and ambient (°C)
 ΔT₄ : Temperature difference between Die4 junction and ambient (°C)

$$T_1 = (R_{11} \times P_1 + R_{12} \times P_2 + R_{13} \times P_3 + R_{14} \times P_4) + T_a \text{ -- (1)}$$

$$T_2 = (R_{21} \times P_1 + R_{22} \times P_2 + R_{23} \times P_3 + R_{24} \times P_4) + T_a \text{ -- (2)}$$

$$T_3 = (R_{31} \times P_1 + R_{32} \times P_2 + R_{33} \times P_3 + R_{34} \times P_4) + T_a \text{ -- (3)}$$

$$T_4 = (R_{41} \times P_1 + R_{42} \times P_2 + R_{43} \times P_3 + R_{44} \times P_4) + T_a \text{ -- (4)}$$

Measurement data on a low K board:

R ₁₁	R ₁₂	R ₁₃	R ₁₄	R ₂₁	R ₂₂	R ₂₃	R ₂₄	R ₃₁	R ₃₂	R ₃₃	R ₃₄	R ₄₁	R ₄₂	R ₄₃	R ₄₄
160	76	76	76	76	115	76	76	76	76	160	76	76	76	76	115

For product information and a complete list of distributors, please go to our web site: www.avagotech.com

Avago, Avago Technologies, and the A logo are trademarks of Avago Technologies in the United States and other countries.
 Data subject to change. Copyright © 2005-2012 Avago Technologies. All rights reserved.
 AV02-3786EN - September 26, 2012



AMEYA360

Components Supply Platform

Authorized Distribution Brand :



Website :

Welcome to visit www.ameya360.com

Contact Us :

➤ Address :

401 Building No.5, JiuGe Business Center, Lane 2301, Yishan Rd
Minhang District, Shanghai , China

➤ Sales :

Direct +86 (21) 6401-6692

Email amall@ameya360.com

QQ 800077892

Skype [ameyasales1](#) [ameyasales2](#)

➤ Customer Service :

Email service@ameya360.com

➤ Partnership :

Tel +86 (21) 64016692-8333

Email mkt@ameya360.com