

TCC-103

Three-Output PTIC Control IC

Introduction

ON Semiconductor's PTIC Controller IC is a three-output high voltage digital to analog control IC specifically designed to control and bias ON Semiconductor's Passive Tunable Integrated Circuits (PTICs).

These tunable capacitive circuits are intended for use in mobile phones and dedicated RF tuning applications. The implementation of ON Semiconductor's tunable circuits in mobile phones enables significant improvement in terms of antenna radiated performance.

The tunable capacitors are controlled through a bias voltage ranging from 2 V to 20 V. The TCC-103 high-voltage PTIC control IC has been specifically designed to cover this need, providing three independent high-voltage outputs that control up to three different tunable PTICs in parallel. The device is fully controlled through a multi-protocol digital interface.

Features

- Controls ON Semiconductor's PTIC Tunable Capacitors and RF Tuners
- Compliant with Timing Needs of Cellular and Other Wireless System Requirements
- Integrated Boost Converter with 3 Programmable Outputs (Up To 24 V)
- Low Power Consumption
- Auto-detection of SPI (30- or 32-bit) or MIPI RFFE Interfaces (1.2 V or 1.8 V)
- Available in WLCSP (RDL Ball Array) and for Stand-alone or Module Integration
- These are Pb-Free Devices

Typical Applications

- Multi-band, Multi-standard, Advanced and Simple Mobile Phones
- Tunable Antenna Matching Networks
- Compatible with Closed Loop and Open-loop Antenna Tuner Applications



ON Semiconductor®

<http://onsemi.com>



**CSP16, 2.10x1.90
CASE 568AE**

MARKING DIAGRAM

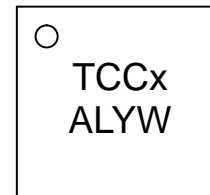

CSP16

TCC = Product Code
x = MIPI ID
A = Assembly Location
L = Wafer Lot Code
Y = Year Code
W = Week Code
O = Pin 1 Marker

ORDERING INFORMATION

See detailed ordering and shipping information in the package dimensions section on page 21 of this data sheet.

TCC-103

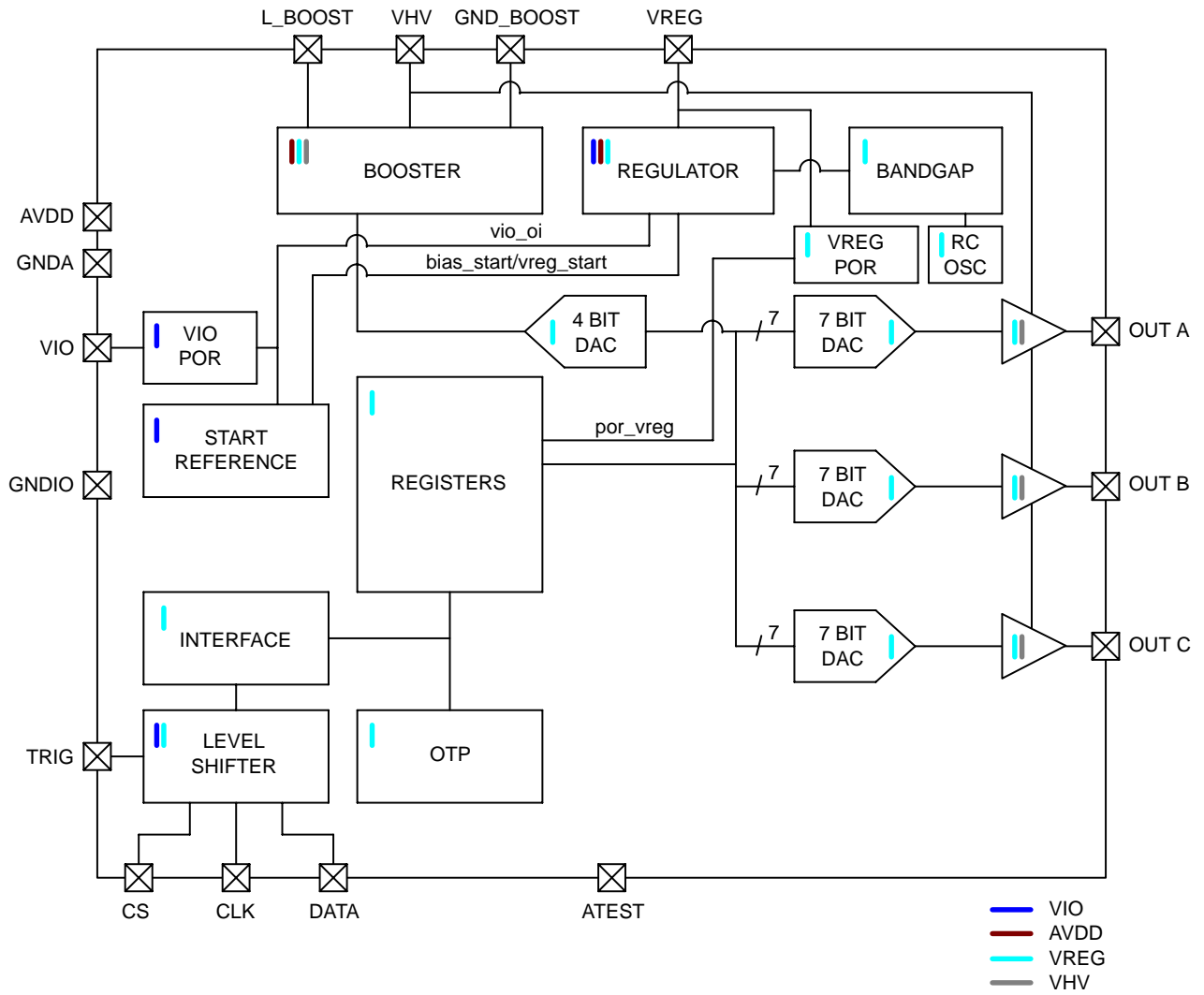

Figure 1. HV DAC Functional Block Diagram

RDL Pin Out

Table 1. PIN FUNCTION DESCRIPTIONS

Bump	Name	Type	Description
A1	VREG	Analog Output	VREG Capacitor
A2	ATEST	Analog Output	Test Pin (Ground in Application)
A3	GND_BOOST	Power	Boost Ground
A4	VHV	Analog HV I/O	Boost High Voltage Output
B1	OUTB	Analog HV Output	High Voltage Output B
B2	OUTC	Analog HV Output	High Voltage Output C
B3	AVDD	Power	Analog Supply
B4	L_BOOST	Analog HV Output	Boost Inductor
C1	OUTA	Analog HV Output	High Voltage Output A
C2	GND_DIG	Power	Digital Ground
C3	TRIG	Digital I/O	Trigger Signal Input (Note 1)
C4	GND_REF	Power	Analog Ground
D1	VIO	Power	IO Reference Supply
D2	DATA	Digital I/O	RFFE SDATA/SPI_DATA
D3	CLK	Digital Input	RFFE SCLK/SPI CLK
D4	CS	Digital Input	SPI_CS (Ground for MIPI RFFE)

1. To be grounded when not in use.

RDL Ball Array Package Footprint

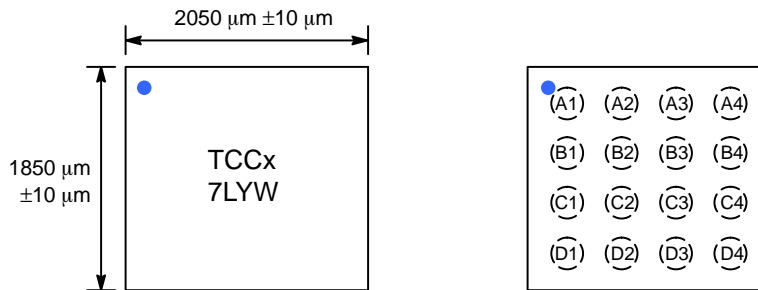

Figure 2. Ball Array Footprint – Top View

Electrical Performance Specifications

Table 2. ABSOLUTE MAXIMUM RATINGS

Symbol	Parameter	Rating	Unit
AVDD	Analog Supply Voltage	-0.3 to +6.0	V
VIO	IO Reference Supply Voltage	-0.3 to +3.6	V
V _{I/O}	Input Voltage Logic Lines (DATA, CLK, CS)	-0.3 to VIO	V
VHV	VHV Maximum Voltage	-0.3 to 30	V
V _{ESD (HBM)}	Human Body Model, JESD22-A114, All I/O	2,000	V
V _{ESD (MM)}	Machine Model, JESD22-A115	200	V
T _{STG}	Storage Temperature	-55 to +150	°C
T _{AMB_OP_MAX}	Max Operating Ambient Temperature without Damage	+110	°C

Stresses exceeding Maximum Ratings may damage the device. Maximum Ratings are stress ratings only. Functional operation above the Recommended Operating Conditions is not implied. Extended exposure to stresses above the Recommended Operating Conditions may affect device reliability.

Table 3. RECOMMENDED OPERATING CONDITIONS

Symbol	Parameter	Rating			Unit
		Min	Typ	Max	
T _{AMB_OP}	Operating Ambient Temperature	-30	-	+85	°C
T _{J_OP}	Operating Junction Temperature	-30	-	+125	°C
AVDD	Analog Supply Voltage	2.3	-	5.5	V
VIO	IO Reference Supply Voltage	1.1	-	3.0	V

Table 4. DC CHARACTERISTICS

(T_A = -30 to +85°C; V_{OUTX} = 15 V for each output; 2.3 V < AVDD < 5.5 V; 1.1 V < VIO < 3.0 V; R_{LOAD} = equivalent series load of 5.6 kΩ and 2.7 nF; C_{HV} = 22 nF; L_{BOOST} = 15 μH; TRIG pin grounded; unless otherwise specified)

Symbol	Parameter	Min	Typ	Max	Unit	Comment
Shutdown Mode						
I _{AVDD}	AVDD Supply Current	-	-	0.8	μA	VIO Supply is Low
I _{L_BOOST}	L_BOOST Leakage	-	-	1	μA	VIO Supply is Low
I _{BATT}	Battery Current	-	-	1	μA	VIO Supply is Low
I _{VIO}	VIO Supply Current	-1	-	1	μA	VIO Supply is Low
I _{CLK}	CLK Leakage	-1	-	1	μA	VIO Supply is Low
I _{DATA}	DATA Leakage	-1	-	1	μA	VIO Supply is Low

Active Mode

I _{BATT}	Average Battery Current, 3 Outputs Actively Switching 16 V for 1205 μs to 2 V for 1705 μs to 8V for 1705 μs	-	980	1,290	μA	At VHV = 20 V AVDD = 3.3 V
I _{BATT_SS0}	Average Battery Current, 3 Outputs @ 0 V Steady State	-	590	830	μA	At VHV = 20 V AVDD = 3.3 V
I _{BATT_SS2}	Average Battery Current, 3 Outputs @ 2 V Steady State	-	610	860	μA	At VHV = 20 V AVDD = 3.3 V
I _{BATT_SS16}	Average Battery Current, 3 Outputs @ 20 V Steady State	-	780	1,020	μA	At VHV = 20 V AVDD = 3.3 V
I _{L_BOOST}	Average Inductor Current, 3 Outputs Actively Switching 20 V for 1205 μs to 2 V for 1705 μs to 8 V for 1705 μs	-	730	1,000	μA	At VHV = 20 V AVDD = 3.3 V
I _{L_BOOST_SS0}	Average Inductor Current, 3 Outputs @ 0 V Steady State	-	350	550	μA	At VHV = 20 V AVDD = 3.3 V
I _{L_BOOST_SS2}	Average Inductor Current, 3 Outputs @ 2 V Steady State	-	380	570	μA	At VHV = 20 V AVDD = 3.3 V

TCC-103

Table 4. DC CHARACTERISTICS (continued)

($T_A = -30$ to $+85^\circ\text{C}$; $V_{OUTX} = 15$ V for each output; 2.3 V < AVDD < 5.5 V; 1.1 V < VIO < 3.0 V; $R_{LOAD} =$ equivalent series load of 5.6 k Ω and 2.7 nF; $C_{HV} = 22$ nF; $L_{BOOST} = 15$ μH ; TRIG pin grounded; unless otherwise specified)

Symbol	Parameter	Min	Typ	Max	Unit	Comment
Active Mode (continued)						
$I_{L_BOOST_SS16}$	Average Inductor Current, 3 Outputs @ 20 V Steady State	–	550	750	μA	At VHV = 20 V AVDD = 3.3 V
I_{VIO_INACT}	VIO Average Inactive Current	–	–	3	μA	VIO is High, No Bus Activity
I_{VIO_ACTIVE}	VIO Average Active Current	–	–	250	μA	VIO = 1.8 V, Master Sending Data at 26 MHz
V_{VREG}		2.05	–	2.3	V	No External Load Allowed

Low Power Mode

I_{AVDD}	AVDD Supply Current	–	–	7	μA	
I_{L_BOOST}	L_BOOST Leakage	–	–	3	μA	
I_{BATT}	Battery Current	–	–	10	μA	$I_{AVDD} + I_{L_BOOST}$
I_{VIO}	VIO Supply Current	–	–	3	μA	No Bus Activity
V_{VREG}		2.0	–	3.3	V	No External Load Allowed

Table 5. BOOST CONVERTER CHARACTERISTICS

(AVDD from 2.3 V to 5.5 V; VIO from 1.1 V to 3.0 V; $T_A = -30$ to $+85^\circ\text{C}$; $C_{HV} = 22$ nF; $L_{BOOST} = 15$ μH ; unless otherwise specified)

Symbol	Parameter	Conditions	Min	Typ	Max	Unit
VHV_min	Minimum Programmable Output Voltage (Average), DAC Boost = 0h	Active Mode	–	9	–	V
VHV_max	Maximum Programmable Output Voltage (Average), DAC Boost = Fh	Active Mode		24		V
Resolution	Boost Voltage Resolution	4-bit DAC	–	1	–	V
$R_{DS(ON)}$	n-Channel MOSFET On-Resistance	$I_{L_BOOST} = 10$ mA	–	1.3	–	Ω
$I_{L_BOOST_LIMIT}$	Inductor Current Limit		–	100	–	mA

TCC-103

Table 6. ANALOG OUTPUTS (OUT A, OUT B, OUT C)

(AVDD from 2.3 V to 5.5 V; VIO from 1.1 V to 3.0 V; VHV = 24 V; $T_A = -30$ to $+85^\circ\text{C}$; $R_{LOAD} = \infty$ unless otherwise specified)

Parameter	Description	Min	Typ	Max	Unit	Comment
Shutdown Mode						
Z _{OUT}	OUT A, OUT B, OUT C Output Impedance	7	–	–	MΩ	DAC Disabled
Active Mode						
V _{OH}	Maximum Output Voltage	22.0	–	–	V	DAC A, B or C = FFh, DAC Boost = Fh, I _{OH} < 10 μA
V _{OL}	Minimum Output Voltage	–	–	1	V	DAC A, B or C = 01h, DAC Boost = 0h to Fh, I _{OH} < 10 μA
Slew Rate		–	6.5	10	μs	2 V to 20 V Step, Measured at V _{OUT} = 15.2 V, R _{LOAD} = Equivalent Series Load of 5.6 kΩ and 2.7 nF, Turbo Enabled
R _{PD}	OUT A, OUT B, OUT C Set In Pull-Down Mode	–	–	800	Ω	DAC A, B or C = 00h, DAC Boost = 0h to Fh, Selected Output(s) is Disabled
Resolution	Voltage Resolution (1-bit)	–	188	–	mV	(1 LSB = 1 Bit)
V _{OFFSET}	Zero Scale, Least Squared Best Fit	-1	–	+1	LSB	
Error		-3.0	–	+3.0	%V _{OUT}	Over 2 V – 18 V V _O Range
DNL	Differential Non-linearity Least Squared Best Fit	-0.9	–	+0.9	LSB	Over 2 V – 18 V V _O Range
INL	Integral Non-linearity Least Squared Best Fit	-1	–	+1	LSB	Over 2 V – 18 V V _O Range
I _{SC}	Over Current Protection	–	35	65	mA	Any DAC Output to Ground
V _{RIPPLE}	Output Ripple with All Outputs at Steady State	–	–	10	mV RMS	Over 2 V – 18 V V _O Range, VHV = 20 V

Theory of Operation

Overview

The control IC outputs are directly controlled by programming the three DACs (DAC A, DAC B, and DAC C) through the digital interface. The DACs are 8-bit DACs used in a 7-bit format.

The DAC stages are driven from a reference voltage, generating an analog output voltage driving a high-voltage amplifier supplied from the boost converter (see Control IC block diagram – Figure 1).

The control IC output voltages are scaled from 0 to 24 V, with 128 steps of 188 mV ($2 \times 24 \text{ V} / 255 = 0.188235 \text{ V}$). The nominal control IC output can be approximated to $188 \text{ mV} \times (\text{DAC value})$.

For performance optimization the boost output voltage (VHV) can be programmed to levels between 9 V and 24 V via the DAC_boost register (4 bits with 1 V steps). The startup default level for the boosted voltage is $\text{VHV} = 20 \text{ V}$.

For proper operation and to avoid saturation of the output devices and noise issues it is recommended to operate the boosted VHV voltage at least 2 V above the highest programmed V_{OUT} voltage of any of the three outputs.

When the DAC output value is set to 00h the corresponding output is disabled and the output is pulled to GND through an effective impedance of less than 800 Ω .

Operating Modes

The following operating modes are available:

1. **Shutdown Mode:** All circuit blocks are off, the DAC outputs are disabled and placed in high Z state and current consumption is limited to minimal leakage current. The shutdown mode is entered upon initial application of AVDD or upon VIO being placed in the low state. The contents of the registers are not maintained in shutdown mode.
2. **Startup Mode:** Startup is only a transitory mode. Startup mode is entered upon a VIO high state. In startup mode all registers are reset to their default states, the digital interface is functional, the boost converter is activated, outputs OUT A, OUT B, and OUT C are disabled and the DAC outputs are placed in a high Z state. Control software can request a full hardware and register reset of the TCC-103 by sending an appropriate PWR_MODE command to direct the chip from either the active mode or the low power mode to the startup mode. From the startup mode the device automatically proceeds to the Active mode.
3. **Active Mode:** All blocks of the TCC-103 are activated and the DAC outputs are fully controlled

through the digital interface. The DAC settings can be dynamically modified and the HV outputs will be adjusted according to the specified timing diagrams. Each DAC can be individually controlled and/or switched off according to application requirements. Active mode is automatically entered from the startup mode. Active mode can also be entered from the low power mode under control software command.

4. **Low Power Mode:** In low power mode the serial interface is enabled, the DAC outputs are disabled and are placed in a high Z state and the boost voltage circuit is disabled. Control software can request to enter the low power mode from the active mode by sending an appropriate PWR_MODE command. The contents of all registers are maintained in the low power mode.

AVDD Power-On Reset

Upon application of AVDD the TCC-103 will be in shutdown mode. All circuit blocks are off and the chip draws only minimal leakage current.

VIO Power-On Reset and Startup Conditions

A high level on VIO places the chip in startup mode which provides a power on reset (POR) to the TCC-103. POR resets all registers to their default settings as described in Table 7. VIO POR also resets the serial interface circuitry. POR is **not** a brown-out detector and VIO needs to be brought back to a low level to enable the POR to trigger again.

Table 7. VIO POWER-ON RESET AND STARTUP

Register	Default State for VIO POR	Comment
DAC Boost	[1011]	VHV = 20 V
Power Mode	[01] > [00]	Transitions from SHUTDOWN to STARTUP and then Automatically to ACTIVE Mode
DAC Enable	[000]	V_{OUT} A, B and C Disabled
DAC A		Output in High-Z Mode
DAC B		Output in High-Z Mode
DAC C		Output in High-Z Mode

VIO Shutdown

A low level at any time on VIO places the chip in shutdown mode in which all circuit blocks are off. The contents of the registers are not maintained in shutdown mode.

Table 8. VIO THRESHOLDS

(AVDD from 2.3 V to 5.5 V; $T_A = -30$ to $+85^\circ\text{C}$ unless otherwise specified)

Parameter	Description	Min	Typ	Max	Unit	Comment
VIORST	VIO Low Threshold	-	-	0.2	V	When VIO is lowered below this threshold level the chip is reset and placed into the Shutdown mode.

Power Supply Sequencing

The AVDD input is typically directly supplied from the battery and thus is the first on. After AVDD is applied and before VIO is applied to the chip all circuits are in the

shutdown state and draw minimum leakage currents. Upon application of VIO the chip automatically starts up using default settings and is placed in the active state waiting for a command via the serial interface.

Table 9. TIMING

(AVDD from 2.3 V to 5.5 V; VIO from 1.1 V to 3.0 V; $T_A = -30$ to $+85^\circ\text{C}$; OUT A, OUT B & OUT C; CHV = 22 nF; $L_{\text{BOOST}} = 15 \mu\text{H}$; VHV = 20 V; Turbo-Charge mode off unless otherwise specified)

Parameter	Description	Min	Typ	Max	Unit	Comment
$T_{\text{POR_VREG}}$	Internal bias settling time from Shutdown to Active mode	-	50	120	μs	For Info Only
$T_{\text{BOOST_START}}$	Time to charge CHV @ 95% of set VHV	-	130	-	μs	For Info Only
$T_{\text{SD_TO_ACT}}$	Startup time from Shutdown to Active mode	-	180	250	μs	
$T_{\text{SET+}}$	Output A, B, C positive settling time to within 5% of the delta voltage, equivalent series load of 5.6 k Ω and 2.7 nF, V_{OUT} from 2 V to 20 V; 0Bh (11d) to 55h (85d)	-	50	60	μs	Voltage Settling Time Connected on V_{OUT} A, B, C
$T_{\text{SET-}}$	Output A, B, C negative settling time to within 5% of the delta voltage, equivalent series load of 5.6 k Ω and 2.7 nF, V_{OUT} from 20 V to 2 V; 55h (85d) to 0Bh (11d)	-	50	60	μs	Voltage Settling Time Connected on V_{OUT} A, B, C

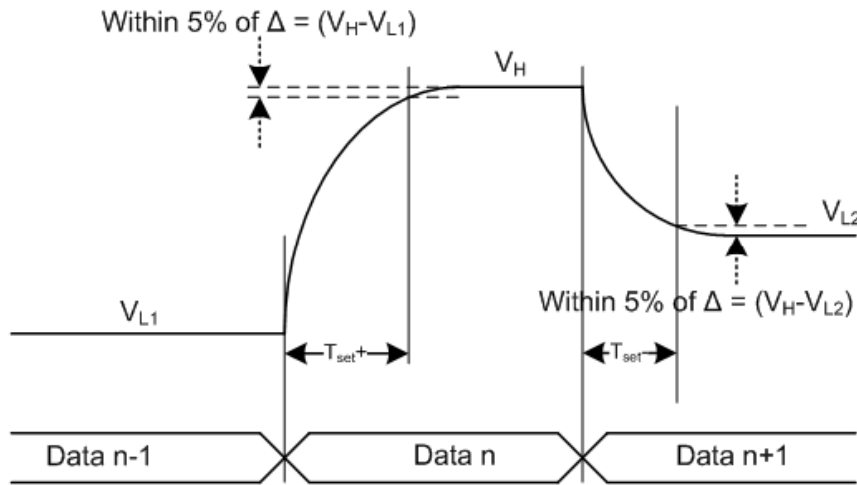

Figure 3. Output Setting Diagram

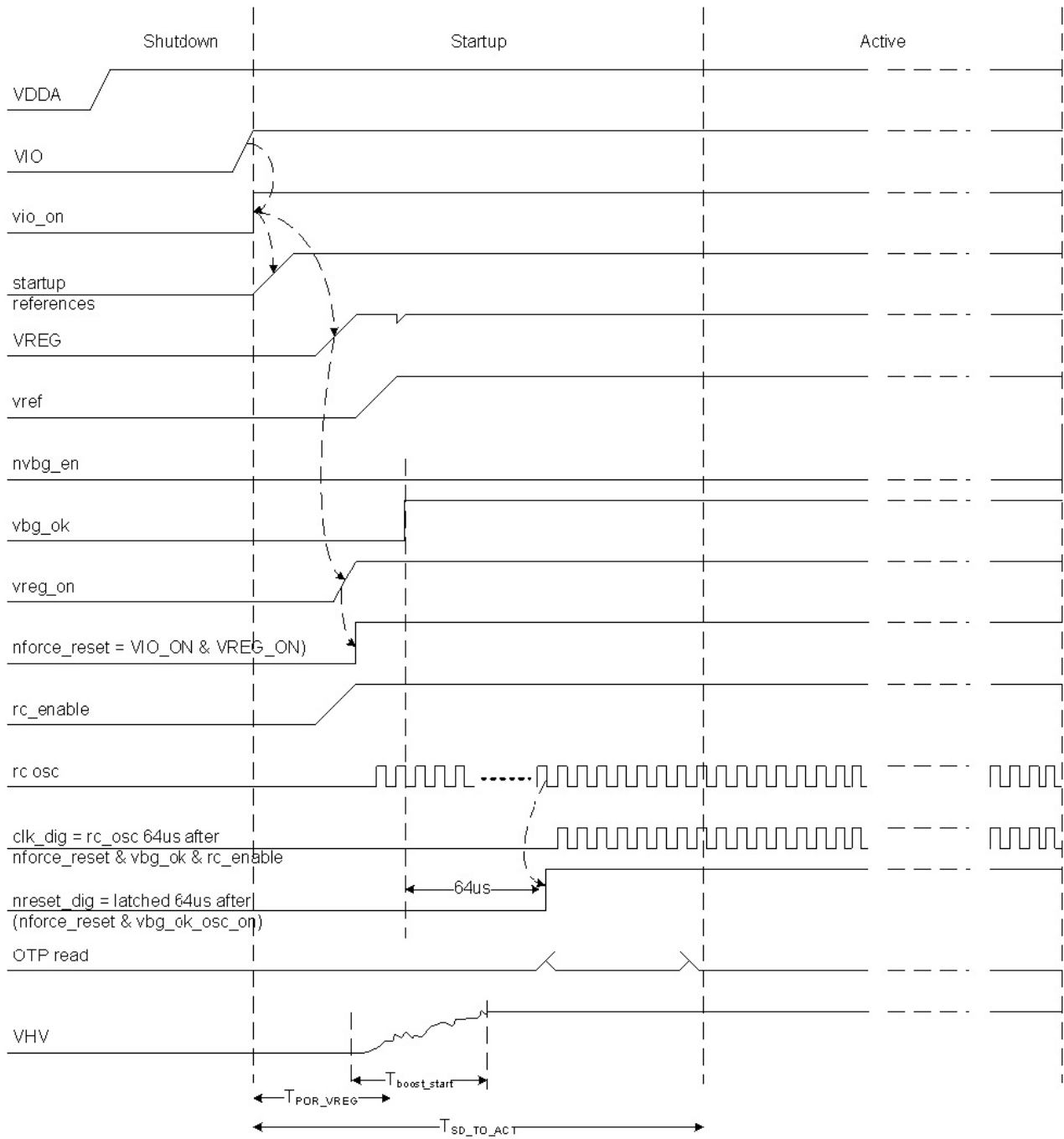

Figure 4. Startup Timing Diagram

Boost Control

The TCC-103 integrates an asynchronous current control boost converter. It operates in a discontinuous mode and features spread-spectrum circuitry for Electro-Magnetic Interference (EMI) reduction. The average boost clock is 2 MHz and the clock is spread between 0.8 MHz and 3.2 MHz.

Boost Output Voltage (VHV) Control Principle

The asynchronous control starts the boost converter as soon as the VHV voltage drops below the reference set by the 4-bit DAC and stops the boost converter when the VHV voltage rises above the reference again.

Due to the slow response time of the control loop, the VHV voltage may drop below the set voltage before the control loop compensates for it. In the same manner, VHV can rise higher than the set value. This effect may reduce the maximum output voltage available. Please refer to Figure 5 below.

The asynchronous control reduces switching losses and improves the output (VHV) regulation of the DC/DC converter under light load, particularly in the situation where the TCC-103 only maintains the output voltages to fixed values.

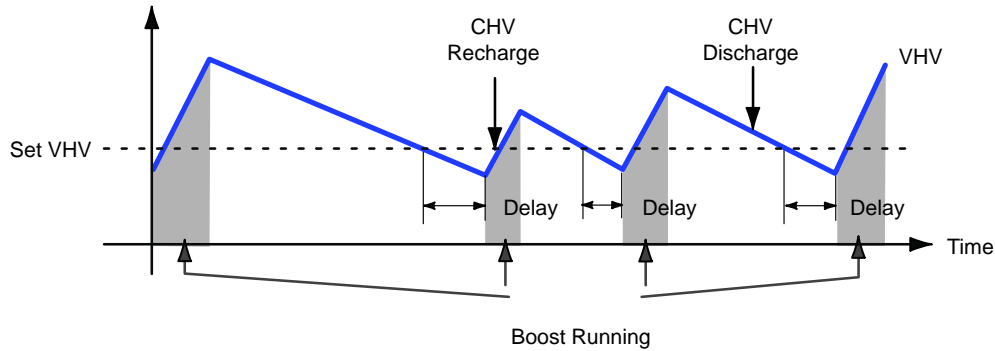

Figure 5. VHV Voltage Waveform

High Impedance (High Z) Feature

In Shutdown mode the OUT pins are set to a high impedance mode (high Z).

Following is the principle of operation for the control IC:

1. The output voltage V_{OUT} is defined by:

$$V_{OUT} = \frac{DAC\ code}{255} \times 24\ V \times 2 \quad (eq. 1)$$

2. The voltage VHV defines the maximum supply voltage of the output regulator and is set by the 4-bit DAC.
3. The maximum DC output voltage V_{OUT} is limited to $(VHV - 2\ V)$.
4. The minimum output voltage V_{OUT} is 1.0 V MAX.

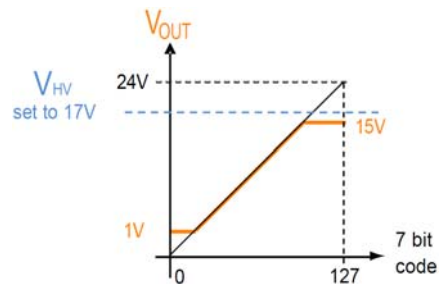

Figure 6. DAC Output Range Example A

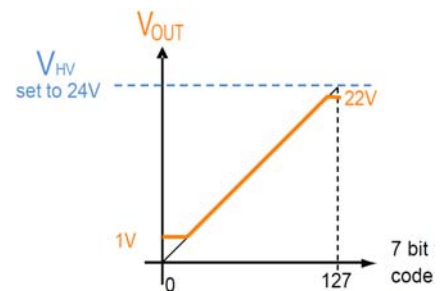

Figure 7. DAC Output Range Example B

Digital Interface

The control IC is fully controlled through a digital interface (DATA, CLK, CS). The digital interface automatically detects and responds to MIPI RFFE interface commands, 3-wire 30-bit Serial Interface commands or 3-wire 32-bit Serial Interface commands. Auto-detection is accomplished on a frame by frame basis. The digital interface is further described in the next sections of this document.

3-wire Serial Interface

The 3-wire serial interface operates in a synchronous write-only 3-wire slave mode. 30-bit or 32-bit message length is automatically detected for each frame. If CS changes state before all bits are received then all data bits are ignored. Data is transmitted most significant bit first and DATA is latched on the rising edge of CLK. Commands are latched on the falling edge of CS.

Table 10. 3-WIRE SERIAL INTERFACE SPECIFICATION

($T_A = -30$ to $+85^\circ\text{C}$; $2.3\text{ V} < \text{AVDD} < 5.5\text{ V}$; $1.1\text{ V} < \text{VIO} < 3.0\text{ V}$; unless otherwise specified)

Parameter	Description	Min	Typ	Max	Unit	Comment
F _{CLK}	Clock Frequency	–	–	26	MHz	
T _{CLK}	Clock Period	38.4	–	–	ns	
N _{BIT}	Bits Number	–	30/32	–	bits	Auto-detection 30-bit or 32-bit
T _{HIGH}	Clock High Time	13	–	–	ns	
T _{LOW}	Clock Low Time	13	–	–	ns	
T _{CSSETUP}	CS Set-up Time	5	–	–	ns	70% Rising Edge of CS to 30% Rising Edge of First Clock Cycle
T _{CSHOLD}	CS Hold Time	5	–	–	ns	30% Falling Edge of Last Clock Cycle to 70% Falling Edge of CS
T _{DSETUP}	Data Set-up Time	4	–	–	ns	Relative to 30% of CLK Rising Edge
T _{DHOLD}	Data Hold Time	4	–	–	ns	Relative to 70% of CLK Rising Edge
T _{SUCC}	CS Low Time between Successive Writes	38.4	–	–	ns	70% Falling Edge of CS to 70% Rising Edge of CS
T _{SUCC}	CS Low Time between Successive DAC Update Writes	1,500	–	–	ns	Time between Groups of DAC Update Reg [00000] & [00001] Writes
C _{CLK}	Input Capacitance	–	–	5	pF	CLK Pin
C _{DATA}	Input Capacitance	–	–	8.3	pF	DATA Pin
C _{CS}	Input Capacitance	–	–	5	pF	CS Pin
C _{TRIG}	Input Capacitance	–	–	10	pF	TRIG Pin
V _{IH}	Input Logic Level High	$0.7 \times \text{VIO}$	–	$\text{VIO} + 0.3$	V	DATA, CLK, CS
V _{IL}	Input Logic Level Low	–0.3	–	$0.3 \times \text{VIO}$	V	DATA, CLK, CS
I _{IH_DATA}	Input Current High	–2	–	10	μA	DATA
I _{IL_DATA}	Input Current Low	–2	–	1	μA	DATA
I _{IH_CLK,CS}	Input Current High	–1	–	10	μA	CLK, CS
I _{IL_CLK,CS}	Input Current Low	–1	–	1	μA	CLK, CS
V _{TP_TRIG}	Positive Going Threshold Voltage	$0.4 \times \text{VIO}$	–	$0.7 \times \text{VIO}$	V	TRIG
V _{TN_TRIG}	Negative Going Threshold Voltage	$0.3 \times \text{VIO}$	–	$0.6 \times \text{VIO}$	V	TRIG
V _{H_TRIG}	Hysteresis Voltage ($V_{TP} - V_{TN}$)	$0.1 \times \text{VIO}$	–	$0.4 \times \text{VIO}$	V	TRIG
I _{IH_TRIG}	TRIG Input Current High	–2	–	10	μA	TRIG = $0.8 \times \text{VIO}$
I _{IL_TRIG}	TRIG Input Current Low	–2	–	1	μA	TRIG = $0.2 \times \text{VIO}$

TCC-103

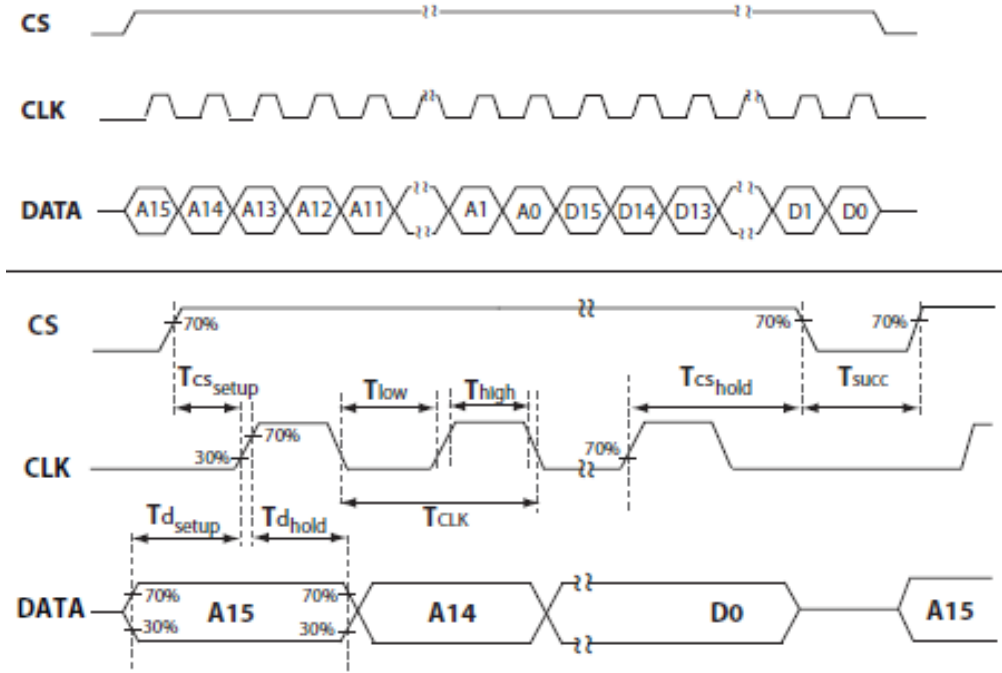

Figure 8. SPI 3-wire Serial Interface Signal Timing

SPI Frame Length Decoding

30-bit or 32-bit frame length is automatically detected. The length of the frame is defined by the number of Clock

rising edges while CS is kept high. The TCC-103 will not respond to a SPI command if the length of the frame is not exactly 30 bits or 32 bits. SPI registers are write only.

SPI Frame Structure

Table 11. 32 BITS FRAME: ADDRESS DECODING (1 OR 2 OR 3 OUTPUTS)

H0	H1	R/W	A12	A11	A10	A9	A8	A7	A6	A5	A4	A3	A2	A1	A0
1	1	0	1	0	1	0	0	1	0	0	X	X	X	X	X
ON Semiconductor Header		R/W	Device ID			Specific Device ID				Register Address for Operation					

Table 12. 30 BITS FRAME: ADDRESS DECODING (1 OR 2 OR 3 OUTPUTS)

R/W	A12	A11	A10	A9	A8	A7	A6	A5	A4	A3	A2	A1	A0
0	1	0	1	0	0	1	0	0	X	X	X	X	X
R/W	Device ID			Specific Device ID				Register Address for Operation					

Table 13. 3-WIRE SERIAL INTERFACE ADDRESS MAP

A4	A3	A2	A1	A0	Data [15:8]	Data [7:0]
0	0	0	0	0	Turbo Charge Settings for DAC A, B, C	DAC C
0	0	0	0	1	DAC B	DAC A
0	0	1	0	0	Turbo-Charge Delay Parameters for DAC A, B, C	Turbo Threshold Delay Settings for A, B, C
1	0	0	0	0	Mode Select + Control IC Setup	
1	0	0	1	0	Reserved	Reserved
To						
1	1	1	1	1		

TCC-103

Turbo-Charge Mode

The TCC-103A control IC has a Turbo-Charge mode that significantly shortens the system settling time when changing programming voltages. In Turbo-Charge mode the DAC output target voltage is temporarily set to either a delta

voltage above or a delta voltage below the actual desired target for the TCDLY time. It is recommended that VHV be set to 24 V when using Turbo-Charge mode. For more details about programming the part in Turbo-Charge mode, refer to application note XXXX (coming soon).

RF Front-End Control Interface (MIPI RFFE Interface)

The TCC-103 is a write-only slave device which is fully compliant to the MIPI Alliance Specification for RF Front-End Control Interface (RFFE) Version

1.10.00 26 July 2011. This device is rated at Full-Speed operation for $1.65\text{ V} < \text{VIO} < 1.95\text{ V}$ and at Half-Speed operation for $1.1\text{ V} < \text{VIO} < 1.65\text{ V}$. When using the MIPI RFFE interface the CS pin is grounded.

Table 14. MIPI RFFE INTERFACE SPECIFICATION

($T_A = -30$ to $+85^\circ\text{C}$; $2.3\text{ V} < \text{AVDD} < 5.5\text{ V}$; $1.1\text{ V} < \text{VIO} < 1.95\text{ V}$; unless otherwise specified)

Parameter	Description	Min	Typ	Max	Unit	Comment
F _{SCLK}	Clock Full-Speed Frequency	0.032	–	26	MHz	Full-Speed Operation: 1.65 V < VIO < 1.95 V
T _{SCLK}	Clock Full-Speed Period	0.038	–	32	μs	Full-Speed Operation: 1.65 V < VIO < 1.95 V
T _{SCLKIH}	CLK Input High Time	11.25	–	–	ns	Full-Speed
T _{SCLKIL}	CLK Input Low Time	11.25	–	–	ns	Full-Speed
F _{SCLK_HALF}	Clock Half-Speed Frequency	0.032	–	13	MHz	
T _{SCLK_HALF}	Clock Half-Speed Period	0.077	–	32	μs	
T _{SCLKIH}	CLK Input High Time	24	–	–	ns	Half-Speed
T _{SCLKIL}	CLK Input Low Time	24	–	–	ns	Half-Speed
V _{TP}	Positive Going Threshold Voltage	$0.4 \times \text{VIO}$	–	$0.7 \times \text{VIO}$	V	CLK, DATA, TRIG, 1.2 or 1.8 V Bus
V _{TN}	Negative Going Threshold Voltage	$0.3 \times \text{VIO}$	–	$0.6 \times \text{VIO}$	V	CLK, DATA, TRIG, 1.2 or 1.8 V Bus
V _H	Hysteresis Voltage (V _{TP} – V _{TN})	$0.1 \times \text{VIO}$	–	$0.4 \times \text{VIO}$	V	CLK, DATA, TRIG, 1.2 or 1.8 V Bus
I _{IH}	Input Current High	–2	–	+10	μA	TRIG, SDATA = $0.8 \times \text{VIO}$
		–1	–	+10	μA	SCLK = $0.8 \times \text{VIO}$
I _{IL}	Input Current Low	–2	–	+1	μA	TRIG, SDATA = $0.2 \times \text{VIO}$
		–1	–	+1	μA	SCLK = $0.2 \times \text{VIO}$
C _{CLK}	Input Capacitance	–	–	5	pF	CLK Pin
C _{DATA}	Input Capacitance	–	–	8.3	pF	DATA Pin
C _{TRIG}	Input Capacitance	–	–	10	pF	TRIG Pin
TD _{SETUP}	DATA Setup Time	–	–	1	ns	Full-Speed
TD _{HOLD}	DATA Hold Time	–	–	5	ns	Full-Speed
TD _{SETUP}	DATA Setup Time	–	–	2	ns	Half-Speed
TD _{HOLD}	DATA Hold Time	–	–	5	ns	Half-Speed
T _{SUCC}	Time between Successive DAC Update Writes	1,500	–	–	ns	

TCC-103

The control IC contains twenty-four 8-bit registers. Register content is described in Table 15. Some additional

registers, implement as provision, are not described in this document.

Table 15. MIPI RFFE ADDRESS MAP

Register Address	Description	Purpose	Access Type	Size (Bits)
0x00	DAC Configuration (Enable Mask)	High Voltage Output Enable Mask	Write	7
0x01	Turbo Register DAC A, B & C	Turbo-Charge Configuration DAC A, B & C	Write	8
0x02	DAC A Register	Used to Set Up OUT A	Write	8
0x03	DAC B Register	Used to Set Up OUT B	Write	8
0x04	DAC C Register	Used to Set Up OUT C	Write	8
0x10	DAC Boost (VHV)	Settings for the Boost High Voltage	Write	8
0x11	Trigger Register	Trigger Configuration	Write	8
0x12	Turbo-Charge Delay DAC A, B, C	Turbo-Charge Delay Steps DAC A, B, C	Write	8
0x13	Turbo-Charge Delay DAC A, B, C	Turbo-Charge Delay Multiplication DAC A, B, C	Write	8
0x1C	Power Mode and Trigger Register	Power Mode & Trigger Control PWR_MODE [7:6] TRIG_REG [5:0]	Write	8
0x1D	Product ID Register	Product Number * Hard Coded into ASIC	(Write)	8
0x1E	Manufacturer ID Register	MN (10 Bits Long) Manufacturer ID[7:0] Hard Coded into ASIC	(Write)	8
0x1F	Unique Slave Identifier Register (USID)	Spare [7:6] [5,4] = Manufacturer ID [9:8] USID [3:0]	Write	8

*The two least significant bits are programmed in OTP during manufacture.

Command Sequences

- **Register 0 Write** (used to access the Register 0 DAC Configuration - Enable Mask). Register 0 can be also be accessed using Register Write or/and Extended Register Write.

- **Register Write** (used to access only one register at the time)
- **Extended Register Write** (used to access a group of contiguous registers with one command bursting up to 16 bytes)

Register 0 Write Command Sequence

The Command Sequence starts with a Sequence Start Condition (SSC) which is followed by the Register 0 Write

Command Frame. This Frame contains the Slave address, a logic one, and the seven bit word that will be written to Register 0. The Command Sequence is depicted below.

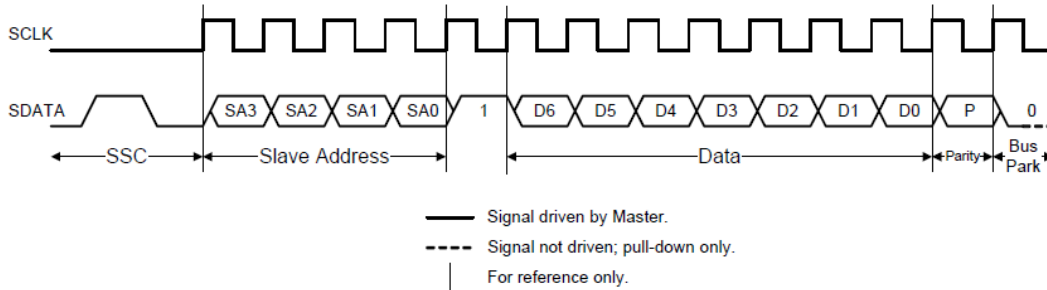

Figure 9. Register 0 Write Command Sequence

Table 16. MIPI RFFE COMMAND FRAME FOR REGISTER 0 WRITE COMMAND SEQUENCE

Description	SSC		Command Frame										BP
	1	0	SA [3,0]	1	SSE	0	0	DAC_A	DAC_B	DAC_C	0	P	
SSE & DAC Configuration	1	0	SA [3,0]	1	SSE	0	0	DAC_A	DAC_B	DAC_C	0	P	BP

Register Write Command Sequence

The Write Register command sequence may be used to access each register (addresses 0-31).

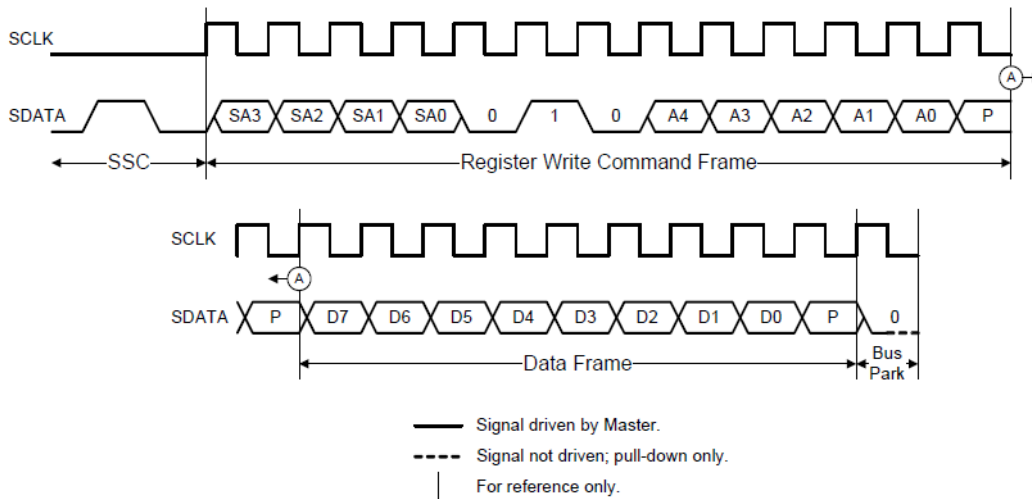

Figure 10. Register Write Command Sequence

Table 17. MIPI RFFE COMMAND FRAME FOR REGISTER 0 WRITE COMMAND SEQUENCE

Description	SSC		Command Frame										Data Frame		BP
	1	0	SA [3,0]	0	1	0	0	0	0	0	1	P	Turbo Charge [7:0]	P	
Turbo Charge Settings	1	0	SA [3,0]	0	1	0	0	0	0	0	1	P	Turbo Charge [7:0]	P	BP
Register Write DAC A	1	0	SA [3,0]	0	1	0	0	0	0	1	0	P	TC [8] & DAC_A [6:0]	P	BP
Register Write DAC B	1	0	SA [3,0]	0	1	0	0	0	0	1	1	P	TC [9] & DAC_B [6:0]	P	BP
Register Write DAC C	1	0	SA [3,0]	0	1	0	0	0	1	0	0	P	TC [10] & DAC_C [6:0]	P	BP

Extended Register Write Command Sequence

In order to access more than one register in one sequence this message could be used. Most commonly it will be used for loading three DAC registers at the same time. The four LSBs of the Extended Register Write Command Frame determine the number of bytes that will be written by the Command Sequence. A value of 0b0000 would write one byte and a value of 0b1111 would write sixteen bytes.

If more than one byte is to be written, the register address in the Command Sequence contains the address of the first extended register that will be written to and the Slave's local extended register address shall be automatically incremented by one for each byte written up to address 0x1F, starting from the address indicated in the Address Frame.

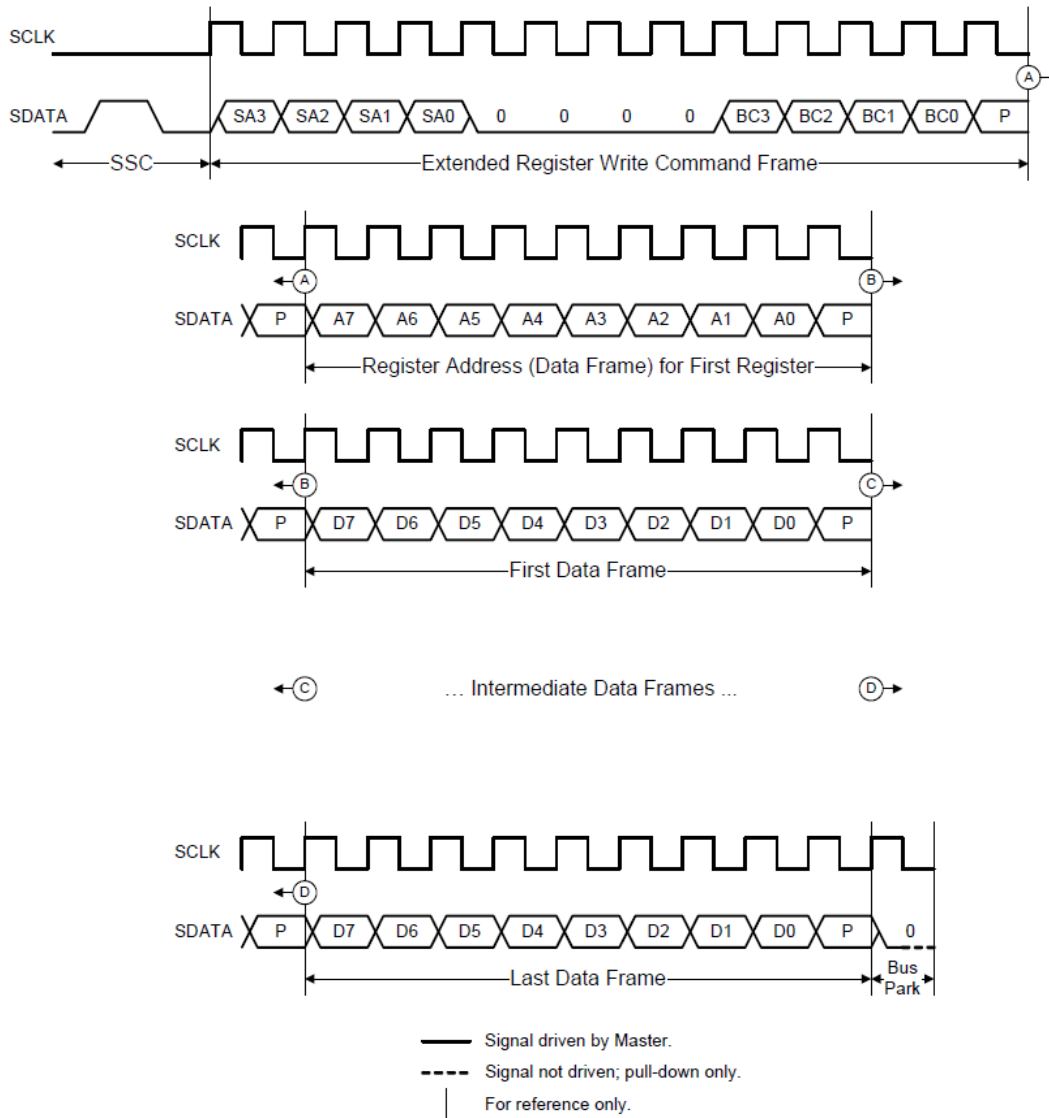

Figure 11. Extended Register Write Command Sequence

Table 18. EXTENDED REGISTER WRITE

Description	SSC		Command Frame										Address Frame														
Extended Register Write Turbo Charge & DAC	1	0	SA [3,0]				0	0	0	0	0	0	1	1	P	<Starting Address>						P					
																0	0	0	0	0	0	0	0	0	0	1	P
Data Frame		Data Frame		Data Frame		Data Frame		BP																			
<Data-8 Bit>	P	<Data-8 Bit>	P	<Data-8 Bit>	P	<Data-8 Bit>	P	<Data-8 Bit>	P	BP																	
Turbo Charge	P	DAC_A [7,0]		P	DAC_B [7,0]		P	DAC_C [7,0]		P	BP																

TCC-103

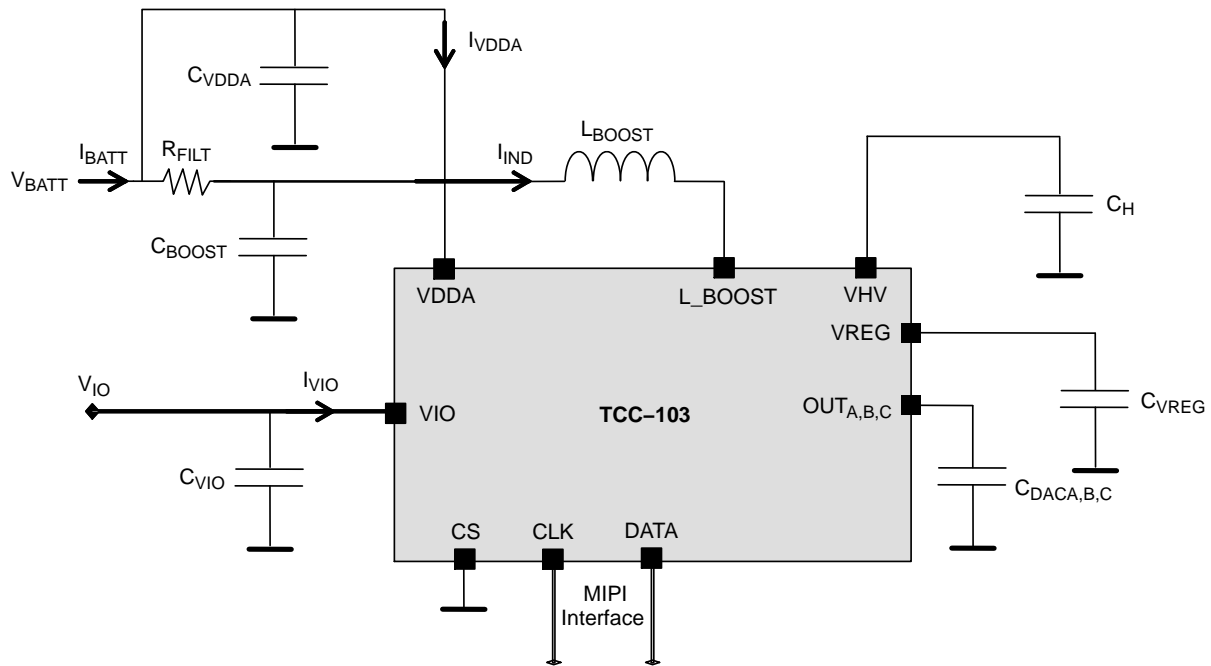

Figure 12. Recommended MIPI RFFE Interface Application Schematic

Table 19. RECOMMENDED EXTERNAL BOM

Component	Description	Nominal Value	Package (Inch)	Recommended P/N
C _{BOOST}	Boost Supply Capacitor, 10 V	1 μF	0402	TDK: C1005X5R1A105K
L _{BOOST}	Boost Inductor	15 μH	0603	Coilcraft: 0603LS-153X_L ABCO: LPS181210T-150M Others: TDK: VLS2010ET-150M Sumida: CDH20D11DLDNP-150MC
R _{FILT}	Decoupling Resistor, 5%	3.3 Ω	0402	Vishay: CRCW04023R30JNED
C _{VIO}	V _{IO} Supply Decoupling, 10 V	100 nF	0201	Murata: GRM033R61A104ME15D
C _{AVDD}	V _{AVDD} Supply Decoupling, 10 V	1 μF	0402	TDK: C1005X5R1A105K
C _{VREG}	V _{VREG} Supply Decoupling, 10 V	220 nF	0201	TDK: C0603X5R1A224M
C _{HV}	Boost Output Capacitor, 50 V	22 nF	0402	Murata: GRM155R71H223KA12
C _{dacA} C _{dacB} C _{dacC}	Decoupling Capacitor, 50 V	100 pF	0201	Murata: GRM0335C1H101JD01D

TAPE & REEL DIMENSIONS

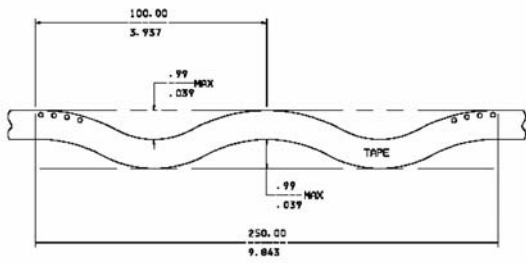

FIGURE 1
CHAMBER (TOP VIEW)
ALLOWABLE CAMBER TO BE 1MM/100MM NON-ACCUMULATIVE OVER 250MM

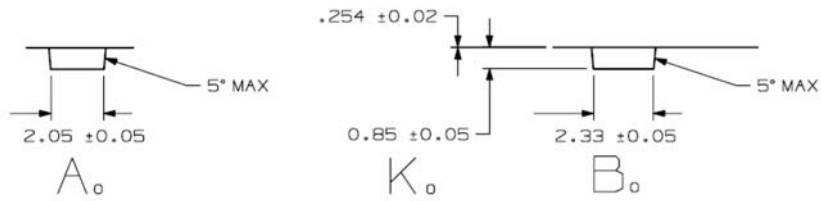
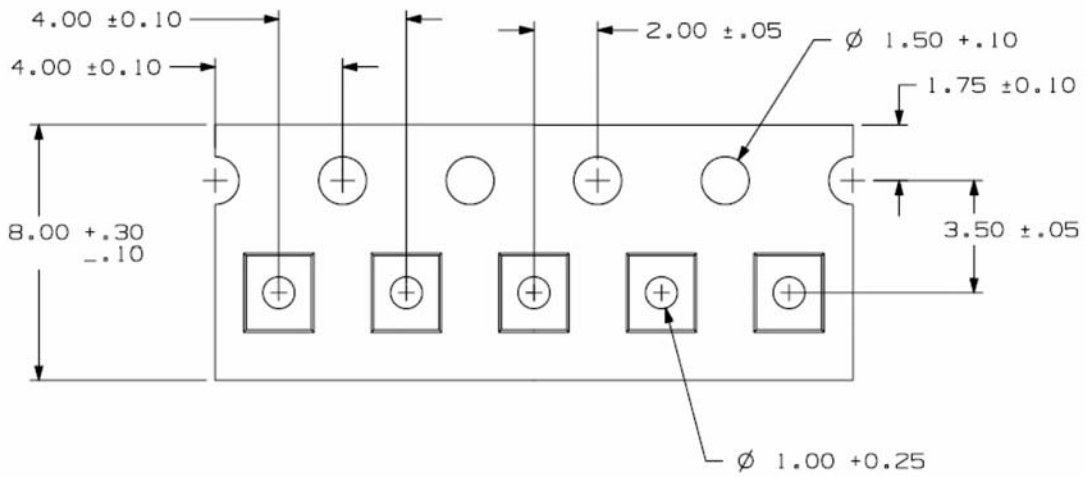
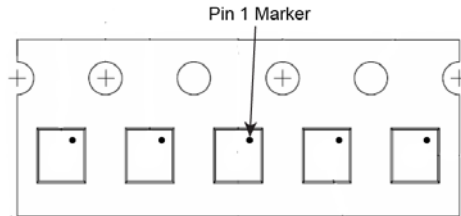
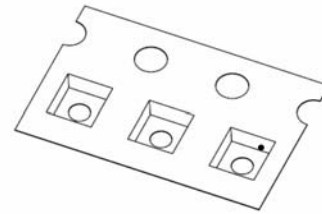

Figure 14. WLCSP Carrier Tape Drawings

TCC-103

Table 20. ORDERING INFORMATION

Device	Package	Shipping†
TCC-103A-RT	RDL (Pb-Free)	3000 / Tape & Reel
TCC-103B-RT	RDL (Pb-Free)	3000 / Tape & Reel
TCC-103C-RT	RDL (Pb-Free)	3000 / Tape & Reel
TCC-103D-RT	RDL (Pb-Free)	3000 / Tape & Reel

†For information on tape and reel specifications, including part orientation and tape sizes, please refer to our Tape and Reel Packaging Specifications Brochure, BRD8011/D.

TCC-103

PACKAGE DIMENSIONS

CSP16, 2.1x1.90
CASE 568AE
ISSUE O

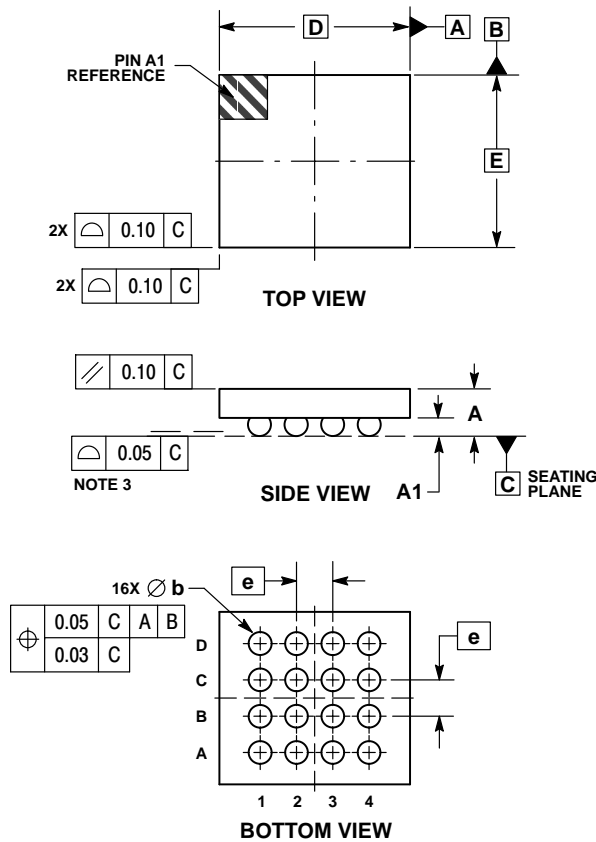

NOTES:

1. DIMENSIONING AND TOLERANCING PER ASME Y14.5M, 1994.
2. CONTROLLING DIMENSION: MILLIMETERS.
3. COPLANARITY APPLIES TO SPHERICAL CROWNS OF SOLDER BALLS.

DIM	MILLIMETERS	
	MIN	MAX
A	---	0.62
A1	0.18	0.22
b	0.24	0.30
D	2.10 BSC	
E	1.90 BSC	
e	0.40 BSC	

RECOMMENDED SOLDERING FOOTPRINT*

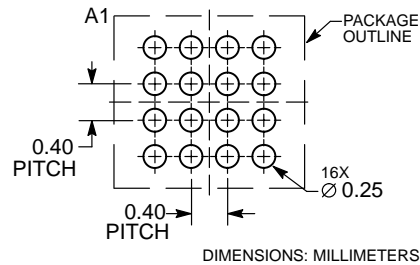

*For additional information on our Pb-Free strategy and soldering details, please download the ON Semiconductor Soldering and Mounting Techniques Reference Manual, SOLDERRM/D.

ON Semiconductor and are registered trademarks of Semiconductor Components Industries, LLC (SCILLC). SCILLC owns the rights to a number of patents, trademarks, copyrights, trade secrets, and other intellectual property. A listing of SCILLC's product/patent coverage may be accessed at www.onsemi.com/site/pdf/Patent-Marking.pdf. SCILLC reserves the right to make changes without further notice to any products herein. SCILLC makes no warranty, representation or guarantee regarding the suitability of its products for any particular purpose, nor does SCILLC assume any liability arising out of the application or use of any product or circuit, and specifically disclaims any and all liability, including without limitation special, consequential or incidental damages. "Typical" parameters which may be provided in SCILLC data sheets and/or specifications can and do vary in different applications and actual performance may vary over time. All operating parameters, including "Typicals" must be validated for each customer application by customer's technical experts. SCILLC does not convey any license under its patent rights nor the rights of others. SCILLC products are not designed, intended, or authorized for use as components in systems intended for surgical implant into the body, or other applications intended to support or sustain life, or for any other application in which the failure of the SCILLC product could create a situation where personal injury or death may occur. Should Buyer purchase or use SCILLC products for any such unintended or unauthorized application, Buyer shall indemnify and hold SCILLC and its officers, employees, subsidiaries, affiliates, and distributors harmless against all claims, costs, damages, and expenses, and reasonable attorney fees arising out of, directly or indirectly, any claim of personal injury or death associated with such unintended or unauthorized use, even if such claim alleges that SCILLC was negligent regarding the design or manufacture of the part. SCILLC is an Equal Opportunity/Affirmative Action Employer. This literature is subject to all applicable copyright laws and is not for resale in any manner.

PUBLICATION ORDERING INFORMATION

LITERATURE FULFILLMENT:
 Literature Distribution Center for ON Semiconductor
 P.O. Box 5163, Denver, Colorado 80217 USA
Phone: 303-675-2175 or 800-344-3860 Toll Free USA/Canada
Fax: 303-675-2176 or 800-344-3867 Toll Free USA/Canada
Email: orderlit@onsemi.com

N. American Technical Support: 800-282-9855 Toll Free
 USA/Canada
Europe, Middle East and Africa Technical Support:
 Phone: 421 33 790 2910
Japan Customer Focus Center
 Phone: 81-3-5817-1050

ON Semiconductor Website: www.onsemi.com
Order Literature: <http://www.onsemi.com/orderlit>
 For additional information, please contact your local Sales Representative

AMEYA360

Components Supply Platform

Authorized Distribution Brand :



Website :

Welcome to visit www.ameya360.com

Contact Us :

➤ Address :

401 Building No.5, JiuGe Business Center, Lane 2301, Yishan Rd
Minhang District, Shanghai , China

➤ Sales :

Direct +86 (21) 6401-6692

Email amall@ameya360.com

QQ 800077892

Skype [ameyasales1](#) [ameyasales2](#)

➤ Customer Service :

Email service@ameya360.com

➤ Partnership :

Tel +86 (21) 64016692-8333

Email mkt@ameya360.com