

NEW! PAN1326/1316 SERIES **BLUETOOTH**[®] HIGH TEMPERATURE MODULES

Dual-Mode Wireless Bluetooth Connectivity and Bluetooth Low Energy

Introducing Panasonic's latest breakthrough in wireless networking, the **NEW PAN1326/1316 Series** RF Modules featuring both Bluetooth Low Energy and Bluetooth connectivity. This powerful new technology combination creates a low cost, ultra-low power wireless networking solution for short range applications.

The Bluetooth Low Energy (BLE) standard is designed to reduce power consumption by establishing very fast connections (few ms) and transferring small amounts of data. Using these techniques, energy consumption is reduced to a tenth of Classic Bluetooth. Bluetooth Low Energy devices can be put into a sleep mode and activated for event activities such as sending files to a gateway, PC or mobile phone. Furthermore, the maximum power consumption is less than 15 mA and the average power consumption is about 1 uA. Thus, a small coin cell – such as a CR2032 – is capable of powering a device for up to 10 years of operation.

The **NEW PAN1326/1316 Host Controlled Interface (HCI) Series** also brings Texas Instrument's CC2564, to an easy-to-use module format. Panasonic's tiny footprint technology offers a module of only 85.5 mm² including antenna. The modules are designed to accommodate PCBs pad pitch of 1.3mm and as little as two layers for easy implementation and manufacture.

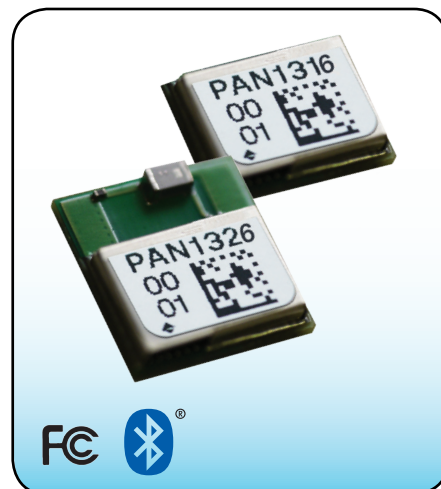

Product Performance:

- Best-in-class Bluetooth RF performance (Tx power, Rx sensitivity, blocking)
- Fully Qualified Bluetooth v4.0 EDR
- Dimensions PAN1326: 9mm x 9.5mm x 1.8mm (width x length x height)
- Dimensions PAN1316: 6.5mm x 9mm x 1.7mm (width x length x height)
- Certifications: Bluetooth, FCC, IC and CE
- Operating Temperature Range: -40°C to +85°C
- Supply Voltage Range: 1.7 - 4.8V
- Profiles: SPP, A2DP and AVRCP
- Based upon TI's CC2564
- Integrates with TI's ultra low-power MSP430 microprocessor
- Very fast algorithm for both ACL and eSCO
- Supports Extended Range Tx power with 10dBm typical output
- Low power scan method for page and inquiry scans at 1/3rd normal power

PAN1326 and PAN1316 Part Numbers:

Part Numbers	Description
ENW-89823A2KF	PAN1326, CC2564, Bluetooth & Bluetooth Low Energy, HCI module, antenna
ENW-89823C2KF	PAN1316, CC2564, Bluetooth & Bluetooth Low Energy, HCI module, no antenna

Development and Evaluation Part Numbers:

Part Numbers	Description
ENW-89825A2JF	PAN1323ETU, Development Module for PAN1315, PAN1316, PAN1317, PAN1325, PAN1326, PAN1327
EVAL_PAN1323	EVAL_PAN1323, Development Kit for PAN1315, PAN1316, PAN1317, PAN1325, PAN1326, PAN1327

Interfaces:

The PAN1326/PAN1316 Host Controlled Interface supports several transport layers with the following features:

- UART Rates of up to 4Mbps
- Three and Four Wire UART Transport

Applications:

- Sports and Fitness
 - Heart Rate Monitor
 - Blood Pressure Sensor
 - Blood Glucose Meter
 - Thermometer
- Industrial Sensors
- Toys
- Entertainment Devices
- Mobile Accessories
- All Bluetooth Wireless Applications
- Assisted Living
 - Flood Alarm
 - Heating Control
 - Automatic Key Control

Bluetooth Module Pin Compatibility:

Series	Description	Compatibility
PAN1315A	BT Classic	100% Pin Compatible
PAN1316	BT and BLE	
PAN1317	Dual Mode BT and ANT	
PAN1325A	BT Classic with antenna	100% Pin Compatible
PAN1326	BT and BLE with antenna	
PAN1327	Dual Mode BT and ANT with antenna	

All Panasonic Bluetooth RF Modules are 100% pin compatible with the next generation of Bluetooth Classic and Low Energy devices. This unique design feature enables designers to seamlessly transition between Bluetooth Classic, Low Energy and ANT enabled modules, addressing larger markets and providing migration paths to circumvent obsolescence.

Technical Specifications for PAN1326 and PAN1316:

Parameter	Value	Condition / Notes
Receiver Sensitivity (BER=10 ⁻³)	-93 dBm	GFSK, Typical, Dirty TX On
Output Power	10 dBm	VDD_In = VBAT
Power Supply	1.7 - 4.8 V	Battery or DC/DC
Ultra Low Power Scan	135 uA	1.28s Interval
GFSK DH1\DH5	33 mA	Full Throughput
Operating Temperature Range	-40°C to + 85°C	

Block Diagram PAN1326:

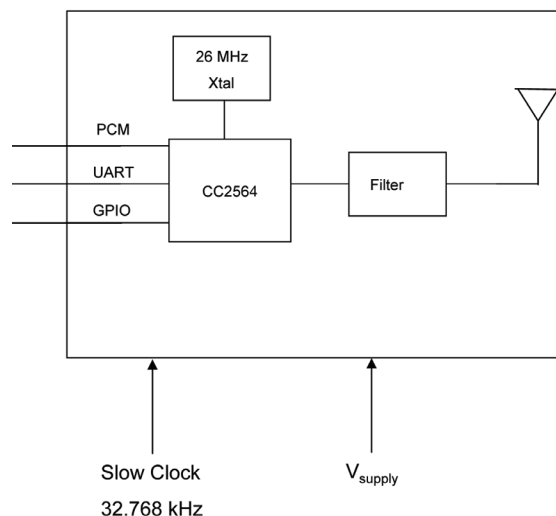

Block Diagram PAN1316:

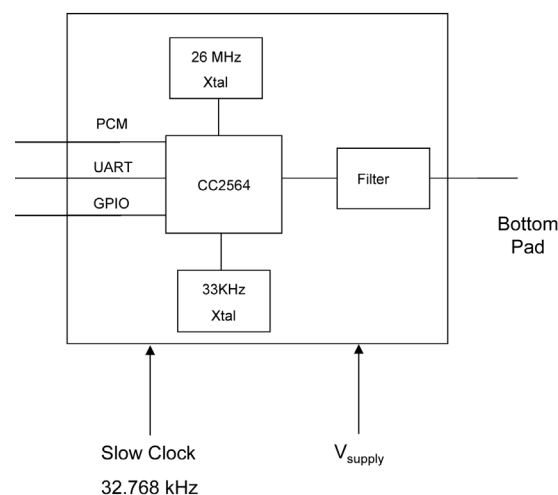

AMEYA360

Components Supply Platform

Authorized Distribution Brand :



Website :

Welcome to visit www.ameya360.com

Contact Us :

➤ Address :

401 Building No.5, JiuGe Business Center, Lane 2301, Yishan Rd
Minhang District, Shanghai , China

➤ Sales :

Direct +86 (21) 6401-6692

Email amall@ameya360.com

QQ 800077892

Skype [ameyasales1](#) [ameyasales2](#)

➤ Customer Service :

Email service@ameya360.com

➤ Partnership :

Tel +86 (21) 64016692-8333

Email mkt@ameya360.com