



128K x 36, 256K x 18
3.3V Synchronous ZBT SRAMs
3.3V I/O, Burst Counter
Pipelined Outputs

AS8C403601-QC166N
AS8C401801-QC166N

Features

- ◆ 128K x 36, 256K x 18 memory configurations
- ◆ Supports high performance system speed - 166 MHz (x18) (3.2 ns Clock-to-Data Access)
- ◆ Supports high performance system speed - 166 MHz (x36) (3.5 ns Clock-to-Data Access)
- ◆ ZBT™ Feature - No dead cycles between write and read cycles
- ◆ Internally synchronized output buffer enable eliminates the need to control \overline{OE}
- ◆ Single R/\overline{W} (READ/WRITE) control pin
- ◆ Positive clock-edge triggered address, data, and control signal registers for fully pipelined applications
- ◆ 4-word burst capability (interleaved or linear)
- ◆ Individual byte write (\overline{BW}_1 - \overline{BW}_4) control (May tie active)
- ◆ Three chip enables for simple depth expansion
- ◆ 3.3V power supply ($\pm 5\%$), 3.3V I/O Supply (VDDQ)
- ◆ Optional- Boundary Scan JTAG Interface (IEEE 1149.1 compliant)
- ◆ Packaged in a JEDEC standard 100-pin plastic thin quad flatpack (TQFP)

Description

The 403601/401801 are 3.3V high-speed 4,718,592-bit (4.5 Mega-bit) synchronous SRAMs. They are designed to eliminate dead bus cycles when turning the bus around between reads and writes, or writes and reads. Thus, they have been given the name ZBT™, or Zero Bus Turnaround.

Address and control signals are applied to the SRAM during one clock cycle, and two cycles later the associated data cycle occurs, be it read or write.

The 403601/401801 contain data I/O, address and control signal registers. Output enable is the only asynchronous signal and can be used to disable the outputs at any given time.

A Clock Enable (\overline{CEN}) pin allows operation of the 403601/401801 to be suspended as long as necessary. All synchronous inputs are ignored when (\overline{CEN}) is high and the internal device registers will hold their previous values.

There are three chip enable pins (\overline{CE}_1 , CE_2 , \overline{CE}_2) that allow the user to deselect the device when desired. If any one of these three are not asserted when ADV/\overline{LD} is low, no new memory operation can be initiated. However, any pending data transfers (reads or writes) will be completed. The data bus will tri-state two cycles after chip is deselected or a write is initiated.

Pin Description Summary

A0-A17	Address Inputs	Input	Synchronous
\overline{CE}_1 , CE_2 , \overline{CE}_2	Chip Enables	Input	Synchronous
\overline{OE}	Output Enable	Input	Asynchronous
R/\overline{W}	Read/Write Signal	Input	Synchronous
\overline{CEN}	Clock Enable	Input	Synchronous
\overline{BW}_1 , \overline{BW}_2 , \overline{BW}_3 , \overline{BW}_4	Individual Byte Write Selects	Input	Synchronous
CLK	Clock	Input	N/A
ADV/\overline{LD}	Advance burst address / Load new address	Input	Synchronous
\overline{LBO}	Linear / Interleaved Burst Order	Input	Static
TMS	Test Mode Select	Input	Synchronous
TDI	Test Data Input	Input	Synchronous
TCK	Test Clock	Input	N/A
TDO	Test Data Output	Output	Synchronous
\overline{TRST}	JTAG Reset (Optional)	Input	Asynchronous
\overline{ZZ}	Sleep Mode	Input	Synchronous
I/O0-I/O31, I/OP1-I/OP4	Data Input / Output	I/O	Synchronous
VDD, VDDQ	Core Power, I/O Power	Supply	Static
VSS	Ground	Supply	Static

5281 tbl 01

NOVEMBER 2010

Description continued

The 403601/401801 has an on-chip burst counter. In the burst mode, the 403601/401801 can provide four cycles of data for a single address presented to the SRAM. The order of the burst sequence is defined by the $\overline{\text{LBO}}$ input pin. The $\overline{\text{LBO}}$ pin selects between linear and interleaved burst sequence. The $\text{ADV}/\overline{\text{LD}}$ signal is used to load a new

external address ($\text{ADV}/\overline{\text{LD}} = \text{LOW}$) or increment the internal burst counter ($\text{ADV}/\overline{\text{LD}} = \text{HIGH}$).

The 403601/401801 SRAMs utilize Alliance's latest high-performance CMOS process and are packaged in a JEDEC standard 14mm x 20mm 100-pin thin plastic quad flatpack (TQFP)

Pin Definition⁽¹⁾

Symbol	Pin Function	I/O	Active	Description
A0-A17	Address Inputs	I	N/A	Synchronous Address inputs. The address register is triggered by a combination of the rising edge of CLK, $\text{ADV}/\overline{\text{LD}}$ low, $\overline{\text{CEN}}$ low, and true chip enables.
$\text{ADV}/\overline{\text{LD}}$	Advance / Load	I	N/A	$\text{ADV}/\overline{\text{LD}}$ is a synchronous input that is used to load the internal registers with new address and control when it is sampled low at the rising edge of clock with the chip selected. When $\text{ADV}/\overline{\text{LD}}$ is low with the chip deselected, any burst in progress is terminated. When $\text{ADV}/\overline{\text{LD}}$ is sampled high then the internal burst counter is advanced for any burst that was in progress. The external addresses are ignored when $\text{ADV}/\overline{\text{LD}}$ is sampled high.
$\overline{\text{R}}/\overline{\text{W}}$	Read / Write	I	N/A	$\overline{\text{R}}/\overline{\text{W}}$ signal is a synchronous input that identifies whether the current load cycle initiated is a Read or Write access to the memory array. The data bus activity for the current cycle takes place two clock cycles later.
$\overline{\text{CEN}}$	Clock Enable	I	LOW	Synchronous Clock Enable Input. When $\overline{\text{CEN}}$ is sampled high, all other synchronous inputs, including clock are ignored and outputs remain unchanged. The effect of $\overline{\text{CEN}}$ sampled high on the device outputs is as if the low to high clock transition did not occur. For normal operation, $\overline{\text{CEN}}$ must be sampled low at rising edge of clock.
$\overline{\text{BW}}_1\text{-}\overline{\text{BW}}_4$	Individual Byte Write Enables	I	LOW	Synchronous byte write enables. Each 9-bit byte has its own active low byte write enable. On load write cycles (When $\overline{\text{R}}/\overline{\text{W}}$ and $\text{ADV}/\overline{\text{LD}}$ are sampled low) the appropriate byte write signal ($\overline{\text{BW}}_1\text{-}\overline{\text{BW}}_4$) must be valid. The byte write signal must also be valid on each cycle of a burst write. Byte Write signals are ignored when $\overline{\text{R}}/\overline{\text{W}}$ is sampled high. The appropriate byte(s) of data are written into the device two cycles later. $\overline{\text{BW}}_1\text{-}\overline{\text{BW}}_4$ can all be tied low if always doing write to the entire 36-bit word.
$\overline{\text{CE}}_1, \overline{\text{CE}}_2$	Chip Enables	I	LOW	Synchronous active low chip enable. $\overline{\text{CE}}_1$ and $\overline{\text{CE}}_2$ are used with CE_2 to enable the 403601/401801. ($\overline{\text{CE}}_1$ or $\overline{\text{CE}}_2$ sampled high or CE_2 sampled low) and $\text{ADV}/\overline{\text{LD}}$ low at the rising edge of clock, initiates a deselect cycle. The ZBT™ has a two cycle deselect, i.e., the data bus will tri-state two clock cycles after deselect is initiated.
CE_2	Chip Enable	I	HIGH	Synchronous active high chip enable. CE_2 is used with $\overline{\text{CE}}_1$ and $\overline{\text{CE}}_2$ to enable the chip. CE_2 has inverted polarity but otherwise identical to $\overline{\text{CE}}_1$ and $\overline{\text{CE}}_2$.
CLK	Clock	I	N/A	This is the clock input to the 403601/401801. Except for $\overline{\text{OE}}$, all timing references for the device are made with respect to the rising edge of CLK.
I/O ₀ -I/O ₃₁ I/O _{P1} -I/O _{P4}	Data Input/Output	I/O	N/A	Synchronous data input/output (I/O) pins. Both the data input path and data output path are registered and triggered by the rising edge of CLK.
$\overline{\text{LBO}}$	Linear Burst Order	I	LOW	Burst order selection input. When $\overline{\text{LBO}}$ is high the Interleaved burst sequence is selected. When $\overline{\text{LBO}}$ is low the Linear burst sequence is selected. $\overline{\text{LBO}}$ is a static input and it must not change during device operation.
$\overline{\text{OE}}$	Output Enable	I	LOW	Asynchronous output enable. $\overline{\text{OE}}$ must be low to read data from the 403601/401801. When $\overline{\text{OE}}$ is high the I/O pins are in a high-impedance state. $\overline{\text{OE}}$ does not need to be actively controlled for read and write cycles. In normal operation, $\overline{\text{OE}}$ can be tied low.
TMS	Test Mode Select	I	N/A	Gives input command for TAP controller. Sampled on rising edge of TCK. This pin has an internal pullup.
TDI	Test Data Input	I	N/A	Serial input of registers placed between TDI and TDO. Sampled on rising edge of TCK. This pin has an internal pullup.
TCK	Test Clock	I	N/A	Clock input of TAP controller. Each TAP event is clocked. Test inputs are captured on rising edge of TCK, while test outputs are driven from the falling edge of TCK. This pin has an internal pullup.
TDO	Test Data Output	O	N/A	Serial output of registers placed between TDI and TDO. This output is active depending on the state of the TAP controller.
$\overline{\text{TRST}}$	JTAG Reset (Optional)	I	LOW	Optional Asynchronous JTAG reset. Can be used to reset the TAP controller, but not required. JTAG reset occurs automatically at power up and also resets using TMS and TCK per IEEE 1149.1. If not used $\overline{\text{TRST}}$ can be left floating. This pin has an internal pullup. Only available in BGA package.
ZZ	Sleep Mode	I	HIGH	Synchronous sleep mode input. ZZ HIGH will gate the CLK internally and power down the 403601/401801 to its lowest power consumption level. Data retention is guaranteed in Sleep Mode. This pin has an internal pulldown.
V _{DD}	Power Supply	N/A	N/A	3.3V core power supply.
V _{DDQ}	Power Supply	N/A	N/A	3.3V I/O Supply.
V _{SS}	Ground	N/A	N/A	Ground.

NOTE:

1. All synchronous inputs must meet specified setup and hold times with respect to CLK.

5261 6/1 02

Functional Block Diagram

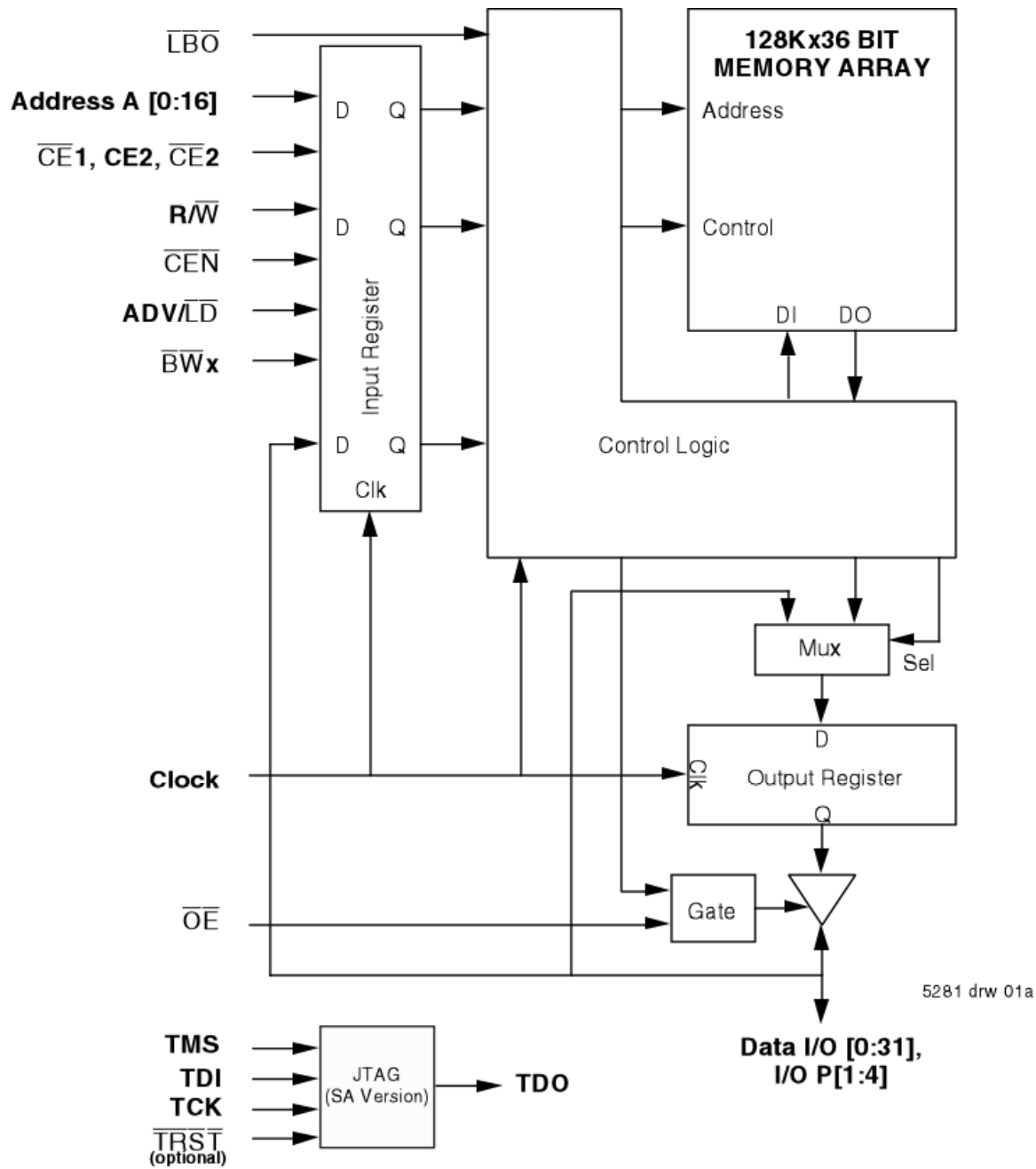

Functional Block Diagram

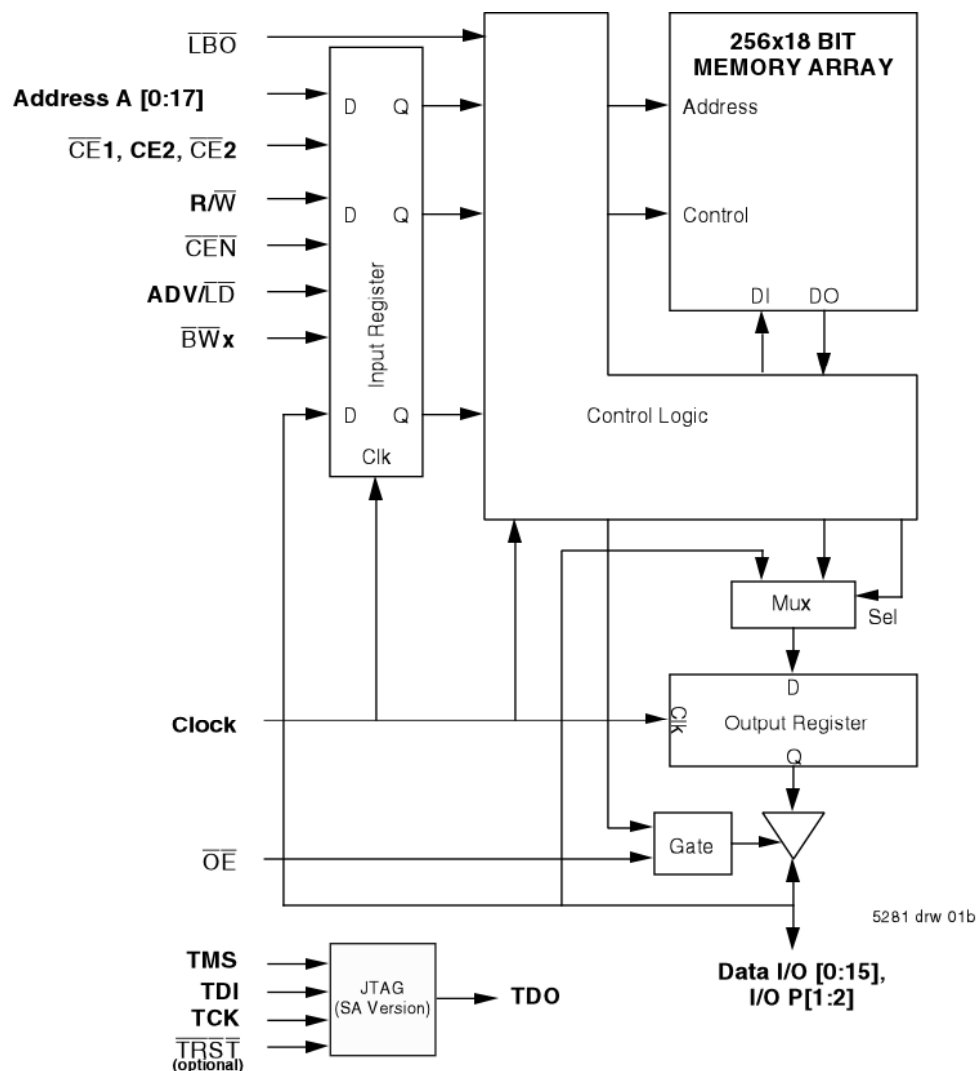

Recommended DC Operating Conditions

Symbol	Parameter	Min.	Typ.	Max.	Unit
V _{DD}	Core Supply Voltage	3.135	3.3	3.465	V
V _{DDQ}	I/O Supply Voltage	3.135	3.3	3.465	V
V _{SS}	Supply Voltage	0	0	0	V
V _{IH}	Input High Voltage - Inputs	2.0	—	V _{DD} + 0.3	V
V _{IH}	Input High Voltage - I/O	2.0	—	V _{DDQ} + 0.3 ⁽²⁾	V
V _{IL}	Input Low Voltage	-0.3 ⁽¹⁾	—	0.8	V

NOTES:

- V_{IL} (min.) = -1.0V for pulse width less than tcyc/2, once per cycle.
- V_{IH} (max.) = +6.0V for pulse width less than tcyc/2, once per cycle.

5281 tbl 04

Recommended Operating Temperature and Supply Voltage

Grade	Temperature ⁽¹⁾	Vss	VDD	VDDQ
Commercial	0°C to +70°C	0V	3.3V±5%	3.3V±5%
Industrial	-40°C to +85°C	0V	3.3V±5%	3.3V±5%

NOTES:

5281 tbl 05

1. TA is the "instant on" case temperature.

Pin Configuration - 128K x 36

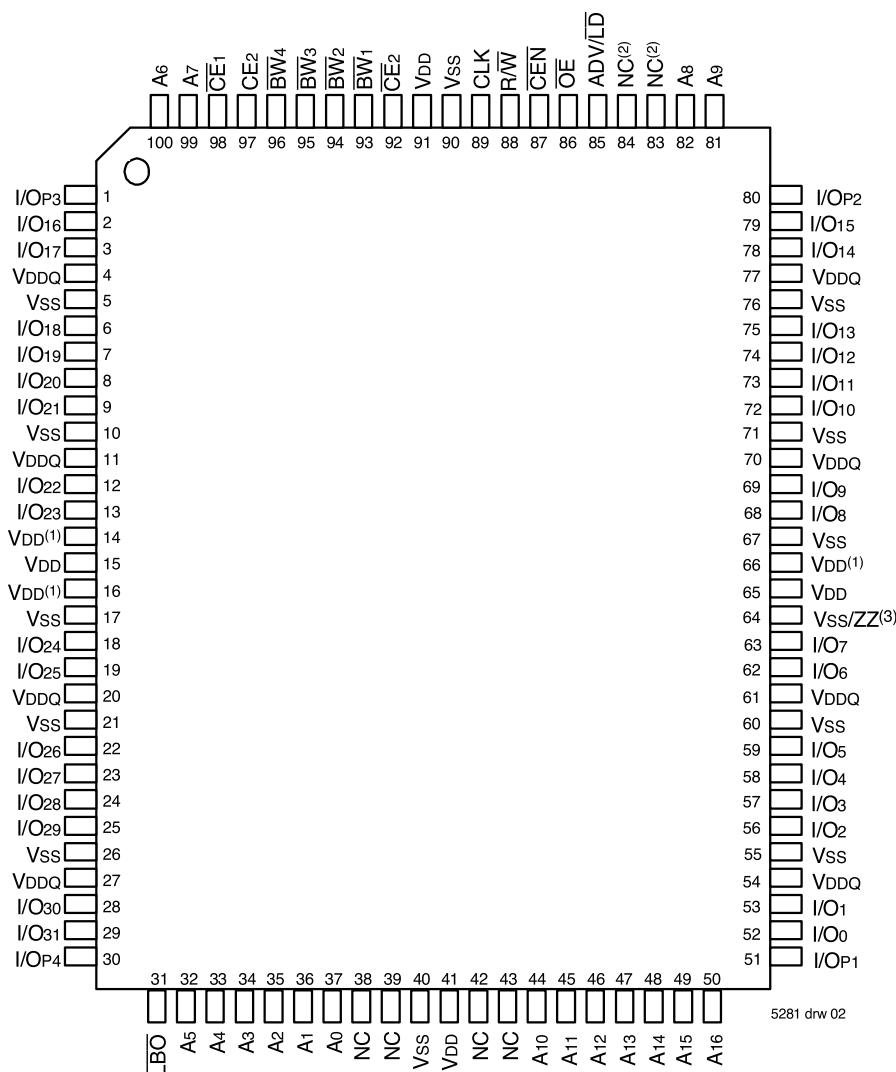

Top View 100 TQFP

NOTES:

1. Pins 14, 16 and 66 do not have to be connected directly to VDD as long as the input voltage is $\geq V_{IH}$.
2. Pins 83 and 84 are reserved for future 8M and 16M respectively.
3. Pin 64 does not have to be connected directly to Vss as long as the input voltage is $\leq V_{IL}$; on the latest die revision this pin supports ZZ (sleep mode).

Pin Configuration - 256K x 18

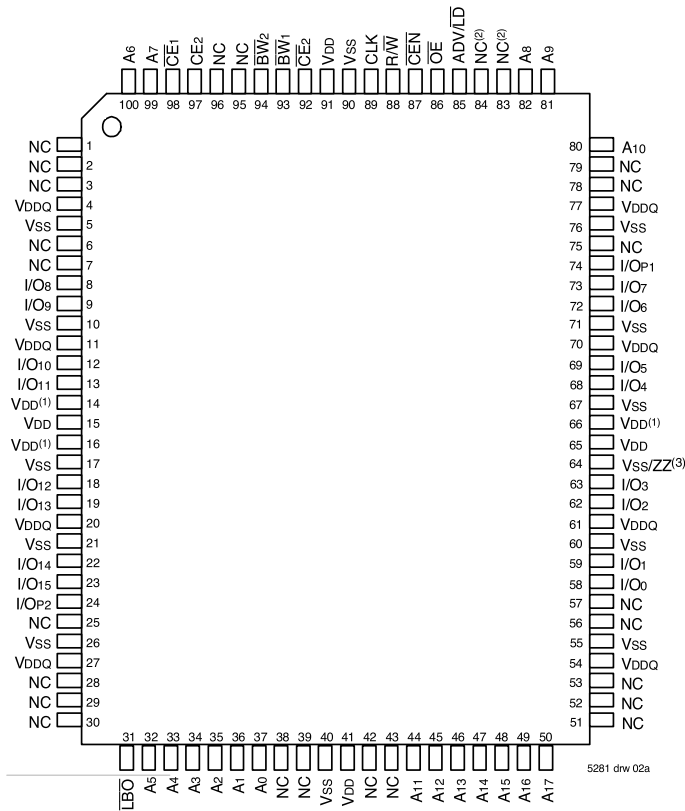

Top View 100 TQFP

NOTES:

1. Pins 14, 16 and 66 do not have to be connected directly to VDD as long as the input voltage is $\geq V_{IH}$.
2. Pins 83 and 84 are reserved for future 8M and 16M respectively.
3. Pin 64 does not have to be connected directly to VSS as long as the input voltage is $\leq V_{IL}$; on the latest die revision this pin supports ZZ (sleep mode).

100 Pin TQFP Capacitance⁽¹⁾ (TA = +25° C, f = 1.0MHz)

Symbol	Parameter ⁽¹⁾	Conditions	Max.	Unit
C _{IN}	Input Capacitance	V _{IN} = 3dV	5	pF
C _{I/O}	I/O Capacitance	V _{OUT} = 3dV	7	pF

5281 tbl 07

NOTE:

1. This parameter is guaranteed by device characterization, but not production tested.

Absolute Maximum Ratings ⁽¹⁾

Symbol	Rating	Commercial & Industrial Values	Unit
V _{TERM} ⁽²⁾	Terminal Voltage with Respect to GND	-0.5 to +4.6	V
V _{TERM} ^(3,6)	Terminal Voltage with Respect to GND	-0.5 to V _{DD}	V
V _{TERM} ^(4,6)	Terminal Voltage with Respect to GND	-0.5 to V _{DD} +0.5	V
V _{TERM} ^(5,6)	Terminal Voltage with Respect to GND	-0.5 to V _{VDDQ} +0.5	V
T _A ⁽⁷⁾	Commercial Operating Temperature	-0 to +70	°C
	Industrial Operating Temperature	-40 to +85	°C
T _{BIAS}	Temperature Under Bias	-55 to +125	°C
T _{STG}	Storage Temperature	-55 to +125	°C
P _T	Power Dissipation	2.0	W
I _{OUT}	DC Output Current	50	mA

NOTES:

1. Stresses greater than those listed under ABSOLUTE MAXIMUM RATINGS may cause permanent damage to the device. This is a stress rating only and functional operation of the device at these or any other conditions above those indicated in the operational sections of this specification is not implied. Exposure to absolute maximum rating conditions for extended periods may affect reliability.
2. V_{DD} terminals only.
3. V_{VDDQ} terminals only.
4. Input terminals only.
5. I/O terminals only.
6. This is a steady-state DC parameter that applies after the power supply has reached its nominal operating value. Power sequencing is not necessary; however, the voltage on any input or I/O pin cannot exceed V_{VDDQ} during power supply ramp up.
7. T_A is the "instant on" case temperature.

5281 tbl 06

Synchronous Truth Table (1)

\overline{CEN}	R/ \overline{W}	Chip ⁽⁵⁾ Enable	ADV/ \overline{LD}	\overline{BWx}	ADDRESS USED	PREVIOUS CYCLE	CURRENT CYCLE	I/O (2 cycles later)
L	L	Select	L	Valid	External	X	LOAD WRITE	D ⁽⁷⁾
L	H	Select	L	X	External	X	LOAD READ	Q ⁽⁷⁾
L	X	X	H	Valid	Internal	LOAD WRITE / BURST WRITE	BURST WRITE (Advance burst counter) ⁽²⁾	D ⁽⁷⁾
L	X	X	H	X	Internal	LOAD READ / BURST READ	BURST READ (Advance burst counter) ⁽²⁾	Q ⁽⁷⁾
L	X	Deselect	L	X	X	X	DESELECT or STOP ⁽³⁾	HiZ
L	X	X	H	X	X	DESELECT / NOOP	NOOP	HiZ
H	X	X	X	X	X	X	SUSPEND ⁽⁴⁾	Previous Value

5281 tbl 08

NOTES:

1. L = V_{IL}, H = V_{IH}, X = Don't Care.
2. When ADV/ \overline{LD} signal is sampled high, the internal burst counter is incremented. The R/ \overline{W} signal is ignored when the counter is advanced. Therefore the nature of the burst cycle (Read or Write) is determined by the status of the R/ \overline{W} signal when the first address is loaded at the beginning of the burst cycle.
3. Deselect cycle is initiated when either ($\overline{CE1}$, or $\overline{CE2}$ is sampled high or CE2 is sampled low) and ADV/ \overline{LD} is sampled low at rising edge of clock. The data bus will tri-state two cycles after deselect is initiated.
4. When \overline{CEN} is sampled high at the rising edge of clock, that clock edge is blocked from propagating through the part. The state of all the internal registers and the I/Os remains unchanged.
5. To select the chip requires $\overline{CE1} = L$, $\overline{CE2} = L$, CE2 = H on these chip enables. Chip is deselected if any one of the chip enables is false.
6. Device Outputs are ensured to be in High-Z after the first rising edge of clock upon power-up.
7. Q - Data read from the device, D - data written to the device.

Partial Truth Table for Writes (1)

OPERATION	R/ \overline{W}	$\overline{BW1}$	$\overline{BW2}$	$\overline{BW3}^{(3)}$	$\overline{BW4}^{(3)}$
READ	H	X	X	X	X
WRITE ALL BYTES	L	L	L	L	L
WRITE BYTE 1 (I/O[0:7], I/OP ₁) ⁽²⁾	L	L	H	H	H
WRITE BYTE 2 (I/O[8:15], I/OP ₂) ⁽²⁾	L	H	L	H	H
WRITE BYTE 3 (I/O[16:23], I/OP ₃) ^(2,3)	L	H	H	L	H
WRITE BYTE 4 (I/O[24:31], I/OP ₄) ^(2,3)	L	H	H	H	L
NO WRITE	L	H	H	H	H

5281 tbl 09

NOTES:

1. L = V_{IL}, H = V_{IH}, X = Don't Care.
2. Multiple bytes may be selected during the same cycle.
3. N/A for X18 configuration.

Interleaved Burst Sequence Table ($\overline{LBO}=V_{DD}$)

	Sequence 1		Sequence 2		Sequence 3		Sequence 4	
	A1	A0	A1	A0	A1	A0	A1	A0
First Address	0	0	0	1	1	0	1	1
Second Address	0	1	0	0	1	1	1	0
Third Address	1	0	1	1	0	0	0	1
Fourth Address ⁽¹⁾	1	1	1	0	0	1	0	0

5281 tbl 10

NOTE:

1. Upon completion of the Burst sequence the counter wraps around to its initial state and continues counting.

Linear Burst Sequence Table ($\overline{LBO}=V_{SS}$)

	Sequence 1		Sequence 2		Sequence 3		Sequence 4	
	A1	A0	A1	A0	A1	A0	A1	A0
First Address	0	0	0	1	1	0	1	1
Second Address	0	1	1	0	1	1	0	0
Third Address	1	0	1	1	0	0	0	1
Fourth Address ⁽¹⁾	1	1	0	0	0	1	1	0

5281 tbl 11

NOTE:

1. Upon completion of the Burst sequence the counter wraps around to its initial state and continues counting.

Functional Timing Diagram (1)

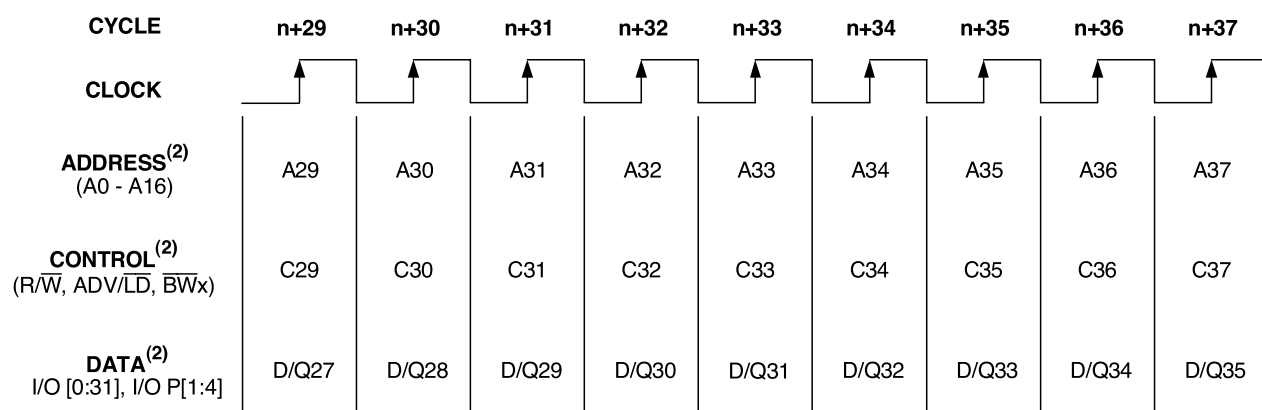

5281 drw 03

NOTES:

1. This assumes \overline{CEN} , $\overline{CE1}$, $CE2$, $\overline{CE2}$ are all true.
2. All Address, Control and Data_In are only required to meet set-up and hold time with respect to the rising edge of clock. Data_Out is valid after a clock-to-data delay from the rising edge of clock.

Device Operation - Showing Mixed Load, Burst, Deselect and NOOP Cycles (2)

Cycle	Address	R \bar{W}	ADV/ $\bar{L}\bar{D}$	$\bar{C}\bar{E}^{(1)}$	$\bar{C}\bar{E}\bar{N}$	$\bar{B}\bar{W}x$	$\bar{O}\bar{E}$	I/O	Comments
n	A ₀	H	L	L	L	X	X	X	Load read
n+1	X	X	H	X	L	X	X	X	Burst read
n+2	A ₁	H	L	L	L	X	L	Q ₀	Load read
n+3	X	X	L	H	L	X	L	Q ₀₊₁	Deselect or STOP
n+4	X	X	H	X	L	X	L	Q ₁	NOOP
n+5	A ₂	H	L	L	L	X	X	Z	Load read
n+6	X	X	H	X	L	X	X	Z	Burst read
n+7	X	X	L	H	L	X	L	Q ₂	Deselect or STOP
n+8	A ₃	L	L	L	L	L	L	Q ₂₊₁	Load write
n+9	X	X	H	X	L	L	X	Z	Burst write
n+10	A ₄	L	L	L	L	L	X	D ₃	Load write
n+11	X	X	L	H	L	X	X	D ₃₊₁	Deselect or STOP
n+12	X	X	H	X	L	X	X	D ₄	NOOP
n+13	A ₅	L	L	L	L	L	X	Z	Load write
n+14	A ₆	H	L	L	L	X	X	Z	Load read
n+15	A ₇	L	L	L	L	L	X	D ₅	Load write
n+16	X	X	H	X	L	L	L	Q ₆	Burst write
n+17	A ₈	H	L	L	L	X	X	D ₇	Load read
n+18	X	X	H	X	L	X	X	D ₇₊₁	Burst read
n+19	A ₉	L	L	L	L	L	L	Q ₈	Load write

5281 tbl 12

NOTES:

- $\bar{C}\bar{E} = L$ is defined as $\bar{C}\bar{E}_1 = L$, $\bar{C}\bar{E}_2 = L$ and $CE_2 = H$. $\bar{C}\bar{E} = H$ is defined as $\bar{C}\bar{E}_1 = H$, $\bar{C}\bar{E}_2 = H$ or $CE_2 = L$.
- H = High; L = Low; X = Don't Care; Z = High Impedance.

Read Operation (1)

Cycle	Address	R \bar{W}	ADV/ $\bar{L}\bar{D}$	$\bar{C}\bar{E}^{(2)}$	$\bar{C}\bar{E}\bar{N}$	$\bar{B}\bar{W}x$	$\bar{O}\bar{E}$	I/O	Comments
n	A ₀	H	L	L	L	X	X	X	Address and Control meet setup
n+1	X	X	X	X	L	X	X	X	Clock Setup Valid
n+2	X	X	X	X	X	X	L	Q ₀	Contents of Address A ₀ Read Out

5281 tbl 13

NOTES:

- H = High; L = Low; X = Don't Care; Z = High Impedance.
- $\bar{C}\bar{E} = L$ is defined as $\bar{C}\bar{E}_1 = L$, $\bar{C}\bar{E}_2 = L$ and $CE_2 = H$. $\bar{C}\bar{E} = H$ is defined as $\bar{C}\bar{E}_1 = H$, $\bar{C}\bar{E}_2 = H$ or $CE_2 = L$.

Burst Read Operation (1)

Cycle	Address	R/ \bar{W}	ADV/ \bar{LD}	$\bar{CE}^{(2)}$	\bar{CEN}	\bar{BW}_x	\bar{OE}	I/O	Comments
n	A ₀	H	L	L	L	X	X	X	Address and Control meet setup
n+1	X	X	H	X	L	X	X	X	Clock Setup Valid, Advance Counter
n+2	X	X	H	X	L	X	L	Q ₀	Address A ₀ Read Out, Inc. Count
n+3	X	X	H	X	L	X	L	Q ₀₊₁	Address A ₀₊₁ Read Out, Inc. Count
n+4	X	X	H	X	L	X	L	Q ₀₊₂	Address A ₀₊₂ Read Out, Inc. Count
n+5	A ₁	H	L	L	L	X	L	Q ₀₊₃	Address A ₀₊₃ Read Out, Load A ₁
n+6	X	X	H	X	L	X	L	Q ₀	Address A ₀ Read Out, Inc. Count
n+7	X	X	H	X	L	X	L	Q ₁	Address A ₁ Read Out, Inc. Count
n+8	A ₂	H	L	L	L	X	L	Q ₁₊₁	Address A ₁₊₁ Read Out, Load A ₂

5281 tbl 14

NOTES:

1. H = High; L = Low; X = Don't Care; Z = High Impedance.
2. $\bar{CE} = L$ is defined as $\bar{CE}_1 = L$, $\bar{CE}_2 = L$ and $CE_2 = H$. $\bar{CE} = H$ is defined as $\bar{CE}_1 = H$, $\bar{CE}_2 = H$ or $CE_2 = L$.

Write Operation (1)

Cycle	Address	R/ \bar{W}	ADV/ \bar{LD}	$\bar{CE}^{(2)}$	\bar{CEN}	\bar{BW}_x	\bar{OE}	I/O	Comments
n	A ₀	L	L	L	L	L	X	X	Address and Control meet setup
n+1	X	X	X	X	L	X	X	X	Clock Setup Valid
n+2	X	X	X	X	L	X	X	D ₀	Write to Address A ₀

5281 tbl 15

NOTES:

1. H = High; L = Low; X = Don't Care; Z = High Impedance.
2. $\bar{CE} = L$ is defined as $\bar{CE}_1 = L$, $\bar{CE}_2 = L$ and $CE_2 = H$. $\bar{CE} = H$ is defined as $\bar{CE}_1 = H$, $\bar{CE}_2 = H$ or $CE_2 = L$.

Burst Write Operation (1)

Cycle	Address	R/ \bar{W}	ADV/ \bar{LD}	$\bar{CE}^{(2)}$	\bar{CEN}	\bar{BW}_x	\bar{OE}	I/O	Comments
n	A ₀	L	L	L	L	L	X	X	Address and Control meet setup
n+1	X	X	H	X	L	L	X	X	Clock Setup Valid, Inc. Count
n+2	X	X	H	X	L	L	X	D ₀	Address A ₀ Write, Inc. Count
n+3	X	X	H	X	L	L	X	D ₀₊₁	Address A ₀₊₁ Write, Inc. Count
n+4	X	X	H	X	L	L	X	D ₀₊₂	Address A ₀₊₂ Write, Inc. Count
n+5	A ₁	L	L	L	L	L	X	D ₀₊₃	Address A ₀₊₃ Write, Load A ₁
n+6	X	X	H	X	L	L	X	D ₀	Address A ₀ Write, Inc. Count
n+7	X	X	H	X	L	L	X	D ₁	Address A ₁ Write, Inc. Count
n+8	A ₂	L	L	L	L	L	X	D ₁₊₁	Address A ₁₊₁ Write, Load A ₂

5281 tbl 16

NOTES:

1. H = High; L = Low; X = Don't Care; ? = Don't Know; Z = High Impedance.
2. $\bar{CE} = L$ is defined as $\bar{CE}_1 = L$, $\bar{CE}_2 = L$ and $CE_2 = H$. $\bar{CE} = H$ is defined as $\bar{CE}_1 = H$, $\bar{CE}_2 = H$ or $CE_2 = L$.

Read Operation with Clock Enable Used (1)

Cycle	Address	R/W	ADV/LD	$\overline{CE}^{(2)}$	\overline{CEN}	\overline{BWx}	\overline{OE}	I/O	Comments
n	A0	H	L	L	L	X	X	X	Address and Control meet setup
n+1	X	X	X	X	H	X	X	X	Clock n+1 Ignored
n+2	A1	H	L	L	L	X	X	X	Clock Valid
n+3	X	X	X	X	H	X	L	Q0	Clock Ignored. Data Q0 is on the bus.
n+4	X	X	X	X	H	X	L	Q0	Clock Ignored. Data Q0 is on the bus.
n+5	A2	H	L	L	L	X	L	Q0	Address A0 Read out (bus trans.)
n+6	A3	H	L	L	L	X	L	Q1	Address A1 Read out (bus trans.)
n+7	A4	H	L	L	L	X	L	Q2	Address A2 Read out (bus trans.)

5281 tbl 17

NOTES:

1. H = High; L = Low; X = Don't Care; Z = High Impedance.
2. $\overline{CE} = L$ is defined as $\overline{CE}_1 = L$, $\overline{CE}_2 = L$ and $CE_2 = H$. $\overline{CE} = H$ is defined as $\overline{CE}_1 = H$, $\overline{CE}_2 = H$ or $CE_2 = L$.

Write Operation with Clock Enable Used (1)

Cycle	Address	R/W	ADV/LD	$\overline{CE}^{(2)}$	\overline{CEN}	\overline{BWx}	\overline{OE}	I/O	Comments
n	A0	L	L	L	L	L	X	X	Address and Control meet setup.
n+1	X	X	X	X	H	X	X	X	Clock n+1 Ignored.
n+2	A1	L	L	L	L	L	X	X	Clock Valid.
n+3	X	X	X	X	H	X	X	X	Clock Ignored.
n+4	X	X	X	X	H	X	X	X	Clock Ignored.
n+5	A2	L	L	L	L	L	X	D0	Write Data D0
n+6	A3	L	L	L	L	L	X	D1	Write Data D1
n+7	A4	L	L	L	L	L	X	D2	Write Data D2

5281 tbl 18

NOTES:

1. H = High; L = Low; X = Don't Care; Z = High Impedance.
2. $\overline{CE} = L$ is defined as $\overline{CE}_1 = L$, $\overline{CE}_2 = L$ and $CE_2 = H$. $\overline{CE} = H$ is defined as $\overline{CE}_1 = H$, $\overline{CE}_2 = H$ or $CE_2 = L$.

Read Operation with CHIP Enable Used (1)

Cycle	Address	R/W	ADV/LD	$\overline{CE}^{(2)}$	\overline{CEN}	\overline{BWx}	\overline{OE}	I/O ⁽³⁾	Comments
n	X	X	L	H	L	X	X	?	Deselected.
n+1	X	X	L	H	L	X	X	?	Deselected.
n+2	A ₀	H	L	L	L	X	X	Z	Address and Control meet setup
n+3	X	X	L	H	L	X	X	Z	Deselected or STOP.
n+4	A ₁	H	L	L	L	X	L	Q ₀	Address A ₀ Read out. Load A ₁ .
n+5	X	X	L	H	L	X	X	Z	Deselected or STOP.
n+6	X	X	L	H	L	X	L	Q ₁	Address A ₁ Read out. Deselected.
n+7	A ₂	H	L	L	L	X	X	Z	Address and control meet setup.
n+8	X	X	L	H	L	X	X	Z	Deselected or STOP.
n+9	X	X	L	H	L	X	L	Q ₂	Address A ₂ Read out. Deselected.

5281 tbl 19

NOTES:

1. H = High; L = Low; X = Don't Care; ? = Don't Know; Z = High Impedance.
2. $\overline{CE} = L$ is defined as $\overline{CE}_1 = L$, $\overline{CE}_2 = L$ and $CE_2 = H$. $\overline{CE} = H$ is defined as $\overline{CE}_1 = H$, $\overline{CE}_2 = H$ or $CE_2 = L$.
3. Device Outputs are ensured to be in High-Z after the first rising edge of clock upon power-up.

Write Operation with Chip Enable Used (1)

Cycle	Address	R/W	ADV/LD	$\overline{CE}^{(2)}$	\overline{CEN}	\overline{BWx}	\overline{OE}	I/O ⁽³⁾	Comments
n	X	X	L	H	L	X	X	?	Deselected.
n+1	X	X	L	H	L	X	X	?	Deselected.
n+2	A ₀	L	L	L	L	L	X	Z	Address and Control meet setup
n+3	X	X	L	H	L	X	X	Z	Deselected or STOP.
n+4	A ₁	L	L	L	L	L	X	D ₀	Address D ₀ Write in. Load A ₁ .
n+5	X	X	L	H	L	X	X	Z	Deselected or STOP.
n+6	X	X	L	H	L	X	X	D ₁	Address D ₁ Write in. Deselected.
n+7	A ₂	L	L	L	L	L	X	Z	Address and control meet setup.
n+8	X	X	L	H	L	X	X	Z	Deselected or STOP.
n+9	X	X	L	H	L	X	X	D ₂	Address D ₂ Write in. Deselected.

5281 tbl 20

NOTES:

1. H = High; L = Low; X = Don't Care; ? = Don't Know; Z = High Impedance.
2. $\overline{CE} = L$ is defined as $\overline{CE}_1 = L$, $\overline{CE}_2 = L$ and $CE_2 = H$. $\overline{CE} = H$ is defined as $\overline{CE}_1 = H$, $\overline{CE}_2 = H$ or $CE_2 = L$.

DC Electrical Characteristics Over the Operating Temperature and Supply Voltage Range (V_{DD} = 3.3V +/-5%)

Symbol	Parameter	Test Conditions	Min.	Max.	Unit
I _L	Input Leakage Current	V _{DD} = Max., V _{IN} = 0V to V _{DD}	—	5	μA
I _L	LBO, JTAG and ZZ Input Leakage Current ⁽¹⁾	V _{DD} = Max., V _{IN} = 0V to V _{DD}	—	30	μA
I _{LO}	Output Leakage Current	V _{OUT} = 0V to V _{DDQ} , Device Deselected	—	5	μA
V _{OL}	Output Low Voltage	I _{OL} = +8mA, V _{DD} = Min.	—	0.4	V
V _{OH}	Output High Voltage	I _{OH} = -8mA, V _{DD} = Min.	2.4	—	V

5281 tbl 21

NOTE:

1. The LBO, TMS, TDI, TCK and TRST pins will be internally pulled to V_{DD} and ZZ will be internally pulled if they are not actively driven in the application.

DC Electrical Characteristics Over the Operating Temperature and Supply Voltage Range ⁽¹⁾ (V_{DD} = 3.3V +/-5%)

Symbol	Parameter	Test Conditions	200MHz ⁽⁴⁾	166MHz		133MHz		100MHz		Unit
			Com'l Only	Com'l	Ind	Com'l	Ind	Com'l	Ind	
I _{DD}	Operating Power Supply Current	Device Selected, Outputs Open, ADV/LD = X, V _{DD} = Max., V _{IN} ≥ V _{IH} or ≤ V _{IL} , f = f _{MAX} ⁽²⁾	400	350	360	300	310	250	255	mA
I _{SB1}	CMOS Standby Power Supply Current	Device Deselected, Outputs Open, V _{DD} = Max., V _{IN} ≥ V _H D or ≤ V _L D, f = 0 ^(2,3)	40	40	45	40	45	40	45	mA
I _{SB2}	Clock Running Power Supply Current	Device Deselected, Outputs Open, V _{DD} = Max., V _{IN} ≥ V _H D or < V _L D, f = f _{MAX} ^(2,3)	130	120	130	110	120	100	110	mA
I _{SB3}	Idle Power Supply Current	Device Selected, Outputs Open, CEN ≥ V _{IH} , V _{DD} = Max., V _{IN} ≥ V _H D or ≤ V _L D, f = f _{MAX} ^(2,3)	40	40	45	40	45	40	45	mA

5281 tbl 22

NOTES:

- All values are maximum guaranteed values.
- At f = f_{MAX}, inputs are cycling at the maximum frequency of read cycles of 1/t_{CYC}; f=0 means no input lines are changing.
- For I/Os V_HD = V_{DDQ} - 0.2V, V_LD = 0.2V. For other inputs V_HD = V_{DD} - 0.2V, V_LD = 0.2V.
- Only available in 256K x 18 configuration.

AC Test Loads

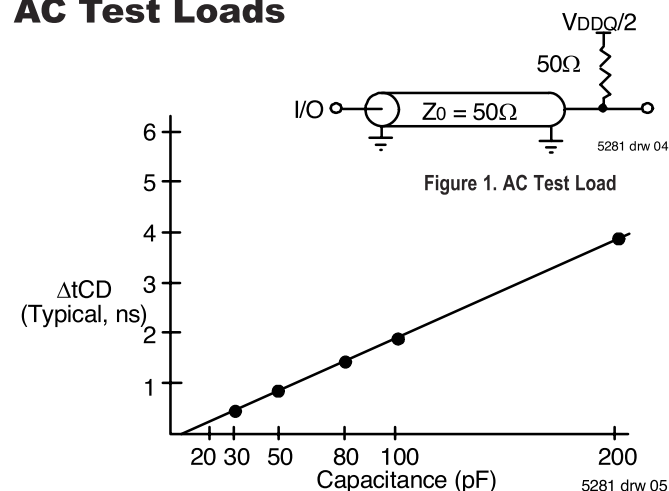

Figure 2. Lumped Capacitive Load, Typical Derating

AC Test Conditions (V_{DDQ} = 3.3V)

Input Pulse Levels	0 to 3V
Input Rise/Fall Times	2ns
Input Timing Reference Levels	1.5V
Output Timing Reference Levels	1.5V
AC Test Load	See Figure 1

5281 tbl 23

AC Electrical Characteristics (VDD = 3.3V +/-5%, Commercial and Industrial Temperature Ranges)

Symbol	Parameter	200MHz ⁽⁶⁾		166MHz		133MHz		100MHz		Unit
		Min.	Max.	Min.	Max.	Min.	Max.	Min.	Max.	
t _{CYC}	Clock Cycle Time	5	—	6	—	7.5	—	10	—	ns
t _F ⁽¹⁾	Clock Frequency	—	200	—	166	—	133	—	100	MHz
t _{CH} ⁽²⁾	Clock High Pulse Width	1.8	—	1.8	—	2.2	—	3.2	—	ns
t _{CL} ⁽²⁾	Clock Low Pulse Width	1.8	—	1.8	—	2.2	—	3.2	—	ns
Output Parameters										
t _{CD}	Clock High to Valid Data	—	3.2	—	3.5	—	4.2	—	5	ns
t _{DC}	Clock High to Data Change	1	—	1	—	1	—	1	—	ns
t _{CLZ} ^(3,4,5)	Clock High to Output Active	1	—	1	—	1	—	1	—	ns
t _{CHZ} ^(3,4,5)	Clock High to Data High-Z	1	3	1	3	1	3	1	3.3	ns
t _{OE}	Output Enable Access Time	—	3.2	—	3.5	—	4.2	—	5	ns
t _{OLZ} ^(3,4)	Output Enable Low to Data Active	0	—	0	—	0	—	0	—	ns
t _{OHZ} ^(3,4)	Output Enable High to Data High-Z	—	3.5	—	3.5	—	4.2	—	5	ns
Set Up Times										
t _{SE}	Clock Enable Setup Time	1.5	—	1.5	—	1.7	—	2.0	—	ns
t _{SA}	Address Setup Time	1.5	—	1.5	—	1.7	—	2.0	—	ns
t _{SD}	Data In Setup Time	1.5	—	1.5	—	1.7	—	2.0	—	ns
t _{SW}	Read/Write (R/W) Setup Time	1.5	—	1.5	—	1.7	—	2.0	—	ns
t _{ADV}	Advance/Load (ADV/LD) Setup Time	1.5	—	1.5	—	1.7	—	2.0	—	ns
t _{SC}	Chip Enable/Select Setup Time	1.5	—	1.5	—	1.7	—	2.0	—	ns
t _{SB}	Byte Write Enable (BWx) Setup Time	1.5	—	1.5	—	1.7	—	2.0	—	ns
Hold Times										
t _{HE}	Clock Enable Hold Time	0.5	—	0.5	—	0.5	—	0.5	—	ns
t _{HA}	Address Hold Time	0.5	—	0.5	—	0.5	—	0.5	—	ns
t _{HD}	Data In Hold Time	0.5	—	0.5	—	0.5	—	0.5	—	ns
t _{HW}	Read/Write (R/W) Hold Time	0.5	—	0.5	—	0.5	—	0.5	—	ns
t _{HADV}	Advance/Load (ADV/LD) Hold Time	0.5	—	0.5	—	0.5	—	0.5	—	ns
t _{HC}	Chip Enable/Select Hold Time	0.5	—	0.5	—	0.5	—	0.5	—	ns
t _{HB}	Byte Write Enable (BWx) Hold Time	0.5	—	0.5	—	0.5	—	0.5	—	ns

NOTES:

- t_F = 1/t_{CYC}.
- Measured as HIGH above 0.6V_{DDQ} and LOW below 0.4V_{DDQ}.
- Transition is measured ±200mV from steady-state.
- These parameters are guaranteed with the AC load (Figure 1) by device characterization. They are not production tested.
- To avoid bus contention, the output buffers are designed such that t_{CHZ} (device turn-off) is about 1ns faster than t_{CLZ} (device turn-on) at a given temperature and voltage. The specs as shown do not imply bus contention because t_{CLZ} is a Min. parameter that is worse case at totally different test conditions (0 deg. C, 3.465V) than t_{CHZ}, which is a Max. parameter (worse case at 70 deg. C, 3.135V).
- Commercial temperature range only. Only available in 256K x 18 configuration.

5281 tbl 24

Timing Waveform of Read Cycle (1,2,3,4)

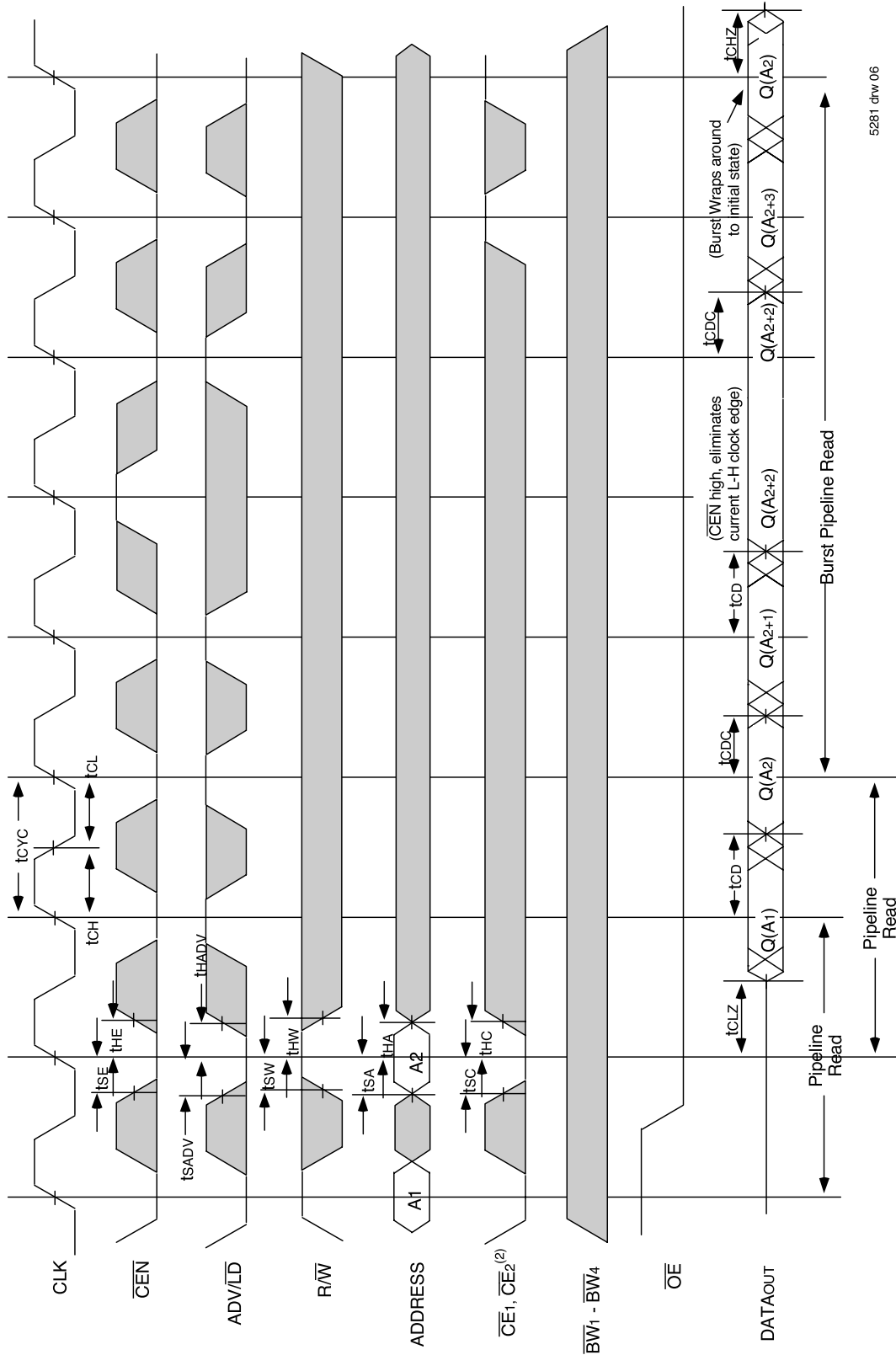

5281 drw.06

NOTES:

1. Q(A1) represents the first output from the external address A1. Q(A2) represents the first output from the external address A2; Q(A2+1) represents the next output data in the burst sequence of the base address A2, etc. where address bits A0 and A1 are advancing for the four word burst in the sequence defined by the state of the LBO input.
2. CE2 timing transitions are identical but inverted to the CE1 and CE2 signals. For example, when CE1 and CE2 are LOW on this waveform, CE2 is HIGH.
3. Burst ends when new address and control are loaded into the SRAM by sampling ADV/LD LOW.
4. R/W is don't care when the SRAM is bursting (ADV/LD sampled HIGH). The nature of the burst access (Read or Write) is fixed by the state of the R/W signal when new address and control are loaded into the SRAM.

Timing Waveform of Write Cycles (1,2,3,4,5)

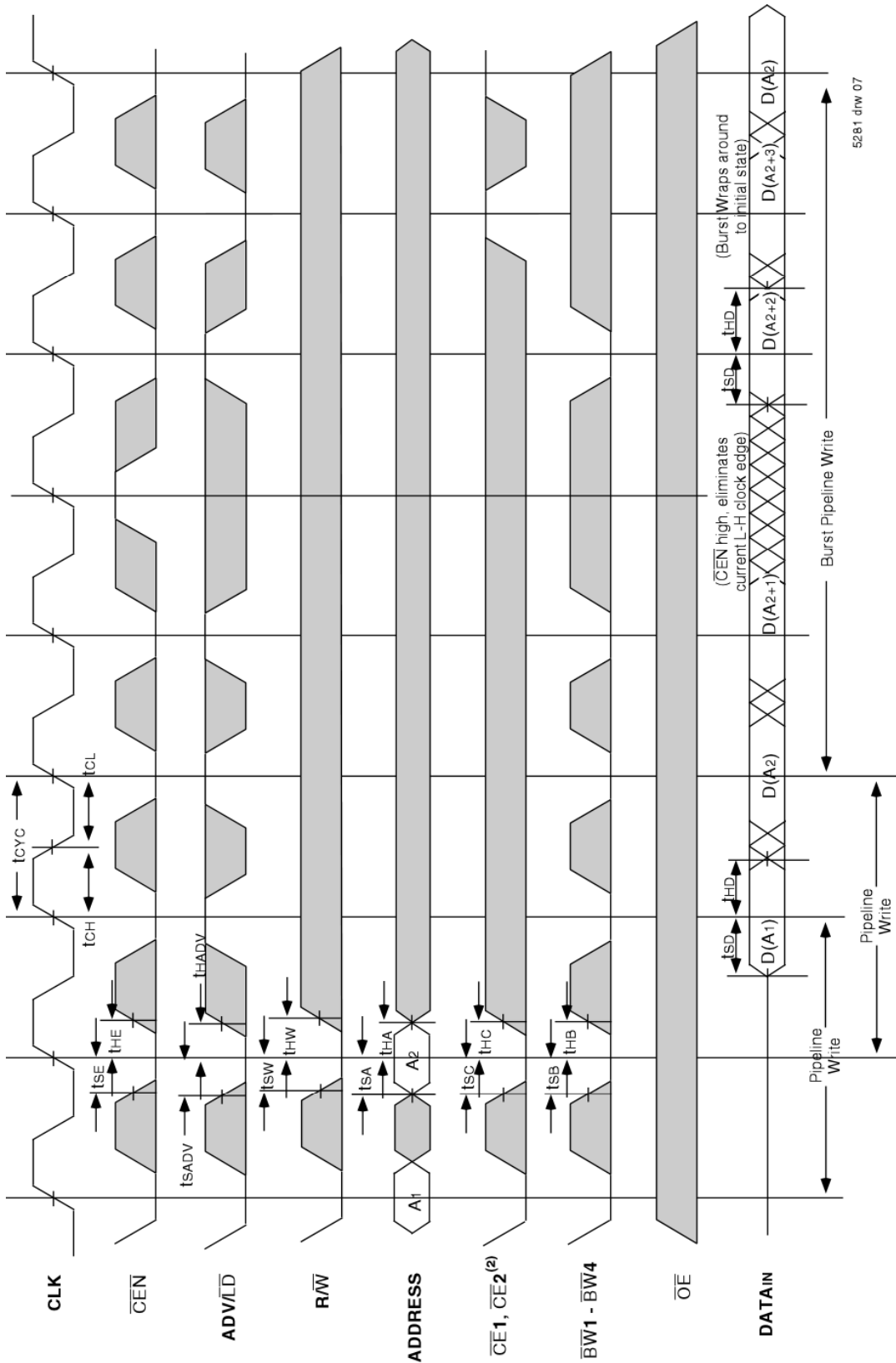

5281 drw 07

NOTES:

1. D (A1) represents the first input to the external address A1. D (A2) represents the first input to the external address A2; D (A2+1) represents the next input data in the burst sequence of the base address A2, etc. where address bits A0 and A1 are advancing for the four word burst in the sequence defined by the state of the LBO input.
2. CEz timing transitions are identical but inverted to the CE1 and CE2 signals. For example, when CE1 and CE2 are LOW on this waveform, CE2 is HIGH.
3. Burst ends when new address and control are loaded into the SRAM by sampling ADVLD LOW.
4. RW is don't care when the SRAM is bursting (ADVLD sampled HIGH). The nature of the burst access (Read or Write) is fixed by the state of the RW signal when new address and control are loaded into the SRAM.
5. Individual Byte Write signals (BWx) must be valid on all write and burst-write cycles. A write cycle is initiated when RW signal is sampled LOW. The byte write information comes in two cycles before the actual data is presented to the SRAM.

Timing Waveform of Combined Read and Write Cycles (1,2,3)

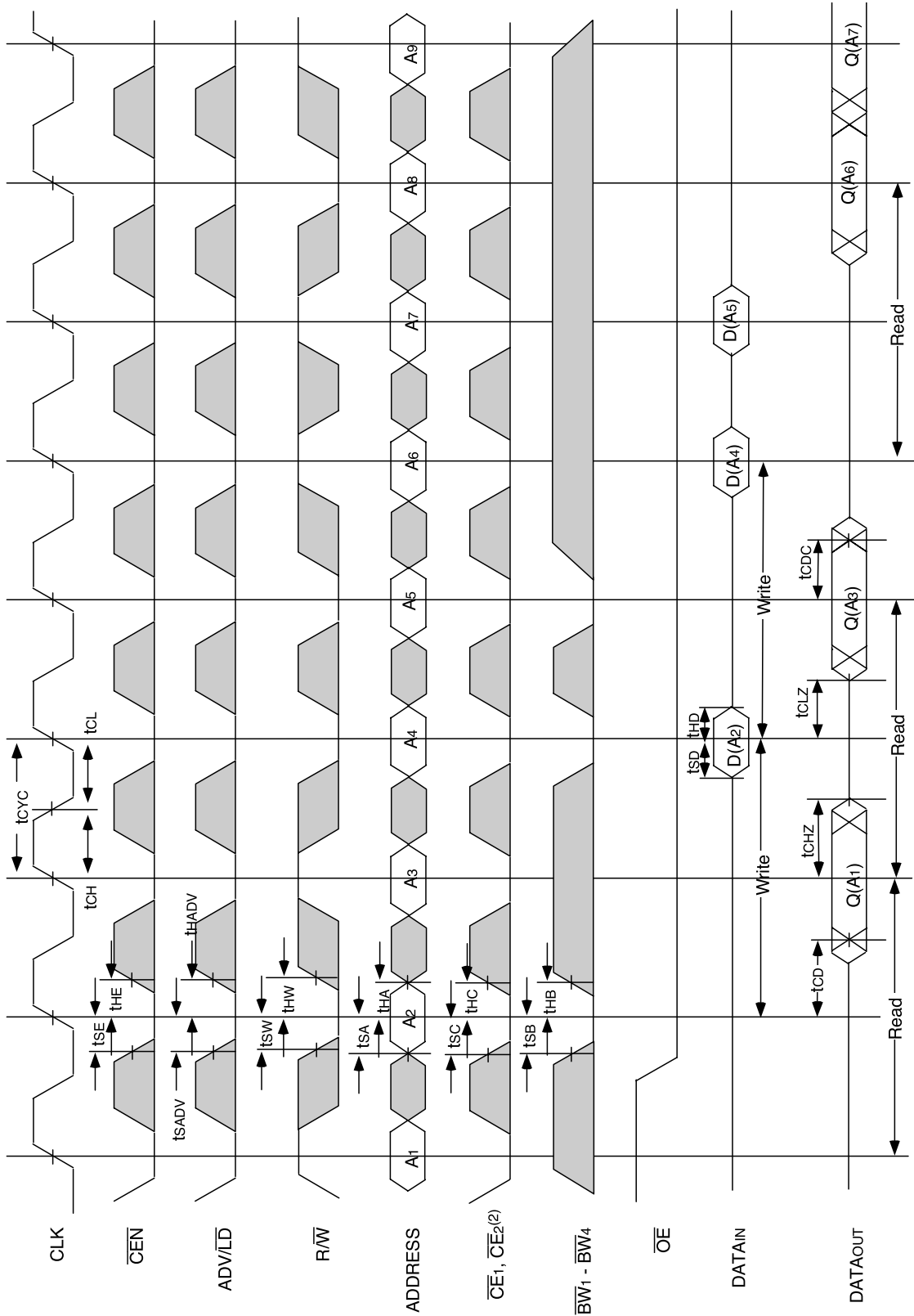

5281 drw 08

NOTES:

1. Q(A₁) represents the first output from the external address A₁. D(A₂) represents the input data to the SRAM corresponding to address A₂.
2. CE₂ timing transitions are identical but inverted to the CE₁ and CE₂ signals. For example, when CE₁ and CE₂ are LOW on this waveform, CE₂ is HIGH.
3. Individual Byte Write signals (BW_x) must be valid on all write and burst-write cycles. A write cycle is initiated when RW signal is sampled LOW. The byte write information comes in two cycles before the actual data is presented to the SRAM.

Timing Waveform of CEN Operation (1,2,3,4)

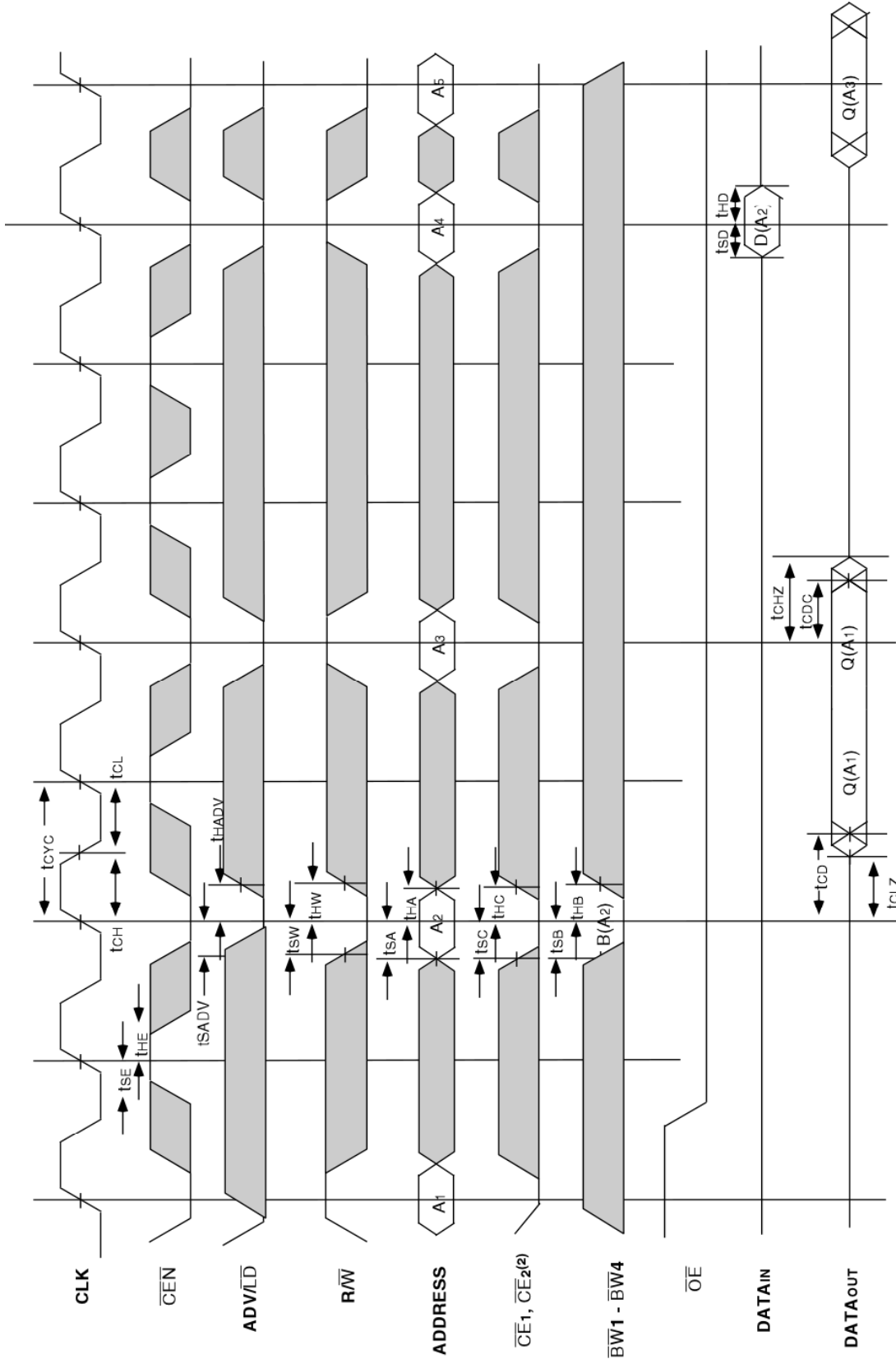

5281 drw 03

NOTES:

1. Q (A1) represents the first output from the external address A1. D (A2) represents the input data to the SRAM corresponding to address A2.
2. CEz timing transitions are identical but inverted to the $\overline{CE1}$ and $\overline{CE2}$ signals. For example, when $\overline{CE1}$ and $\overline{CE2}$ are LOW on this waveform, CEz is HIGH.
3. \overline{CEN} when sampled high on the rising edge of clock will block that L-H transition of the clock from propagating into the SRAM. The part will behave as if the L-H clock transition did not occur. All internal registers in the SRAM will retain their previous state.
4. Individual Byte Write signals (\overline{BWx}) must be valid on all write and burst-write cycles. A write cycle is initiated when \overline{RW} signal is sampled LOW. The byte write information comes in two cycles before the actual data is presented to the SRAM.

Timing Waveform of $\overline{\text{CS}}$ Operation (1,2,3,4)

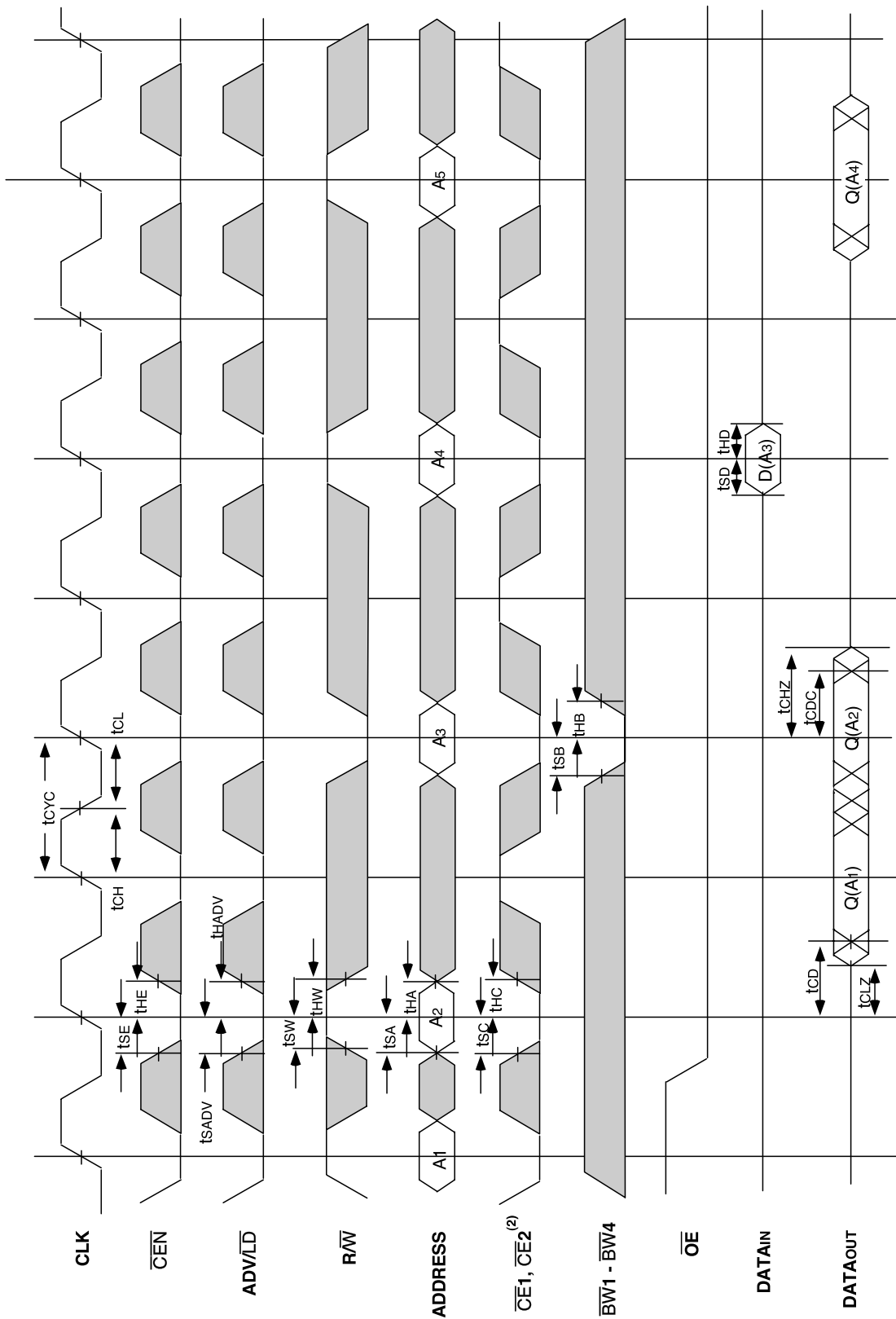

5281 drw 10

NOTES:

1. Q(A1) represents the first output from the external address A1. D(A3) represents the input data to the SRAM corresponding to address A3.
2. CE2 timing transitions are identical but inverted to the CE1 and CE2 signals. For example, when CE1 and CE2 are LOW on this waveform, CE2 is HIGH.
3. $\overline{\text{CEN}}$ when sampled high on the rising edge of clock will block that L-H transition of the clock from propagating into the SRAM. The part will behave as if the L-H clock transition did not occur. All internal registers in the SRAM will retain their previous state.
4. Individual Byte Write signals ($\overline{\text{BWx}}$) must be valid on all write and burst-write cycles. A write cycle is initiated when $\overline{\text{R/W}}$ signal is sampled LOW. The byte write information comes in two cycles before the actual data is presented to the SRAM.

100-Pin Plastic Thin Quad Flatpack (TQFP) Package Diagram Outline

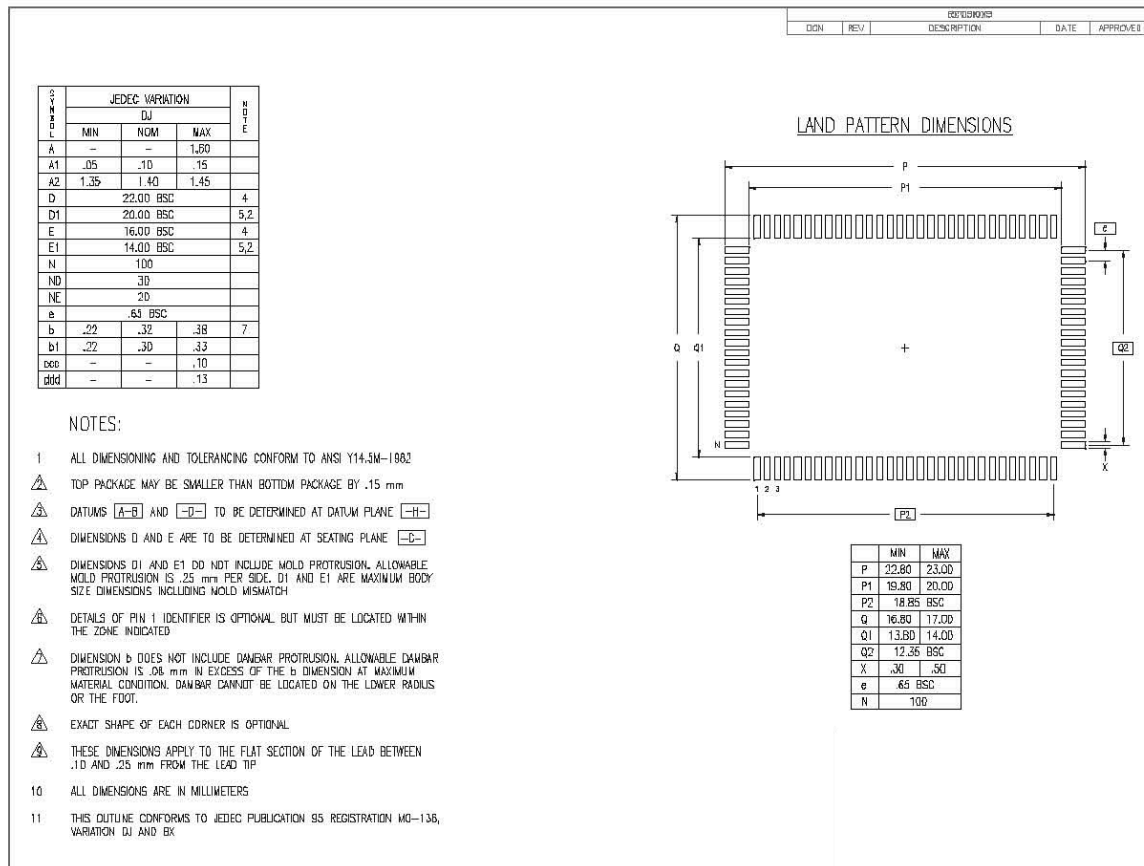
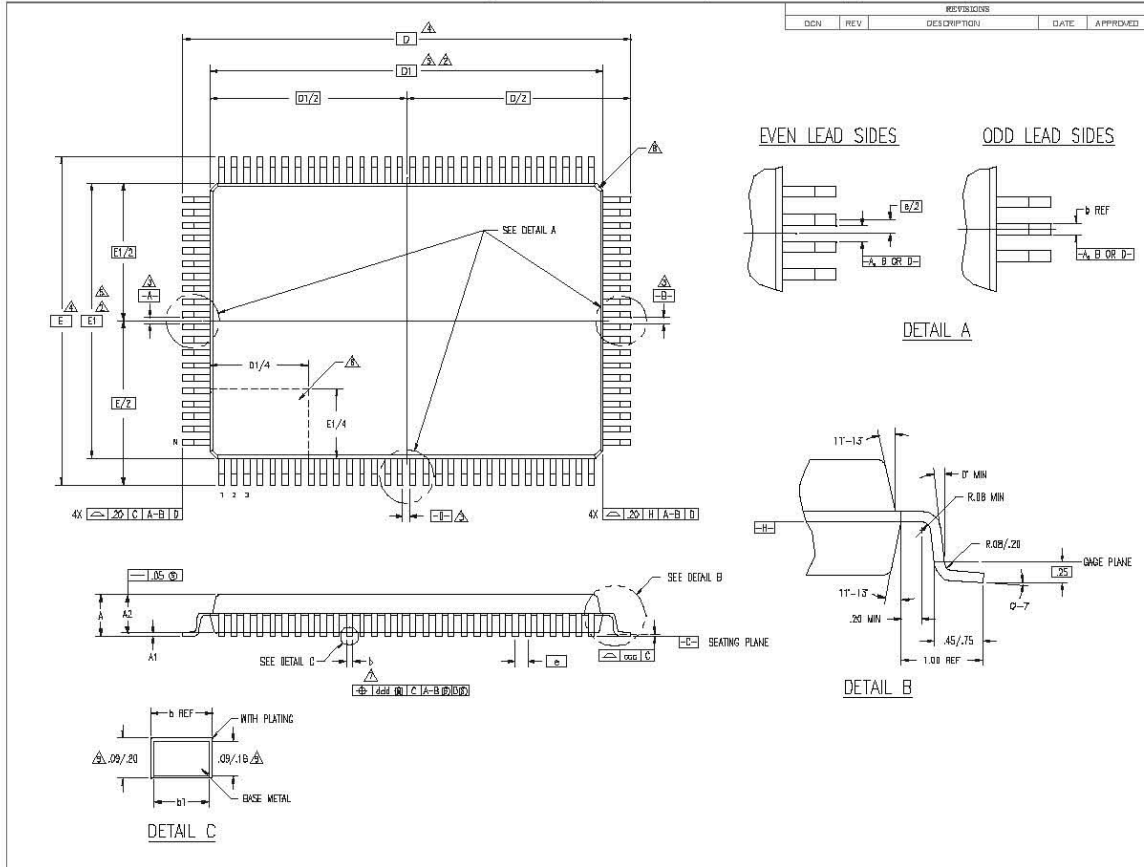

Timing Waveform of \overline{OE} Operation (1)

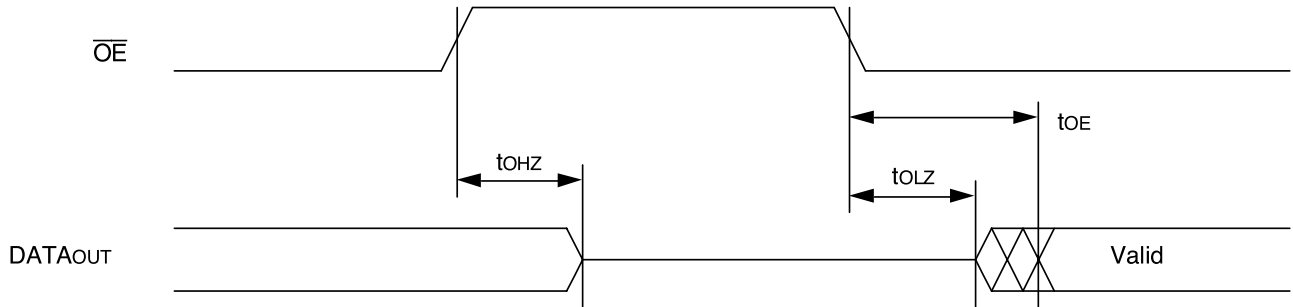

5281 dw 11

NOTE:

1. A read operation is assumed to be in progress.

Alliance Part numbering system

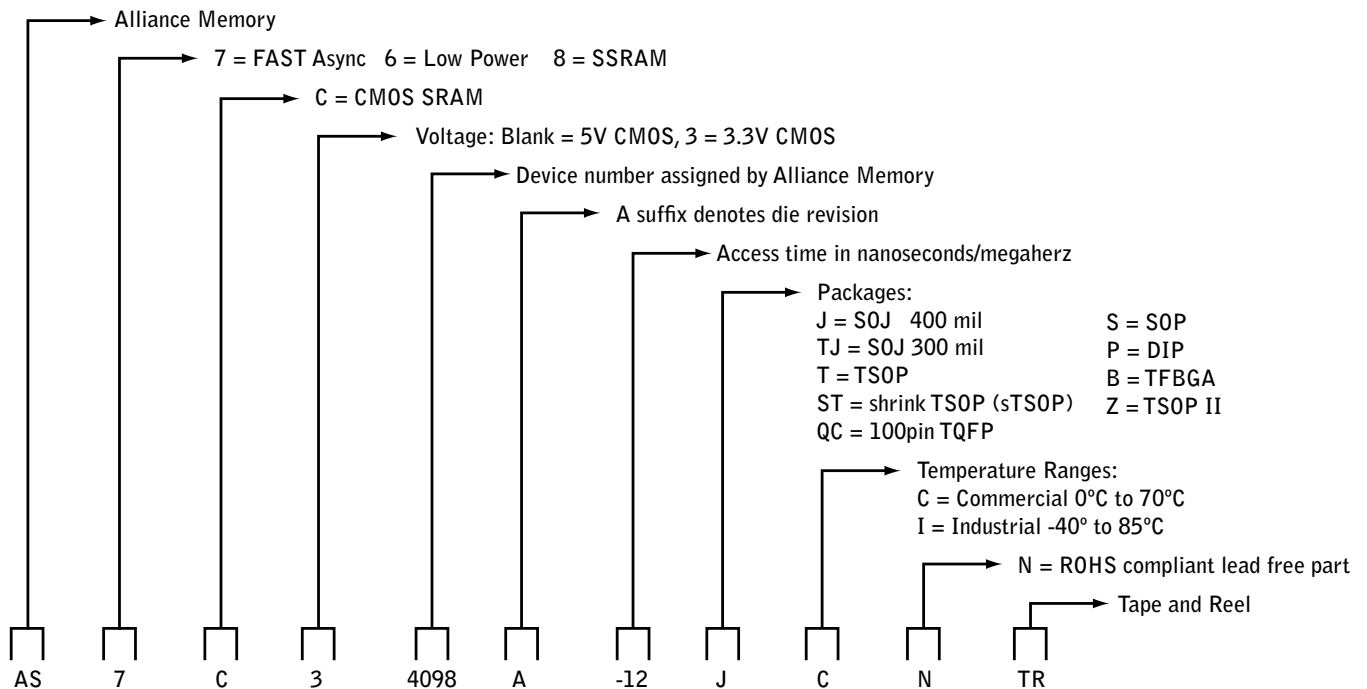

Ordering Information

Alliance	Organization	VCC Range	Package	Operating Temp	Speed
AS8C403601-QC166N	128K x 36	3.1 - 3.4V	100 pin TQFP	Comercial 0 - 70C	166MHz
AS8C401801-QC166N	256K x 18	3.1 - 3.4V	100 pin TQFP	Comercial 0 - 70C	166MHz

AMEYA360

Components Supply Platform

Authorized Distribution Brand :



Website :

Welcome to visit www.ameya360.com

Contact Us :

➤ Address :

401 Building No.5, JiuGe Business Center, Lane 2301, Yishan Rd
Minhang District, Shanghai , China

➤ Sales :

Direct +86 (21) 6401-6692

Email amall@ameya360.com

QQ 800077892

Skype [ameyasales1](#) [ameyasales2](#)

➤ Customer Service :

Email service@ameya360.com

➤ Partnership :

Tel +86 (21) 64016692-8333

Email mkt@ameya360.com