

S70FL01GS

1 Gbit (128 Mbyte) MirrorBit® Flash Non-Volatile Memory
CMOS 3.0 Volt Core
Serial Peripheral Interface with Multi-I/O

Data Sheet (Preliminary)



Notice to Readers: This document states the current technical specifications regarding the Spansion product(s) described herein. Each product described herein may be designated as Advance Information, Preliminary, or Full Production. See [Notice On Data Sheet Designations](#) for definitions.

Notice On Data Sheet Designations

Spansion Inc. issues data sheets with Advance Information or Preliminary designations to advise readers of product information or intended specifications throughout the product life cycle, including development, qualification, initial production, and full production. In all cases, however, readers are encouraged to verify that they have the latest information before finalizing their design. The following descriptions of Spansion data sheet designations are presented here to highlight their presence and definitions.

Advance Information

The Advance Information designation indicates that Spansion Inc. is developing one or more specific products, but has not committed any design to production. Information presented in a document with this designation is likely to change, and in some cases, development on the product may discontinue. Spansion Inc. therefore places the following conditions upon Advance Information content:

“This document contains information on one or more products under development at Spansion Inc. The information is intended to help you evaluate this product. Do not design in this product without contacting the factory. Spansion Inc. reserves the right to change or discontinue work on this proposed product without notice.”

Preliminary

The Preliminary designation indicates that the product development has progressed such that a commitment to production has taken place. This designation covers several aspects of the product life cycle, including product qualification, initial production, and the subsequent phases in the manufacturing process that occur before full production is achieved. Changes to the technical specifications presented in a Preliminary document should be expected while keeping these aspects of production under consideration. Spansion places the following conditions upon Preliminary content:

“This document states the current technical specifications regarding the Spansion product(s) described herein. The Preliminary status of this document indicates that product qualification has been completed, and that initial production has begun. Due to the phases of the manufacturing process that require maintaining efficiency and quality, this document may be revised by subsequent versions or modifications due to changes in technical specifications.”

Combination

Some data sheets contain a combination of products with different designations (Advance Information, Preliminary, or Full Production). This type of document distinguishes these products and their designations wherever necessary, typically on the first page, the ordering information page, and pages with the DC Characteristics table and the AC Erase and Program table (in the table notes). The disclaimer on the first page refers the reader to the notice on this page.

Full Production (No Designation on Document)

When a product has been in production for a period of time such that no changes or only nominal changes are expected, the Preliminary designation is removed from the data sheet. Nominal changes may include those affecting the number of ordering part numbers available, such as the addition or deletion of a speed option, temperature range, package type, or V_{IO} range. Changes may also include those needed to clarify a description or to correct a typographical error or incorrect specification. Spansion Inc. applies the following conditions to documents in this category:

“This document states the current technical specifications regarding the Spansion product(s) described herein. Spansion Inc. deems the products to have been in sufficient production volume such that subsequent versions of this document are not expected to change. However, typographical or specification corrections, or modifications to the valid combinations offered may occur.”

Questions regarding these document designations may be directed to your local sales office.

S70FL01GS

1 Gbit (128 Mbyte) MirrorBit® Flash Non-Volatile Memory
CMOS 3.0 Volt Core
Serial Peripheral Interface with Multi-I/O



Data Sheet (Preliminary)

Features

- **Serial Peripheral Interface (SPI)**
 - SPI Clock polarity and phase modes 0 and 3
 - Double Data Rate (DDR) option
 - Extended Addressing: 32-bit address
 - Serial Command set and footprint compatible with S25FL-A, S25FL-K, and S25FL-P SPI families
 - Multi I/O Command set and footprint compatible with S25FL-P SPI family
- **READ Commands**
 - Normal, Fast, Dual, Quad, Fast DDR, Dual DDR, Quad DDR
 - AutoBoot – power up or reset and execute a Normal or Quad read command automatically at a preselected address
 - Common Flash Interface (CFI) data for configuration information
- **Programming (1.5 Mbytes/s)**
 - 512-byte Page Programming buffer
 - Quad-Input Page Programming (QPP) for slow clock systems
- **Erase (0.5 Mbytes/s)**
 - Uniform 256-kbyte sectors
- **Cycling Endurance**
 - 100,000 Program-Erase Cycles on any sector typical
- **Data Retention**
 - 20 Year Data Retention typical

Security Features

- **One Time Program (OTP) array of 1024 bytes**
- **Block Protection**
 - Status Register bits to control protection against program or erase of a contiguous range of sectors.
 - Hardware and software control options
 - Advanced Sector Protection (ASP)
 - Individual sector protection controlled by boot code or password
- **Spansion 65 nm MirrorBit Technology with Eclipse™ Architecture**
- **Core Supply Voltage: 2.7V to 3.6V**
- **I/O Supply Voltage: 1.65V to 3.6V**
- **Temperature Range:**
 - Industrial (-40°C to +85°C)
 - Automotive In-Cabin (-40°C to +105°C)
- **Packages (all Pb-free)**
 - 16-lead SOIC (300 mils)

General Description

This document contains information for the S70FL01GS device, which is a dual die stack of two S25FL512S die. For detailed specifications, please refer to the discrete die data sheet:

Document	Publication Identification Number (PID)
S25FL512S Data Sheet	S25FL512S_00

Table of Contents

Features	3
General Description	3
1. Block Diagram	7
2. Connection Diagrams	8
3. Input/Output Summary	8
4. Ordering Information	9
4.1 Valid Combinations	9
5. Device Operations	10
5.1 Programming	10
5.2 Simultaneous Die Operation	10
5.3 Sequential Reads	10
5.4 Sector/Bulk Erase	10
5.5 Status Registers	10
5.6 Configuration Register	10
5.7 Bank Address Register	10
5.8 ASP Register, Password Register, PPB Lock Register, PPB Access Register, DYB Access Register, DDR Data Learning Registers	10
5.9 Block Protection	10
6. Read Identification (RDID)	11
7. RESET#	11
8. Versatile I/O Power Supply (V_{IO})	11
9. DC Characteristics	12
10. AC Test Conditions	13
11. SDR AC Characteristics	14
11.1 DDR AC Characteristics	15
11.2 Capacitance Characteristics	15
12. SOIC 16 Physical Diagram	16
12.1 SO3016 — 16-pin Wide Plastic Small Outline Package (300-mil Body Width)	16
13. Revision History	17

Figures

Figure 2.1	16-pin Plastic Small Outline Package (SO)	8
Figure 10.1	Input, Output, and Timing Reference Levels	13
Figure 10.2	Test Setup	13

Tables

Table 3.1	Signal List	8
Table 4.1	S70FL01GS Valid Combinations Table	9
Table 6.1	Product Group CFI Device Geometry Definition	11
Table 9.1	DC Characteristics	12
Table 10.1	AC Measurement Conditions	13
Table 11.1	SDR AC Characteristics (Single Die Package, $V_{CC} = 2.7V$ to $3.6V$)	14
Table 11.2	DDR AC Characteristics 66 MHz Operation	15
Table 11.3	Capacitance	15

1. Block Diagram

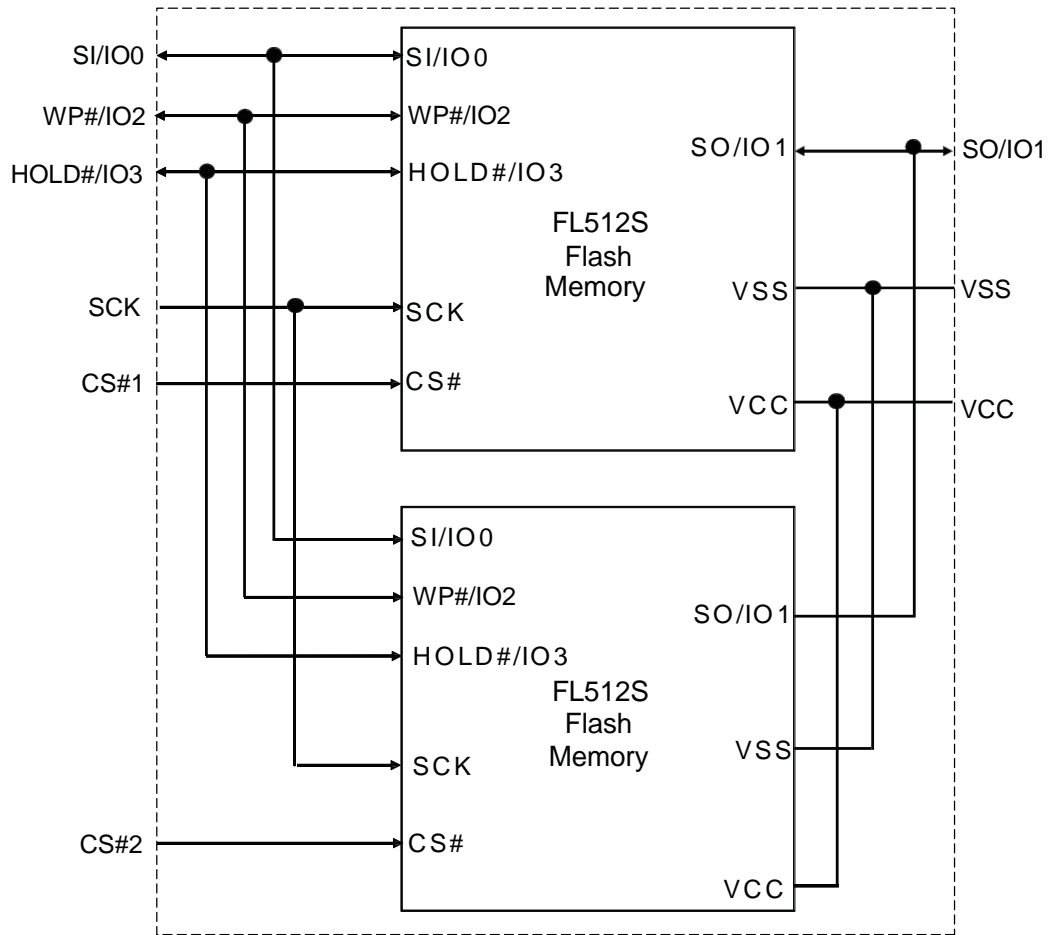

2. Connection Diagrams

Figure 2.1 16-pin Plastic Small Outline Package (SO)

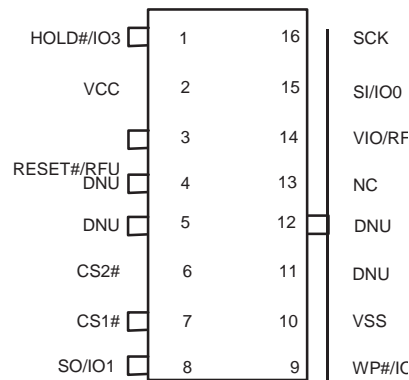

Note:

1. V_{IO} (pin 14) is not supported in the S70FL01GS device and is RFU. Refer to Section 8. for more details.

3. Input/Output Summary

Table 3.1 Signal List

Signal Name	Type	Description
RESET#	Input	Hardware Reset: Low = device resets and returns to standby state, ready to receive a command. The signal has an internal pull-up resistor and may be left unconnected in the host system if not used.
SCK	Input	Serial Clock.
CS#	Input	Chip Select.
SI / IO0	I/O	Serial Input for single bit data commands or IO0 for Dual or Quad commands.
SO / IO1	I/O	Serial Output for single bit data commands. IO1 for Dual or Quad commands.
WP# / IO2	I/O	Write Protect when not in Quad mode. IO2 in Quad mode. The signal has an internal pull-up resistor and may be left unconnected in the host system if not used for Quad commands.
HOLD# / IO3	I/O	Hold (pause) serial transfer in single bit or Dual data commands. IO3 in Quad-I/O mode. The signal has an internal pull-up resistor and may be left unconnected in the host system if not used for Quad commands.
V_{CC}	Supply	Core Power Supply.
V_{IO}	Supply	Versatile I/O Power Supply. Note: V_{IO} is not supported in the S70FL01GS device. Refer to Section 8. for more details.
V_{SS}	Supply	Ground.
NC	Unused	Not Connected. No device internal signal is connected to the package connector nor is there any future plan to use the connector for a signal. The connection may safely be used for routing space for a signal on a Printed Circuit Board (PCB). However, any signal connected to an NC must not have voltage levels higher than V_{CC} .
RFU	Reserved	Reserved for Future Use. No device internal signal is currently connected to the package connector but there is potential future use of the connector for a signal. It is recommended to not use RFU connectors for PCB routing channels so that the PCB may take advantage of future enhanced features in compatible footprint devices.
DNU	Reserved	Do Not Use. A device internal signal may be connected to the package connector. The connection may be used by Spansion for test or other purposes and is not intended for connection to any host system signal. Any DNU signal related function will be inactive when the signal is at V_{IL} . The signal has an internal pull-down resistor and may be left unconnected in the host system or may be tied to V_{SS} . Do not use these connections for PCB signal routing channels. Do not connect any host system signal to this connection.

4. Ordering Information

The ordering part number is formed by a valid combination of the following:

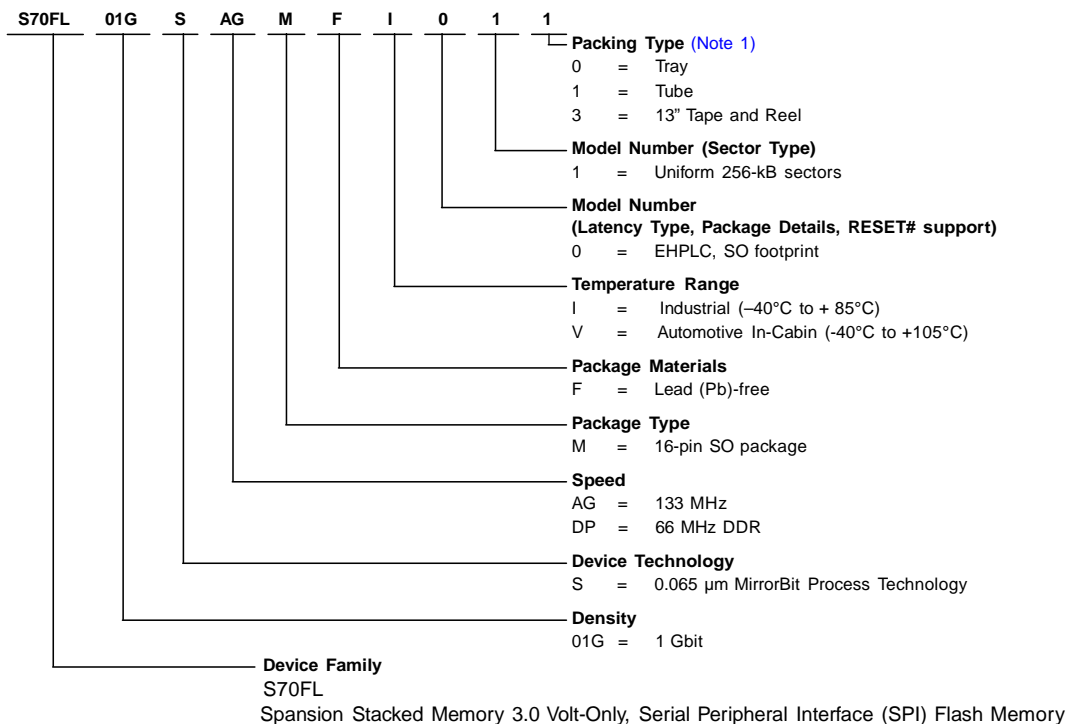

Notes:

1. EHPLC = Enhanced High Performance Latency Code table.
2. Uniform 256-kB sectors = All sectors are uniform 256-kB with a 512B programming buffer.

4.1 Valid Combinations

Table 4.1 lists the valid combinations configurations planned to be supported in volume for this device.

Table 4.1 S70FL01GS Valid Combinations Table

S70FL01GS Valid Combinations					Package Marking (1)
Base Ordering Part Number	Speed Option	Package and Temperature	Model Number	Packing Type	
S70FL01GS	AG	MFI	01	0, 1, 3	FL01GS+A+(temp)+F+(Model Number)
S70FL01GS	DP				FL01GS+D+(temp)+F+(Model Number)

Note:

1. Package Marking omits the leading "S70" and package type.

5. Device Operations

5.1 Programming

Each Flash die must be programmed independently due to the nature of the dual die stack.

5.2 Simultaneous Die Operation

The user may only access one Flash die of the dual die stack at a time via its respective Chip Select.

5.3 Sequential Reads

Sequential reads are not supported across the end of the first Flash die to the beginning of the second. If the user desires to sequentially read across the two die, data must be read out of the first die via CS1# and then read out of the second die via CS2#.

5.4 Sector/Bulk Erase

A sector erase command must be issued for sectors in each Flash die separately. Full device Bulk Erase via a single command is not supported due to the nature of the dual die stack. A Bulk Erase command must be issued for each die.

5.5 Status Registers

Each Flash die of the dual die stack is managed by its own Status Registers. Reads and updates to the Status Registers must be managed separately. It is recommended that Status Register control bit settings of each die are kept identical to maintain consistency when switching between die.

5.6 Configuration Register

Each Flash die of the dual die stack is managed by its own Configuration Register. Updates to the Configuration Register control bits must be managed separately. It is recommended that Configuration Register control bit settings of each die are kept identical to maintain consistency when switching between die.

5.7 Bank Address Register

It is recommended that the Bank Address Register bit settings of each die are kept identical to maintain consistency when switching between die.

5.8 ASP Register, Password Register, PPB Lock Register, PPB Access Register, DYB Access Register, DDR Data Learning Registers

It is recommended that the bit settings for all of the above registers in each die are kept identical to maintain consistency when switching between die.

5.9 Block Protection

Each Flash die of the dual die stack will maintain its own Block Protection. Updates to the TBPROT and BPNV bits of each die must be managed separately. By default, each die is configured to be protected starting at the top (highest address) of each array, but no address range is protected. It is recommended that the Block Protection settings of each die are kept identical to maintain consistency when switching between die. In addition, any update to the FREEZE bit must be managed separately for each die. If the FREEZE bit is set to a logic 1, it cannot be cleared to a logic 0 until a power-on-reset is executed on each die that has the FREEZE bit set to 1.

6. Read Identification (RDID)

The Read Identification (RDID) command outputs the one-byte manufacturer identification, followed by the two-byte device identification and the bytes for the Common Flash Interface (CFI) tables. Each die of the FL01GS dual die stack will have identical identification data as the FL512S die, with the exception of the CFI data at byte 27h, as shown in [Table 6.1](#).

Table 6.1 Product Group CFI Device Geometry Definition

Byte	Data	Description
27h	1Bh	Device Size = 2^N byte

7. RESET#

Note that the hardware RESET# input (pin 3) is bonded out and active for the S70FL01GS device. For applications that do NOT require use of the RESET# pin, it is recommended to not use RESET# for PCB routing channels that would cause the RESET# signal to be asserted Low (V_{IL}). Doing so will cause the device to reset to standby state. The RESET# signal has an internal pull-up resistor and may be left unconnected in the host system if not used.

8. Versatile I/O Power Supply (V_{IO})

Note that the Versatile I/O (V_{IO}) power supply (pin 14) is not supported and pin 14 is RFU (Reserved for Future Use) in the standard configuration of the S70FL01GS device. Contact your local sales office to confirm availability with the V_{IO} feature enabled.

9. DC Characteristics

This section summarizes the DC Characteristics of the device.

Table 9.1 DC Characteristics

Symbol	Parameter	Test Conditions	Min	Typ (1)	Max	Unit
V_{IL}	Input Low Voltage		-0.5		$0.2 \times V_{CC}$	V
V_{IH}	Input High Voltage		$0.7 \times V_{CC}$		$V_{CC} + 0.4$	V
V_{OL}	Output Low Voltage	$I_{OL} = 1.6 \text{ mA}$, $V_{CC} = V_{CC} \text{ min}$			$0.15 \times V_{CC}$	V
V_{OH}	Output High Voltage	$I_{OH} = -0.1 \text{ mA}$	$0.85 \times V_{CC}$			V
I_{LI}	Input Leakage Current	$V_{CC} = V_{CC} \text{ Max}$, $V_{IN} = V_{IH} \text{ or } V_{IL}$			± 4	μA
I_{LO}	Output Leakage Current	$V_{CC} = V_{CC} \text{ Max}$, $V_{IN} = V_{IH} \text{ or } V_{IL}$			± 4	μA
I_{CC1}	Active Power Supply Current (READ)	Serial SDR @ 50 MHz Serial SDR @ 133 MHz Quad SDR @ 80 MHz Quad SDR @ 104 MHz Quad DDR @ 66 MHz Outputs unconnected during read data return (2)			18 36 50 61 75	mA
I_{CC2}	Active Power Supply Current (Page Program)	$CS\# = V_{CC}$			100	mA
I_{CC3}	Active Power Supply Current (WRR)	$CS\# = V_{CC}$			100	mA
I_{CC4}	Active Power Supply Current (SE)	$CS\# = V_{CC}$			100	mA
I_{CC5}	Active Power Supply Current (BE) (3)	$CS\# = V_{CC}$			100	mA
I_{SB} (Industrial)	Standby Current	RESET#, $CS\# = V_{CC}$; SI, SCK = V_{CC} or V_{SS} , Industrial Temp		70	200	μA

Notes:

1. Typical values are at $T_{AI} = 25^\circ\text{C}$ and $V_{CC} = 3\text{V}$.
2. Output switching current is not included.
3. Bulk Erase is on a per-die basis, not for the whole device.

10. AC Test Conditions

Figure 10.1 Input, Output, and Timing Reference Levels

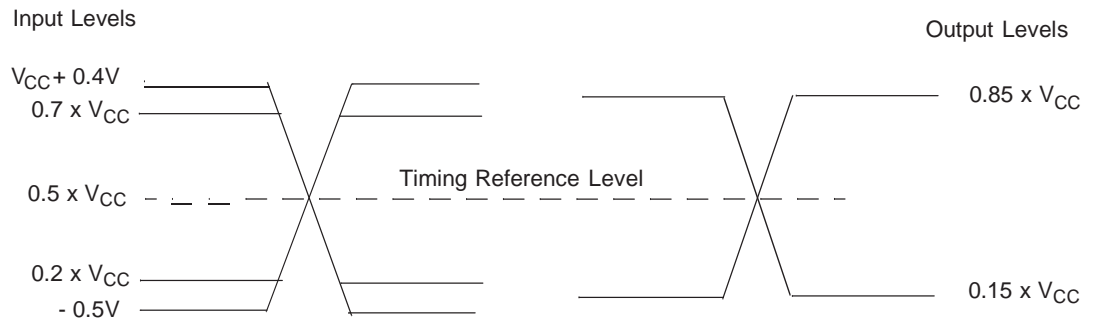

Figure 10.2 Test Setup

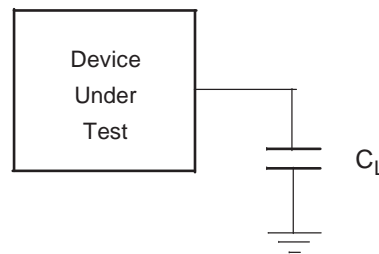

Table 10.1 AC Measurement Conditions

Symbol	Parameter	Min	Max	Unit
C_L	Load Capacitance	30 15 (4)		pF
	Input Rise and Fall Times		2.4	ns
	Input Pulse Voltage	0.2 x V_{CC} to 0.8 V_{CC}		V
	Input Timing Ref Voltage	0.5 V_{CC}		V
	Output Timing Ref Voltage	0.5 V_{CC}		V

Notes:

1. Output High-Z is defined as the point where data is no longer driven.
2. Input slew rate: 1.5 V/ns.
3. AC characteristics tables assume clock and data signals have the same slew rate (slope).
4. DDR Operation.

11. SDR AC Characteristics

Table 11.1 SDR AC Characteristics (Single Die Package, $V_{CC} = 2.7V$ to $3.6V$)

Symbol	Parameter	Min	Typ	Max	Unit
$F_{SCK,R}$	SCK Clock Frequency for READ and 4READ instructions	DC		50	MHz
$F_{SCK,C}$	SCK Clock Frequency for single commands (4)	DC		133	MHz
$F_{SCK,C}$	SCK Clock Frequency for the following dual and quad commands: DOR, 4DOR, QOR, 4QOR, DIOR, 4DIOR, QIOR, 4QIOR	DC		104	MHz
$F_{SCK,QPP}$	SCK Clock Frequency for the QPP, 4QPP commands	DC		80	MHz
P_{SCK}	SCK Clock Period	$1/F_{SCK}$		∞	
t_{WH}, t_{CH}	Clock High Time (5)	45% P_{SCK}			ns
t_{WL}, t_{CL}	Clock Low Time (5)	45% P_{SCK}			ns
t_{CRT}, t_{CLCH}	Clock Rise Time (slew rate)	0.1			V/ns
t_{CFT}, t_{CHCL}	Clock Fall Time (slew rate)	0.1			V/ns
t_{CS} (7)	CS# High Time (Read Instructions) CS# High Time (Program/Erase)	10 50			ns
t_{CSS}	CS# Active Setup Time (relative to SCK)	3			ns
t_{CSH}	CS# Active Hold Time (relative to SCK)	3		3000 (6)	ns
t_{SU}	Data in Setup Time	3			ns
t_{HD}	Data in Hold Time	2			ns
t_V	Clock Low to Output Valid	0		8.0 (2) 7.65 (3) 6.5 (4)	ns
t_{HO}	Output Hold Time	2			ns
t_{DIS}	Output Disable Time	0		8	ns
t_{WPS}	WP# Setup Time	20 (1)			ns
t_{WPH}	WP# Hold Time	100 (1)			ns
t_{HLCH}	HOLD# Active Setup Time (relative to SCK)	3			ns
t_{CHHH}	HOLD# Active Hold Time (relative to SCK)	3			ns
t_{HHCH}	HOLD# Non Active Setup Time (relative to SCK)	3			ns
t_{CHHL}	HOLD# Non Active Hold Time (relative to SCK)	3			ns
t_{HZ}	HOLD# enable to Output Invalid			8	ns
t_{LZ}	HOLD# disable to Output Valid			8	ns

Notes:

1. Only applicable as a constraint for WRR instruction when SRWD is set to a 1.
2. Full V_{CC} range (2.7 - 3.6V) and $CL = 30$ pF.
3. Regulated V_{CC} range (3.0 - 3.6V) and $CL = 30$ pF.
4. Regulated V_{CC} range (3.0 - 3.6V) and $CL = 15$ pF.
5. $\pm 10\%$ duty cycle is supported for frequencies ≤ 50 MHz.
6. Maximum value only applies during Program/Erase Suspend/Resume commands.
7. When switching between die, a minimum time of t_{CS} must be kept between the rising edge of one chip select and the falling edge of the other for operations and data to be valid.

11.1 DDR AC Characteristics

Table 11.2 DDR AC Characteristics 66 MHz Operation

Symbol	Parameter	Min	Typ	Max	Unit
$f_{SCK, R}$	SCK Clock Frequency for DDR READ instruction	DC		66	MHz
$P_{SCK, R}$	SCK Clock Period for DDR READ instruction	15		∞	ns
t_{crt}	Clock Rise Time (slew rate)	1.5			V/ns
t_{cft}	Clock Fall Time (slew rate)	1.5			V/ns
t_{WH}, t_{CH}	Clock High Time	45% P_{SCK}			ns
t_{WL}, t_{CL}	Clock Low Time	45% P_{SCK}			ns
t_{CS}	CS# High Time (Read Instructions)	10			ns
t_{CSS}	CS# Active Setup Time (relative to SCK)	3			ns
t_{CSH}	CS# Active Hold Time (relative to SCK)	3			ns
t_{SU}	IO in Setup Time	2		3000 (2)	ns
t_{HD}	IO in Hold Time	2			ns
t_V	Clock Low to Output Valid	0		6.5 (1)	ns
t_{HO}	Output Hold Time	0			ns
t_{DIS}	Output Disable Time			8	ns
t_{LZ}	Clock to Output Low Impedance	0		8	ns
t_{HTU}	Time uncertainty due to variation in V_{IH}			50	ps
t_{LTU}	Time uncertainty due to variation in V_{IL}			50	ps
t_{IO_skew}	First IO to last IO data valid time			600	ps
t_{OFT}	Output rise time given 3V swing and 2.0 V/ns slew			1.5	ns
t_{IOFT}	Output fall time given 3V swing and 2.0 V/ns slew			1.5	ns
ΔT_V	Clock to data valid jitter			25	ps

Notes:

1. Regulated V_{CC} range (3.0 - 3.6V) and $CL = 15$ pF.
2. Maximum value only applies during Program/Erase Suspend/Resume commands.

11.2 Capacitance Characteristics

Table 11.3 Capacitance

	Parameter	Test Conditions	Min	Max	Unit
C_{IN}	Input Capacitance (applies to SCK, CS#1, CS#2, RESET#)	1 MHz		8	pF
C_{OUT}	Output Capacitance (applies to All I/O)	1 MHz		8	pF

Notes:

1. For more information on capacitance, please consult the IBIS models.
2. Capacitance values correspond to single die FL512S only.

12. SOIC 16 Physical Diagram

12.1 503016 — 16-pin Wide Plastic Small Outline Package (300-mil Body Width)

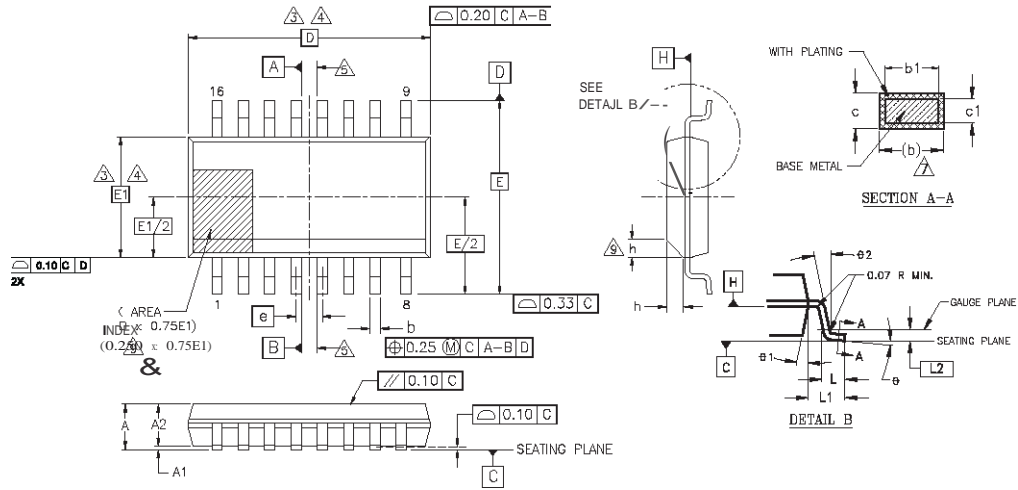

PACKAGE	S03016 Onct.)		S03016(mm)	
JEDEC	MS-013(E)M		MS-013(E)M	
SYMBOL	MIN	MAX	MIN	MAX
A	0.093	0.104	2.35	2.65
A1	0.004	0.012	0.10	0.30
A2	0.081	0.104	2.05	2.56
b	0.012	0.020	0.31	0.51
b1	0.011	0.019	0.27	0.48
c	0.006	0.013	0.20	0.33
c1	0.008	0.012	0.20	0.30
D	0.408BSC		10.30BSC	
E	0.406BSC		10.3DBSC	
E1	0.295BSC		7.50 BSC	
e	0.050BSC		1.27BSC	
L	0.016	0.050	DAD	1.27
L1	0.056 REF		UOREF	
L2	0.010 BSC		0.25BSC	
N	16		16	
h	0.10	0.30	0.25	0.75
II	0'	8'	0'	8'
&1	5'	15'	5'	15'
III	0'	—	0'	—

NOTES:

- ALL DIMENSIONS ARE IN BOTH INCHES AND MILLIMETERS.
- DIMENSIONING AND TOLERANCING PER ASME Y14.5M- 1994.
 DIMENSION D DOES NOT INCLUDE MOLD FLASH, PROTRUSIONS OR GATE BURRS. MOLD FLASH, PROTRUSIONS OR GATE BURRS SHALL NOT EXCEED 0.15 mm PER END. DIMENSION E1 DOES NOT INCLUDE INTERLEAD FLASH OR PROTRUSION INTERLEAD FLASH OR PROTRUSION SHALL NOT EXCEED 0.25 mm PER SIDE. D AND E1 DIMENSIONS ARE DETERMINED AT DATUM H.
 THE PACKAGE TOP MAY BE SMALLER THAN THE PACKAGE BOTTOM. DIMENSIONS D AND E1 ARE DETERMINED AT THE OUTMOST EXTREMES OF THE PLASTIC BODY EXCLUSIVE OF MOLD FLASH, TIE BAR BURRS, GATE BURRS AND INTERLEAD FLASH, BUT INCLUDING ANY MISMATCH BETWEEN THE TOP AND BOTTOM OF THE PLASTIC BODY.
 DATUMS A AND B TO BE DETERMINED AT DATUM H.
- "N" IS THE MAXIMUM NUMBER OF TERMINAL POSITIONS FOR THE SPECIFIED PACKAGE LENGTH.
 THE DIMENSIONS APPLY TO THE FLAT SECTION OF THE LEAD BETWEEN 0.10 TO 0.25 mm FROM THE LEAD TIP.
 DIMENSION "b" DOES NOT INCLUDE DAMBAR PROTRUSION. ALLOWABLE DAMBAR PROTRUSION SHALL BE 0.10 mm TOTAL IN EXCESS OF THE "b" DIMENSION AT MAXIMUM MATERIAL CONDITION. THE DAMBAR CANNOT BE LOCATED ON THE LOWER RADIUS OF THE LEAD FOOT.
 THIS CHAMFER FEATURE IS OPTIONAL. IF IT IS NOT PRESENT, THEN A PIN 1 IDENTIFIER MUST BE LOCATED WITHIN THE INDEX AREA INDICATED.
- LEAD COPLANARITY SHALL BE WITHIN 0.10 mm AS MEASURED FROM THE SEATING PLANE.



13. Revision History

Section	Description
Revision 01 (November 6, 2012)	
	Initial release
Revision 02 (April 25, 2013)	
Global	Data sheet designation updated from Advance Information to Preliminary
DC Characteristics	DC Characteristics table: changed Max value of I_{LI} , I_{LO} , I_{CC1} , and I_{SB}

Colophon

The products described in this document are designed, developed and manufactured as contemplated for general use, including without limitation, ordinary industrial use, general office use, personal use, and household use, but are not designed, developed and manufactured as contemplated (1) for any use that includes fatal risks or dangers that, unless extremely high safety is secured, could have a serious effect to the public, and could lead directly to death, personal injury, severe physical damage or other loss (i.e., nuclear reaction control in nuclear facility, aircraft flight control, air traffic control, mass transport control, medical life support system, missile launch control in weapon system), or (2) for any use where chance of failure is intolerable (i.e., submersible repeater and artificial satellite). Please note that Spansion will not be liable to you and/or any third party for any claims or damages arising in connection with above-mentioned uses of the products. Any semiconductor devices have an inherent chance of failure. You must protect against injury, damage or loss from such failures by incorporating safety design measures into your facility and equipment such as redundancy, fire protection, and prevention of over-current levels and other abnormal operating conditions. If any products described in this document represent goods or technologies subject to certain restrictions on export under the Foreign Exchange and Foreign Trade Law of Japan, the US Export Administration Regulations or the applicable laws of any other country, the prior authorization by the respective government entity will be required for export of those products.

Trademarks and Notice

The contents of this document are subject to change without notice. This document may contain information on a Spansion product under development by Spansion. Spansion reserves the right to change or discontinue work on any product without notice. The information in this document is provided as is without warranty or guarantee of any kind as to its accuracy, completeness, operability, fitness for particular purpose, merchantability, non-infringement of third-party rights, or any other warranty, express, implied, or statutory. Spansion assumes no liability for any damages of any kind arising out of the use of the information in this document.

Copyright © 2012-2013 Spansion Inc. All rights reserved. Spansion®, the Spansion logo, MirrorBit®, MirrorBit® Eclipse™, ORNAND™ and combinations thereof, are trademarks and registered trademarks of Spansion LLC in the United States and other countries. Other names used are for informational purposes only and may be trademarks of their respective owners.

AMEYA360

Components Supply Platform

Authorized Distribution Brand :



Website :

Welcome to visit www.ameya360.com

Contact Us :

➤ Address :

401 Building No.5, JiuGe Business Center, Lane 2301, Yishan Rd
Minhang District, Shanghai , China

➤ Sales :

Direct +86 (21) 6401-6692

Email amall@ameya360.com

QQ 800077892

Skype [ameyasales1](#) [ameyasales2](#)

➤ Customer Service :

Email service@ameya360.com

➤ Partnership :

Tel +86 (21) 64016692-8333

Email mkt@ameya360.com