

MAX11190

4-Channel, Dual, Simultaneous Sampling, 2.2V to 3.6V, 12-Bit, 3Msps SAR ADC in Tiny 3mm x 3mm TQFN Package

General Description

The MAX11190 is a 4-channel, dual, multiplexed, 12-bit, compact, high-speed, low-power, successive approximation analog-to-digital converter (ADC). This high-performance dual ADC includes high-dynamic range sample-and-holds and a high-speed serial interface. This ADC accepts a full-scale input from 0V to the reference voltage.

The device features two dual, single-ended analog inputs connected to two ADC cores using 2:1 MUXs. The device also includes a separate supply input for data interface and dedicated inputs for reference voltage.

This device operates from a 2.2V to 3.6V supply and consumes only 10.5mW at 3Msps. The device includes full power-down mode and fast wake-up for optimal power management and a high-speed 3-wire serial interface. The 3-wire serial interface directly connects to SPI, QSPI™, and MICROWIRE® devices without external logic. Each of the two internal ADCs has its own dedicated DOUTA/DOUTB for faster data communication.

Excellent dynamic performance, low voltage, low power, ease of use, and small package size make this converter ideal for simultaneous data-acquisition applications, and for other applications that demand low power consumption and minimal space.

The device is available in a 3mm x 3mm, 16-pin TQFN package and operates over the -40°C to +125°C temperature range.

Applications

- Motor Control
- Simultaneous Data Acquisition
- Medical Instrumentation
- Process Control

Ordering Information appears at end of data sheet.

For related parts and recommended products to use with this part, refer to www.maximintegrated.com/MAX11190.related.

QSPI is a trademark of Motorola, Inc.

MICROWIRE is a registered trademark of National Semiconductor Corporation

Benefits and Features

- Integration and Packaging Save Space
 - Simultaneous Sampling
 - Dual, 4-Channel, Single-Ended 12-Bit Resolution ADC (2 x 2)
 - 16-Pin, 3mm x 3mm TQFN Package
- Excellent Performance Ideal for Motor Control Applications
 - 72dB SNR
 - 3Msps Conversion Rate without Pipeline Delay
 - External Reference Inputs
 - Wide -40°C to +125°C Operation
- Low Power Design Simplifies Power-Supply Requirements
 - Very Low Power Consumption at 5µA/ksps
 - 10.5mW at 3Msps
 - 2.2V to 3.6V Supply Voltage
 - 2.6µA Power-Down Current
- Dual SPI Ports Simplifies System Design
 - SPI-/QSPI-/MICROWIRE-Compatible Serial Interface with Two DOUTA/DOUTB Pins
 - Dedicated Digital Output Supply Allows Serial Interface to Directly Connect to 1.5V, 1.8V, 2.5V, or 3V Digital Systems

Functional Diagram

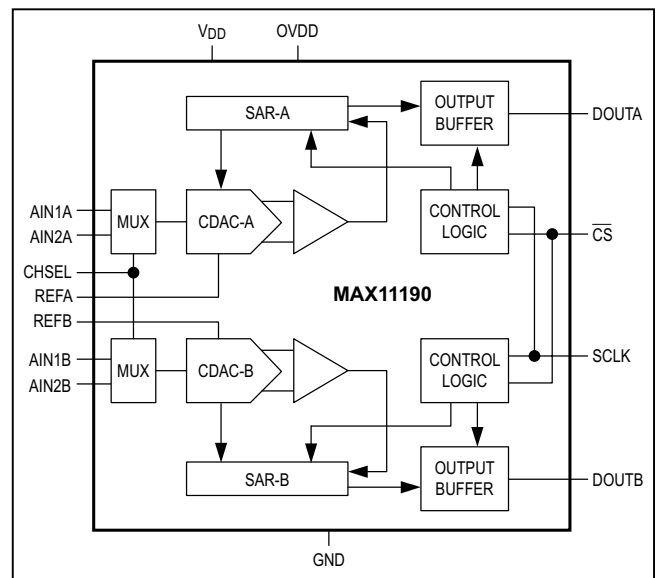

TABLE OF CONTENTS

General Description	1
Applications	1
Benefits and Features	1
Functional Diagram	1
Absolute Maximum Ratings	4
Package Thermal Characteristics	4
Electrical Characteristics	4
Typical Operating Characteristics	8
Pin Configuration	10
Pin Description	10
Typical Operating Circuit	11
Detailed Description	12
Serial Interface	12
Analog Input	12
ADC Transfer Function	13
Operation Modes	13
Power-Down Mode	13
Entering Power-Down Mode	13
Exiting Power-Down Mode	14
Supply Current vs. Sampling Rate	14
Dual-Channel Operation	15
14-Cycle Conversion Mode	15
Applications Information	15
Layout, Grounding, and Bypassing	15
Choosing an Input Amplifier	15
Choosing a Reference	16
Definitions	17
Integral Nonlinearity	17
Differential Nonlinearity	17
Offset Error	17
Gain Error	17
Aperture Jitter	17
Aperture Delay	17
Aperture Delay Matching	17
Signal-To-Noise Ratio (SNR)	17
Signal-To-Noise Ratio and Distortion (SINAD)	17
Total Harmonic Distortion	17
Spurious-Free Dynamic Range (SFDR)	17

TABLE OF CONTENTS (continued)

Full-Power Bandwidth	17
Full-Linear Bandwidth	17
Intermodulation Distortion	17
Ordering Information	18
Chip Information	18
Package Information	18
Revision History	19

LIST OF FIGURES

Figure 1. Interface Signals for Maximum Throughput	7
Figure 2. Setup Time After SCLK Falling Edge	7
Figure 3. Hold Time After SCLK Falling Edge	7
Figure 4. SCLK Falling Edge DOUTA/DOUTB Three-State	7
Figure 5. Analog Input Circuit	12
Figure 6. Normal Mode	13
Figure 7. Entering Power-Down Mode	13
Figure 8. Exiting Power-Down Mode	14
Figure 9. ADC Transfer Function	14
Figure 10. Supply Current vs. Sample Rate (Normal Operating Mode)	14
Figure 11. Supply Current vs. Sample Rate (Device Powered Down Between Conversions)	14
Figure 12. Channel Select Timing Diagram	15
Figure 13. 14-Clock Cycle Operation	15
Figure 14. Typical Application Circuit	16

MAX11190

4-Channel, Dual, Simultaneous Sampling, 2.2V to 3.6V, 12-Bit, 3Msps SAR ADC in Tiny 3mm x 3mm TQFN Package

Absolute Maximum Ratings

V_{DD} to GND -0.3V to +4V
 AIN1A, AIN2A to GND -0.3V to the lower of (V_{DD} + 0.3V) and +4.0V
 REFA, OVDD to GND -0.3V to the lower of (V_{DD} + 0.3V) and +4.0V
 AIN1B, AIN2B to GND -0.3V to the lower of (V_{DD} + 0.3V) and +4.0V
 REFB to GND -0.3V to the lower of (V_{DD} + 0.3V) and +4.0V
 CS, SCLK to GND -0.3V to the lower of (V_{OVDD} + 0.3V) and +4.0V
 CHSEL to GND -0.3V to the lower of (V_{OVDD} + 0.3V) and +4.0V
 DOUTA to GND -0.3V to the lower of (V_{OVDD} + 0.3V) and +4.0V
 DOUTB to GND -0.3V to the lower of (V_{OVDD} + 0.3V) and +4.0V

Multilayer Board Max Power Dissipation (T_A = +70°C)
 TQFN (derate 20.8mW/°C above +70°C) 1667mW
 Operating Temperature Range -40°C to +125°C
 Storage Temperature Range -65°C to +150°C
 Lead Temperature (soldering, 10s) +300°C
 Soldering Temperature (reflow) +260°C

Stresses beyond those listed under "Absolute Maximum Ratings" may cause permanent damage to the device. These are stress ratings only, and functional operation of the device at these or any other conditions beyond those indicated in the operational sections of the specifications is not implied. Exposure to absolute maximum rating conditions for extended periods may affect device reliability.

Package Thermal Characteristics (Note 1)

TQFN

Junction-to-Ambient Thermal Resistance (θ_{JA}) 48°C/W
 Junction-to-Case Thermal Resistance (θ_{JC}) 10°C/W

Note 1: Package thermal resistances were obtained using the method described in JEDEC specification JESD51-7, using a four-layer board. For detailed information on package thermal considerations, refer to www.maximintegrated.com/thermal-tutorial.

Electrical Characteristics

(V_{DD} = +2.2V to +3.6V, REFA = REFB = V_{DD}, OVDD = V_{DD}, unless otherwise noted. f_{SCLK} = 48MHz, 3Msps, 50% duty cycle. Reference pins are independent, C_{DOUTA/DOUTB} = 10pF. T_A = -40°C to 125°C, unless otherwise noted. Typical values are at T_A = +25°C.) (Note 2)

PARAMETER	SYMBOL	CONDITIONS	MIN	TYP	MAX	UNITS
DC ACCURACY						
Resolution		12 bit	12			Bits
Integral Nonlinearity	INL				±1	LSB
Differential Nonlinearity	DNL	No missing codes over temperature			±1	LSB
Offset Error				±1	±4.0	LSB
Gain Error		Excluding offset and reference errors		±1	±4.0	LSB
Total Unadjusted Error	TUE			±1.5		LSB
Channel-to-Channel Offset Matching				±0.3		LSB
Channel-to-Channel Gain Matching				±0.3		LSB
DYNAMIC PERFORMANCE						
Signal-to-Noise Plus Distortion (Note 3)	SINAD	f _{IN} = 1MHz	70	72		dB
Signal-to-Noise Ratio	SNR	f _{IN} = 1MHz	70.5	72		dB
Total Harmonic Distortion	THD	f _{IN} = 1MHz		-85	-75	dB
Spurious-Free Dynamic Range	SFDR	f _{IN} = 1MHz	76	85		dB
Intermodulation Distortion	IMD	f _{IN1} = 1.0003MHz, f _{IN2} = 0.99955MHz		-84		dB
Full-Power Bandwidth		-3dB point		40		MHz
Full-Linear Bandwidth		SINAD > 68dB		2.5		MHz
Small-Signal Bandwidth				45		MHz
Crosstalk		Channel to channel		-90		dB

Electrical Characteristics (continued)

($V_{DD} = +2.2V$ to $+3.6V$, $REFA = REFB = V_{DD}$, $OVDD = V_{DD}$, unless otherwise noted. $f_{SCLK} = 48MHz$, 3Msps, 50% duty cycle. Reference pins are independent, $C_{DOUTA/DOUTB} = 10pF$. $T_A = -40^{\circ}C$ to $125^{\circ}C$, unless otherwise noted. Typical values are at $T_A = +25^{\circ}C$.) (Note 2)

PARAMETER	SYMBOL	CONDITIONS	MIN	TYP	MAX	UNITS
CONVERSION RATE						
Throughput		16 cycles	0.03		3	MspS
Conversion Time		13 cycles	260			ns
Acquisition Time	t_{ACQ}	Track time = 2.5 cycles	52			ns
Aperture Delay		From \overline{CS} falling edge		4		ns
Aperture Delay Matching				150		ps
Aperture Jitter				15		ps
Serial-Clock Frequency	f_{CLK}		0.48		48	MHz
ANALOG INPUT (AIN1A, AIN2A, AIN1B, and AIN2B)						
Input Voltage Range	V_{INA}	AIN1A and AIN2A pins	0		V_{REFA}	V
	V_{INB}	AIN1B and AIN2B pins	0		V_{REFB}	V
Input Leakage Current	I_{ILA}			0.002	± 1	μA
Input Capacitance	$C_{AIN_}$	Track		20		pF
		Hold		4		
EXTERNAL REFERENCE (REFA and REFB)						
Input Voltage Range	V_{REFA} V_{REFB}		1		$V_{DD} + 0.05$	V
Input Leakage Current	I_{ILR}	Conversion stopped		0.005	± 1	μA
Input Capacitance	C_{REFA} C_{REFB}			5		pF
DIGITAL INPUTS (SCLK, \overline{CS}, CHSEL)						
Input High Voltage	V_{IH}		$0.75 \times V_{OVDD}$			V
Input Low Voltage	V_{IL}		$0.25 \times V_{OVDD}$			V
Input Hysteresis	V_{HYST}		$0.15 \times V_{OVDD}$			$\%OVDD/V_{DD}$
Input Leakage Current	I_{IL}	Inputs at 0V or V_{OVDD}		0.001	± 1	μA
Input Capacitance	C_{IN}			2		pF
DIGITAL OUTPUT (DOUTA and DOUTB)						
Output High Voltage	V_{OH}	$I_{SOURCE} = 1mA$	$0.85 \times V_{OVDD}$			V
Output Low Voltage	V_{OL}	$I_{SINK} = 5mA$	$0.15 \times V_{OVDD}$			V
Three-State Leakage Current	I_{OL}				± 1.0	μA
Three-State Output Capacitance (Without Pad Metal)	C_{OUT}			5		pF

Electrical Characteristics (continued)

($V_{DD} = +2.2V$ to $+3.6V$, $REFA = REFB = V_{DD}$, $OVDD = V_{DD}$, unless otherwise noted. $f_{SCLK} = 48MHz$, 3Msps, 50% duty cycle. Reference pins are independent, $C_{DOUTA/DOUTB} = 10pF$. $T_A = -40^{\circ}C$ to $125^{\circ}C$, unless otherwise noted. Typical values are at $T_A = +25^{\circ}C$.) (Note 2)

PARAMETER	SYMBOL	CONDITIONS	MIN	TYP	MAX	UNITS
POWER SUPPLY						
Positive Supply Voltage	V_{DD}	V_{DD} pin	2.2		3.6	V
Digital I/O Supply Voltage	V_{OVDD}	$OVDD$ pin	1.5		V_{DD}	V
Power-Down Current	I_{PD}	Leakage only, per supply pin		2.6	10	μA
Positive Supply Current (Full Power Mode)	I_{DD}	$f_{SAMPLE} = 3Msps$, $V_{AIN} = 0V$, both ADCs			6.8	mA
Positive Supply Current (Full Power Mode), No Clock	I_{DD}	$f_{SAMPLE} = 3Msps$, $V_{DD} = +3V$, both ADCs		3.9		mA
Line Rejection	PSR	$V_{DD} = +2.2V$ to $+3.6V$, $V_{REF} = 2.2V$		0.7		LSB/V
TIMING CHARACTERISTICS						
Quiet Time	t_Q	(Note 4)	4			ns
\overline{CS} Pulse Width	t_1	(Note 4)	10			ns
\overline{CS} Fall to SCLK Setup	t_2	(Note 4)	5			ns
\overline{CS} Falling until DOUTA/DOUTB Three-State Disabled	t_3	(Note 4)	1			ns
Data Access Time After SCLK Falling Edge	t_4	$V_{OVDD} = 2.2V$ to $3.6V$ $V_{OVDD} = 1.5V$ to $2.2V$			15 16.5	ns
SCLK Pulse-Width Low	t_5	Percentage of clock period (Note 4)	40		60	%
SCLK Pulse-Width High	t_6	Percentage of clock period (Note 4)	40		60	%
Data Hold Time from SCLK Falling Edge	t_7	Figure 3 (Note 4)	5			ns
SCLK Falling until DOUTA/DOUTB Three-States	t_8	Figure 4 (Note 4)	2.5		14	ns
T-Power Up		1 conversion cycle (Note 4)			1	Cycle

Note 2: Limits are 100% tested at $T_A = +25^{\circ}C$. Limits over the operating temperature range and relevant supply voltage range are guaranteed by design and characterization, unless otherwise noted.

Note 3: All timing specifications given are with a 10pF capacitor.

Note 4: Guaranteed by design in characterization; not production tested.

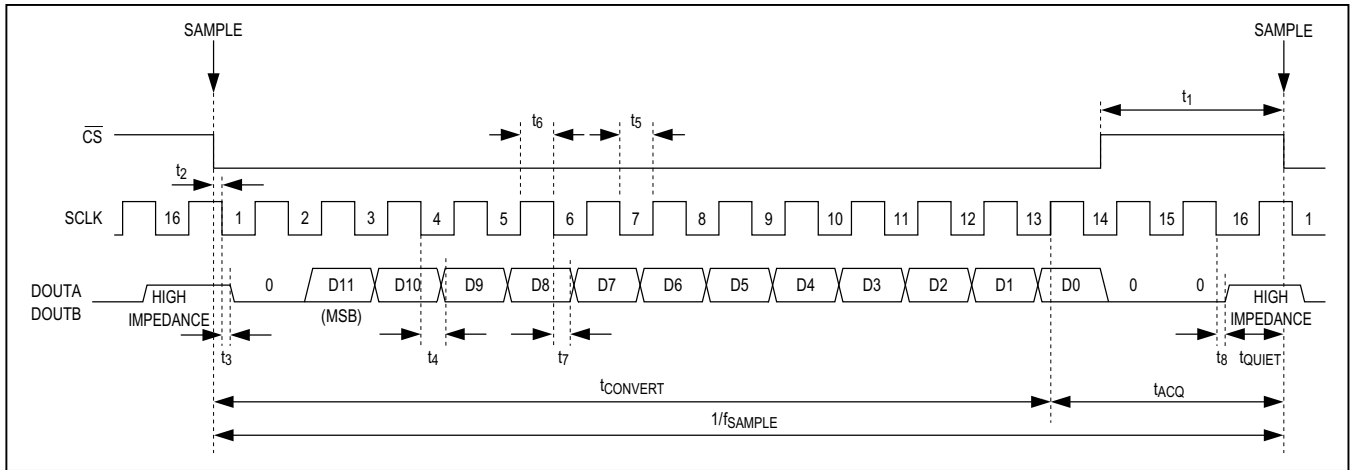

Figure 1. Interface Signals for Maximum Throughput

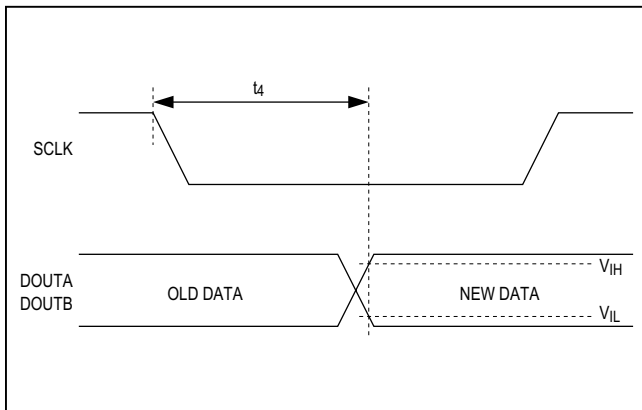

Figure 2. Setup Time After SCLK Falling Edge

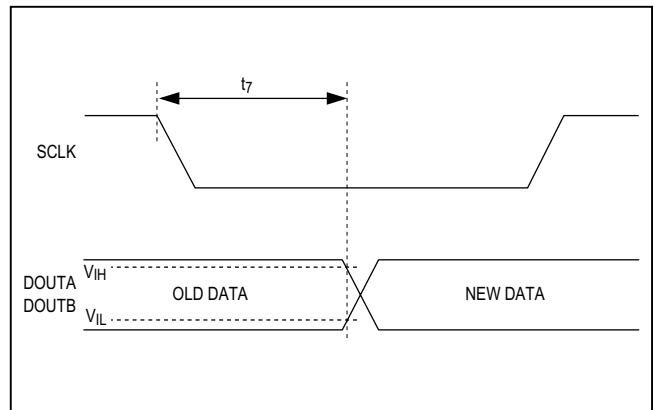

Figure 3. Hold Time After SCLK Falling Edge

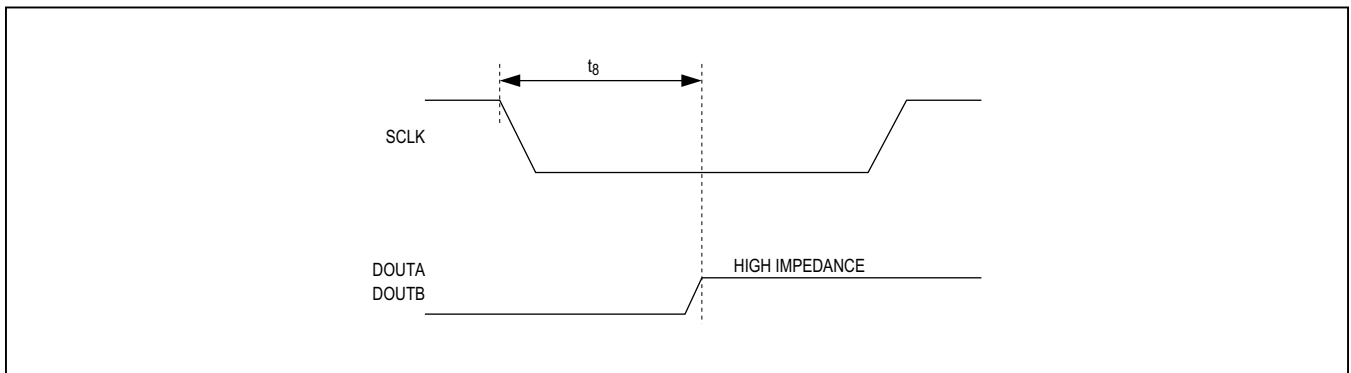
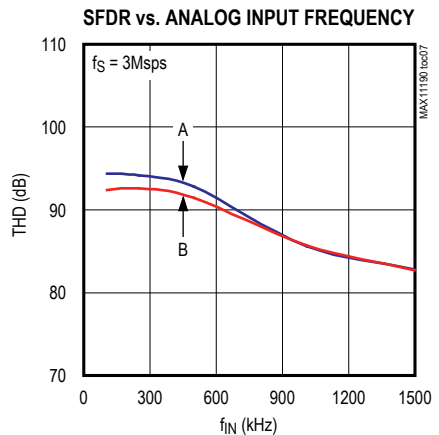
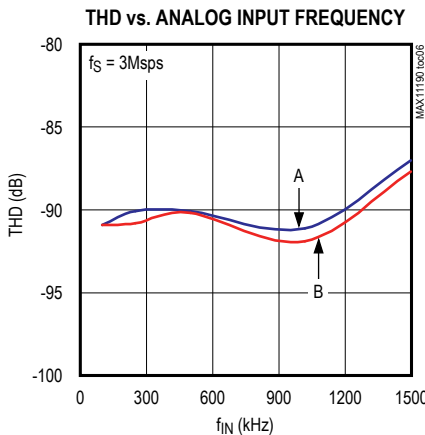
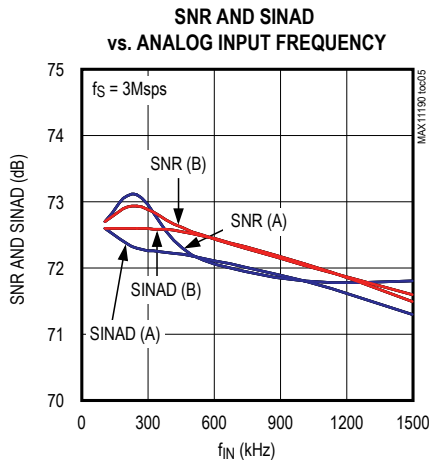
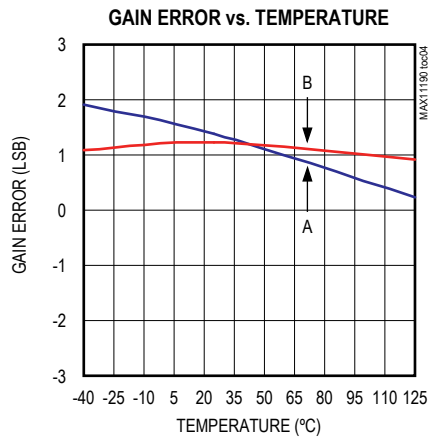
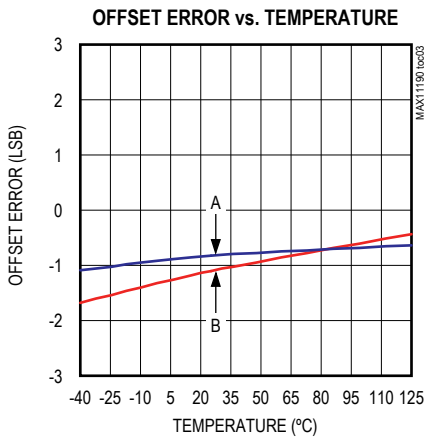
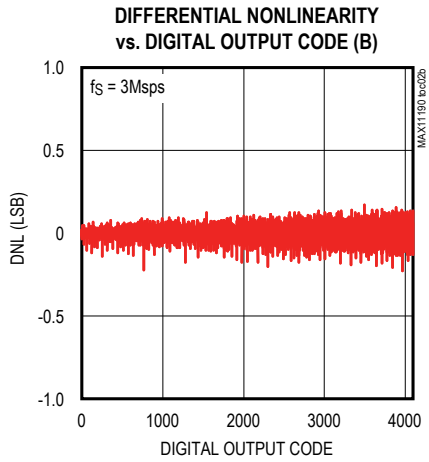
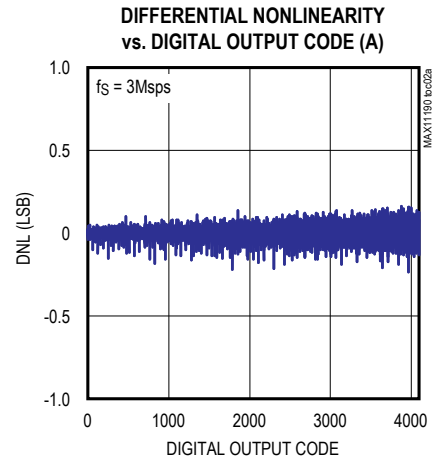
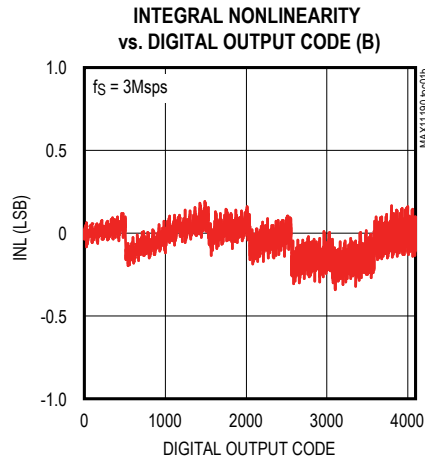
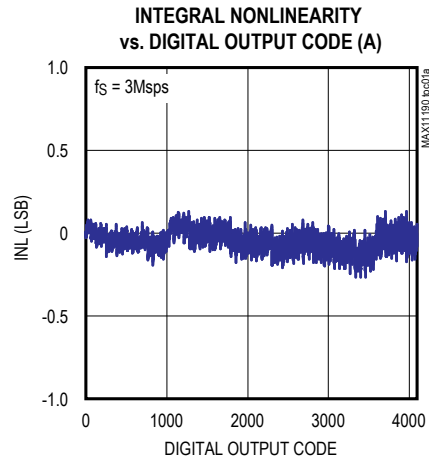
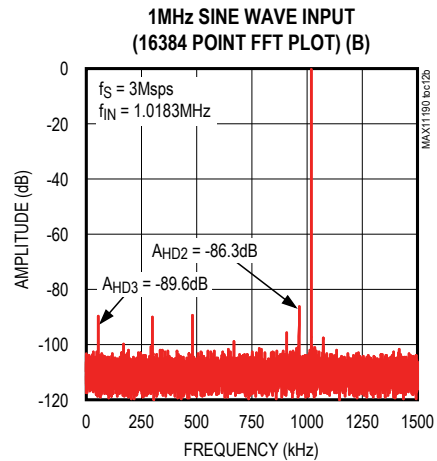
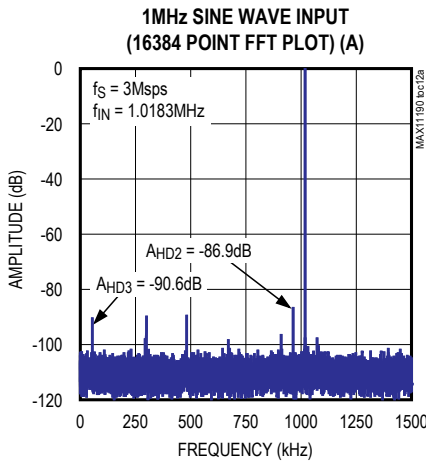
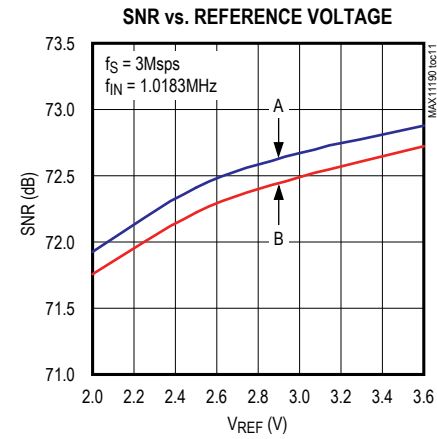
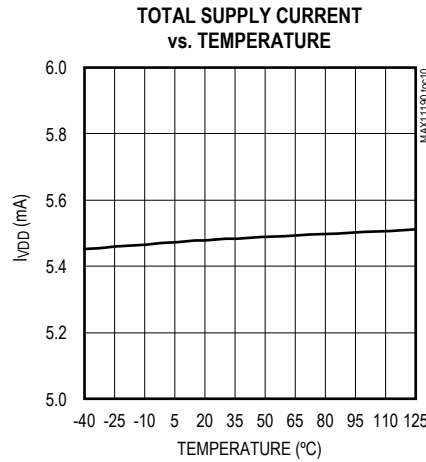
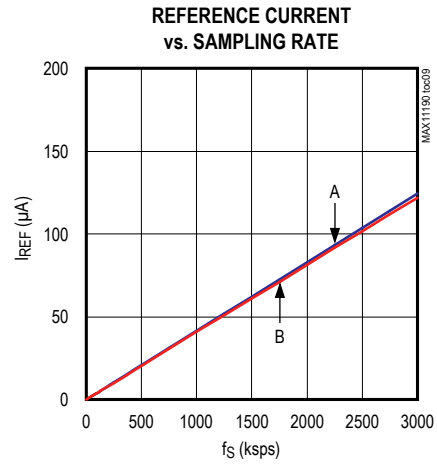
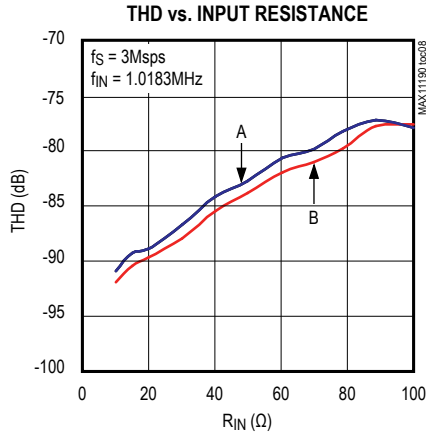

Figure 4. SCLK Falling Edge DOUTA/DOUTB Three-State

Typical Operating Characteristics



Typical Operating Characteristics (continued)



MAX11190

4-Channel, Dual, Simultaneous Sampling,
2.2V to 3.6V, 12-Bit, 3Msps SAR ADC in Tiny
3mm x 3mm TQFN Package

Pin Configuration

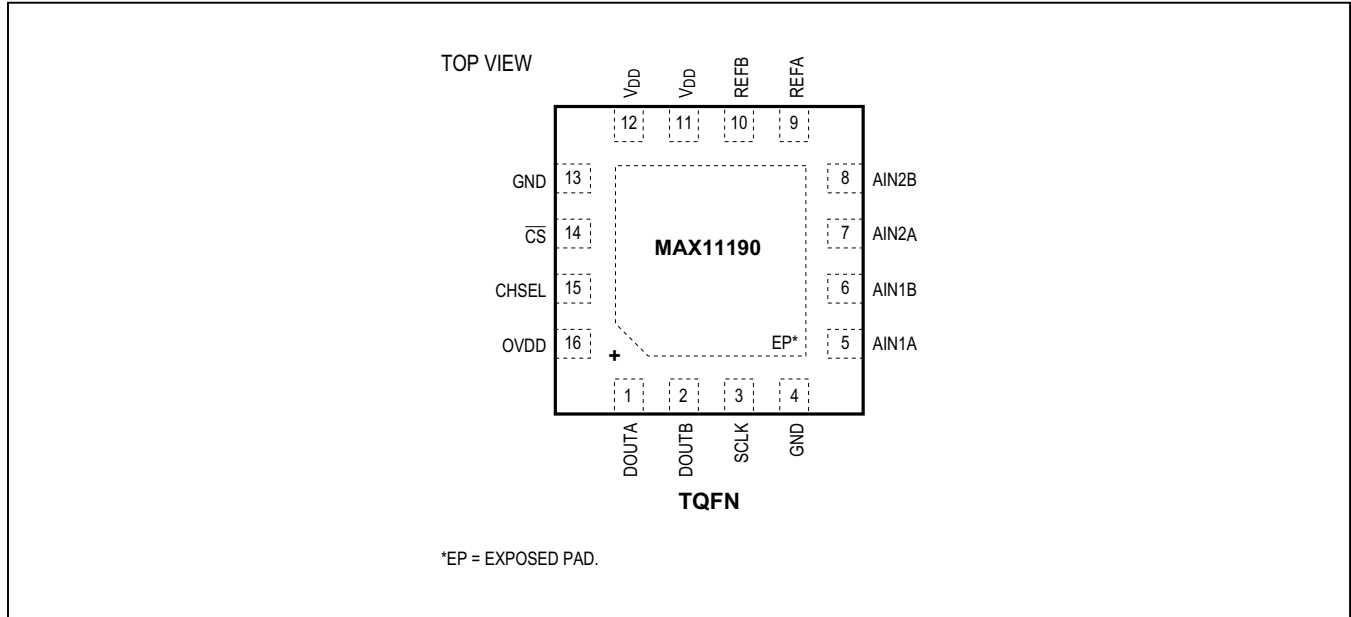

Pin Description

PIN	NAME	FUNCTION
1	DOUTA	Serial-Data Output of ADC A. DOUTA changes state on SCLK's falling edge.
2	DOUTB	Serial-Data Output of ADC B. DOUTB changes state on SCLK's falling edge.
3	SCLK	Serial-Clock Input. SCLK drives the conversion process and clocks data out.
4	GND	Ground. This pin must connect to a solid ground plane.
5	AIN1A	Channel 1 of ADC A
6	AIN1B	Channel 1 of ADC B
7	AIN2A	Channel 2 of ADC A
8	AIN2B	Channel 2 of ADC B
9	REFA	Reference Pin for ADC A
10	REFB	Reference Pin for ADC B
11, 12	V _{DD}	Positive Supply Voltage
13	GND	Ground. This pin must connect to a solid ground plane.
14	\overline{CS}	Chip Select (Active-Low). Initiates power-up and acquisition on the falling edge.
15	CHSEL	Channel Select Pin Referring to AIN1A/AIN1B and AIN2A/AIN2B. Set CHSEL low to select AIN1A/AIN1B for conversion.
16	OVDD	Digital I/O Supply Voltage (\overline{CS} , CHSEL, DOUTA, DOUTB, SCLK). Bypass to GND with a 4.7 μ F ceramic capacitor.
—	EP	Exposed pad, internally connected to ground. Connect to a solid ground plane.

Typical Operating Circuit

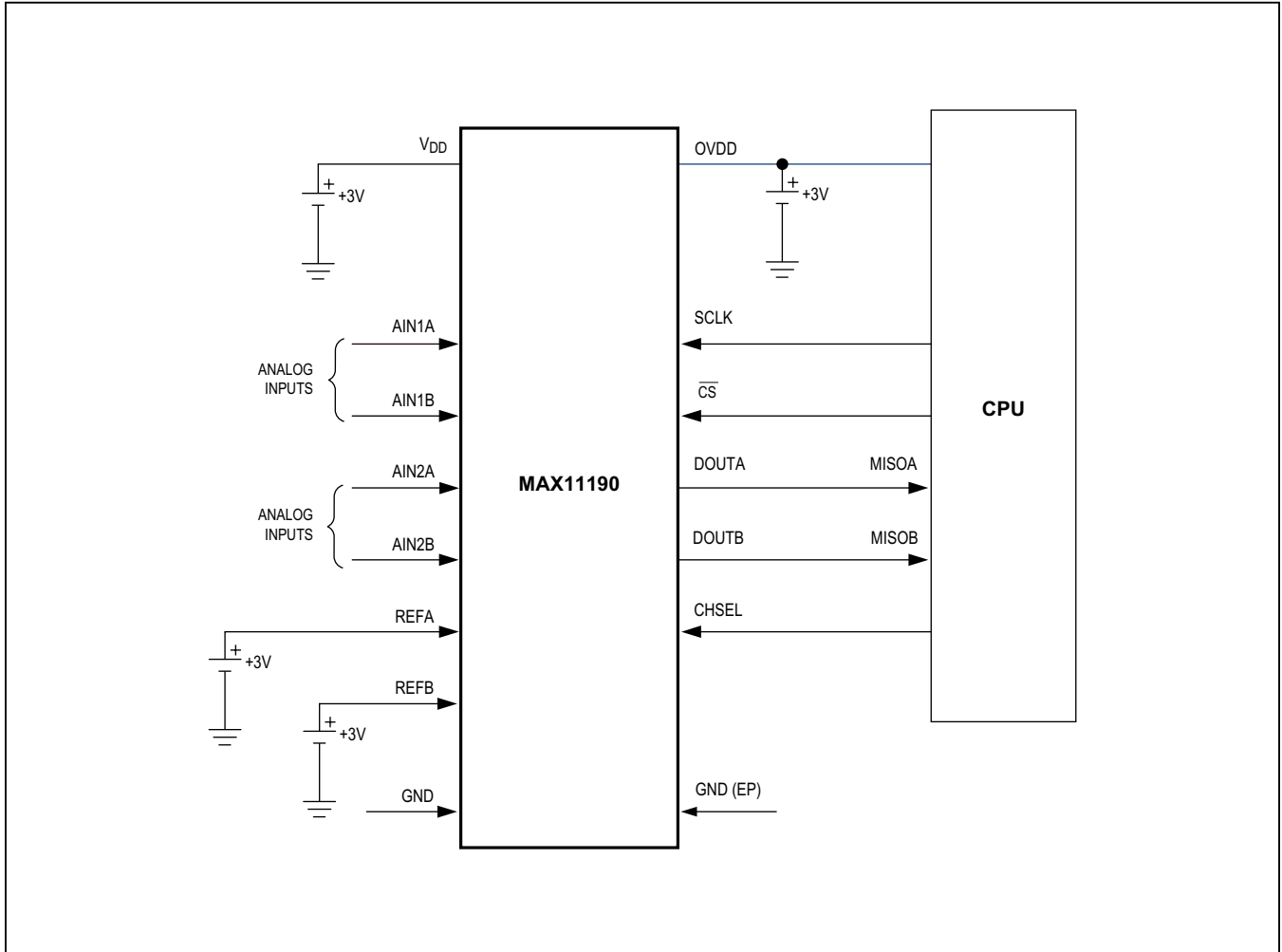

Detailed Description

The MAX11190 is a 3Msps, 12-bit, low-power, single-supply, dual, multiplexed simultaneous-sampling ADC. The device operates from a 2.2V to 3.6V supply and consumes only 16.4mW ($V_{DD} = 3V$)/10.5mW ($V_{DD} = 2.2V$) at 3Msps. This device is capable of sampling at full rate when driven by 48MHz. The MAX11190 provides a separate digital supply input (OVDD) to power the digital interface enabling communication with 1.5V, 1.8V, 2.5V, or 3V digital systems.

The conversion results for each of the two integrated ADCs appear at DOUTA and DOUTB, MSB first, with a leading zero followed by the 12-bit results followed by two trailing zeros. See [Figure 1](#).

Each ADC core has an independent reference input. The input signal range for analog inputs is defined as 0V to V_{REF} (V_{REF} of respective core) with respect to GND.

This device includes a power-down feature allowing minimized power consumption at 5 μ A/ksp for lower throughput rates. The wake-up and power-down feature is controlled by using the SPI interface as described in the [Operation Modes](#) section.

Serial Interface

The MAX11190 features a 3-wire serial interface that directly connects to SPI, QSPI, and MICROWIRE devices without external logic—DOUTA and DOUTB need to be received by the host at the same time. [Figure 1](#) shows the interface signals for a single conversion frame to achieve maximum throughput.

The falling edge of \overline{CS} defines the sampling instant. Once \overline{CS} transitions low, the external clock signal (SCLK) controls the conversion.

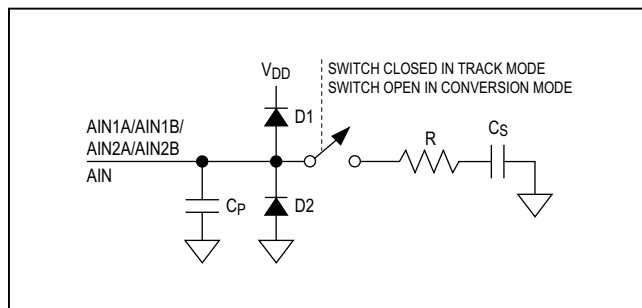

Figure 5. Analog Input Circuit

Each of the two SAR cores of this device successively extracts binary-weighted bits in every clock cycle. The MSB appears on the data bus during the 2nd clock cycle with a delay outlined in the timing specifications. All extracted data bits appear successively on the data bus with the LSB appearing during the 13th clock cycle for 12-bit operation. The serial data stream of conversion bits is preceded by a leading zero and succeeded by trailing zeros. The data outputs (DOUTA and DOUTB) go into high-impedance state during the 16th clock cycle.

To sustain the maximum sample rate, all devices have to be resampled immediately after the 16th clock cycle. For lower sample rates, the \overline{CS} falling edge can be delayed leaving DOUTA/DOUTB in a high-impedance condition. Pull \overline{CS} high after the 10th SCLK falling edge (see the [Operation Modes](#) section).

Analog Input

The MAX11190 produces digital outputs that correspond to the analog input voltages within the specified operating range of 0 to V_{REF} .

[Figure 5](#) shows an equivalent circuit for the analog input AIN1A/AIN1B/AIN2A/AIN2B. Internal protection diodes D1/D2 confine the analog input voltage within the power rails (V_{DD} , GND). The analog input voltage can swing from $V_{GND} - 0.3V$ to $V_{DD} + 0.3V$ without damaging the device.

The electric load presented to the external stage driving the analog input varies depending on which mode the ADC is in: track mode vs. conversion mode. In track mode, the internal sampling capacitor, C_S (16pF), must be charged through the resistor, R (50 Ω), to the input voltage. For faithful sampling of the input, the capacitor voltage on \overline{CS} has to settle to the required accuracy during the track time.

The source impedance of the external driving stage in conjunction with the sampling switch resistance affects the settling performance. The THD vs. Input Resistance graph in the [Typical Operating Characteristics](#) shows THD sensitivity as a function of the signal source impedance. Keep the source impedance at a minimum for high-dynamic performance applications. Use a high-performance op amp, such as the MAX4430, to drive the analog input, thereby decoupling the signal source and the ADC.

While the ADC is in conversion mode, the sampling switch is open presenting a pin capacitance, C_P ($C_P = 5pF$), to the driving stage. See the [Applications Information](#) section for information on choosing an appropriate buffer for the ADC.

ADC Transfer Function

The output format is straight binary. The code transitions midway between successive integer LSB values such as 0.5 LSB, 1.5 LSB, etc. The LSB size is $V_{REF}/2^{12}$. The ideal transfer characteristic is shown in [Figure 9](#).

Operation Modes

The IC offers two modes of operation: normal mode and power-down mode. The logic state of the \overline{CS} signal during a conversion activates these modes. The power-down mode can be used to optimize power dissipation with respect to sample rate.

Normal Mode

In normal mode, the device is powered up at all times, thereby achieving its maximum throughput rates. [Figure 6](#) shows the timing diagram of this device in normal mode. The falling edge of \overline{CS} samples the analog input signal, starts a conversion, and frames the serial-data transfer.

To remain in normal mode, keep \overline{CS} low until the falling edge of the 10th SCLK cycle. Pulling \overline{CS} high after the 10th SCLK falling edge keeps the part in normal mode. However, pulling \overline{CS} high before the 10th SCLK falling edge terminates the conversion, both DOUTA/DOUTBs go into high-impedance mode, and the device enters power-down mode. See [Figure 7](#).

Power-Down Mode

In power-down mode, all bias circuitry is shut down drawing typically only 2.6 μ A of leakage current. To save power, put the device in power-down mode between conversions. Using the power-down mode between conversions is ideal for saving power when sampling the analog input infrequently.

Entering Power-Down Mode

To enter power-down mode, drive \overline{CS} high between the 2nd and 10th falling edges of SCLK (see [Figure 7](#)). By pulling \overline{CS} high, the current conversion terminates and both DOUTA/DOUTB enter high impedance.

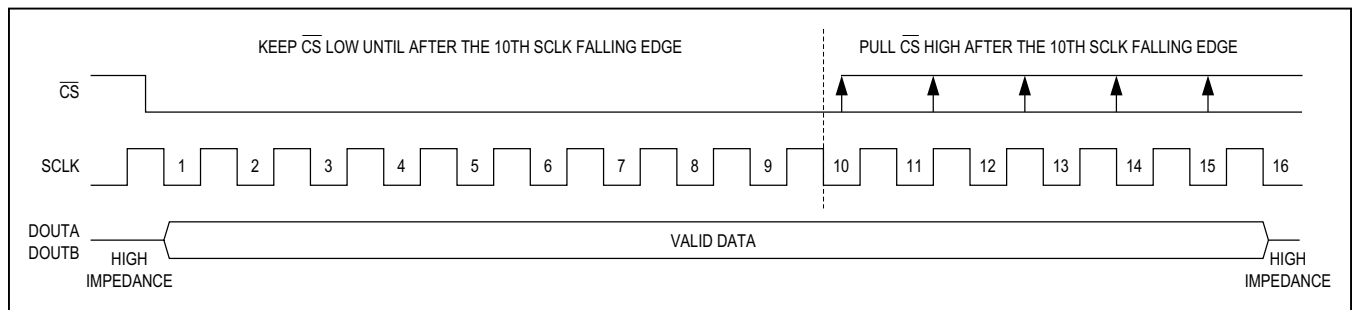

Figure 6. Normal Mode

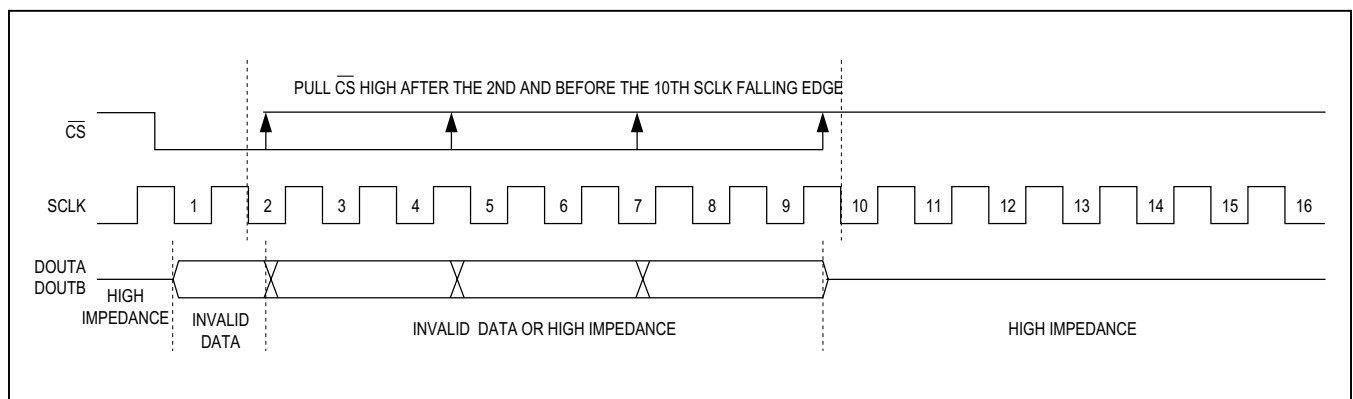

Figure 7. Entering Power-Down Mode

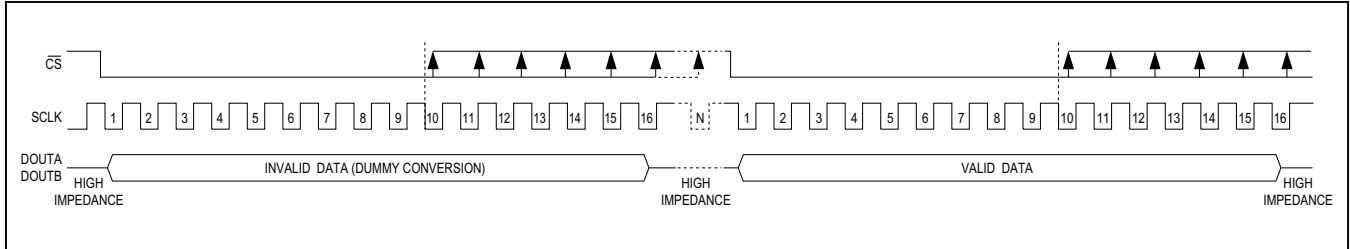

Figure 8. Exiting Power-Down Mode

Exiting Power-Down Mode

To exit power-down mode, implement one dummy conversion by driving CS low for at least 10 clock cycles (see Figure 8). The data on DOUTA/DOUTB is invalid during this dummy conversion. The first conversion following the dummy cycle contains a valid conversion result.

The power-up time equals the duration of the dummy cycle, and is dependent on the clock frequency. The power-up time for this device (48MHz SCLK) is 333ns.

Supply Current vs. Sampling Rate

For applications requiring lower throughput rates, the user can reduce the clock frequency (f_{SCLK}) to lower the sample rate. Figure 10 shows the typical supply current (I_{VDD}) as a function of sample rate (f_S) for the device. The part operates in normal mode and is never powered down.

The user can also power down the ADC between conversions by using power-down mode. Figure 11 shows this device as the sample rate is reduced, the device remains in the power-down state longer and the average supply current (I_{VDD}) drops accordingly.

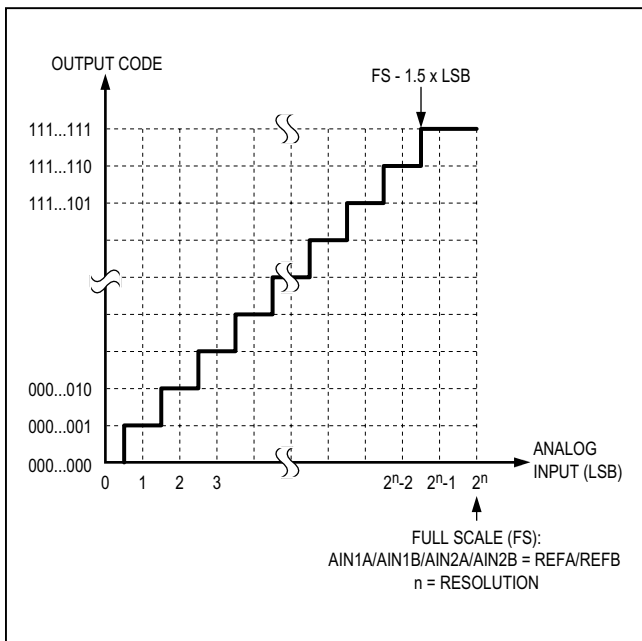

Figure 9. ADC Transfer Function

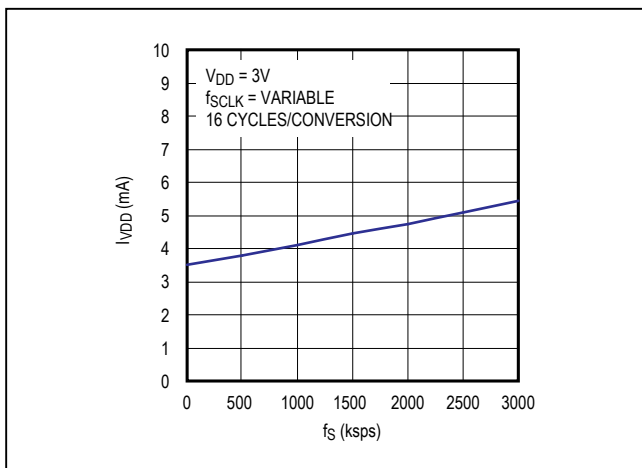

Figure 10. Supply Current vs. Sample Rate (Normal Operating Mode)

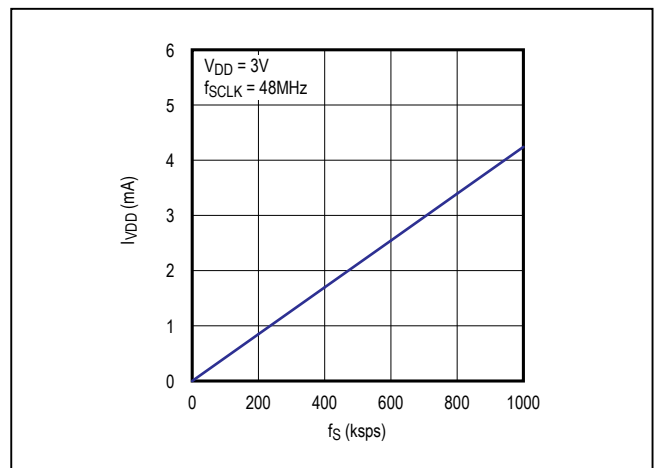

Figure 11. Supply Current vs. Sample Rate (Device Powered Down Between Conversions)

Dual-Channel Operation

The MAX11190 features dual simultaneous-sampling ADCs each with two multiplexed channels. This device uses a channel-select (CHSEL) input to select between analog input AIN1A/AIN1B (CHSEL = 0) or AIN2A/AIN2B (CHSEL = 1). As shown in Figure 12, the CHSEL signal is required to change between the 2nd and 12th clock cycle within a regular conversion to guarantee proper switching between channels.

14-Cycle Conversion Mode

The IC can operate with 14 cycles per conversion. Figure 13 shows the corresponding timing diagram. Observe that DOUTA/DOUTB does not go into high-impedance mode. Also, observe that t_{ACQ} needs to be sufficiently long to guarantee proper settling of the analog input voltage. See the *Electrical Characteristics* table for t_{ACQ} requirements and the *Analog Input* section for a description of the analog inputs.

Applications Information

Layout, Grounding, and Bypassing

For best performance, use PCBs with a solid ground plane. Ensure that digital and analog signal lines are separated from each other. Do not run analog and digital (especially clock) lines parallel to one another or digital lines underneath the ADC package. Noise in the V_{DD} power supply, OVDD, and REFA/REFB affects the ADC's performance. Bypass the V_{DD} , OVDD, and REFA/REFB to ground with 0.1 μ F and 10 μ F bypass capacitors. Minimize capacitor lead and trace lengths for best supply-noise rejection.

Choosing an Input Amplifier

It is important to match the settling time of the input amplifier to the acquisition time of the ADC. The conversion results are accurate when the ADC samples the input signal for an interval longer than the input signal's worst-case settling time. By definition, settling time is the interval

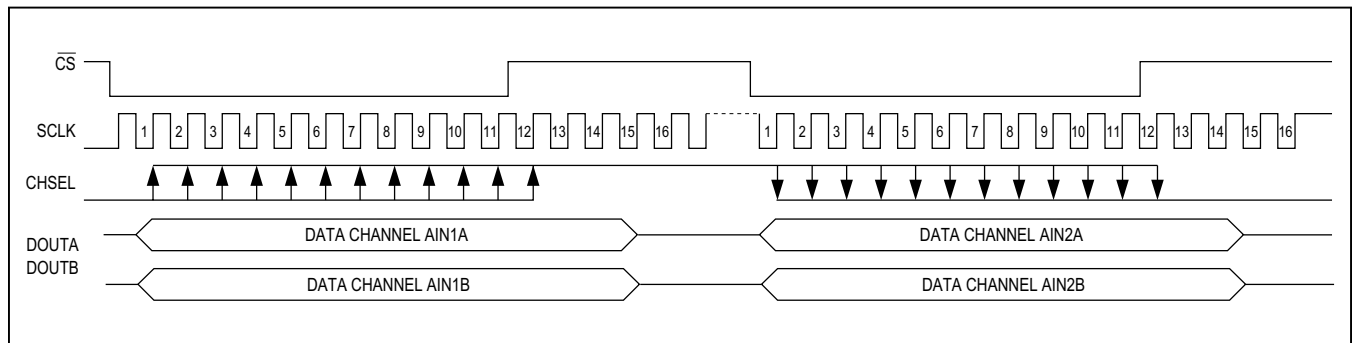

Figure 12. Channel Select Timing Diagram

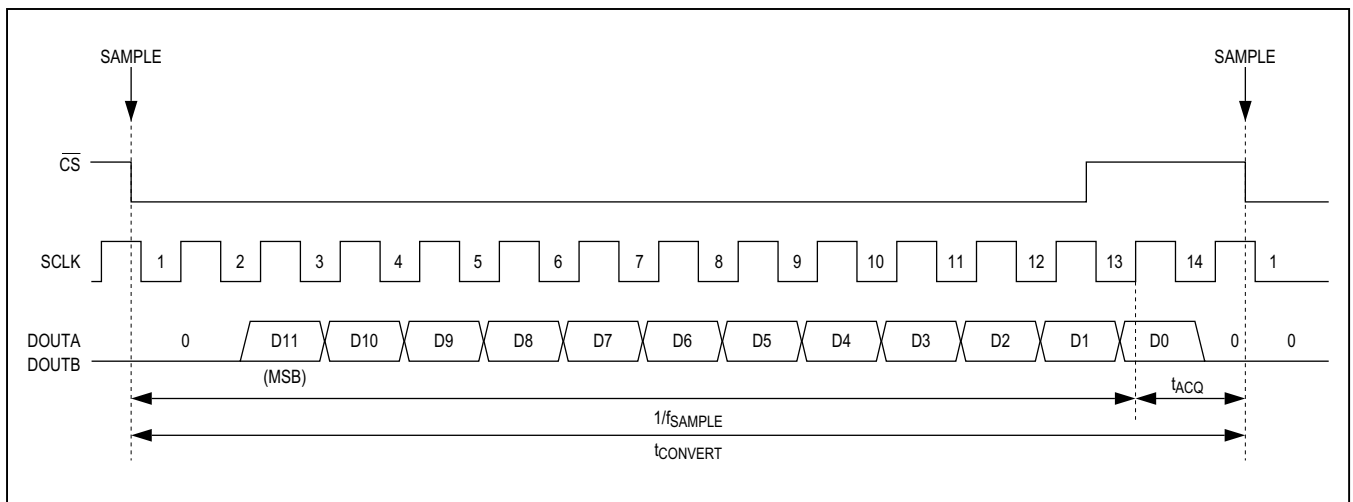

Figure 13. 14-Clock Cycle Operation

between the application of an input voltage step and the point at which the output signal reaches and stays within a given error band centered on the resulting steady-state amplifier output level. The ADC input sampling capacitor charges during the sampling cycle, referred to as the acquisition period. During this acquisition period, the settling time is affected by the input resistance and the input sampling capacitance. This error can be estimated by looking at the settling of an RC time constant using the input capacitance and the source impedance over the acquisition time period.

Figure 14 shows a typical application circuit. The MAX4430, offering a settling time of 37ns at 16 bits, is an excellent choice for this application. See the THD

vs. Input Resistance graph in the *Typical Operating Characteristics*.

Choosing a Reference

For devices using an external reference, the choice of the reference determines the output accuracy of the ADC. An ideal voltage reference provides a perfect initial accuracy and maintains the reference voltage independent of changes in load current, temperature, and time. Considerations in selecting a reference include initial voltage accuracy, temperature drift, current source, sink capability, quiescent current, and noise. Figure 14 shows a typical application circuit using the MAX6126 to provide the reference voltage. The MAX6033 and MAX6043 are also excellent choices.

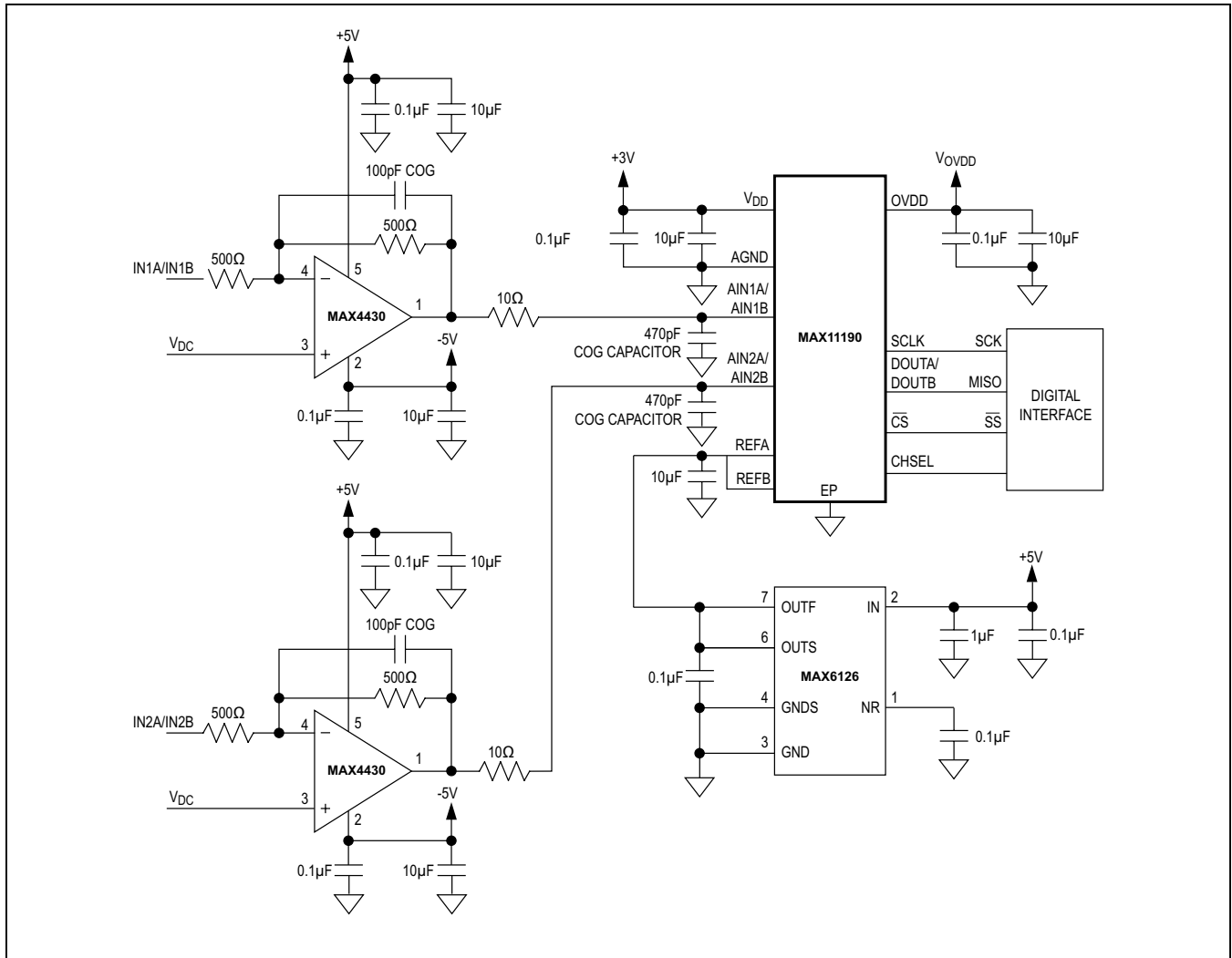

Figure 14. Typical Application Circuit

Definitions

Integral Nonlinearity

Integral nonlinearity (INL) is the deviation of the values on an actual transfer function from a straight line. For these devices, the straight line is a line drawn between the end points of the transfer function after offset and gain errors are nulled.

Differential Nonlinearity

Differential nonlinearity (DNL) is the difference between an actual step width and the ideal value of 1 LSB. A DNL error specification of ± 1 LSB or less guarantees no missing codes and a monotonic transfer function.

Offset Error

Offset error is the deviation of the first code transition (00 . . . 000) to (00 . . . 001) from the ideal, that is, AGND + 0.5 LSB.

Gain Error

Gain error is the deviation of the last code transition (111 . . . 110) to (111 . . . 111) from the ideal after adjusting for the offset error, that is, $V_{REF} - 1.5$ LSB.

Aperture Jitter

Aperture jitter (t_{AJ}) is the sample-to-sample variation in the time between the samples.

Aperture Delay

Aperture delay (t_{AD}) is the time between the falling edge of the sampling clock and the instant when an actual sample is taken.

Aperture Delay Matching

Aperture delay (t_{ADM}) is the difference between the aperture delay between channel A and B measured at the falling edge of the sampling clock for the sample taken from the identical analog input.

Signal-To-Noise Ratio (SNR)

SNR is a dynamic figure of merit that indicates the converter's noise performance. For a waveform perfectly reconstructed from digital samples, the theoretical maximum SNR is the ratio of the full-scale analog input (RMS value) to the RMS quantization error (residual error). The ideal, theoretical minimum analog-to-digital noise is caused by quantization error only and results directly from the ADC's resolution (N bits):

$$\text{SNR (dB) (MAX)} = (6.02 \times N + 1.76) \text{ (dB)}$$

In reality, there are other noise sources such as thermal noise, reference noise, and clock jitter that also degrade SNR. SNR is computed by taking the ratio of the RMS

signal to the RMS noise. RMS noise includes all spectral components to the Nyquist frequency excluding the fundamental, the first five harmonics, and the DC offset.

Signal-To-Noise Ratio and Distortion (SINAD)

SINAD is a dynamic figure of merit that indicates the converter's noise and distortion performance. SINAD is computed by taking the ratio of the RMS signal to the RMS noise plus distortion. RMS noise plus distortion includes all spectral components to the Nyquist frequency excluding the fundamental and the DC offset:

$$\text{SINAD (dB)} = 20 \times \log \left[\frac{\text{SIGNAL}_{\text{RMS}}}{(\text{NOISE} + \text{DISTORTION})_{\text{RMS}}} \right]$$

Total Harmonic Distortion

Total harmonic distortion (THD) is the ratio of the RMS sum of the first five harmonics of the input signal to the fundamental itself. This is expressed as:

$$\text{THD} = 20 \times \log \left(\frac{\sqrt{V_2^2 + V_3^2 + V_4^2 + V_5^2}}{V_1} \right)$$

where V_1 is the fundamental amplitude and V_2 – V_5 are the amplitudes of the 2nd- through 5th-order harmonics.

Spurious-Free Dynamic Range (SFDR)

SFDR is a dynamic figure of merit that indicates the lowest usable input signal amplitude. SFDR is the ratio of the RMS amplitude of the fundamental (maximum signal component) to the RMS value of the next largest spurious component, excluding DC offset. SFDR is specified in decibels with respect to the carrier (dBc).

Full-Power Bandwidth

Full-power bandwidth is the frequency at which the input signal amplitude attenuates by 3dB for a full-scale input.

Full-Linear Bandwidth

Full-linear bandwidth is the frequency at which the SINAD is equal to a specified value.

Intermodulation Distortion

Any device with nonlinearities creates distortion products when two sine waves at two different frequencies (f_1 and f_2) are applied into the device. Intermodulation distortion (IMD) is the total power of the IM2 to IM5 intermodulation products to the Nyquist frequency relative to the total input power of the two input tones, f_1 and f_2 . The individual input tone levels are at -6dBFS.

MAX11190

4-Channel, Dual, Simultaneous Sampling,
2.2V to 3.6V, 12-Bit, 3Msps SAR ADC in Tiny
3mm x 3mm TQFN Package

Ordering Information

PART	PIN-PACKAGE	BITS	SPEED
MAX11190ATE+	16 TQFN-EP*	12	3Msps

Note: All devices are specified over the -40°C to +125°C operating temperature range.

+Denotes lead(Pb)-free/RoHS-compliant package.

*EP = Exposed pad.

Chip Information

PROCESS: CMOS

Package Information

For the latest package outline information and land patterns (footprints), go to www.maximintegrated.com/packages. Note that a "+", "#", or "-" in the package code indicates RoHS status only. Package drawings may show a different suffix character, but the drawing pertains to the package regardless of RoHS status.

PACKAGE TYPE	PACKAGE CODE	OUTLINE NO.	LAND PATTERN NO.
16 TQFN-EP	T1633MK+5	21-0136	90-0032

MAX11190

4-Channel, Dual, Simultaneous Sampling,
2.2V to 3.6V, 12-Bit, 3Msps SAR ADC in Tiny
3mm x 3mm TQFN Package

Revision History

REVISION NUMBER	REVISION DATE	DESCRIPTION	PAGES CHANGED
0	6/13	Initial release	—
1	2/14	Updated <i>Package Thermal Characteristics</i> and <i>Package Information</i>	4, 18
2	12/14	Updated <i>Benefits and Features</i> section	1

For pricing, delivery, and ordering information, please contact Maxim Direct at 1-888-629-4642, or visit Maxim Integrated's website at www.maximintegrated.com.

Maxim Integrated cannot assume responsibility for use of any circuitry other than circuitry entirely embodied in a Maxim Integrated product. No circuit patent licenses are implied. Maxim Integrated reserves the right to change the circuitry and specifications without notice at any time. The parametric values (min and max limits) shown in the Electrical Characteristics table are guaranteed. Other parametric values quoted in this data sheet are provided for guidance.

AMEYA360

Components Supply Platform

Authorized Distribution Brand :



Website :

Welcome to visit www.ameya360.com

Contact Us :

➤ Address :

401 Building No.5, JiuGe Business Center, Lane 2301, Yishan Rd
Minhang District, Shanghai , China

➤ Sales :

Direct +86 (21) 6401-6692

Email amall@ameya360.com

QQ 800077892

Skype [ameyasales1](#) [ameyasales2](#)

➤ Customer Service :

Email service@ameya360.com

➤ Partnership :

Tel +86 (21) 64016692-8333

Email mkt@ameya360.com