

100-V 350-mA Constant On-Time Buck Switching Regulator

Check for Samples: [LM5008A](#)

FEATURES

- Operating input voltage range: 6V to 95V
- Integrated 100V N-Channel buck switch
- Internal start-up regulator
- No loop compensation required
- Ultra-fast transient response
- On time varies inversely with input voltage
- Operating frequency remains constant with varying line voltage and load current
- Adjustable output voltage from 2.5V
- Highly efficient operation
- Precision internal reference
- Low bias current
- Intelligent current limit
- Thermal shutdown
- VSSOP-8 and WSON-8 (4mm x 4mm) packages

APPLICATIONS

- Non-Isolated Telecommunication Buck Regulator
- Secondary High Voltage Post Regulator
- +42V Automotive Systems

DESCRIPTION

The LM5008A is a functional variant of the LM5008 COT Buck Switching Regulator. The functional differences of the LM5008A are: the minimum input operating voltage is 6 V, the on-time equation is slightly different, and the requirement for a minimum load current is removed.

The LM5008A Step Down Switching Regulator features all of the functions needed to implement a low cost, efficient, Buck bias regulator. This high voltage regulator contains an 100 V N-Channel Buck Switch. The device is easy to implement and is provided in the VSSOP-8 and the thermally enhanced WSON-8 packages. The regulator is based on a control scheme using an ON time inversely proportional to V_{IN} . This feature allows the operating frequency to remain relatively constant. The control scheme requires no loop compensation. An intelligent current limit is implemented with forced OFF time, which is inversely proportional to V_{OUT} . This scheme ensures short circuit control while providing minimum foldback. Other features include: Thermal Shutdown, V_{CC} under-voltage lockout, Gate drive under-voltage lockout, Max Duty Cycle limiter, and a pre-charge switch.

Typical Application, Basic Step-Down Regulator

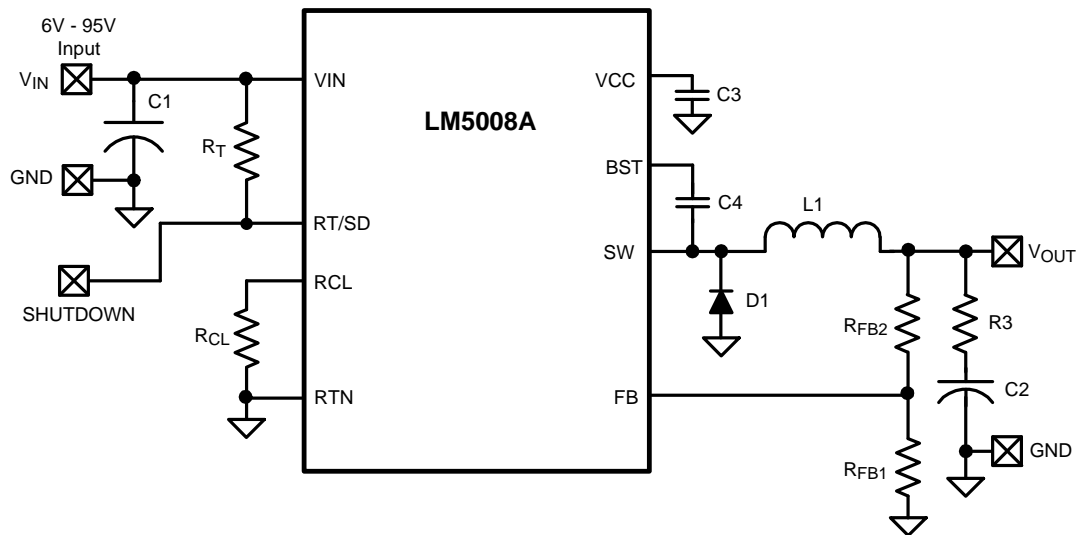

Please be aware that an important notice concerning availability, standard warranty, and use in critical applications of Texas Instruments semiconductor products and disclaimers thereto appears at the end of this data sheet.

All trademarks are the property of their respective owners.

Connection Diagram

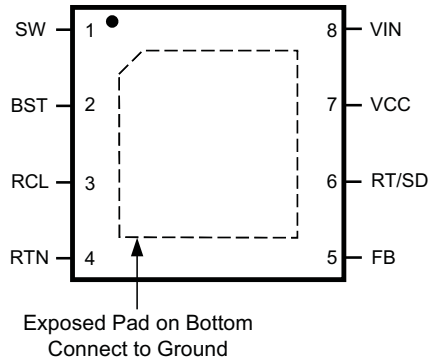

**Figure 1. Top View
8-Lead WSON**

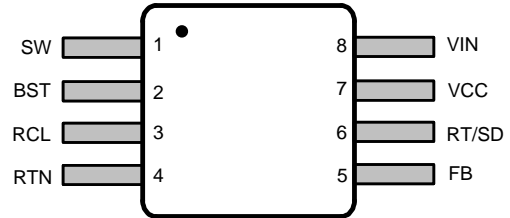

**Figure 2. Top View
8-Lead VSSOP**

Pin Functions

Table 1. Pin Descriptions

Pin	Name	Description	Application Information
1	SW	Switching Node	Power switching node. Connect to the output inductor, re-circulating diode, and bootstrap capacitor.
2	BST	Boost pin (bootstrap capacitor input)	An external capacitor is required between the BST and the SW pins. A 0.01 μF ceramic capacitor is recommended. An internal diode charges the capacitor from V_{CC} during each off-time.
3	RCL	Current Limit OFF time set pin	A resistor between this pin and RTN sets the off-time when current limit is detected. The off-time is preset to 35 μs if $\text{FB} = 0\text{V}$.
4	RTN	Ground pin	Ground for the entire circuit.
5	FB	Feedback input from Regulated Output	This pin is connected to the inverting input of the internal regulation comparator. The regulation threshold is 2.5V.
6	RT/SD	On time set pin	A resistor between this pin and V_{IN} sets the switch on time as a function of V_{IN} . The minimum recommended on time is 400 ns at the maximum input voltage. This pin can be used for remote shutdown.
7	VCC	Output from the internal high voltage series pass regulator	This regulated voltage provides gate drive power for the internal Buck switch. An internal diode is provided between this pin and the BST pin. A local 0.47 μF decoupling capacitor is required. The series pass regulator is current limited to 9 mA.
8	VIN	Input voltage	Input operating range: 6V to 95V.
	EP	Exposed Pad	The exposed pad has no electrical contact. Connect to system ground plane for reduced thermal resistance.



These devices have limited built-in ESD protection. The leads should be shorted together or the device placed in conductive foam during storage or handling to prevent electrostatic damage to the MOS gates.

Absolute Maximum Ratings ⁽¹⁾

V_{IN} to GND	-0.3V to 100V
BST to GND	-0.3V to 114V
SW to GND (Steady State)	-1V
ESD Rating, Human Body Model ⁽²⁾	2kV
BST to V_{CC}	100V
BST to SW	14V
V_{CC} to GND	14V
All Other Inputs to GND	-0.3 to 7V
Lead Temperature (Soldering 4 sec)	260°C
Storage Temperature Range	-55°C to +150°C

- (1) Absolute Maximum Ratings are limits beyond which damage to the device may occur. Operating Ratings are conditions under which operation of the device is intended to be functional. For specifications and test conditions, see the Electrical Characteristics.
- (2) The human body model is a 100pF capacitor discharged through a 1.5k Ω resistor into each pin. The ESD rating for pin 2, pin 7, and pin 8 is 1 kV.

Operating Ratings ⁽¹⁾

V_{IN}	6V to 95V
Operating Junction Temperature	-40°C to + 125°C

- (1) Absolute Maximum Ratings are limits beyond which damage to the device may occur. Operating Ratings are conditions under which operation of the device is intended to be functional. For specifications and test conditions, see the Electrical Characteristics.

Electrical Characteristics

Specifications with standard typeface are for $T_J = 25^\circ\text{C}$, and those with **boldface** type apply over full **Operating Junction Temperature range**. $V_{IN} = 48\text{V}$, unless otherwise stated ⁽¹⁾.

Symbol	Parameter	Conditions	Min	Typ	Max	Unit
VCC Supply						
Vcc Reg	Vcc Regulator Output	$V_{in} = 48\text{V}$	6.6	7	7.4	V
	$V_{in} - V_{cc}$	$6\text{V} < V_{in} < 8.5\text{V}$		100		mV
	Vcc Bypass Threshold	V_{in} Increasing		8.5		V
	Vcc Bypass Hysteresis			300		mV
	Vcc Output Impedance	$V_{in} = 6\text{V}$		100		Ω
		$V_{in} = 10\text{V}$		8.8		Ω
		$V_{in} = 48\text{V}$		0.8		Ω
	Vcc Current Limit	$V_{in} = 48\text{V}$		9.2		mA
	Vcc UVLO	Vcc Increasing		5.3		V
	Vcc UVLO hysteresis			190		mV
	Vcc UVLO filter delay			3		μs
	lin Operating current	FB = 3V, $V_{in} = 48\text{V}$		550	750	μA
	lin Shutdown Current	RT/SD = 0V		110	176	μA
Switch Characteristics						
	Buck switch Rds(on)	Itest = 200 mA		1.25	2.57	Ω
	Gate Drive UVLO	Vbst – Vsw Rising	2.8	3.8	4.8	V
	Gate Drive UVLO hysteresis			490		mV
	Pre-charge switch voltage	At 1 mA		0.8		V
	Pre-charge switch on-time			150		ns
Current Limit						
	Current Limit Threshold		0.41	0.51	0.61	A
	Current Limit Response Time	I _{switch} Overdrive = 0.1A, Time to Switch Off		350		ns
T _{OFF-1}	OFF time generator	FB=0V, R _{CL} = 100K		35		μs
T _{OFF-2}	OFF time generator	FB=2.3V, R _{CL} = 100K		2.56		μs
On Time Generator						
	T _{ON - 1}	$V_{in} = 10\text{V}$, Ron = 200K	2.15	2.77	3.5	μs
	T _{ON - 2}	$V_{in} = 95\text{V}$, Ron = 200K	200	300	420	ns
	Remote Shutdown Threshold	Rising	0.40	0.70	1.05	V
	Remote Shutdown Hysteresis			35		mV
Minimum Off Time						
	Minimum Off Timer	FB = 0V		300		ns
Regulation and OV Comparators						
	FB Reference Threshold	Internal reference, Trip point for switch ON	2.445	2.5	2.550	V
	FB Over-Voltage Threshold	Trip point for switch OFF		2.875		V
	FB Bias Current			100		nA
Thermal Shutdown						
Tsd	Thermal Shutdown Temperature			165		$^\circ\text{C}$
	Thermal Shutdown Hysteresis			25		$^\circ\text{C}$
Thermal Resistance						
θ_{JA}	Junction to Ambient	VSSOP Package		200		$^\circ\text{C}/\text{W}$
		WSOP Package		40		$^\circ\text{C}/\text{W}$

(1) All electrical characteristics having room temperature limits are tested during production with $T_A = T_J = 25^\circ\text{C}$. All hot and cold limits are specified by correlating the electrical characteristics to process and temperature variations and applying statistical process control.

Typical Performance Characteristics

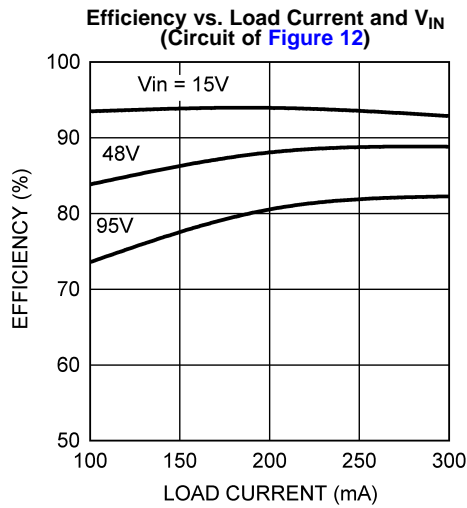

Figure 3.

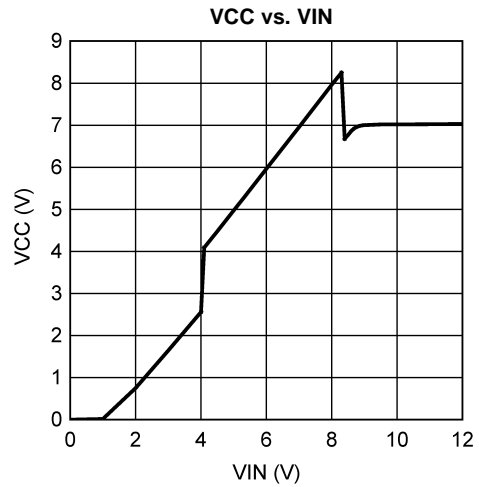

Figure 4.

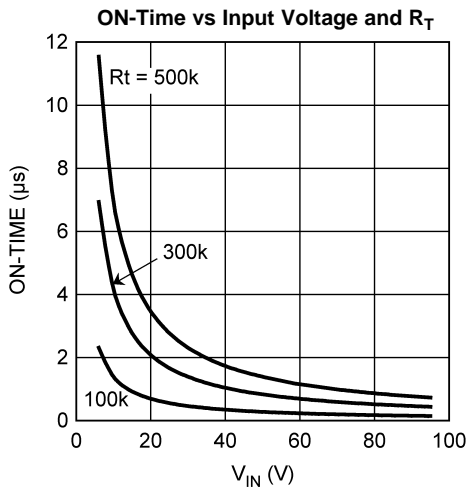

Figure 5.

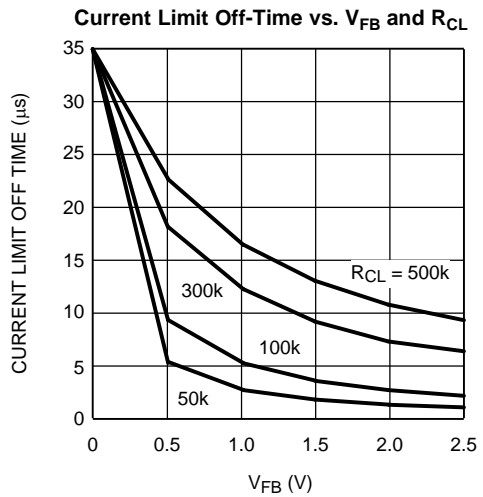

Figure 6.

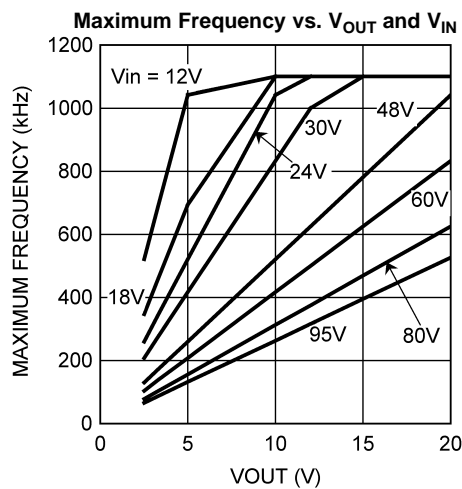

Figure 7.

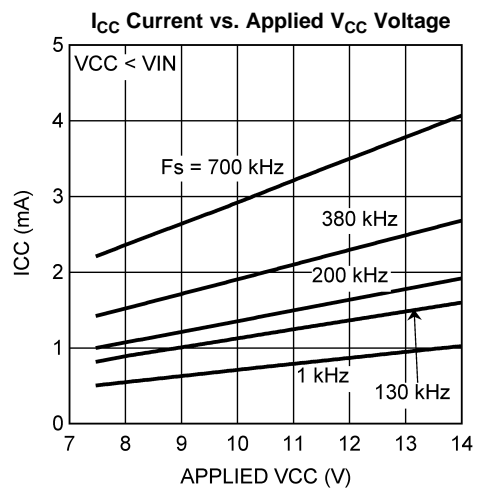
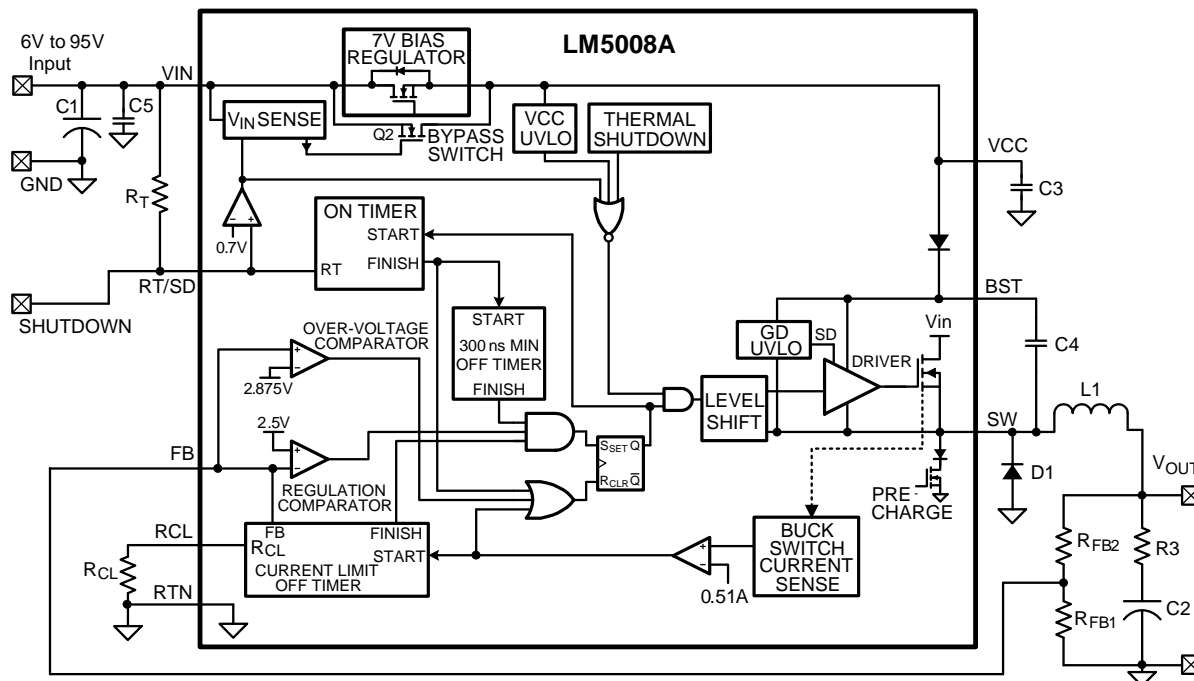

Figure 8.

BLOCK DIAGRAM



FUNCTIONAL DESCRIPTION

The LM5008A Step Down Switching Regulator features all the functions needed to implement a low cost, efficient, Buck bias power converter. This high voltage regulator contains a 100 V N-Channel Buck Switch, is easy to implement and is provided in the VSSOP-8 and the thermally enhanced WSON-8 packages. The regulator is based on a control scheme using an on-time inversely proportional to V_{IN} . The control scheme requires no loop compensation. Current limit is implemented with forced off-time, which is inversely proportional to V_{OUT} . This scheme ensures short circuit control while providing minimum foldback.

The LM5008A can be applied in numerous applications to efficiently regulate down higher voltages. This regulator is well suited for 48 Volt Telecom and the new 42V Automotive power bus ranges. Features include: Thermal Shutdown, V_{CC} under-voltage lockout, Gate drive under-voltage lockout, Max Duty Cycle limit timer, intelligent current limit off timer, and a pre-charge switch.

Control Circuit Overview

The LM5008A is a Buck DC-DC regulator that uses a control scheme in which the on-time varies inversely with line voltage (V_{IN}). Control is based on a comparator and the on-time one-shot, with the output voltage feedback (FB) compared to an internal reference (2.5V). If the FB level is below the reference the buck switch is turned on for a fixed time determined by the line voltage and a programming resistor (R_T). Following the ON period the switch will remain off for at least the minimum off-timer period of 300ns. If FB is still below the reference at that time the switch will turn on again for another on-time period. This will continue until regulation is achieved.

The LM5008A operates in discontinuous conduction mode at light load currents, and continuous conduction mode at heavy load current. In discontinuous conduction mode, current through the output inductor starts at zero and ramps up to a peak during the on-time, then ramps back to zero before the end of the off-time. The next on-time period starts when the voltage at FB falls below the internal reference - until then the inductor current remains zero. In this mode the operating frequency is lower than in continuous conduction mode, and varies with load current. Therefore at light loads the conversion efficiency is maintained, since the switching losses reduce with the reduction in load and frequency. The discontinuous operating frequency can be calculated as follows:

$$F = \frac{V_{OUT}^2 \times L \times 1.04 \times 10^{20}}{R_L \times (R_T)^2}$$

where

- R_L = the load resistance (1)

In continuous conduction mode, current flows continuously through the inductor and never ramps down to zero. In this mode the operating frequency is greater than the discontinuous mode frequency and remains relatively constant with load and line variations. The approximate continuous mode operating frequency can be calculated as follows:

$$F = \frac{V_{OUT}}{1.385 \times 10^{-10} \times R_T} \quad (2)$$

The output voltage (V_{OUT}) is programmed by two external resistors as shown in the Block Diagram. The regulation point can be calculated as follows:

$$V_{OUT} = 2.5 \times (R_{FB1} + R_{FB2}) / R_{FB1} \quad (3)$$

The LM5008A regulates the output voltage based on ripple voltage at the feedback input, requiring a minimum amount of ESR for the output capacitor C2. A minimum of 25mV to 50mV of ripple voltage at the feedback pin (FB) is required for the LM5008A. In cases where the capacitor ESR is too small, additional series resistance may be required (R3 in the Block Diagram).

For applications where lower output voltage ripple is required the output can be taken directly from a low ESR output capacitor, as shown in Figure 9. However, R3 slightly degrades the load regulation.

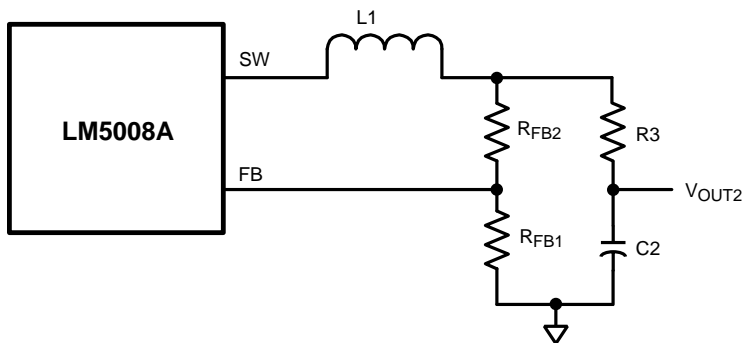

Figure 9. Low Ripple Output Configuration

Start-Up Regulator (V_{CC})

The high voltage bias regulator is integrated within the LM5008A. The input pin (V_{IN}) can be connected directly to line voltages between 6V and 95V, with transient capability to 100V. Referring to the block diagram and the graph of V_{CC} vs V_{IN} , when V_{IN} is between 6V and the bypass threshold (nominally 8.5V), the bypass switch (Q2) is on, and V_{CC} tracks V_{IN} within 100 mV to 150 mV. The bypass switch on-resistance is approximately 100Ω, with inherent current limiting at approximately 100 mA. When V_{IN} is above the bypass threshold Q2 is turned off, and V_{CC} is regulated at 7V. The V_{CC} regulator output current is limited at approximately 9.2 mA. When the LM5008A is shutdown using the RT/SD pin, the V_{CC} bypass switch is shut off regardless of the voltage at V_{IN} .

When V_{IN} exceeds the bypass threshold, the time required for Q2 to shut off is approximately 2 - 3 μs. The capacitor at VCC (C3) must be a minimum of 0.47 μF to prevent the voltage at VCC from rising above its absolute maximum rating in response to a step input applied at V_{IN} . C3 must be located as close as possible to the VCC and RTN pins. In applications with a relatively high input voltage, power dissipation in the bias regulator is a concern. An auxiliary voltage of between 7.5V and 14V can be diode connected to the VCC pin to shut off the V_{CC} regulator, thereby reducing internal power dissipation. The current required into the VCC pin is shown in the graph "I_{CC} Current vs. Applied V_{CC} Voltage". Internally a diode connects VCC to V_{IN} requiring that the auxiliary voltage be less than V_{IN} .

The turn-on sequence is shown in Figure 10. During the initial delay (t_1) VCC ramps up at a rate determined by its current limit and C3 while internal circuitry stabilizes. When VCC reaches the upper threshold of its under-voltage lock-out (UVLO, typically 5.3V) the buck switch is enabled. The inductor current increases to the current limit threshold (I_{LIM}) and during t_2 V_{OUT} increases as the output capacitor charges up. When V_{OUT} reaches the intended voltage the average inductor current decreases (t_3) to the nominal load current (I_O).

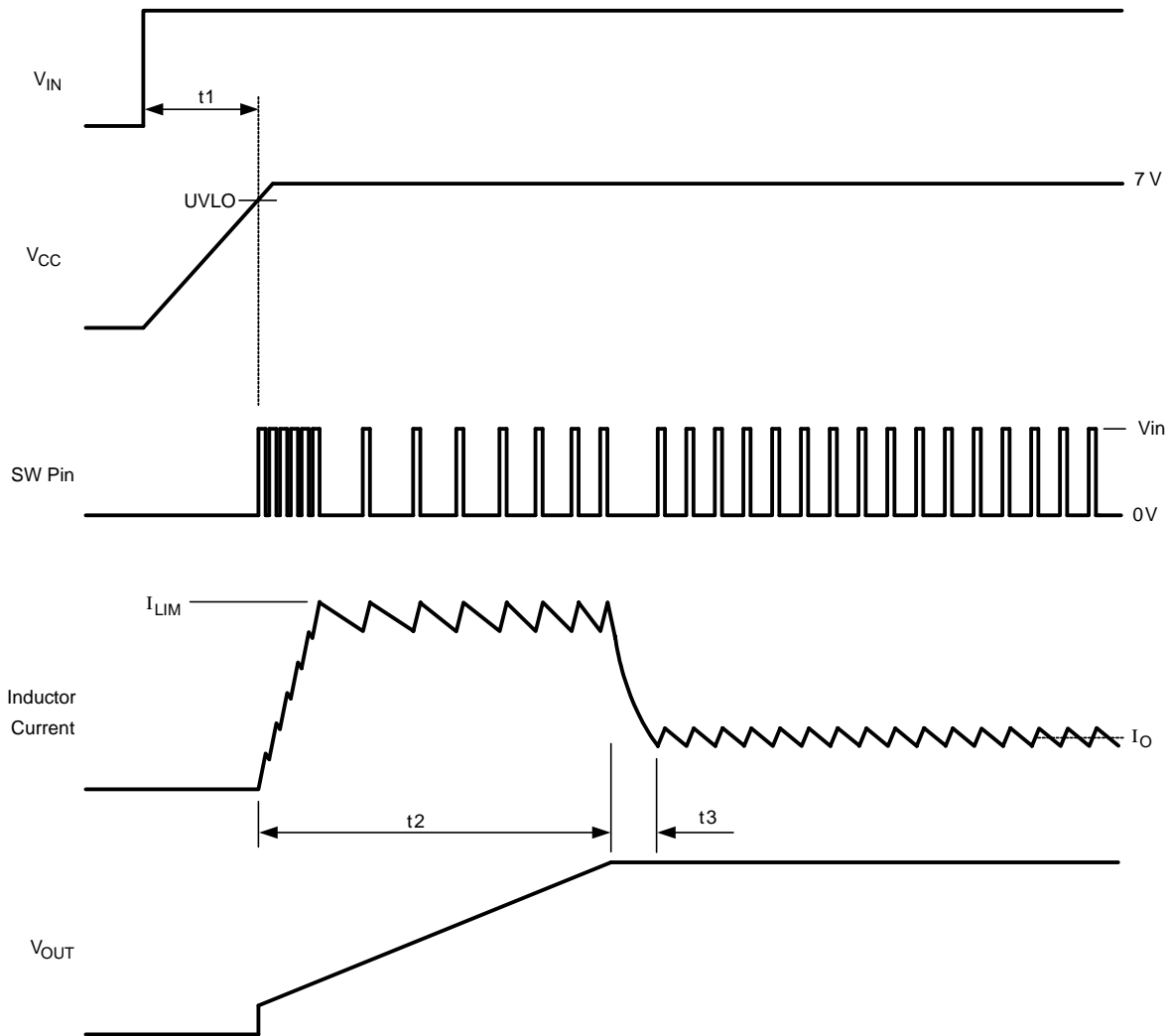

Figure 10. Startup Sequence

Regulation Comparator

The feedback voltage at FB is compared to an internal 2.5V reference. In normal operation (the output voltage is regulated), an on-time period is initiated when the voltage at FB falls below 2.5V. The buck switch will stay on for the on-time, causing the FB voltage to rise above 2.5V. After the on-time period, the buck switch will stay off until the FB voltage again falls below 2.5V. During start-up, the FB voltage will be below 2.5V at the end of each on-time, resulting in the minimum off-time of 300 ns. Bias current at the FB pin is nominally 100 nA.

Over-Voltage Comparator

The feedback voltage at FB is compared to an internal 2.875V reference. If the voltage at FB rises above 2.875V the on-time pulse is immediately terminated. This condition can occur if the input voltage, or the output load, change suddenly. The buck switch will not turn on again until the voltage at FB falls below 2.5V.

On-Time Generator and Shutdown

The on-time for the LM5008A is determined by the R_T resistor, and is inversely proportional to the input voltage (V_{IN}), resulting in a nearly constant frequency as V_{IN} is varied over its range. The on-time equation for the LM5008A is:

$$T_{ON} = 1.385 \times 10^{-10} \times R_T / V_{IN} \quad (4)$$

R_T should be selected for a minimum on-time (at maximum V_{IN}) greater than 400 ns, for proper current limit operation. This requirement limits the maximum frequency for each application, depending on V_{IN} and V_{OUT} .

The LM5008A can be remotely disabled by taking the R_T/SD pin to ground. See Figure 11. The voltage at the R_T/SD pin is between 1.5 and 3.0 volts, depending on V_{in} and the value of the R_T resistor.

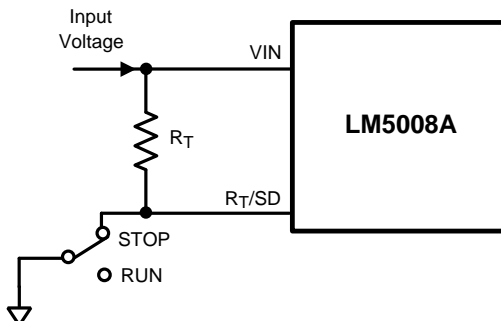

Figure 11. Shutdown Implementation

Current Limit

The LM5008A contains an intelligent current limit OFF timer. If the current in the Buck switch exceeds 0.51A the present cycle is immediately terminated, and a non-resettable OFF timer is initiated. The length of off-time is controlled by an external resistor (R_{CL}) and the FB voltage (see the graph Current Limit Off-Time vs. V_{FB} and R_{CL}). When $FB = 0V$, a maximum off-time is required, and the time is preset to 35 μ s. This condition occurs when the output is shorted, and during the initial part of start-up. This amount of time ensures safe short circuit operation up to the maximum input voltage of 95V. In cases of overload where the FB voltage is above zero volts (not a short circuit) the current limit off-time will be less than 35 μ s. Reducing the off-time during less severe overloads reduces the amount of foldback, recovery time, and the start-up time. The off-time is calculated from Equation 5.

$$T_{OFF} = \frac{10^{-5}}{0.285 + \frac{V_{FB}}{6.35 \times 10^{-6} \times R_{CL}}} \quad (5)$$

The current limit sensing circuit is blanked for the first 50-70ns of each on-time so it is not falsely tripped by the current surge which occurs at turn-on. The current surge is required by the re-circulating diode (D1) for its turn-off recovery.

N-Channel Buck Switch and Driver

The LM5008A integrates an N-Channel Buck switch and associated floating high voltage gate driver. The gate driver circuit works in conjunction with an external bootstrap capacitor and an internal high voltage diode. A 0.01 μ F ceramic capacitor (C4) connected between the BST pin and SW pin provides the voltage to the driver during the on-time.

During each off-time, the SW pin is at approximately 0V, and the bootstrap capacitor charges from V_{cc} through the internal diode. The minimum OFF timer, set to 300ns, ensures a minimum time each cycle to recharge the bootstrap capacitor.

The internal pre-charge switch at the SW pin is turned on for ≈ 150 ns during the minimum off-time period, ensuring sufficient voltage exists across the bootstrap capacitor for the on-time. This feature helps prevent operating problems which can occur during very light load conditions, involving a long off-time, during which the voltage across the bootstrap capacitor could otherwise reduce below the Gate Drive UVLO threshold. The pre-charge switch also helps prevent startup problems which can occur if the output voltage is pre-charged prior to turn-on. After current limit detection, the pre-charge switch is turned on for the entire duration of the forced off-time .

Thermal Protection

The LM5008A should be operated so the junction temperature does not exceed 125°C during normal operation. An internal Thermal Shutdown circuit is provided to shutdown the LM5008A in the event of a higher than normal junction temperature. When activated, typically at 165°C, the controller is forced into a low power reset state by disabling the buck switch. This feature prevents catastrophic failures from accidental device overheating. When the junction temperature reduces below 140°C (typical hysteresis = 25°C) normal operation is resumed.

APPLICATIONS INFORMATION

SELECTION OF EXTERNAL COMPONENTS

A guide for determining the component values will be illustrated with a design example. Refer to the Block Diagram. The following steps will configure the LM5008A for:

- Input voltage range (V_{in}): 12V to 95V
- Output voltage (V_{OUT1}): 10V
- Load current (for continuous conduction mode): 100 mA to 300 mA

R_{FB1} , R_{FB2} : $V_{OUT} = V_{FB} \times (R_{FB1} + R_{FB2}) / R_{FB1}$, and since $V_{FB} = 2.5V$, the ratio of R_{FB2} to R_{FB1} calculates as 3:1. Standard values of 3.01 k Ω and 1.00 k Ω are chosen. Other values could be used as long as the 3:1 ratio is maintained.

F_s and R_T : The recommended operating frequency range for the LM5008A is 50 kHz to 1.1 MHz. Unless the application requires a specific frequency, the choice of frequency is generally a compromise since it affects the size of L1 and C2, and the switching losses. The maximum allowed frequency, based on a minimum on-time of 400 ns, is calculated from:

$$F_{MAX} = V_{OUT} / (V_{INMAX} \times 400 \text{ ns}) \quad (6)$$

For this exercise, $F_{max} = 263 \text{ kHz}$. From Equation 2, R_T calculates to 274 k Ω . A standard value 324 k Ω resistor will be used to allow for tolerances in Equation 2, resulting in a frequency of 223 kHz.

L1: The main parameter affected by the inductor is the output current ripple amplitude. The choice of inductor value therefore depends on both the minimum and maximum load currents, keeping in mind that the maximum ripple current occurs at maximum V_{in} .

a) **Minimum load current:** To maintain continuous conduction at minimum I_o (100 mA), the ripple amplitude (I_{OR}) must be less than 200 mA p-p so the lower peak of the waveform does not reach zero. L1 is calculated using Equation 7.

$$L1 = \frac{V_{OUT} \times (V_{IN} - V_{OUT})}{I_{OR} \times F_s \times V_{IN}} \quad (7)$$

At $V_{in} = 95V$, L1(min) calculates to 200 μH . The next larger standard value (220 μH) is chosen and with this value I_{OR} calculates to 182 mA p-p at $V_{in} = 95V$, and 34 mA p-p at $V_{in} = 12V$.

b) **Maximum load current:** At a load current of 300 mA, the peak of the ripple waveform must not reach the minimum value of the LM5008A's current limit threshold (410 mA). Therefore the ripple amplitude must be less than 220 mA p-p, which is already satisfied in the above calculation. With L1 = 220 μH , at maximum V_{in} and I_o , the peak of the ripple will be 391 mA. While L1 must carry this peak current without saturating or exceeding its temperature rating, it also must be capable of carrying the maximum value of the LM5008A's current limit threshold (610 mA) without saturating, since the current limit is reached during startup.

The DC resistance of the inductor should be as low as possible. For example, if the inductor's DCR is one ohm, the power dissipated at maximum load current is 0.09W. While small, it is not insignificant compared to the load power of 3W.

C3: The capacitor on the V_{CC} output provides not only noise filtering and stability, but its primary purpose is to prevent false triggering of the V_{CC} UVLO at the buck switch on/off transitions. C3 should be no smaller than 0.47 μF .

C2, and R3: When selecting the output filter capacitor C2, the items to consider are ripple voltage due to its ESR, ripple voltage due to its capacitance, and the nature of the load.

ESR and R3: A low ESR for C2 is generally desirable so as to minimize power losses and heating within the capacitor. However, the regulator requires a minimum amount of ripple voltage at the feedback input for proper loop operation. For the LM5008A the minimum ripple required at pin 5 is 25 mV p-p, requiring a minimum ripple at V_{OUT} of 100 mV. Since the minimum ripple current (at minimum V_{in}) is 34 mA p-p, the minimum ESR required at V_{OUT} is 100 mV/34 mA = 2.94 Ω . Since quality capacitors for SMPS applications have an ESR considerably less than this, R3 is inserted as shown in the Block Diagram. R3's value, along with C2's ESR, must result in at least 25 mV p-p ripple at pin 5. Generally, R3 will be 0.5 to 3.0 Ω .

R_{CL}: When current limit is detected, the minimum off-time set by this resistor must be greater than the maximum normal off-time, which occurs at maximum input voltage. Using Equation 4, the minimum on-time is 472 ns, yielding an off-time of 4 μs (at 223 kHz). Due to the 25% tolerance on the on-time, the off-time tolerance is also 25%, yielding a maximum off-time of 5 μs. Allowing for the response time of the current limit detection circuit (350 ns) increases the maximum off-time to 5.35 μs. This is increased an additional 25% to 6.7 μs to allow for the tolerances of Equation 5. Using Equation 5, R_{CL} calculates to 325 kΩ at V_{FB} = 2.5V. A standard value 332 kΩ resistor will be used.

D1: The important parameters are reverse recovery time and forward voltage. The reverse recovery time determines how long the reverse current surge lasts each time the buck switch is turned on. The forward voltage drop is significant in the event the output is short-circuited as it is only this diode's voltage which forces the inductor current to reduce during the forced off-time. For this reason, a higher voltage is better, although that affects efficiency. A good choice is a Schottky power diode, such as the DFLS1100. D1's reverse voltage rating must be at least as great as the maximum V_{in}, and its current rating be greater than the maximum current limit threshold (610 mA).

C1: This capacitor's purpose is to supply most of the switch current during the on-time, and limit the voltage ripple at V_{in}, on the assumption that the voltage source feeding V_{in} has an output impedance greater than zero. At maximum load current, when the buck switch turns on, the current into pin 8 will suddenly increase to the lower peak of the output current waveform, ramp up to the peak value, then drop to zero at turn-off. The average input current during this on-time is the load current (300 mA). For a worst case calculation, C1 must supply this average load current during the maximum on-time. To keep the input voltage ripple to less than 2V (for this exercise), C1 calculates to:

$$C1 = \frac{I \times t_{ON}}{\Delta V} = \frac{0.3A \times 3.74 \mu s}{2.0V} = 0.56 \mu F \quad (8)$$

Quality ceramic capacitors in this value have a low ESR which adds only a few millivolts to the ripple. It is the capacitance which is dominant in this case. To allow for the capacitor's tolerance, temperature effects, and voltage effects, a 1.0 μF, 100V, X7R capacitor will be used.

C4: The recommended value is 0.01μF for C4, as this is appropriate in the majority of applications. A high quality ceramic capacitor, with low ESR is recommended as C4 supplies the surge current to charge the buck switch gate at turn-on. A low ESR also ensures a quick recharge during each off-time. At minimum V_{in}, when the on-time is at maximum, it is possible during start-up that C4 will not fully recharge during each 300 ns off-time. The circuit will not be able to complete the start-up, and achieve output regulation. This can occur when the frequency is intended to be low (e.g., R_T = 500K). In this case C4 should be increased so it can maintain sufficient voltage across the buck switch driver during each on-time.

C5: This capacitor helps avoid supply voltage transients and ringing due to long lead inductance at V_{IN}. A low ESR, 0.1μF ceramic chip capacitor is recommended, located close to the LM5008A.

FINAL CIRCUIT

The final circuit is shown in Figure 12. The circuit was tested, and the resulting performance is shown in Figure 13 and Figure 14.

PC BOARD LAYOUT

The LM5008A regulation and over-voltage comparators are very fast, and as such will respond to short duration noise pulses. Layout considerations are therefore critical for optimum performance. The components at pins 1, 2, 3, 5, and 6 should be as physically close as possible to the IC, thereby minimizing noise pickup in the PC tracks. The current loop formed by D1, L1, and C2 should be as small as possible. The ground connection from D1 to C1 should be as short and direct as possible.

If the internal dissipation of the LM5008A produces excessive junction temperatures during normal operation, good use of the PC board's ground plane can help considerably to dissipate heat. The exposed pad on the bottom of the WSON-8 package can be soldered to a ground plane on the PC board, and that plane should extend out from beneath the IC to help dissipate the heat. Additionally, the use of wide PC board traces, where possible, can also help conduct heat away from the IC. Judicious positioning of the PC board within the end product, along with use of any available air flow (forced or natural convection) can help reduce the junction temperatures.

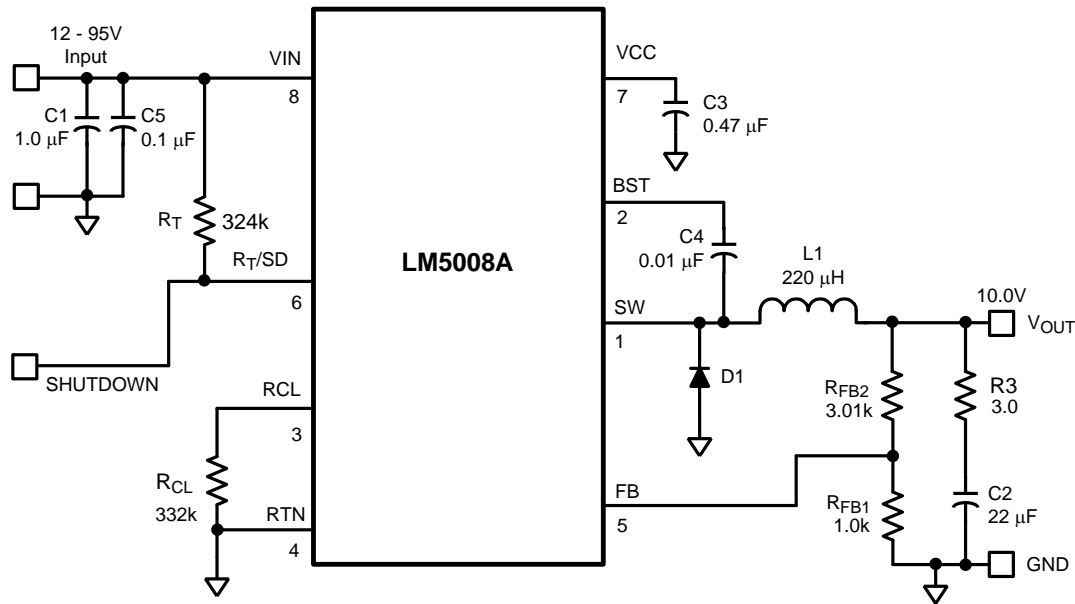
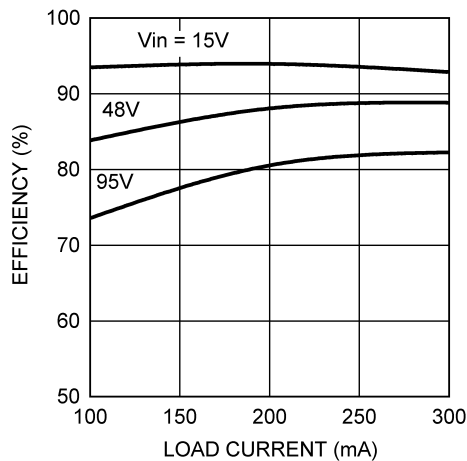
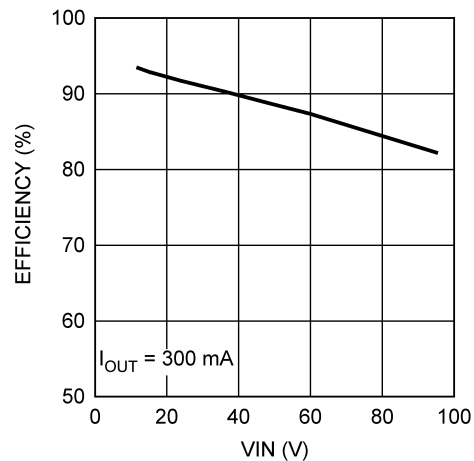

Figure 12. LM5008A Example Circuit

Table 2. Bill of Materials

Item	Description	Part Number	Value
C1	Ceramic Capacitor	TDK C4532X7R2A105M	1 μ F, 100V
C2	Ceramic Capacitor	TDK C4532X7R1E226M	22 μ F, 25V
C3	Ceramic Capacitor	Kemet C1206C474K5RAC	0.47 μ F, 50V
C4	Ceramic Capacitor	Kemet C1206C103K5RAC	0.01 μ F, 50V
C5	Ceramic Capacitor	TDK C3216X7R2A104M	0.1 μ F, 100V
D1	Schottky Power Diode	Diodes Inc. DFSL1100	100V, 1A
L1	Power Inductor	COILTRONICS DR125-221-R or TDK SLF10145T-221MR65	220 μ H
R _{FB2}	Resistor	Vishay CRCW12063011F	3.01 k Ω
R _{FB1}	Resistor	Vishay CRCW12061001F	1.0 k Ω
R3	Resistor	Vishay CRCW12063R00F	3.0 Ω
R _T	Resistor	Vishay CRCW12063243F	324 k Ω
R _{CL}	Resistor	Vishay CRCW12063323F	332 k Ω
U1	Switching Regulator	LM5008A	

Figure 13. Efficiency vs. Load Current and V_{IN} Figure 14. Efficiency vs. V_{IN}

LOW OUTPUT RIPPLE CONFIGURATIONS

For applications where low output ripple is required, the following options can be used to reduce or nearly eliminate the ripple.

a) Reduced ripple configuration: In Figure 15, C_{ff} is added across R_{FB2} to AC-couple the ripple at V_{OUT} directly to the FB pin. This allows the ripple at V_{OUT} to be reduced to a minimum of 25 mVp-p by reducing R_3 , since the ripple at V_{OUT} is not attenuated by the feedback resistors. The minimum value for C_{ff} is determined from:

$$C_{ff} = \frac{3 \times t_{ON(max)}}{(R_{FB1} // R_{FB2})}$$

where

- $t_{ON(max)}$ is the maximum on-time, which occurs at $V_{IN(min)}$. The next larger standard value capacitor should be used for C_{ff} . (9)

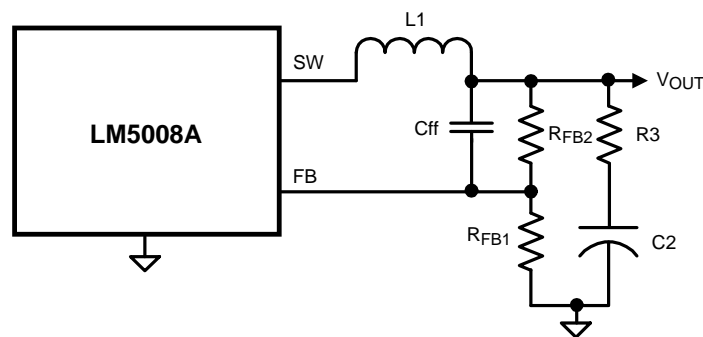

Figure 15. Reduced Ripple Configuration

b) Minimum ripple configuration: If the application requires a lower value of ripple (<10 mVp-p), the circuit of Figure 16 can be used. R_3 is removed, and the resulting output ripple voltage is determined by the inductor's ripple current and C_2 's characteristics. R_A and C_A are chosen to generate a sawtooth waveform at their junction, and that voltage is AC-coupled to the FB pin via C_B . To determine the values for R_A , C_A and C_B , use the following procedure:

$$\text{Calculate } V_A = V_{OUT} - (V_{SW} \times (1 - (V_{OUT}/V_{IN(min)})))$$

where

- V_{SW} is the absolute value of the voltage at the SW pin during the off-time (typically 1V). V_A is the DC voltage at the R_A/C_A junction, and is used in Equation 11. (10)

$$\text{Calculate } R_A \times C_A = (V_{IN(min)} - V_A) \times t_{ON}/\Delta V$$

where

- t_{ON} is the maximum on-time (at minimum input voltage), and ΔV is the desired ripple amplitude at the RA/CA junction (typically 40-50 mV). RA and CA are then chosen from standard value components to satisfy the above product. Typically CA is 1000 pF to 5000 pF, and RA is 10 k Ω to 300 k Ω . CB is then chosen large compared to CA, typically 0.1 μ F. (11)

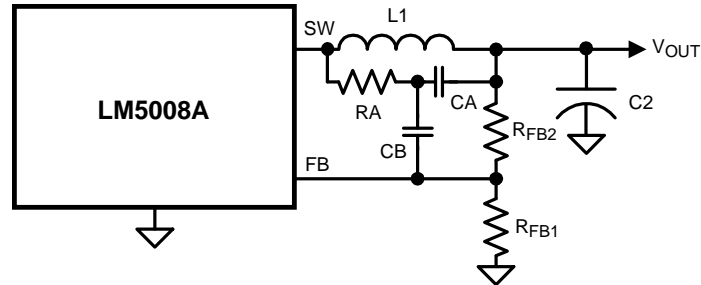

Figure 16. Minimum Output Ripple Using Ripple Injection

c) **Alternate minimum ripple configuration:** The circuit in Figure 17 is the same as that in the Block Diagram, except the output voltage is taken from the junction of R3 and C2. The ripple at V_{OUT} is determined by the inductor's ripple current and C2's characteristics. However, R3 slightly degrades the load regulation. This circuit may be suitable if the load current is fairly constant.

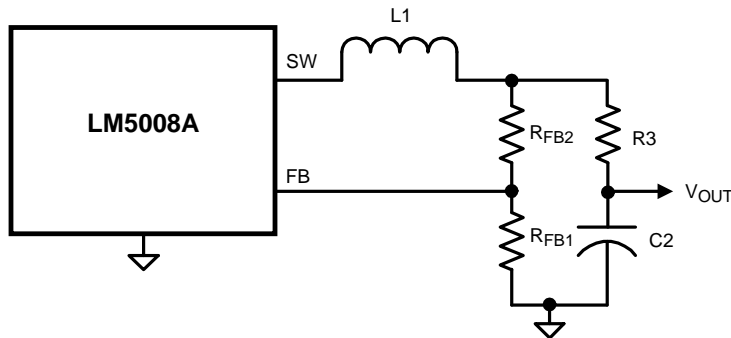

Figure 17. Alternate Minimum Output Ripple

REVISION HISTORY

Changes from Revision E (March 2013) to Revision F	Page
• Changed layout of National Data Sheet to TI format	15

PACKAGING INFORMATION

Orderable Device	Status (1)	Package Type	Package Drawing	Pins	Package Qty	Eco Plan (2)	Lead/Ball Finish	MSL Peak Temp (3)	Op Temp (°C)	Top-Side Markings (4)	Samples
LM5008AMM/NOPB	ACTIVE	VSSOP	DGK	8	1000	Green (RoHS & no Sb/Br)	CU SN	Level-1-260C-UNLIM	-40 to 125	SAYA	Samples
LM5008AMMX/NOPB	ACTIVE	VSSOP	DGK	8	3500	Green (RoHS & no Sb/Br)	CU SN	Level-1-260C-UNLIM	-40 to 125	SAYA	Samples
LM5008ASD/NOPB	ACTIVE	WSOP	NGU	8	1000	Green (RoHS & no Sb/Br)	CU SN	Level-1-260C-UNLIM	-40 to 125	L00070A	Samples
LM5008ASDX/NOPB	ACTIVE	WSOP	NGU	8	4500	Green (RoHS & no Sb/Br)	CU SN	Level-1-260C-UNLIM	-40 to 125	L00070A	Samples

(1) The marketing status values are defined as follows:

ACTIVE: Product device recommended for new designs.

LIFEBUY: TI has announced that the device will be discontinued, and a lifetime-buy period is in effect.

NRND: Not recommended for new designs. Device is in production to support existing customers, but TI does not recommend using this part in a new design.

PREVIEW: Device has been announced but is not in production. Samples may or may not be available.

OBSELETE: TI has discontinued the production of the device.

(2) Eco Plan - The planned eco-friendly classification: Pb-Free (RoHS), Pb-Free (RoHS Exempt), or Green (RoHS & no Sb/Br) - please check <http://www.ti.com/productcontent> for the latest availability information and additional product content details.

TBD: The Pb-Free/Green conversion plan has not been defined.

Pb-Free (RoHS): TI's terms "Lead-Free" or "Pb-Free" mean semiconductor products that are compatible with the current RoHS requirements for all 6 substances, including the requirement that lead not exceed 0.1% by weight in homogeneous materials. Where designed to be soldered at high temperatures, TI Pb-Free products are suitable for use in specified lead-free processes.

Pb-Free (RoHS Exempt): This component has a RoHS exemption for either 1) lead-based flip-chip solder bumps used between the die and package, or 2) lead-based die adhesive used between the die and leadframe. The component is otherwise considered Pb-Free (RoHS compatible) as defined above.

Green (RoHS & no Sb/Br): TI defines "Green" to mean Pb-Free (RoHS compatible), and free of Bromine (Br) and Antimony (Sb) based flame retardants (Br or Sb do not exceed 0.1% by weight in homogeneous material)

(3) MSL, Peak Temp. -- The Moisture Sensitivity Level rating according to the JEDEC industry standard classifications, and peak solder temperature.

(4) Multiple Top-Side Markings will be inside parentheses. Only one Top-Side Marking contained in parentheses and separated by a "~" will appear on a device. If a line is indented then it is a continuation of the previous line and the two combined represent the entire Top-Side Marking for that device.

Important Information and Disclaimer: The information provided on this page represents TI's knowledge and belief as of the date that it is provided. TI bases its knowledge and belief on information provided by third parties, and makes no representation or warranty as to the accuracy of such information. Efforts are underway to better integrate information from third parties. TI has taken and continues to take reasonable steps to provide representative and accurate information but may not have conducted destructive testing or chemical analysis on incoming materials and chemicals. TI and TI suppliers consider certain information to be proprietary, and thus CAS numbers and other limited information may not be available for release.

In no event shall TI's liability arising out of such information exceed the total purchase price of the TI part(s) at issue in this document sold by TI to Customer on an annual basis.

TAPE AND REEL INFORMATION

QUADRANT ASSIGNMENTS FOR PIN 1 ORIENTATION IN TAPE

*All dimensions are nominal

Device	Package Type	Package Drawing	Pins	SPQ	Reel Diameter (mm)	Reel Width W1 (mm)	A0 (mm)	B0 (mm)	K0 (mm)	P1 (mm)	W (mm)	Pin1 Quadrant
LM5008AMMX/NOPB	VSSOP	DGK	8	3500	330.0	12.4	5.3	3.4	1.4	8.0	12.0	Q1
LM5008ASD/NOPB	WSOP	NGU	8	1000	178.0	12.4	4.3	4.3	1.3	8.0	12.0	Q1
LM5008ASDX/NOPB	WSOP	NGU	8	4500	330.0	12.4	4.3	4.3	1.3	8.0	12.0	Q1

TAPE AND REEL BOX DIMENSIONS



*All dimensions are nominal

Device	Package Type	Package Drawing	Pins	SPQ	Length (mm)	Width (mm)	Height (mm)
LM5008AMMX/NOPB	VSSOP	DGK	8	3500	367.0	367.0	35.0
LM5008ASD/NOPB	WSON	NGU	8	1000	210.0	185.0	35.0
LM5008ASDX/NOPB	WSON	NGU	8	4500	367.0	367.0	35.0

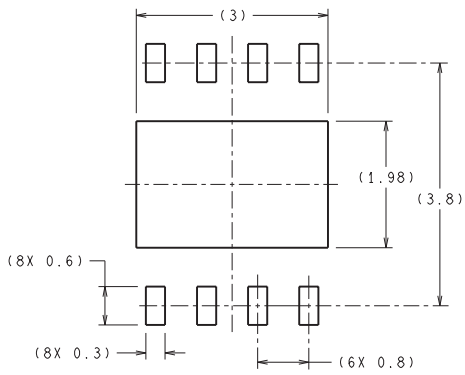

- NOTES:
- A. All linear dimensions are in millimeters.
 - B. This drawing is subject to change without notice.
 - C. Publication IPC-7351 is recommended for alternate designs.
 - D. Laser cutting apertures with trapezoidal walls and also rounding corners will offer better paste release. Customers should contact their board assembly site for stencil design recommendations. Refer to IPC-7525 for other stencil recommendations.
 - E. Customers should contact their board fabrication site for solder mask tolerances between and around signal pads.

NGU0008B



RECOMMENDED LAND PATTERN

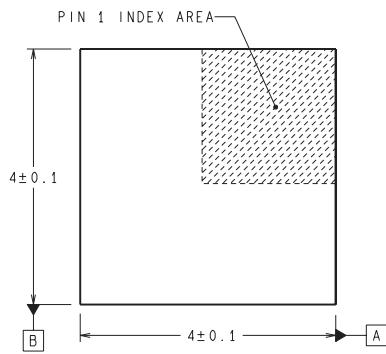

DIMENSIONS ARE IN MILLIMETERS
DIMENSIONS IN () FOR REFERENCE ONLY

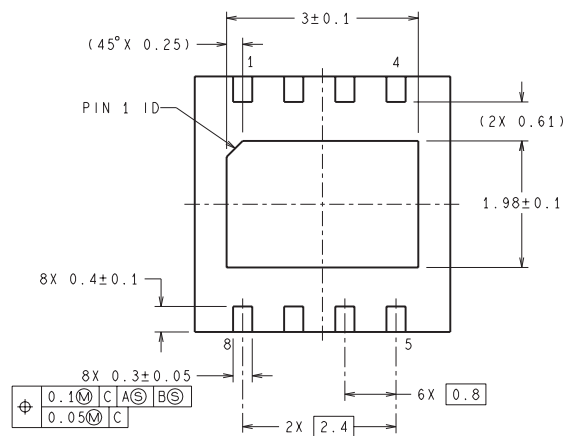
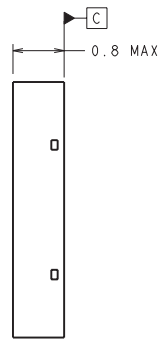

⊕	0.1	M	C	A	⊙	B	⊙
	0.05	M	C				

SDC08B (Rev A)

IMPORTANT NOTICE

Texas Instruments Incorporated and its subsidiaries (TI) reserve the right to make corrections, enhancements, improvements and other changes to its semiconductor products and services per JESD46, latest issue, and to discontinue any product or service per JESD48, latest issue. Buyers should obtain the latest relevant information before placing orders and should verify that such information is current and complete. All semiconductor products (also referred to herein as "components") are sold subject to TI's terms and conditions of sale supplied at the time of order acknowledgment.

TI warrants performance of its components to the specifications applicable at the time of sale, in accordance with the warranty in TI's terms and conditions of sale of semiconductor products. Testing and other quality control techniques are used to the extent TI deems necessary to support this warranty. Except where mandated by applicable law, testing of all parameters of each component is not necessarily performed.

TI assumes no liability for applications assistance or the design of Buyers' products. Buyers are responsible for their products and applications using TI components. To minimize the risks associated with Buyers' products and applications, Buyers should provide adequate design and operating safeguards.

TI does not warrant or represent that any license, either express or implied, is granted under any patent right, copyright, mask work right, or other intellectual property right relating to any combination, machine, or process in which TI components or services are used. Information published by TI regarding third-party products or services does not constitute a license to use such products or services or a warranty or endorsement thereof. Use of such information may require a license from a third party under the patents or other intellectual property of the third party, or a license from TI under the patents or other intellectual property of TI.

Reproduction of significant portions of TI information in TI data books or data sheets is permissible only if reproduction is without alteration and is accompanied by all associated warranties, conditions, limitations, and notices. TI is not responsible or liable for such altered documentation. Information of third parties may be subject to additional restrictions.

Resale of TI components or services with statements different from or beyond the parameters stated by TI for that component or service voids all express and any implied warranties for the associated TI component or service and is an unfair and deceptive business practice. TI is not responsible or liable for any such statements.

Buyer acknowledges and agrees that it is solely responsible for compliance with all legal, regulatory and safety-related requirements concerning its products, and any use of TI components in its applications, notwithstanding any applications-related information or support that may be provided by TI. Buyer represents and agrees that it has all the necessary expertise to create and implement safeguards which anticipate dangerous consequences of failures, monitor failures and their consequences, lessen the likelihood of failures that might cause harm and take appropriate remedial actions. Buyer will fully indemnify TI and its representatives against any damages arising out of the use of any TI components in safety-critical applications.

In some cases, TI components may be promoted specifically to facilitate safety-related applications. With such components, TI's goal is to help enable customers to design and create their own end-product solutions that meet applicable functional safety standards and requirements. Nonetheless, such components are subject to these terms.

No TI components are authorized for use in FDA Class III (or similar life-critical medical equipment) unless authorized officers of the parties have executed a special agreement specifically governing such use.

Only those TI components which TI has specifically designated as military grade or "enhanced plastic" are designed and intended for use in military/aerospace applications or environments. Buyer acknowledges and agrees that any military or aerospace use of TI components which have **not** been so designated is solely at the Buyer's risk, and that Buyer is solely responsible for compliance with all legal and regulatory requirements in connection with such use.

TI has specifically designated certain components as meeting ISO/TS16949 requirements, mainly for automotive use. In any case of use of non-designated products, TI will not be responsible for any failure to meet ISO/TS16949.

Products

Audio	www.ti.com/audio
Amplifiers	amplifier.ti.com
Data Converters	dataconverter.ti.com
DLP® Products	www.dlp.com
DSP	dsp.ti.com
Clocks and Timers	www.ti.com/clocks
Interface	interface.ti.com
Logic	logic.ti.com
Power Mgmt	power.ti.com
Microcontrollers	microcontroller.ti.com
RFID	www.ti-rfid.com
OMAP Applications Processors	www.ti.com/omap
Wireless Connectivity	www.ti.com/wirelessconnectivity

Applications

Automotive and Transportation	www.ti.com/automotive
Communications and Telecom	www.ti.com/communications
Computers and Peripherals	www.ti.com/computers
Consumer Electronics	www.ti.com/consumer-apps
Energy and Lighting	www.ti.com/energy
Industrial	www.ti.com/industrial
Medical	www.ti.com/medical
Security	www.ti.com/security
Space, Avionics and Defense	www.ti.com/space-avionics-defense
Video and Imaging	www.ti.com/video

TI E2E Community

e2e.ti.com

AMEYA360

Components Supply Platform

Authorized Distribution Brand :



Website :

Welcome to visit www.ameya360.com

Contact Us :

➤ Address :

401 Building No.5, JiuGe Business Center, Lane 2301, Yishan Rd
Minhang District, Shanghai , China

➤ Sales :

Direct +86 (21) 6401-6692

Email amall@ameya360.com

QQ 800077892

Skype [ameyasales1](#) [ameyasales2](#)

➤ Customer Service :

Email service@ameya360.com

➤ Partnership :

Tel +86 (21) 64016692-8333

Email mkt@ameya360.com