

**ON Semiconductor®**<http://onsemi.com>

LE25U20AMB

CMOS IC

2M-bit (256K×8) Serial Flash Memory

Overview

The LE25U20AMB is a serial interface-compatible flash memory device with a 256K × 8-bit configuration. It uses a single 2.5V power supply. While making the most of the features inherent to a serial flash memory device, the LE25U20AMB is housed in an 8-pin ultra-miniature package. These features make this device ideally suited to storing program codes in applications such as portable information devices, which are required to have increasingly more compact dimensions. Moreover, by using the small sector erase function this product is also suitable for the parameter or the date storage usage with comparatively little rewriting times that becomes a capacity shortage in EEPROM.

Features

- Read / write operations enabled by single 2.5V power supply: 2.30 to 3.60V supply voltage range
- Operating frequency : 30MHz
- Temperature range : -40 to 85°C
- Serial interface : SPI mode 0, mode 3 supported
- Sector size : 4K bytes/small sector, 64K bytes/sector
- Small sector erase, sector erase, chip erase functions
- Page program function (256 bytes / page)
- Block protect function
- Status functions : Ready/busy information, protect information
- Highly reliable read/write
 - Number of rewrite times: 100,000 times
 - Small sector erase time : 40ms (typ.), 150ms (max.)
 - Sector erase time : 80ms (typ.), 250ms (max.)
 - Chip erase time : 250ms (typ.), 1.6s (max.)
 - Page program time : 4.0ms/256 bytes (typ.), 5.0ms/256 bytes (max.)
- Data retention period : 20 years
- Package : SOP8K (200mil)

* This product is licensed from Silicon Storage Technology, Inc. (USA).

Package Dimensions

unit : mm (typ)

3398

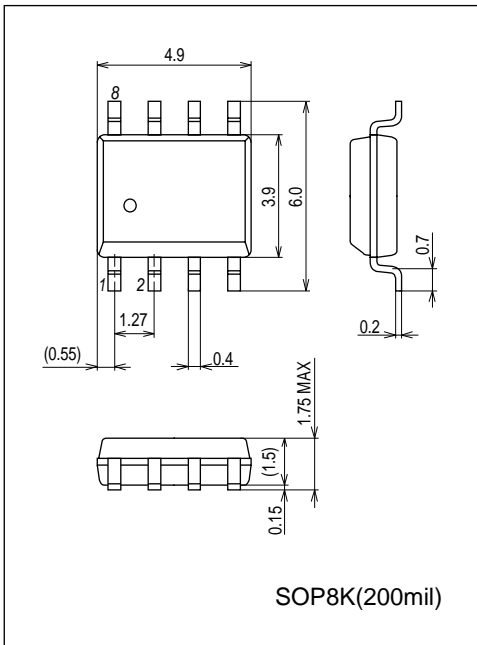
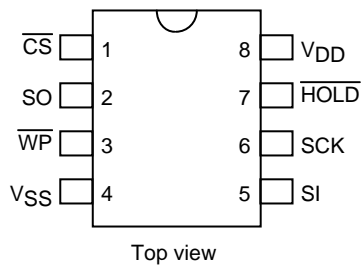

Figure 1 Pin Assignments



LE25U20AMB

Figure 2 Block Diagram

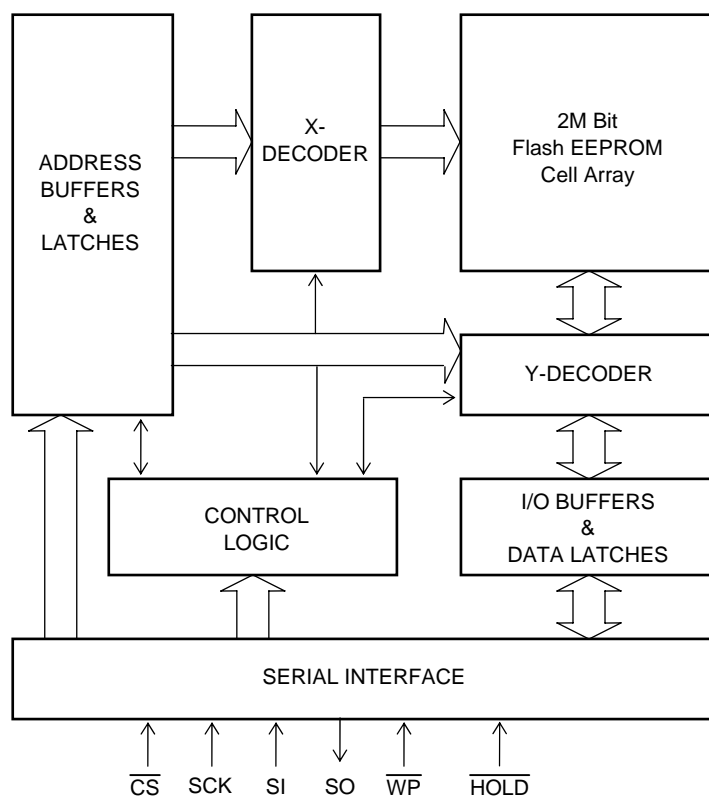

Table 1 Pin Description

Symbol	Pin Name	Description
SCK	Serial clock	This pin controls the data input/output timing. The input data and addresses are latched synchronized to the rising edge of the serial clock, and the data is output synchronized to the falling edge of the serial clock.
SI	Serial data input	The data and addresses are input from this pin, and latched internally synchronized to the rising edge of the serial clock.
SO	Serial data output	The data stored inside the device is output from this pin synchronized to the falling edge of the serial clock.
$\overline{\text{CS}}$	Chip select	The device becomes active when the logic level of this pin is low; it is deselected and placed in standby status when the logic level of the pin is high.
$\overline{\text{WP}}$	Write protect	The status register write protect (SRWP) takes effect when the logic level of this pin is low.
$\overline{\text{HOLD}}$	Hold	Serial communication is suspended when the logic level of this pin is low.
V _{DD}	Power supply	This pin supplies the 2.30 to 3.60V supply voltage.
V _{SS}	Ground	This pin supplies the 0V supply voltage.

LE25U20AMB

Device Operation

The LE25U20AMB features electrical on-chip erase functions using a single 2.5V power supply, that have been added to the EPROM functions of the industry standard that support serial interfaces. Interfacing and control are facilitated by incorporating the command registers inside the chip. The read, erase, program and other required functions of the device are executed through the command registers. The command addresses and data input in accordance with "Table 2 Command Settings" are latched inside the device in order to execute the required operations. "Figure 3 Serial Input Timing" shows the timing waveforms of the serial data input. First, at the falling \overline{CS} edge the device is selected, and serial input is enabled for the commands, addresses, etc. These inputs are introduced internally in sequence starting with bit 7 in synchronization with the rising SCK edge. At this time, output pin SO is in the high-impedance state. The output pin is placed in the low-impedance state when the data is output in sequence starting with bit 7 synchronized to the falling clock edge during read, status register read and silicon ID. Refer to "Figure 4 Serial Output Timing" for the serial output timing.

The LE25U20AMB supports both serial interface SPI mode 0 and SPI mode 3. At the falling \overline{CS} edge, SPI mode 0 is automatically selected if the logic level of SCK is low, and SPI mode 3 is automatically selected if the logic level of SCK is high.

Table 2 Command Settings

Command	1st bus cycle	2nd bus cycle	3rd bus cycle	4th bus cycle	5th bus cycle	6th bus cycle	Nth bus cycle
Read	03h	A23-A16	A15-A8	A7-A0			
	0Bh	A23-A16	A15-A8	A7-A0	X		
Small sector erase	D7h/20h	A23-A16	A15-A8	A7-A0			
Sector erase	D8h	A23-A16	A15-A8	A7-A0			
Chip erase	C7h						
Page program	02h	A23-A16	A15-A8	A7-A0	PD *	PD *	PD *
Write enable	06h						
Write disable	04h						
Power down	B9h						
Status register read	05h						
Status register write	01h	DATA					
Read silicon ID 1	9Fh						
Read silicon ID 2	ABh	X	X	X			
Exit power down mode	ABh						

Explanatory notes for Table 2

"X" signifies "don't care" (that is to say, any value may be input).

The "h" following each code indicates that the number given is in hexadecimal notation.

Addresses A23 to A18 for all commands are "Don't care".

In order for commands other than the read command to be recognized, \overline{CS} must rise after all the bus cycle input.

*: "PD" stands for page program data.

Figure 3 Serial Input Timing

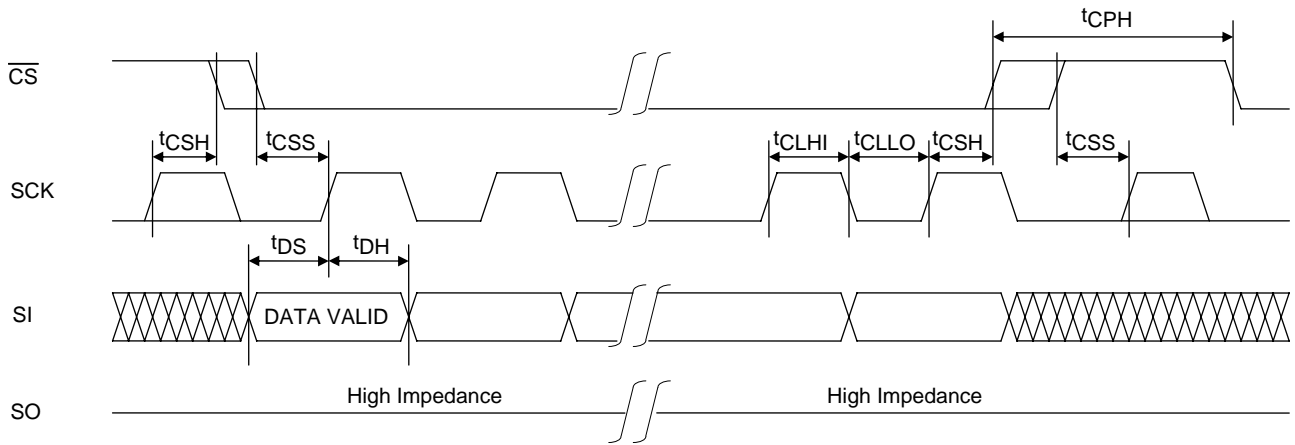
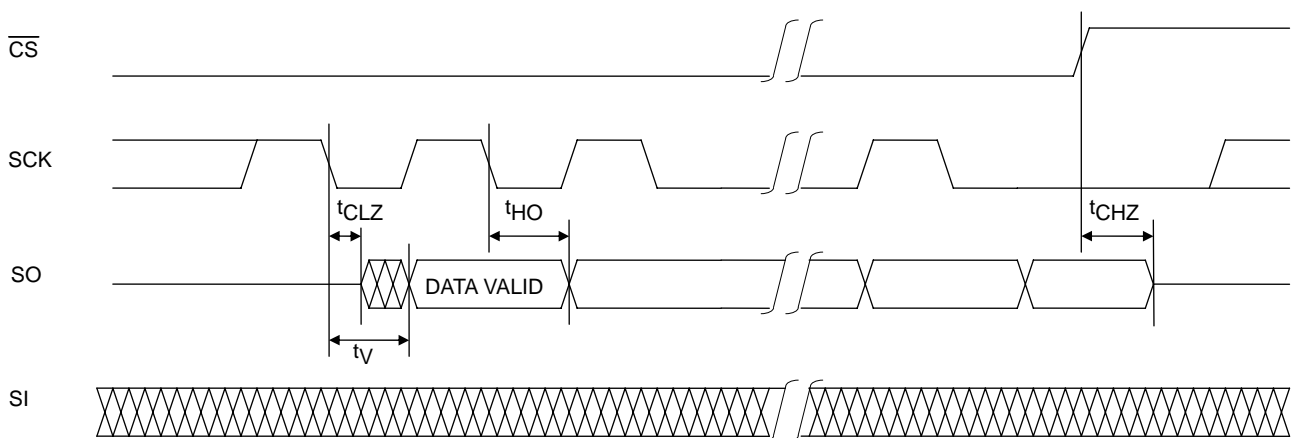

Figure 4 Serial Output Timing



Description of Commands and Their Operations

"Table 2 Command Settings" provides a list and overview of the commands. A detailed description of the functions and operations corresponding to each command is presented below.

1. Read

There are two read commands, the 4 bus cycle read command and 5 bus cycle read command. Consisting of the first through fourth bus cycles, the 4 bus cycle read command inputs the 24-bit addresses following (03h), and the data in the designated addresses is output synchronized to SCK. The data is output from SO on the falling clock edge of fourth bus cycle bit 0 as a reference. "Figure 5-a 4 Bus Read" shows the timing waveforms.

Consisting of the first through fifth bus cycles, the 5 bus cycle read command inputs the 24-bit addresses and 8 dummy bits following (0Bh). The data is output from SO using the falling clock edge of fifth bus cycle bit 0 as a reference. "Figure 5-b 5 Bus Read" shows the timing waveforms. The only difference between these two commands is whether the dummy bits in the fifth bus cycle are input.

When SCK is input continuously after the read command has been input and the data in the designated addresses has been output, the address is automatically incremented inside the device while SCK is being input, and the corresponding data is output in sequence. If the SCK input is continued after the internal address arrives at the highest address (3FFFFh), the internal address returns to the lowest address (00000h), and data output is continued. By setting the logic level of CS to high, the device is deselected, and the read cycle ends. While the device is deselected, the output pin SO is in a high-impedance state.

Figure 5-a 4 Bus Read

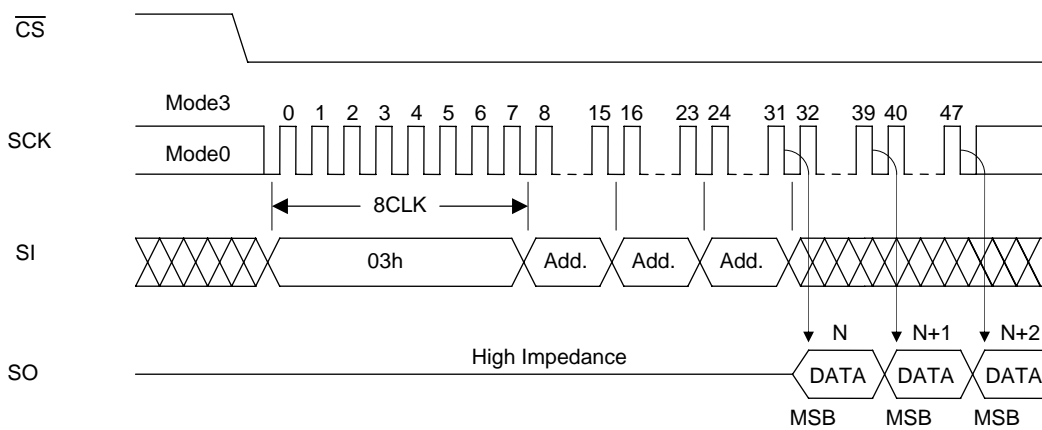
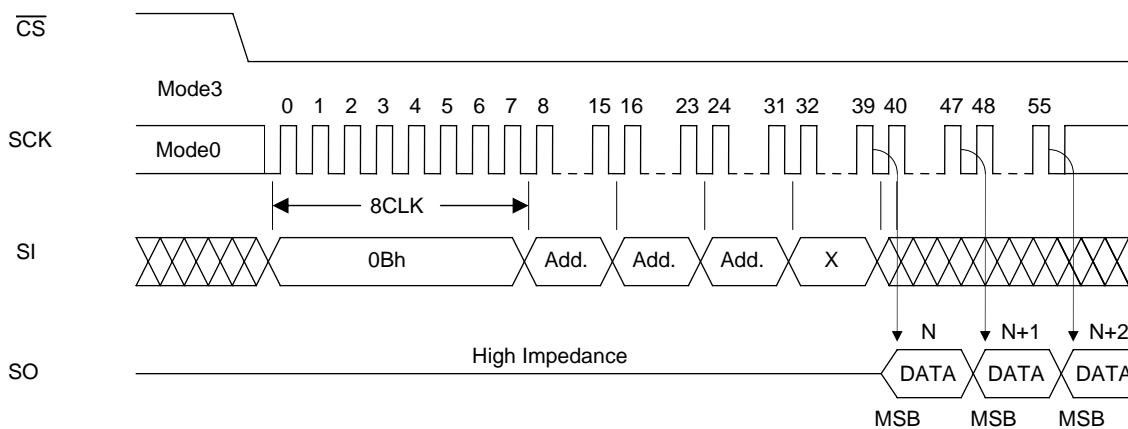

Figure 5-b 5 Bus Read



2. Status Registers

The status registers hold the operating and setting statuses inside the device, and this information can be read (status register read) and the protect information can be rewritten (status register write). There are 8 bits in total, and "Table 3 Status registers" gives the significance of each bit.

Table 3 Status Registers

Bit	Name	Logic	Function	Power-on Time Information
Bit0	$\overline{\text{RDY}}$	0	Ready	0
		1	Erase/Program	
Bit1	WEN	0	Write disabled	0
		1	Write enabled	
Bit2	BP0	0	Block protect information See status register descriptions on BP0 and BP1.	Nonvolatile information
		1		
Bit3	BP1	0		Nonvolatile information
		1		
Bit4			Reserved bits	0
Bit5				0
Bit6				0
Bit7	SRWP	0	Status register write enabled	Nonvolatile information
		1	Status register write disabled	

2-1. Status Register Read

The contents of the status registers can be read using the status register read command. This command can be executed even during the following operations.

- Small sector erase, sector erase, chip erase
- Page program
- Status register write

"Figure 6 Status Register Read" shows the timing waveforms of status register read. Consisting only of the first bus cycle, the status register command outputs the contents of the status registers synchronized to the falling edge of the clock (SCK) with which the eighth bit of (05h) has been input. In terms of the output sequence, SRWP (bit 7) is the first to be output, and each time one clock is input, all the other bits up to RDY (bit 0) are output in sequence, synchronized to the falling clock edge. If the clock input is continued after RDY (bit 0) has been output, the data is output by returning to the bit (SRWP) that was first output, after which the output is repeated for as long as the clock input is continued. The data can be read by the status register read command at any time (even during a program or erase cycle).

Figure 6 Status Register Read

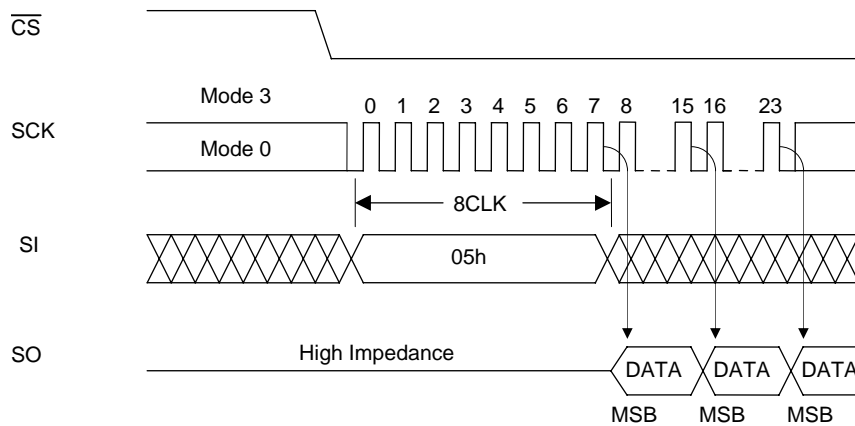

2-2. Status Register Write

The information in status registers BP0, BP1, and SRWP can be rewritten using the status register write command. RDY, WEN, bit 4, bit 5, and bit 6 are read-only bits and cannot be rewritten. The information in bits BP0, BP1, and SRWP is stored in the non-volatile memory, and when it is written in these bits, the contents are retained even at power-down. "Figure 7 Status Register Write" shows the timing waveforms of status register write, and Figure 20 shows a status register write flowchart. Consisting of the first and second bus cycles, the status register write command initiates the internal write operation at the rising CS edge after the data has been input following (01h). Erase and program are performed automatically inside the device by status register write so that erasing or other processing is unnecessary before executing the command. By the operation of this command, the information in bits BP0, BP1, and SRWP can be rewritten. Since bits RDY (bit 0), WEN (bit 1), bit 4, bit 5, and bit 6 of the status register cannot be written, no problem will arise if an attempt is made to set them to any value when rewriting the status register. Status register write ends can be detected by RDY of status register read. Information in the status registers can be rewritten 1,000 times (min.). To initiate status register write, the logic level of the WP pin must be set high and status register WEN must be set to "1".

Figure 7 Status Register Write

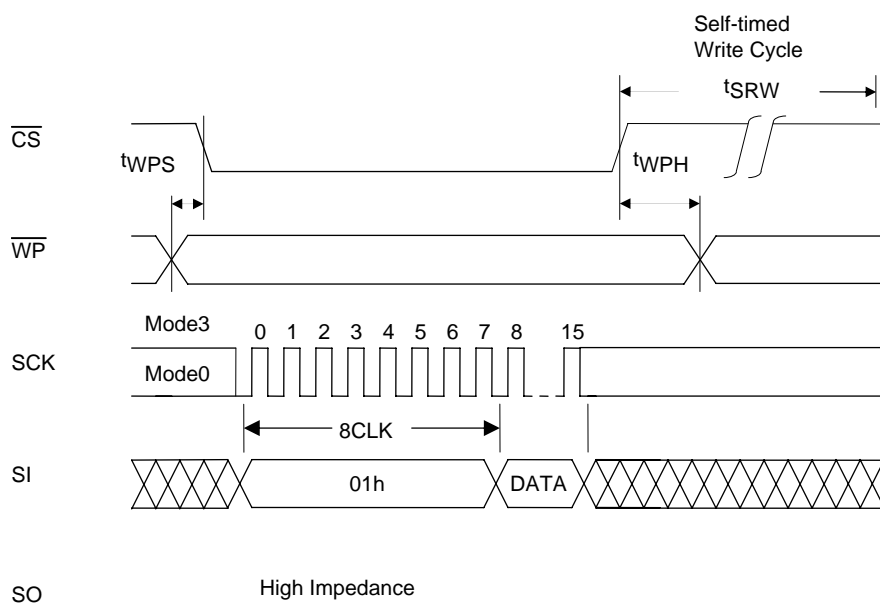

2-3. Contents of Each Status Register

RDY (bit 0)

The RDY register is for detecting the write (program, erase and status register write) end. When it is "1", the device is in a busy state, and when it is "0", it means that write is completed.

LE25U20AMB

WEN (bit 1)

The WEN register is for detecting whether the device can perform write operations. If it is set to "0", the device will not perform the write operation even if the write command is input. If it is set to "1", the device can perform write operations in any area that is not block-protected.

WEN can be controlled using the write enable and write disable commands. By inputting the write enable command (06h), WEN can be set to "1"; by inputting the write disable command (04h), it can be set to "0". In the following states, WEN is automatically set to "0" in order to protect against unintentional writing.

- At power-on
- Upon completion of small sector erase, sector erase or chip erase
- Upon completion of page program
- Upon completion of status register write

* If a write operation has not been performed inside the LE25U20AMB because, for instance, the command input for any of the write operations (small sector erase, sector erase, chip erase, page program, or status register write) has failed or a write operation has been performed for a protected address, WEN will retain the status established prior to the issue of the command concerned. Furthermore, its state will not be changed by a read operation.

BP0, BP1 (bits 2, 3)

Block protect BP0 and BP1 are status register bits that can be rewritten, and the memory space to be protected can be set depending on these bits. For the setting conditions, refer to "Table 4 Protect level setting conditions".

Table 4 Protect Level Setting Conditions

Protect Level	Status Register Bits		Protected Area
	BP1	BP0	
0 (Whole area unprotected)	0	0	None
1 (1/4 protected)	0	1	30000h to 3FFFFh
2 (1/2 protected)	1	0	20000h to 3FFFFh
3 (Whole area protected)	1	1	00000h to 3FFFFh

* Chip erase is enabled only when the protect level is 0.

SRWP (bit 7)

Status register write protect SRWP is the bit for protecting the status registers, and its information can be rewritten. When SRWP is "1" and the logic level of the WP pin is low, the status register write command is ignored, and status registers BP0, BP1, and SRWP are protected. When the logic level of the WP pin is high, the status registers are not protected regardless of the SRWP state. The SRWP setting conditions are shown in "Table 5 SRWP setting conditions".

Table 5 SRWP Setting Conditions

WP Pin	SRWP	Status Register Protect State
0	0	Unprotected
	1	Protected
1	0	Unprotected
	1	Unprotected

Bits 4, Bits 5, and Bits 6 are reserved bits, and have no significance.

3. Write Enable

Before performing any of the operations listed below, the device must be placed in the write enable state. Operation is the same as for setting status register WEN to "1", and the state is enabled by inputting the write enable command. "Figure 8 Write Enable" shows the timing waveforms when the write enable operation is performed. The write enable command consists only of the first bus cycle, and it is initiated by inputting (06h).

- Small sector erase, sector erase, chip erase
- Page program
- Status register write

4. Write Disable

The write disable command sets status register WEN to "0" to prohibit unintentional writing. "Figure 9 Write Disable" shows the timing waveforms. The write disable command consists only of the first bus cycle, and it is initiated by inputting (04h). The write disable state (WEN "0") is exited by setting WEN to "1" using the write enable command (06h).

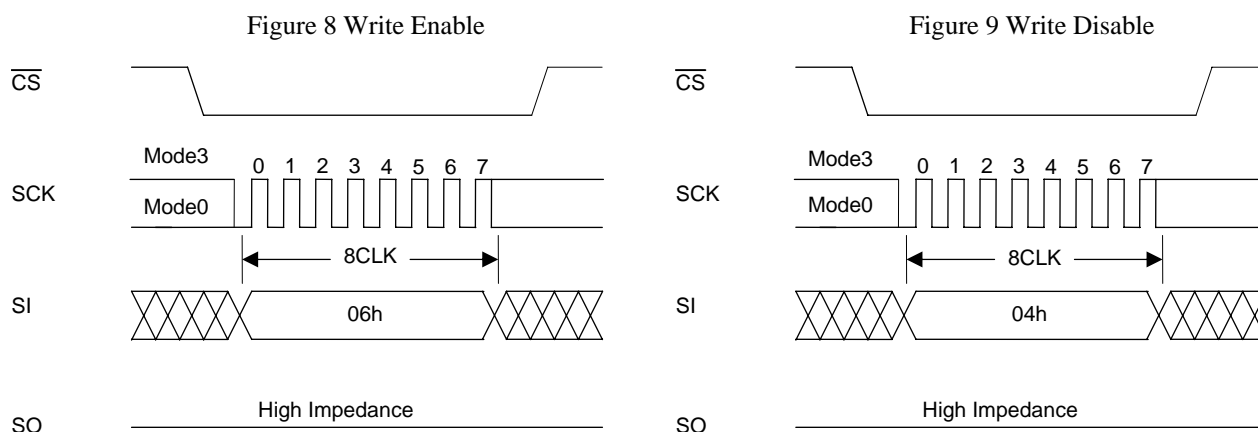

5. Power-down

The power-down command sets all the commands, with the exception of the silicon ID read command and the command to exit from power-down, to the acceptance prohibited state (power-down). "Figure 10 Power-down" shows the timing waveforms. The power-down command consists only of the first bus cycle, and it is initiated by inputting (B9h). However, a power-down command issued during an internal write operation will be ignored. The power-down state is exited using the power-down exit command (power-down is exited also when one bus cycle or more of the silicon ID read command (ABh) has been input). "Figure 11 Exiting from Power-down" shows the timing waveforms of the power-down exit command.

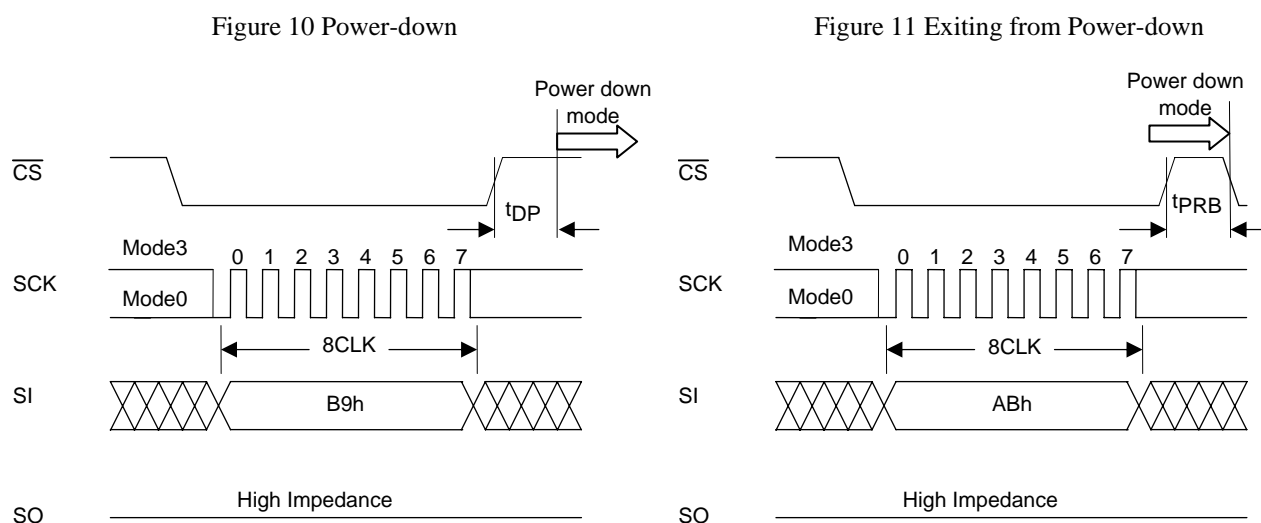

6. Small Sector Erase

Small sector erase is an operation that sets the memory cell data in any small sector to "1". A small sector consists of 4Kbytes. "Figure 12 Small Sector Erase" shows the timing waveforms, and Figure 21 shows a small sector erase flowchart. The small sector erase command consists of the first through fourth bus cycles, and it is initiated by inputting the 24-bit addresses following (D7h/20h). Addresses A17 to A12 are valid, and Addresses A23 to A18 are "don't care". After the command has been input, the internal erase operation starts from the rising \overline{CS} edge, and it ends automatically by the control exercised by the internal timer. Erase end can also be detected using status register \overline{RDY} .

Figure 12 Small Sector Erase

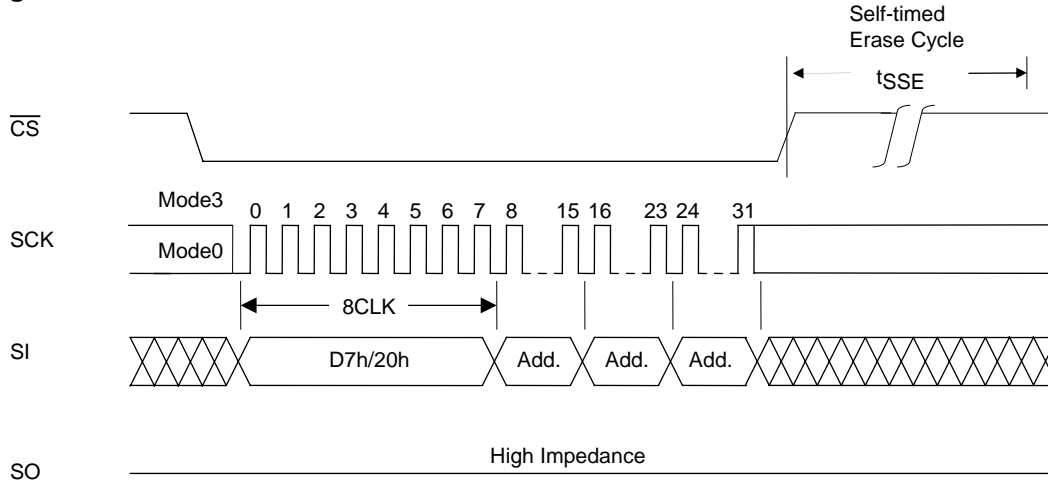

7. Sector Erase

Sector erase is an operation that sets the memory cell data in any sector to "1". A sector consists of 64Kbytes. "Figure 13 Sector Erase" shows the timing waveforms, and Figure 21 shows a sector erase flowchart. The sector erase command consists of the first through fourth bus cycles, and it is initiated by inputting the 24-bit addresses following (D8h). Addresses A17 to A16 are valid, and Addresses A23 to A18 are "don't care". After the command has been input, the internal erase operation starts from the rising \overline{CS} edge, and it ends automatically by the control exercised by the internal timer. Erase end can also be detected using status register \overline{RDY} .

Figure 13 Sector Erase

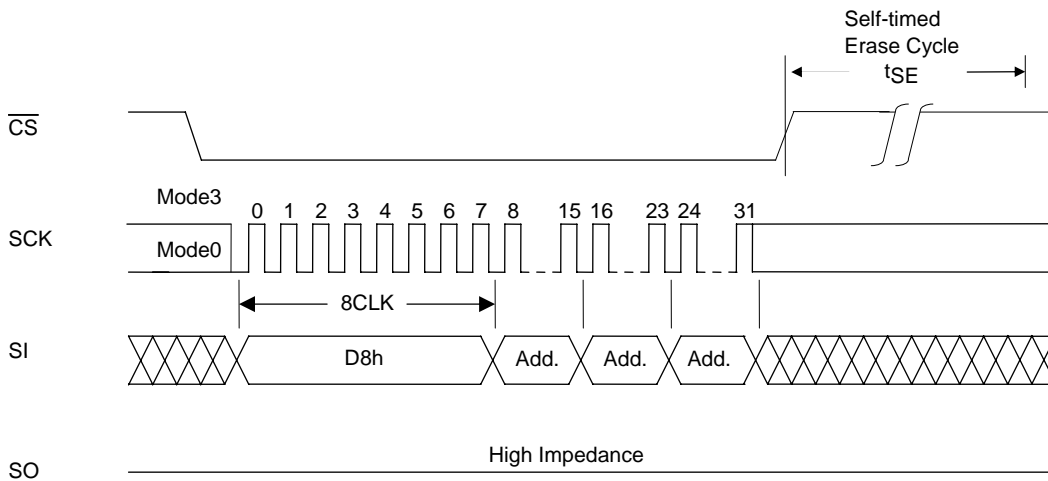

8. Chip Erase

Chip erase is an operation that sets the memory cell data in all the sectors to "1". "Figure 14 Chip Erase" shows the timing waveforms, and Figure 21 shows a chip erase flowchart. The chip erase command consists only of the first bus cycle, and it is initiated by inputting (C7h). After the command has been input, the internal erase operation starts from the rising \overline{CS} edge, and it ends automatically by the control exercised by the internal timer. Erase end can also be detected using status register \overline{RDY} .

Figure 14 Chip Erase

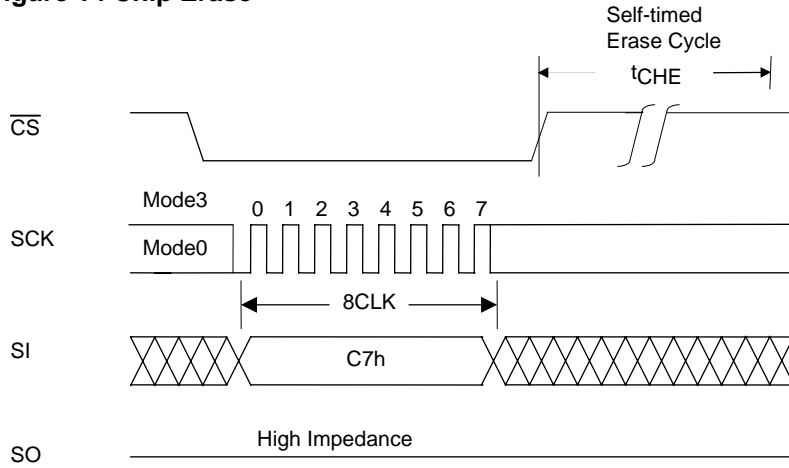

9. Page Program

Page program is an operation that programs any number of bytes from 1 to 256 bytes within the same sector page (page addresses: A17 to A8). Before initiating page program, the data on the page concerned must be erased using small sector erase, sector erase, or chip erase. "Figure 15 Page Program" shows the page program timing waveforms, and Figure 22 shows a page program flowchart. After the falling \overline{CS} edge, the command (02H) is input followed by the 24-bit addresses. Addresses A17 to A0 are valid. The program data is then loaded at each rising clock edge until the rising \overline{CS} edge, and data loading is continued until the rising \overline{CS} edge. If the data loaded has exceeded 256 bytes, the 256 bytes loaded last are programmed. The program data must be loaded in 1-byte increments, and the program operation is not performed at the rising \overline{CS} edge occurring at any other timing. The page program time is 2.0ms (typ.) when 256 bytes (1 page) are programmed at one time.

Figure 15 Page Program

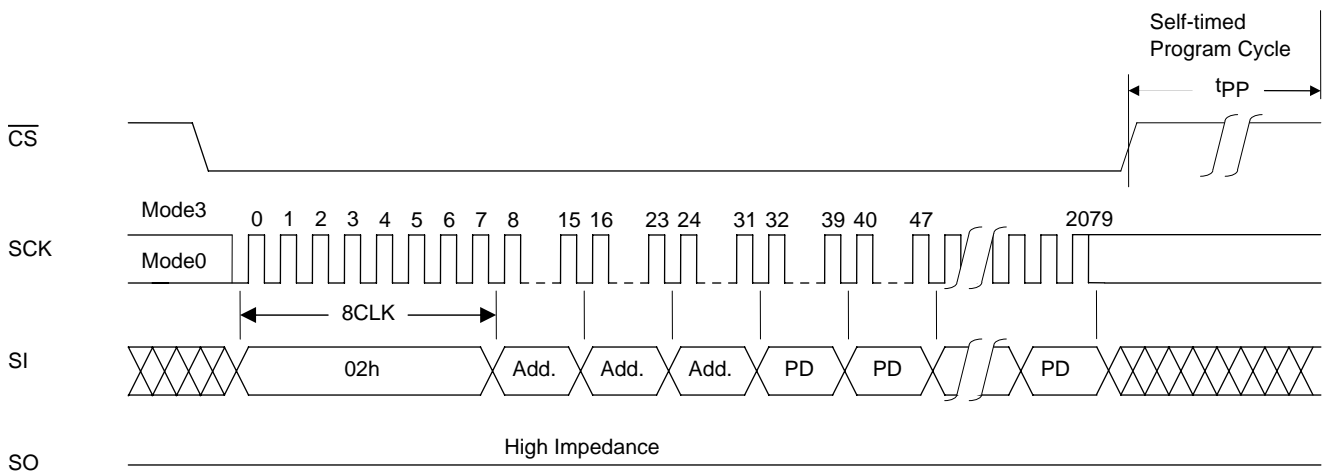

10. Silicon ID Read

Silicon ID read is an operation that reads the manufacturer code and device code information. The silicon ID read command is not accepted during writing.

Two methods are used for silicon ID reading. The first method involves inputting the 9Fh command: the setting is completed with only the first bus cycle input, and in subsequent bus cycles the manufacturer code 62h, 2 bytes of device ID code (Memory type, Memory capacity) and reserved code are repeatedly output in succession so long as the clock input is continued. Refer to "Figure 16-a Silicon ID Read 1" for the waveforms. "Table 6_1 Silicon ID Read 1" lists the silicon ID read1 codes.

The second method involves inputting the ABh command. This command consists of the first through fourth bus cycles, and the 1 byte silicon ID can be read when 24 dummy bits are input after (ABh). Refer to "Figure 16-b Silicon ID Read 2" for the waveforms. "Table 6_2 Silicon ID Read 2" lists the silicon ID read2 code. If, after the device code has been read, the SCK input is continued, the device code is output repeatedly.

The data is output starting with the falling clock edge of the fourth bus cycle bit 0, and silicon ID reading ends at the rising CS edge.

Table 6_1 Silicon ID Read 1

		Output Code
Manufacturer code		62h
2Byte Device ID	Memory Type	06h
	Memory Capacity code	12h(2MBit)
Reserved code		00h

Table 6_2 Silicon ID Read 2

	Output Code
1Byte Device ID	44h

Figure 16-a Silicon ID Read 1

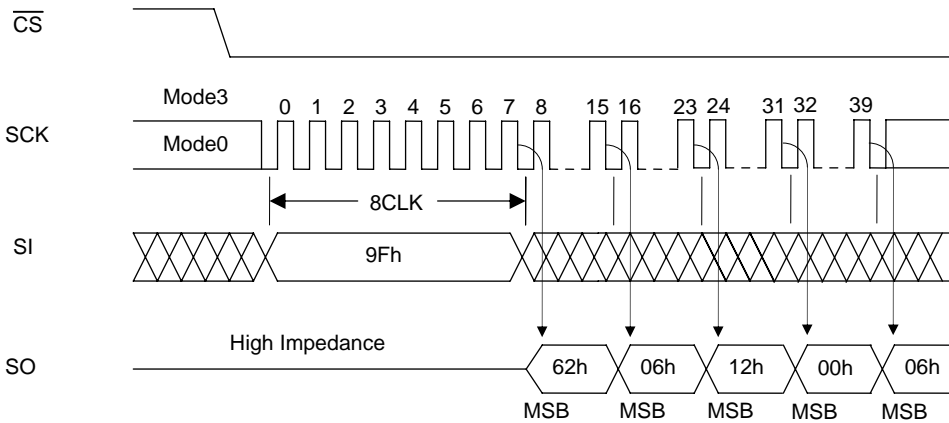
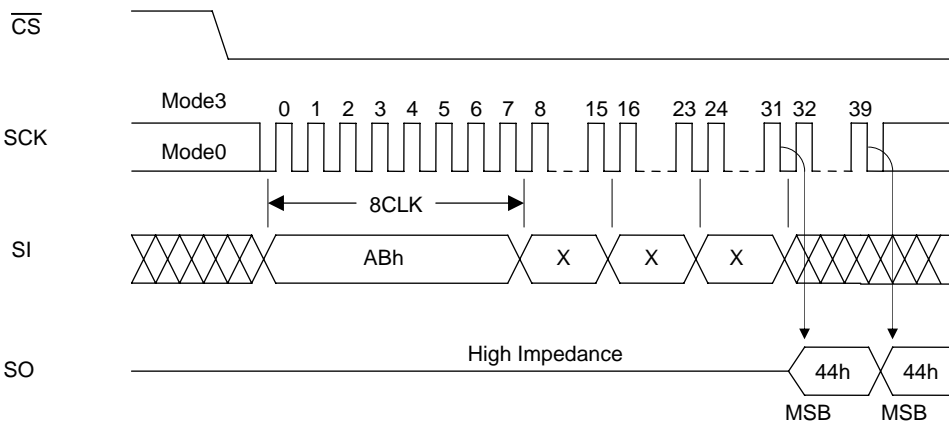

Figure 16-b Silicon ID Read 2



11. Hold Function

Using the $\overline{\text{HOLD}}$ pin, the hold function suspends serial communication (it places it in the hold status). "Figure 17 $\overline{\text{HOLD}}$ " shows the timing waveforms. The device is placed in the hold status at the falling $\overline{\text{HOLD}}$ edge while the logic level of SCK is low, and it exits from the hold status at the rising $\overline{\text{HOLD}}$ edge. When the logic level of SCK is high, $\overline{\text{HOLD}}$ must not rise or fall. The hold function takes effect when the logic level of $\overline{\text{CS}}$ is low, the hold status is exited and serial communication is reset at the rising $\overline{\text{CS}}$ edge. In the hold status, the SO output is in the high-impedance state, and SI and SCK are "don't care".

Figure 17 $\overline{\text{HOLD}}$

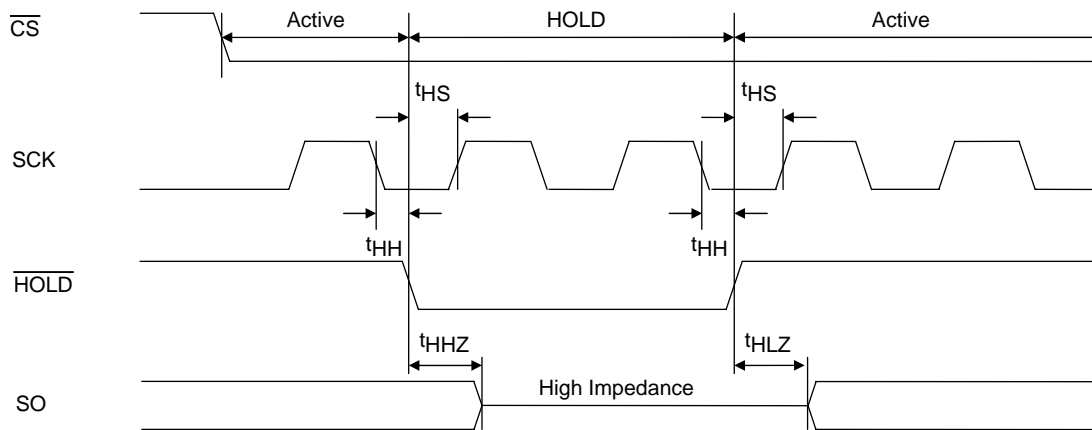

12. Power-on

In order to protect against unintentional writing, $\overline{\text{CS}}$ must be kept at V_{CC} At power-on. After power-on, the supply voltage has stabilized at 2.30V or higher, wait for 100 μs ($t_{\text{pU_READ}}$) before inputting the command to start a read operation. Similarly, wait for 10ms ($t_{\text{pU_WRITE}}$) after the voltage has stabilized before inputting the command to start a write operation.

Figure 18 Power-on Timing

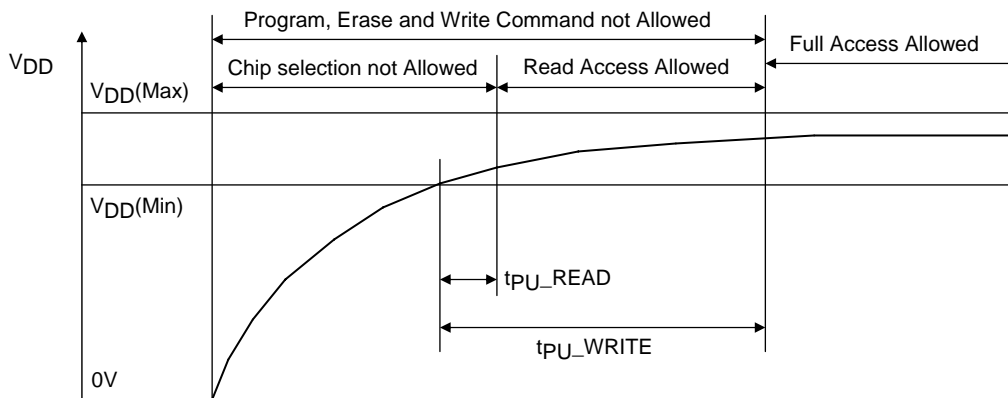

13. Hardware Data Protection

In order to protect against unintentional writing at power-on, the LE25U20AMB incorporates a power-on reset function. The following conditions must be met in order to ensure that the power reset circuit will operate stably. No guarantees are given for data in the event of an instantaneous power failure occurring during the writing period.

Figure 19 Power-down Timing

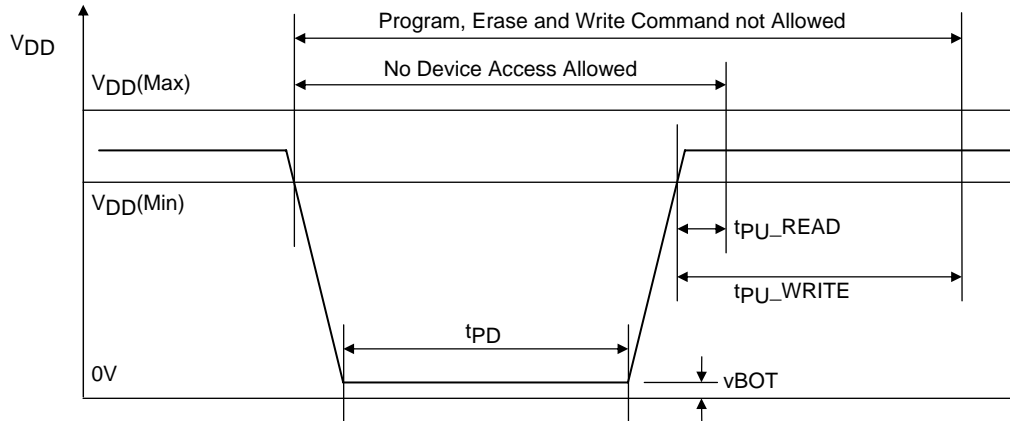

14. Software Data Protection

The LE25U20AMB eliminates the possibility of unintentional operations by not recognizing commands under the following conditions.

- When a write command is input and the rising \overline{CS} edge timing is not in a bus cycle (8 CLK units of SCK)
- When the page program data is not in 1-byte increments
- When the status register write command is input for 2 bus cycles or more

15. Decoupling Capacitor

A 0.1 μ F ceramic capacitor must be provided to each device and connected between V_{DD} and V_{SS} in order to ensure that the device will operate stably.

LE25U20AMB

Specifications

Absolute Maximum Ratings

Parameter	Symbol	Conditions	Ratings	unit
Maximum supply voltage	VDDmax	With respect to VSS	-0.5 to +4.6	V
DC voltage (all pins)	VIN/VOUT	With respect to VSS	-0.5 to VDD+0.5	V
Storage temperature	Tstg		-55 to +150	°C

Stresses exceeding Maximum Ratings may damage the device. Maximum Ratings are stress ratings only. Functional operation above the Recommended Operating Conditions is not implied. Extended exposure to stresses above the Recommended Operating Conditions may affect device reliability.

Operating Conditions

Parameter	Symbol	Conditions	Ratings	unit
Operating supply voltage	VDD		2.30 to 3.60	V
Operating ambient temperature	Topr		-40 to 85	°C

Allowable DC Operating Conditions

Parameter	Symbol	Conditions	Ratings			unit
			min	typ	max	
Read mode operating current	I _{CCR}	$\overline{CS}=0.1V_{DD}$, $\overline{HOLD}=\overline{WP}=0.9V_{DD}$ SI=0.1VDD/0.9VDD, SO=open operating frequency=30MHz, VDD=VDD max			6	mA
Write mode operating current (erase+page program)	I _{CCW}	VDD=VDD max, t _{SE} =40ms, t _{SE} =80ms, t _{CHE} =160ms, t _{pp} =5.0ms			15	mA
CMOS standby current	I _{SB}	$\overline{CS}=\overline{HOLD}=\overline{WP}=V_{DD}$, SI=VSS/VDD, SO=open, VDD=VDD max			50	μA
Power-down standby current	I _{DSB}	$\overline{CS}=\overline{HOLD}=\overline{WP}=V_{DD}$, SI=VSS/VDD, SO=open, VDD=VDD max			10	μA
Input leakage current	I _{LI}	VIN=VSS to VDD, VDD=VDD max			2	μA
Output leakage current	I _{LO}	VIN=VSS to VDD, VDD=VDD max			2	μA
Input low voltage	V _{IL}	VDD=VDD max	-0.3		0.3VDD	V
Input high voltage	V _{IH}	VDD=VDD min	0.7VDD		VDD+0.3	V
Output low voltage	V _{OL}	I _{OL} =100μA, VDD=VDD min			0.2	V
		I _{OL} =1.6mA, VDD=VDD min			0.4	
Output high voltage	V _{OH}	I _{OH} =-100μA, VDD=VDD min	VCC-0.2			V

Power-on Timing

Parameter	Symbol	Ratings		unit
		min	max	
Time from power-on to read operation	t _{PJ_READ}	100		μs
Time from power-on to write operation	t _{PJ_WRITE}	10		ms
Power-down time	t _{PD}	10		ms
Power-down voltage	V _{BOT}		0.2	V

Pin Capacitance at Ta=25°C, f=1MHz

Parameter	Symbol	Conditions	Ratings	unit
			max	
Output pin capacitance	C _{DQ}	V _{DQ} =0V	12	pF
Input pin capacitance	C _{IN}	V _{IN} =0V	6	pF

Note: These parameter values do not represent the results of measurements undertaken for all devices but rather values for some of the sampled devices.

LE25U20AMB

AC Characteristics

Parameter	Symbol	Ratings			unit
		min	typ	max	
Clock frequency	f _{CLK}			30	MHz
SCK logic high level pulse width	t _{CLHI}	16			ns
SCK logic low level pulse width	t _{CLLO}	16			ns
Input signal rising/falling time	t _{RF}			20	ns
$\overline{\text{CS}}$ setup time	t _{CSS}	10			ns
$\overline{\text{CS}}$ hold time	t _{CSH}	10			ns
Data setup time	t _{DS}	5			ns
Data hold time	t _{DH}	5			ns
$\overline{\text{CS}}$ wait pulse width	t _{CPH}	25			ns
Output high impedance time from $\overline{\text{CS}}$	t _{CHZ}			15	ns
Output data time from SCK	t _v		10	15	ns
Output data hold time	t _{HO}	1			ns
$\overline{\text{HOLD}}$ setup time	t _{HS}	7			ns
$\overline{\text{HOLD}}$ hold time	t _{HH}	3			ns
Output low impedance time from $\overline{\text{HOLD}}$	t _{HLZ}			9	ns
Output high impedance time from $\overline{\text{HOLD}}$	t _{HHZ}			9	ns
$\overline{\text{WP}}$ setup time	t _{WPS}	20			ns
$\overline{\text{WP}}$ hold time	t _{WPH}	20			ns
Write status register time	t _{SRW}		5	15	ms
Page programming cycle time	t _{PP}		4.0	5.0	ms
Small sector erase cycle time	t _{SSE}		0.04	0.15	s
Sector erase cycle time	t _{SE}		0.08	0.25	s
Chip erase cycle time	t _{CHE}		0.25	1.6	s
Power-down time	t _{DP}			3	μs
Power-down recovery time	t _{PRB}			3	μs
Output low impedance time from SCK	t _{CLZ}	0			ns

AC Test Conditions

Input pulse level..... 0V, 2.5V

Input rising/falling time.... 5ns

Input timing level..... 0.3V_{DD}, 0.7V_{DD}

Output timing level 1/2×V_{DD}

Output load 30pF

Note: As the test conditions for "typ," the measurements are conducted using 2.5V for V_{DD} at room temperature.

Figure 20 Status Register Write Flowchart

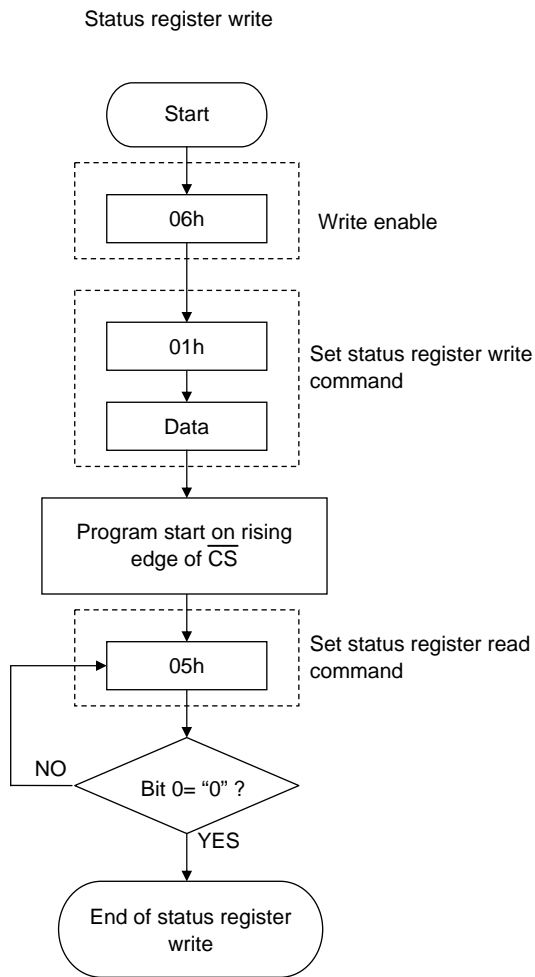

* Automatically placed in write disabled state at the end of the status register write

Figure 21 Erase Flowcharts

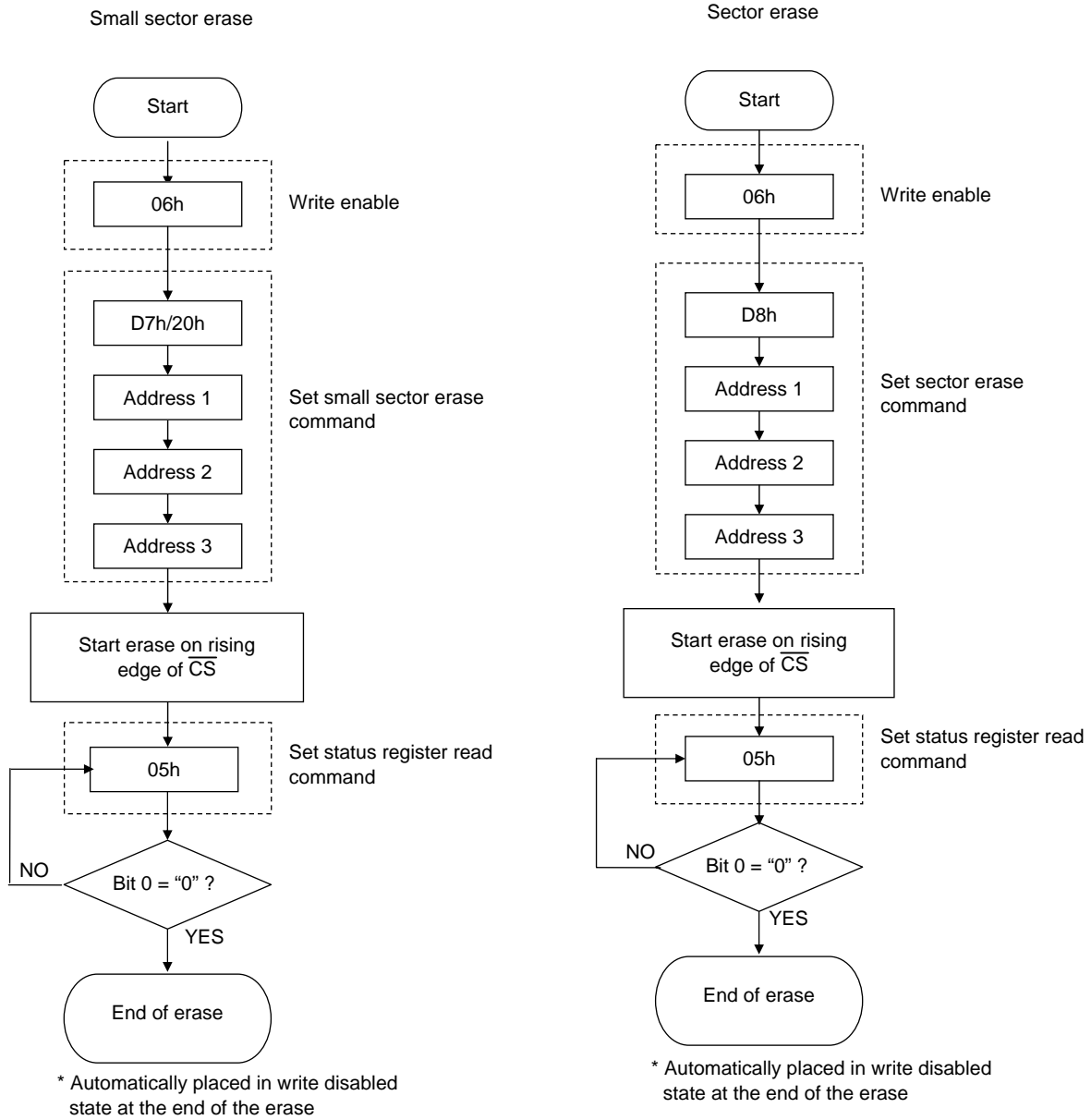
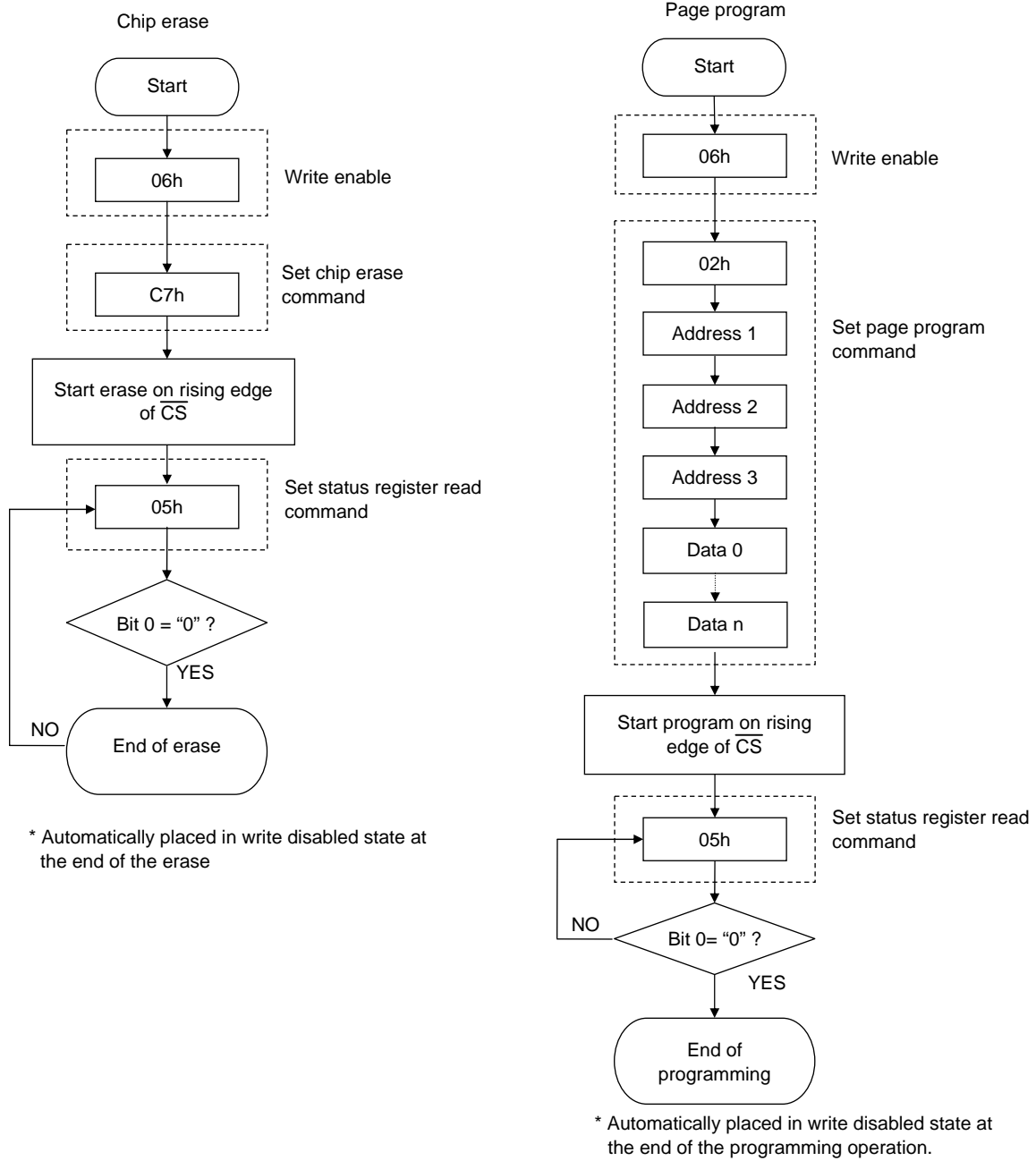

Figure 22 Page Program Flowchart



ON Semiconductor and the ON logo are registered trademarks of Semiconductor Components Industries, LLC (SCILLC). SCILLC owns the rights to a number of patents, trademarks, copyrights, trade secrets, and other intellectual property. A listing of SCILLC's product/patent coverage may be accessed at www.onsemi.com/site/pdf/Patent-Marking.pdf. SCILLC reserves the right to make changes without further notice to any products herein. SCILLC makes no warranty, representation or guarantee regarding the suitability of its products for any particular purpose, nor does SCILLC assume any liability arising out of the application or use of any product or circuit, and specifically disclaims any and all liability, including without limitation special, consequential or incidental damages. "Typical" parameters which may be provided in SCILLC data sheets and/or specifications can and do vary in different applications and actual performance may vary over time. All operating parameters, including "Typicals" must be validated for each customer application by customer's technical experts. SCILLC does not convey any license under its patent rights nor the rights of others. SCILLC products are not designed, intended, or authorized for use as components in systems intended for surgical implant into the body, or other applications intended to support or sustain life, or for any other application in which the failure of the SCILLC product could create a situation where personal injury or death may occur. Should Buyer purchase or use SCILLC products for any such unintended or unauthorized application, Buyer shall indemnify and hold SCILLC and its officers, employees, subsidiaries, affiliates, and distributors harmless against all claims, costs, damages, and expenses, and reasonable attorney fees arising out of, directly or indirectly, any claim of personal injury or death associated with such unintended or unauthorized use, even if such claim alleges that SCILLC was negligent regarding the design or manufacture of the part. SCILLC is an Equal Opportunity/Affirmative Action Employer. This literature is subject to all applicable copyright laws and is not for resale in any manner.

AMEYA360

Components Supply Platform

Authorized Distribution Brand :



Website :

Welcome to visit www.ameya360.com

Contact Us :

➤ Address :

401 Building No.5, JiuGe Business Center, Lane 2301, Yishan Rd
Minhang District, Shanghai , China

➤ Sales :

Direct +86 (21) 6401-6692

Email amall@ameya360.com

QQ 800077892

Skype [ameyasales1](#) [ameyasales2](#)

➤ Customer Service :

Email service@ameya360.com

➤ Partnership :

Tel +86 (21) 64016692-8333

Email mkt@ameya360.com