

# FAN7621B

## PFM Controller for Half-Bridge Resonant Converters

### Features

- Variable Frequency Control with 50% Duty Cycle for Half-bridge Resonant Converter Topology
- High Efficiency through Zero Voltage Switching (ZVS)
- Fixed Dead Time (350ns)
- Up to 300kHz Operating Frequency
- Pulse Skipping for Frequency Limit (Programmable) at Light-Load Condition
- Remote On/Off Control using CON Pin
- Protection Functions: Over-Voltage Protection (OVP), Overload Protection (OLP), Over-Current Protection (OCP), Abnormal Over-Current Protection (AOCP), Internal Thermal Shutdown (TSD)

### Applications

- PDP and LCD TVs
- Desktop PCs and Servers
- Adapters
- Telecom Power Supplies
- Video Game Consoles

### Description

The FAN7621B is a pulse frequency modulation controller for high-efficiency half-bridge resonant converters. Offering everything necessary to build a reliable and robust resonant converter, the FAN7621B simplifies designs and improves productivity, while improving performance. The FAN7621B includes a high-side gate-drive circuit, an accurate current controlled oscillator, frequency limit circuit, soft-start, and built-in protection functions. The high-side gate-drive circuit has a common-mode noise cancellation capability, which guarantees stable operation with excellent noise immunity. Using the zero-voltage-switching (ZVS) technique dramatically reduces the switching losses and efficiency is significantly improved. The ZVS also reduces the switching noise noticeably, which allows a small-sized Electromagnetic Interference (EMI) filter.

The FAN7621B can be applied to various resonant converter topologies; such as series resonant, parallel resonant, and LLC resonant converters.

### Related Resources

[AN4151 — Half-bridge LLC Resonant Converter Design using FSFR-series Fairchild Power Switch \(FPS™\)](#)

### Ordering Information

Part Number	Operating Junction Temperature	Package	Packaging Method
FAN7621BSJ	-40°C ~ 130°C	16-Lead Small Outline Package (SOP)	Tube
FAN7621BSJX			Tape & Reel

### Application Circuit Diagram

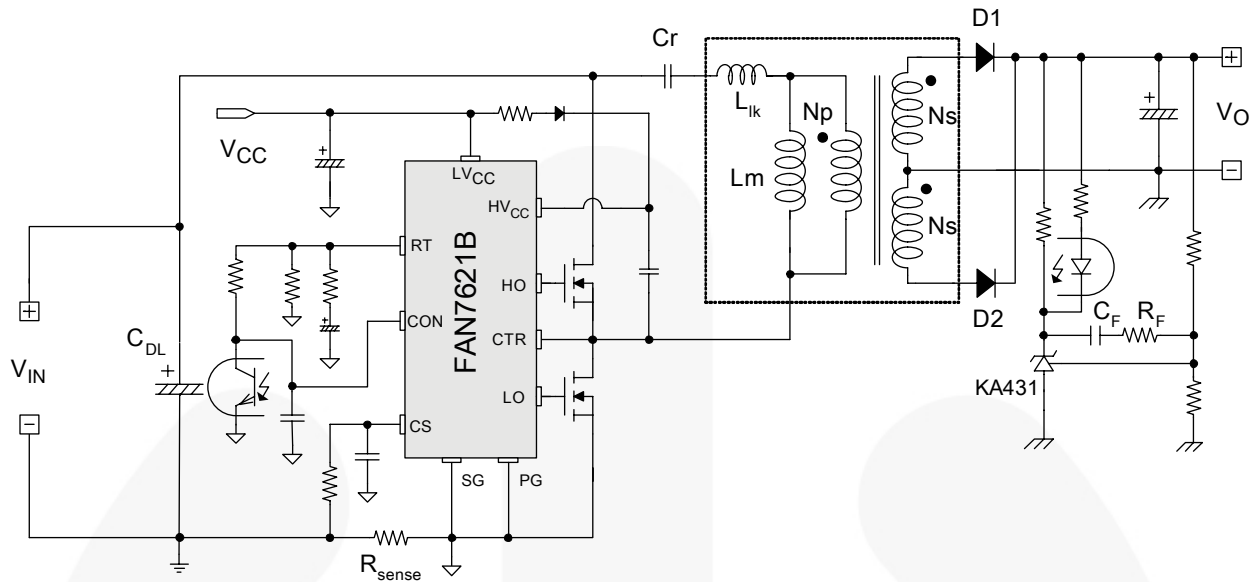


Figure 1. Typical Application Circuit (LLC Resonant Half-Bridge Converter)

### Block Diagram

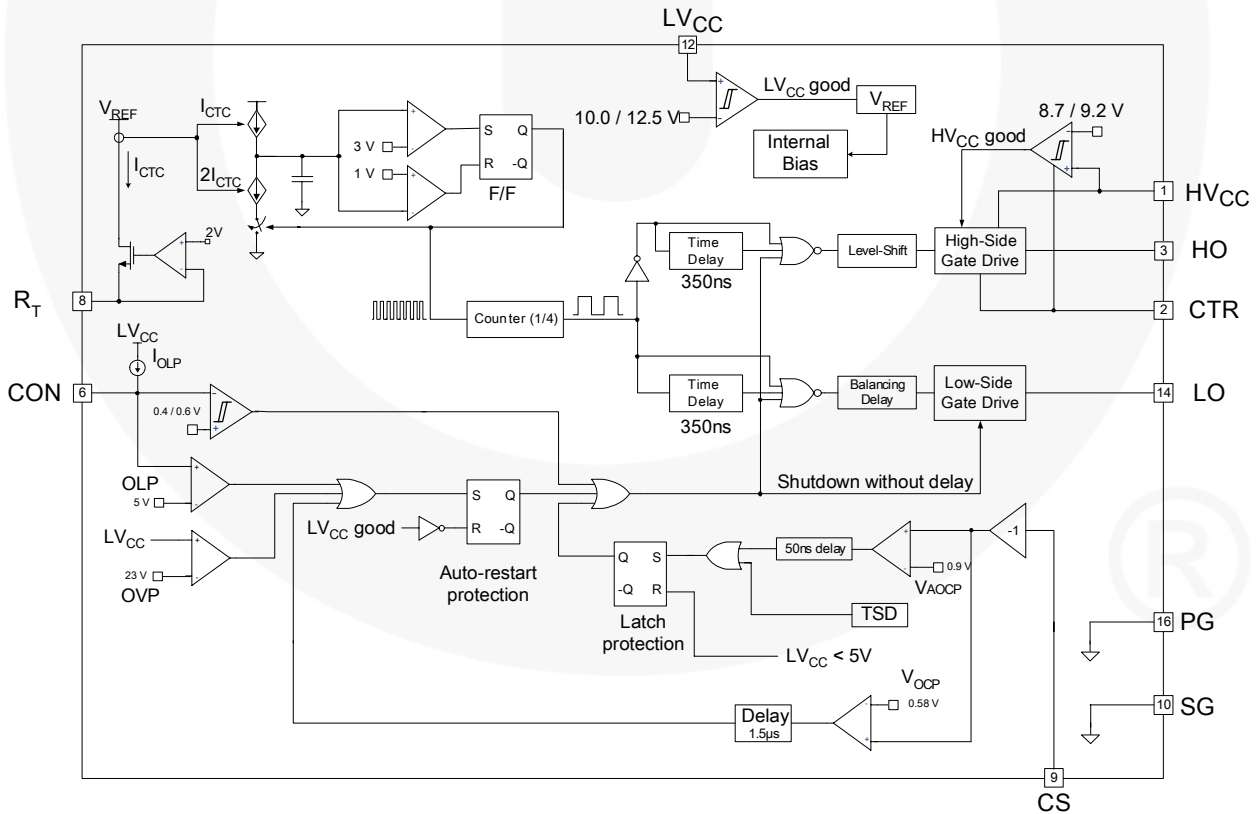


Figure 2. Internal Block Diagram

## Pin Configuration

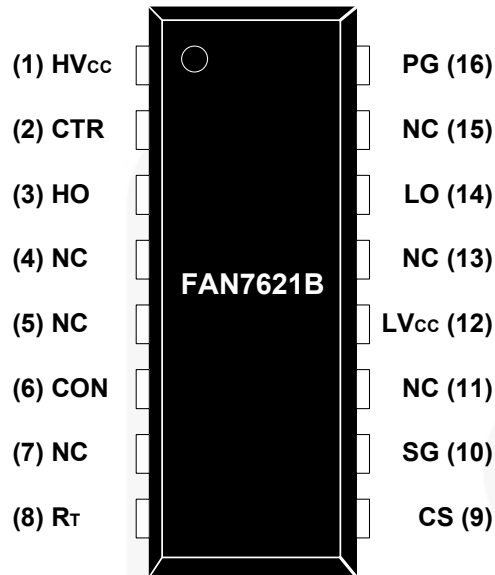


Figure 3. Package Diagram

## Pin Definitions

Pin #	Name	Description
1	HV <sub>CC</sub>	This is the supply voltage of the high-side gate-drive circuit IC.
2	CTR	This is the drain of the low-side MOSFET. Typically, a transformer is connected to this pin.
3	HO	This is the high-side gate driving signal.
4	NC	No connection.
5	NC	No connection.
6	CON	This pin is for a protection and enabling/disabling the controller. When the voltage of this pin is above 0.6V, the IC operation is enabled. When the voltage of this pin drops below 0.4V, gate drive signals for both MOSFETs are disabled. When the voltage of this pin increases above 5V, protection is triggered.
7	NC	No connection.
8	R <sub>T</sub>	This pin programs the switching frequency. Typically, an opto-coupler is connected to control the switching frequency for the output voltage regulation.
9	CS	This pin senses the current flowing through the low-side MOSFET. Typically, negative voltage is applied on this pin.
10	SG	This pin is the control ground.
11	NC	No connection.
12	LV <sub>CC</sub>	This pin is the supply voltage of the control IC.
13	NC	No connection.
14	LO	This is the low-side gate driving signal.
15	NC	No connection.
16	PG	This pin is the power ground. This pin is connected to the source of the low-side MOSFET.

## Absolute Maximum Ratings

Stresses exceeding the absolute maximum ratings may damage the device. The device may not function or be operable above the recommended operating conditions and stressing the parts to these levels is not recommended. In addition, extended exposure to stresses above the recommended operating conditions may affect device reliability. The absolute maximum ratings are stress ratings only.  $T_A=25^{\circ}\text{C}$  unless otherwise specified.

Symbol	Parameter	Min.	Max.	Unit
$V_{HO}$	High-Side Gate Driving Voltage	$V_{CTR}-0.3$	$HV_{CC}$	V
$V_{LO}$	Low-Side Gate Driving Voltage	-0.3	$LV_{CC}$	
$LV_{CC}$	Low-Side Supply Voltage	-0.3	25.0	V
$HV_{CC}$ to $V_{CTR}$	High-Side $V_{CC}$ Pin to Center Voltage	-0.3	25.0	V
$V_{CTR}$	Center Voltage	-0.3	600.0	V
$V_{CON}$	Control Pin Input Voltage	-0.3	$LV_{CC}$	V
$V_{CS}$	Current Sense (CS) Pin Input Voltage	-5.0	1.0	V
$V_{RT}$	$R_T$ Pin Input Voltage	-0.3	5.0	V
$dV_{CTR}/dt$	Allowable Center Voltage Slew Rate		50	V/ns
$P_D$	Total Power Dissipation			W
	16-SOP		1.13	
$T_J$	Maximum Junction Temperature <sup>(1)</sup>		+150	$^{\circ}\text{C}$
	Recommended Operating Junction Temperature <sup>(1)</sup>	-40	+130	
$T_{STG}$	Storage Temperature Range	-55	+150	$^{\circ}\text{C}$

### Note:

- The maximum value of the recommended operating junction temperature is limited by thermal shutdown.

## Thermal Impedance

Symbol	Parameter	Value	Unit
$\theta_{JA}$	Junction-to-Ambient Thermal Impedance	16-SOP	$^{\circ}\text{C}/\text{W}$

## Electrical Characteristics

$T_A=25^\circ\text{C}$  and  $LV_{CC}=17\text{V}$  unless otherwise specified.

Symbol	Parameter	Test Conditions	Min.	Typ.	Max.	Unit
<b>Supply Section</b>						
$I_{LK}$	Offset Supply Leakage Current	$HV_{CC}=V_{CTR}$			50	$\mu\text{A}$
$I_{QHVC}$	Quiescent $HV_{CC}$ Supply Current	$(HV_{CCUV+}) - 0.1\text{V}$		50	120	$\mu\text{A}$
$I_{QLVCC}$	Quiescent $LV_{CC}$ Supply Current	$(LV_{CCUV+}) - 0.1\text{V}$		100	200	$\mu\text{A}$
$I_{OHVC}$	Operating $HV_{CC}$ Supply Current (RMS Value)	$f_{OSC}=100\text{kHz}$ , $V_{CON} > 0.6\text{V}$ , $C_{Load}=1\text{nF}$		5	8	$\text{mA}$
		No Switching, $V_{CON} < 0.4\text{V}$		100	200	$\mu\text{A}$
$I_{OLVCC}$	Operating $LV_{CC}$ Supply Current (RMS Value)	$f_{OSC}=100\text{kHz}$ , $V_{CON} > 0.6\text{V}$ , $C_{Load}=1\text{nF}$		6	9	$\text{mA}$
		No Switching, $V_{CON} < 0.4\text{V}$		2	4	$\text{mA}$
<b>UVLO Section</b>						
$LV_{CCUV+}$	$LV_{CC}$ Supply Under-Voltage Positive Going Threshold ( $LV_{CC}$ Start)		11.2	12.5	13.8	V
$LV_{CCUV-}$	$LV_{CC}$ Supply Under-Voltage Negative Going Threshold ( $LV_{CC}$ Stop)		8.90	10.00	11.10	V
$LV_{CCUVH}$	$LV_{CC}$ Supply Under-Voltage Hysteresis			2.5		V
$HV_{CCUV+}$	$HV_{CC}$ Supply Under-Voltage Positive Going Threshold ( $HV_{CC}$ Start)		8.2	9.2	10.2	V
$HV_{CCUV-}$	$HV_{CC}$ Supply Under-Voltage Negative Going Threshold ( $HV_{CC}$ Stop)		7.8	8.7	9.6	V
$HV_{CCUVH}$	$HV_{CC}$ Supply Under-Voltage Hysteresis			0.5		V
<b>Oscillator &amp; Feedback Section</b>						
$V_{CONDIS}$	Control Pin Disable Threshold Voltage		0.36	0.40	0.44	V
$V_{CONEN}$	Control Pin Enable Threshold Voltage		0.54	0.60	0.66	V
$V_{RT}$	V-I Converter Threshold Voltage		1.5	2.0	2.5	V
$f_{OSC}$	Output Oscillation Frequency	$R_T=5.2\text{k}\Omega$	94	100	106	$\text{kHz}$
DC	Output Duty Cycle		48	50	52	%
$f_{SS}$	Internal Soft-Start Initial Frequency	$f_{SS}=f_{OSC}+40\text{kHz}$ , $R_T=5.2\text{k}\Omega$		140		$\text{kHz}$
$t_{SS}$	Internal Soft-Start Time		2	3	4	ms
<b>Output Section</b>						
$I_{source}$	Peak Sourcing Current	$HV_{CC}=17\text{V}$	250	360		$\text{mA}$
$I_{sink}$	Peak Sinking Current	$HV_{CC}=17\text{V}$	460	600		$\text{mA}$
$t_r$	Rising Time	$C_{Load}=1\text{nF}$ , $HV_{CC}=17\text{V}$		65		ns
$t_f$	Falling Time			35		ns
$V_{HOH}$	High Level of High-Side Gate Driving Signal ( $V_{HVCC}-V_{HO}$ )	$I_O=20\text{mA}$			1.0	V
$V_{HOL}$	Low Level of High-Side Gate Driving Signal				0.6	V
$V_{LOH}$	High Level of High-Side Gate Driving Signal ( $V_{LVCC}-V_{LO}$ )				1.0	V
$V_{LOL}$	Low Level of High-Side Gate Driving Signal				0.6	V

**Electrical Characteristics** (Continued)T<sub>A</sub>=25°C and LV<sub>CC</sub>=17V unless otherwise specified.

Symbol	Parameter	Test Conditions	Min.	Typ.	Max.	Unit
<b>Protection Section</b>						
I <sub>OLP</sub>	OLP Delay Current	V <sub>CON</sub> =4V	3.8	5.0	6.2	μA
V <sub>OLP</sub>	OLP Protection Voltage	V <sub>CON</sub> > 3.5V	4.5	5.0	5.5	V
V <sub>OVP</sub>	LV <sub>CC</sub> Over-Voltage Protection	LV <sub>CC</sub> > 21V	21	23	25	V
V <sub>AOCP</sub>	AOCP Threshold Voltage		-1.0	-0.9	-0.8	V
t <sub>BAO</sub>	AOCP Blanking Time			50		ns
V <sub>OCP</sub>	OCP Threshold Voltage		-0.64	-0.58	-0.52	V
t <sub>BO</sub>	OCP Blanking Time <sup>(2)</sup>		1.0	1.5	2.0	μs
t <sub>DA</sub>	Delay Time (Low-Side) Detecting from V <sub>AOCP</sub> to Switch Off <sup>(2)</sup>			250	400	ns
T <sub>SD</sub>	Thermal Shutdown Temperature <sup>(2)</sup>		110	130	150	°C
I <sub>SU</sub>	Protection Latch Sustain LV <sub>CC</sub> Supply Current	LV <sub>CC</sub> =7.5V		100	150	μA
V <sub>PRSET</sub>	Protection Latch Reset LV <sub>CC</sub> Supply Voltage		5			V
<b>Dead-Time Control Section</b>						
D <sub>T</sub>	Dead Time			350		ns

**Note:**

- These parameters, although guaranteed, are not tested in production.

## Typical Performance Characteristics

These characteristic graphs are normalized at  $T_A=25^\circ\text{C}$ .

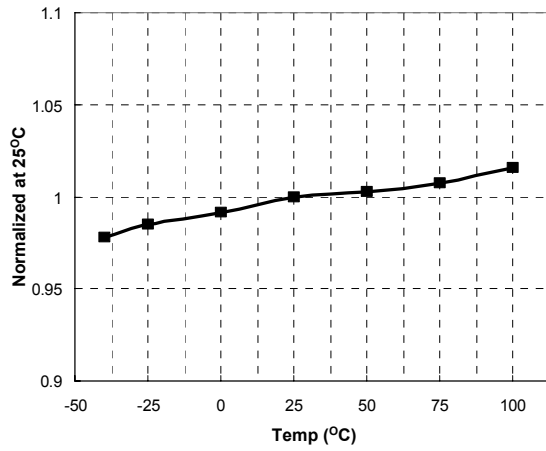


Figure 4. Low-Side MOSFET Duty Cycle vs. Temperature

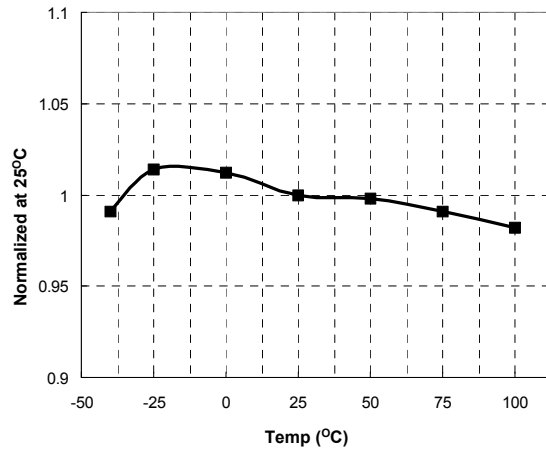


Figure 5. Switching Frequency vs. Temperature

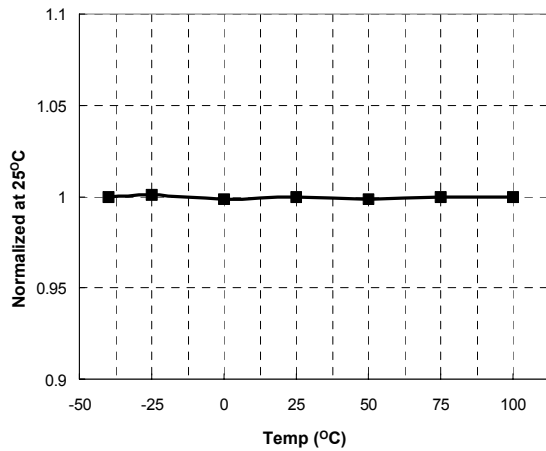


Figure 6. High-Side  $V_{CC}$  ( $HV_{CC}$ ) Start vs. Temperature

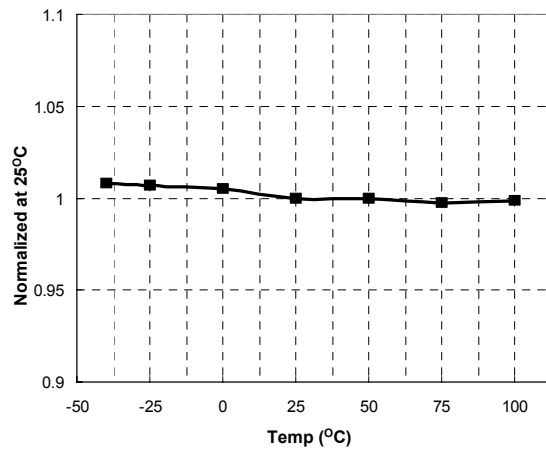


Figure 7. High-Side  $V_{CC}$  ( $HV_{CC}$ ) Stop vs. Temperature

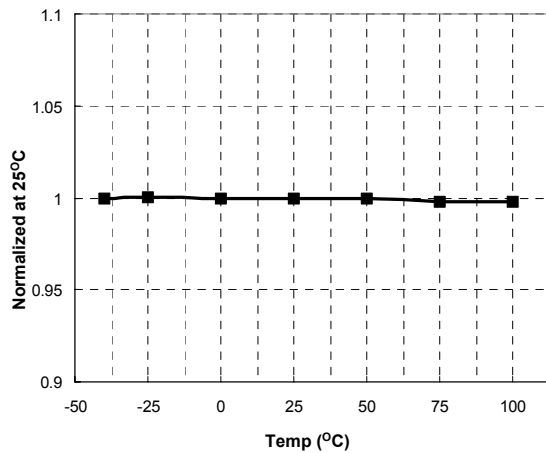


Figure 8. Low-Side  $V_{CC}$  ( $LV_{CC}$ ) Start vs. Temperature

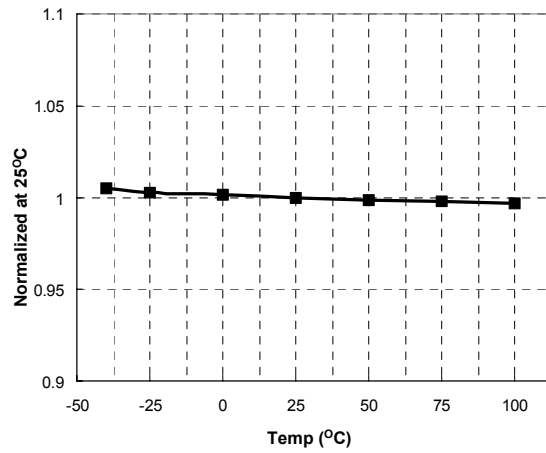


Figure 9. Low-Side  $V_{CC}$  ( $LV_{CC}$ ) Stop vs. Temperature

## Typical Performance Characteristics (Continued)

These characteristic graphs are normalized at  $T_A=25^\circ\text{C}$ .

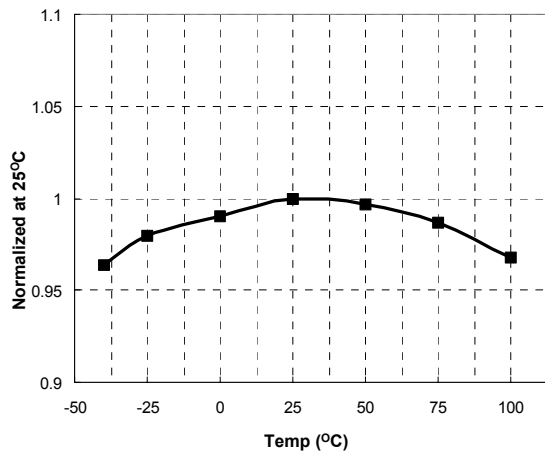


Figure 10. OLP Delay Current vs. Temperature

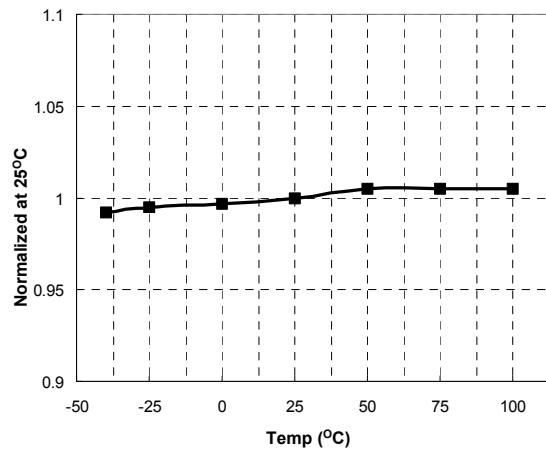


Figure 11. OLP Protection Voltage vs. Temperature

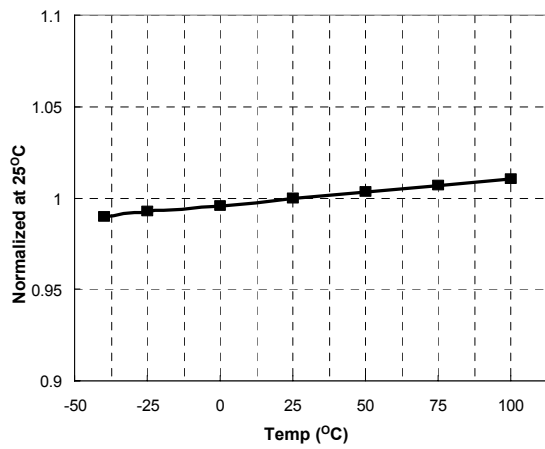


Figure 12. LV<sub>CC</sub> OVP Voltage vs. Temperature

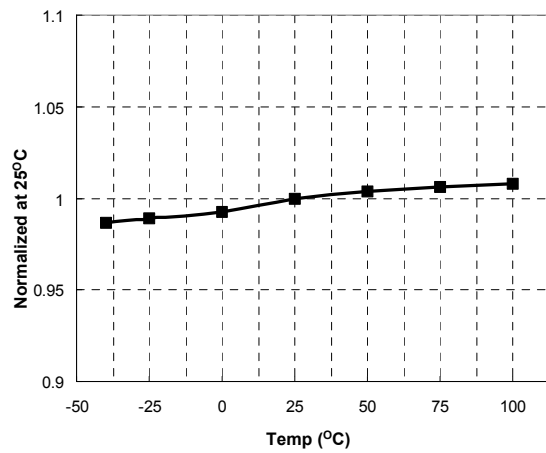


Figure 13. R<sub>T</sub> Voltage vs. Temperature

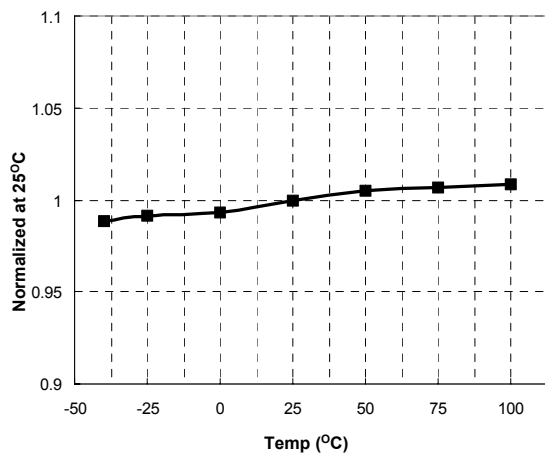


Figure 14. CON Pin Enable Voltage vs. Temperature

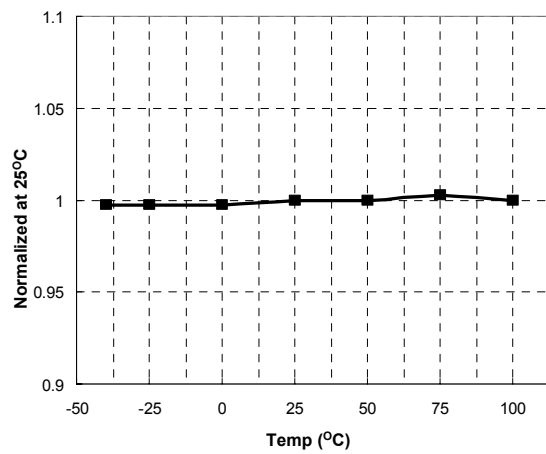


Figure 15. OCP Voltage vs. Temperature

## Functional Description

**1. Basic Operation:** FAN7621B is designed to drive high-side and low-side MOSFETs complementarily with 50% duty cycle. A fixed dead time of 350ns is introduced between consecutive transitions, as shown in Figure 16.

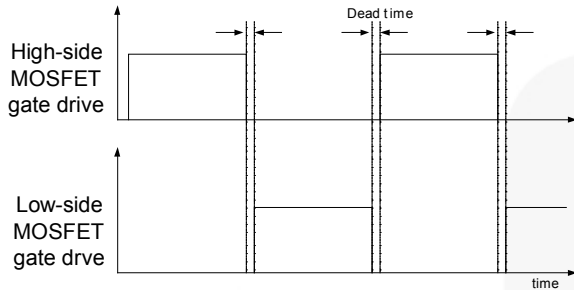


Figure 16. MOSFETs Gate Drive Signal

**2. Internal Oscillator:** FAN7621B employs a current-controlled oscillator, as shown in Figure 17. Internally, the voltage of  $R_T$  pin is regulated at 2V and the charging / discharging current for the oscillator capacitor,  $C_T$ , is obtained by copying the current flowing out of  $R_T$  pin ( $I_{CTC}$ ) using a current mirror. Therefore, the switching frequency increases as  $I_{CTC}$  increases.

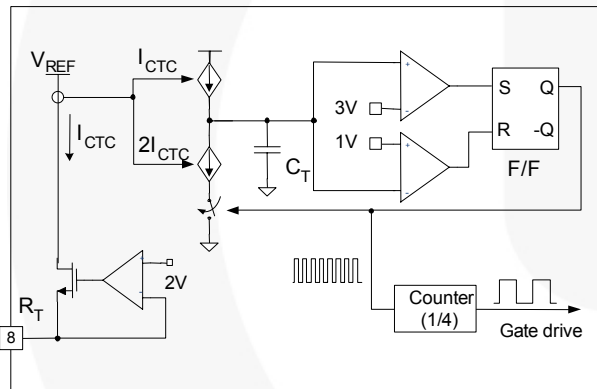


Figure 17. Current Controlled Oscillator

**3. Frequency Setting:** Figure 18 shows the typical voltage gain curve of a resonant converter, where the gain is inversely proportional to the switching frequency in the ZVS region. The output voltage can be regulated by modulating the switching frequency. Figure 19 shows the typical circuit configuration for  $R_T$  pin, where the opto-coupler transistor is connected to the  $R_T$  pin to modulate the switching frequency.

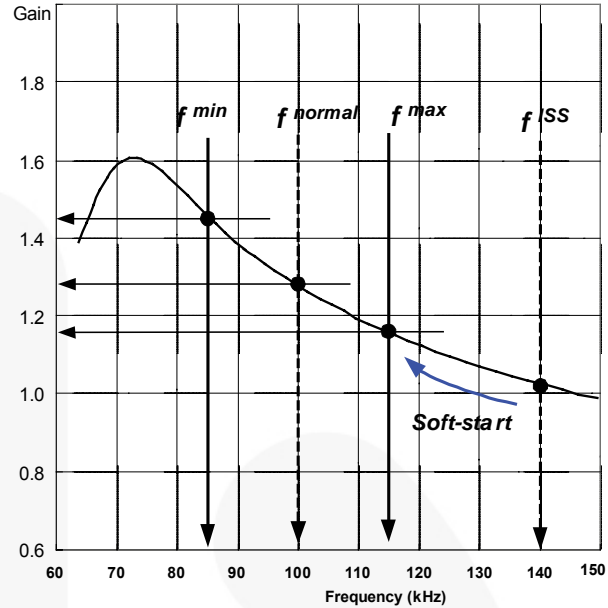


Figure 18. Resonant Converter Typical Gain Curve

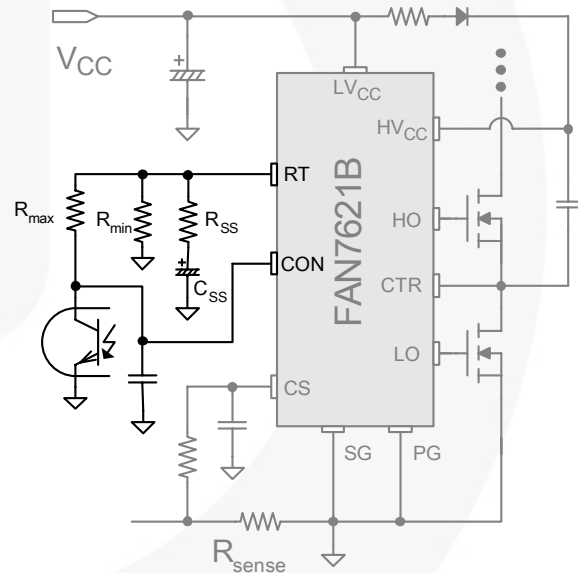


Figure 19. Frequency Control Circuit

The minimum switching frequency is determined as:

$$f^{\min} = \frac{5.2k\Omega}{R_{\min}} \times 100(kHz) \quad (1)$$

Assuming the saturation voltage of opto-coupler transistor is 0.2V, the maximum switching frequency is determined as:

$$f^{\max} = \left( \frac{5.2k\Omega}{R_{\min}} + \frac{4.68k\Omega}{R_{\max}} \right) \times 100(kHz) \quad (2)$$

To prevent excessive inrush current and overshoot of output voltage during startup, increase the voltage gain of the resonant converter progressively. Since the voltage gain of the resonant converter is inversely

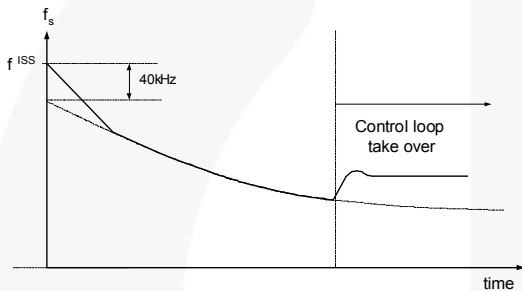
proportional to the switching frequency, the soft-start is implemented by sweeping down the switching frequency from an initial high frequency ( $f^{ISS}$ ) until the output voltage is established. The soft-start circuit is made by connecting R-C series network on the  $R_T$  pin, as shown in Figure 19. FAN7621B also has an internal soft-start for 3ms to reduce the current overshoot during the initial cycles, which adds 40kHz to the initial frequency of the external soft-start circuit, as shown in Figure 20. The initial frequency of the soft-start is given as:

$$f^{ISS} = \left( \frac{5.2k\Omega}{R_{min}} + \frac{5.2k\Omega}{R_{SS}} \right) \times 100 + 40 \text{ (kHz)} \quad (3)$$

It is typical to set the initial (soft-start) frequency of two ~ three times the resonant frequency ( $f_0$ ) of the resonant network.

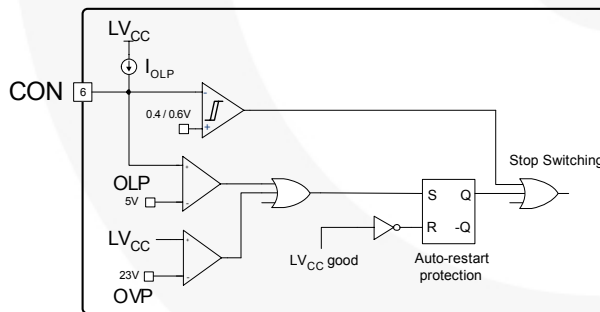
The soft-start time is three to four times the RC time constant. The RC time constant is as follows:

$$T_{SS} = R_{SS} \cdot C_{SS} \quad (4)$$



**Figure 20. Frequency Sweeping of Soft-Start**

**4. Control Pin:** The FAN7621B has a control pin for protection, cycle skipping, and remote on/off. Figure 21 shows the internal block diagram for control pin.

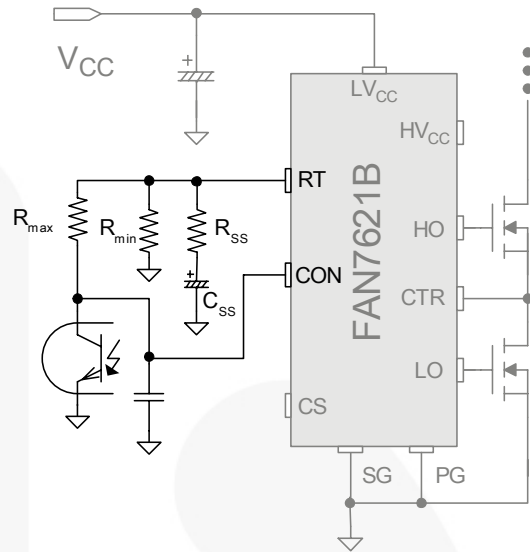


**Figure 21. Internal Block of Control Pin**

**Protection:** When the control pin voltage exceeds 5V, protection is triggered. Detailed applications are described in the protection section.

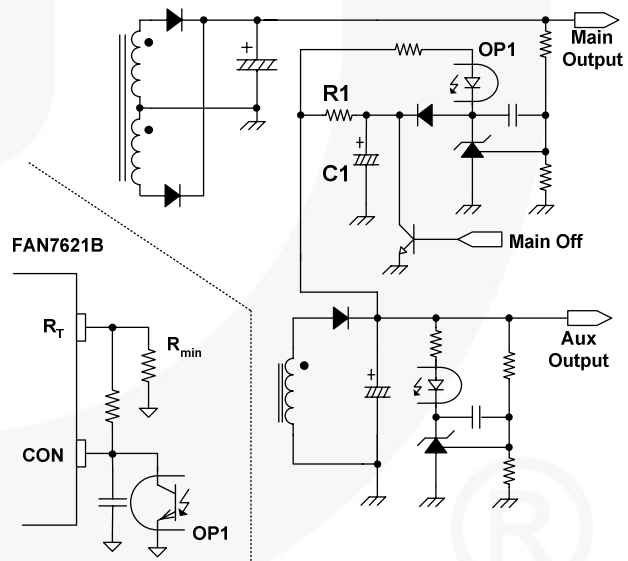
**Pulse Skipping:** FAN7621B stops switching when the control pin voltage drops below 0.4V and resumes switching when the control pin voltage rises above 0.6V. To use pulse-skipping, the control pin should be connected to the opto-coupler collector pin. The frequency that causes pulse skipping is given as:

$$f^{SKIP} = \left( \frac{5.2k\Omega}{R_{min}} + \frac{4.16k\Omega}{R_{max}} \right) \times 100 \text{ (kHz)} \quad (5)$$



**Figure 22. Control Pin Configuration for Pulse Skipping**

**Remote On / Off:** When an auxiliary power supply is used for standby, the main power stage using FAN7621B can be shut down by pulling down the control pin voltage, as shown in Figure 23. R1 and C1 are used to ensure soft-start when switching resumes.

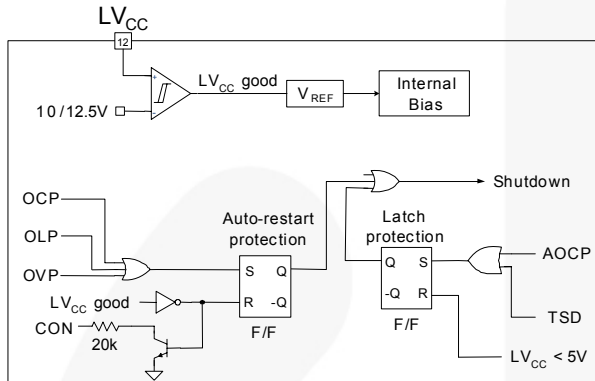


**Figure 23. Remote On / Off Circuit**

**5. Protection Circuits:** The FAN7621B has several self-protective functions, such as Overload Protection (OLP), Over-Current Protection (OCP), Abnormal Over-Current Protection (AOCP), Over-Voltage Protection (OVP), and Thermal Shutdown (TSD). OLP, OCP, and OVP are auto-restart mode protections; while AOCP and TSD are latch-mode protections, as shown in Figure 24.

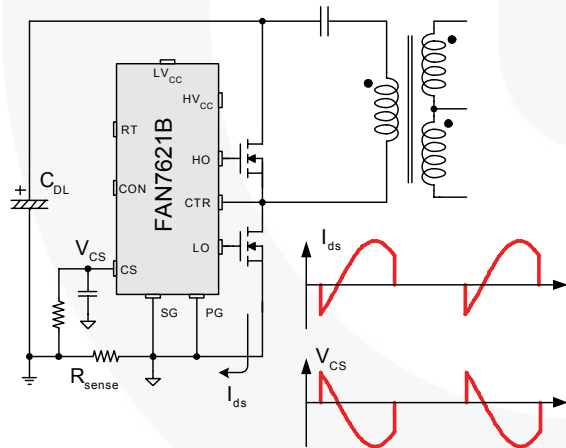
**Auto-Restart Mode Protection:** Once a fault condition is detected, switching is terminated and the MOSFETs remain off. When LV<sub>CC</sub> falls to the LV<sub>CC</sub> stop voltage of 10.0V, the protection is reset. FAN7621B resumes normal operation when LV<sub>CC</sub> reaches the start voltage of 12.5V.

**Latch-Mode Protection:** Once this protection is triggered, switching is terminated and the gate output signals remain off. The latch is reset only when LV<sub>CC</sub> is discharged below 5V.

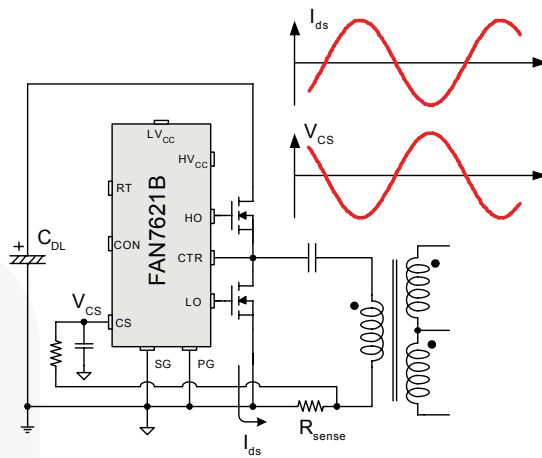


**Figure 24. Protection Blocks**

**Current Sensing Using Resistor:** FAN7621B senses drain current as a negative voltage, as shown in Figure 25 and Figure 26. Half-wave sensing allows low power dissipation in the sensing resistor, while full-wave sensing has less switching noise in the sensing signal.



**Figure 25. Half-Wave Sensing**

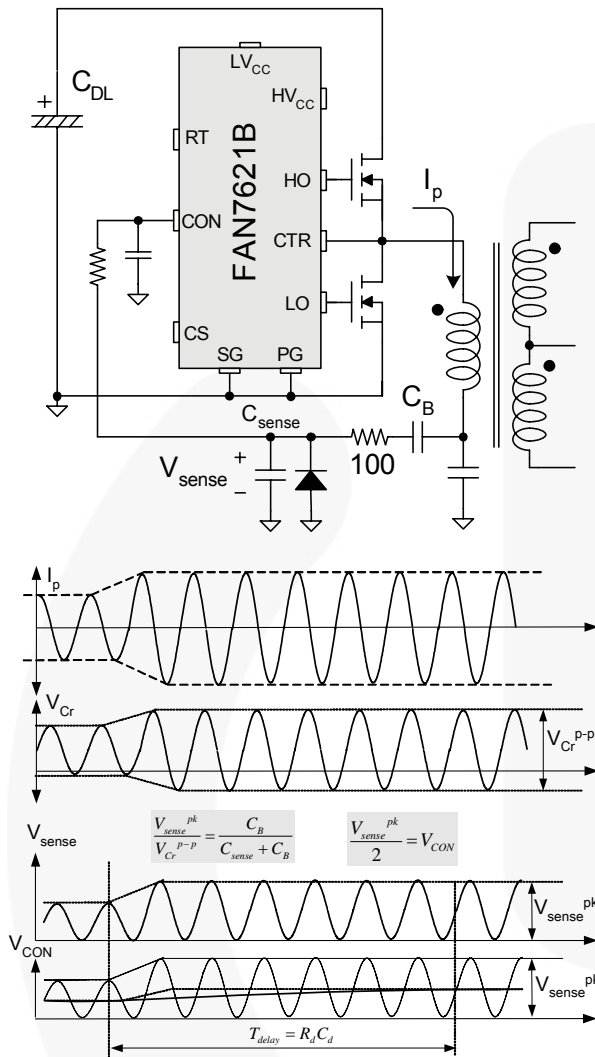


**Figure 26. Full-Wave Sensing**

**Current Sensing Using Resonant Capacitor Voltage:** For high-power applications, current sensing using a resistor may not be available due to the severe power dissipation in the resistor. In that case, indirect current sensing using the resonant capacitor voltage can be a good alternative because the amplitude of the resonant capacitor voltage ( $V_{cr}^{p-p}$ ) is proportional to the resonant current in the primary side ( $I_p^{p-p}$ ) as:

$$V_{Cr}^{p-p} = \frac{I_p^{p-p}}{2\pi f_s C_r} \quad (6)$$

To minimize power dissipation, a capacitive voltage divider is generally used for capacitor voltage sensing, as shown in Figure 27.



**Figure 27. Current Sensing Using Resonant Capacitor Voltage**

**5.1 Over-Current Protection (OCP):** When the sensing pin voltage drops below -0.6V, OCP is triggered and the MOSFETs remain off. This protection has a shutdown time delay of 1.5µs to prevent premature shutdown during startup.

**5.2 Abnormal Over-Current Protection: (AOCP):** If the secondary rectifier diodes are shorted, large current with extremely high di/dt can flow through the MOSFET before OCP or OLP is triggered. AOCP is triggered without shutdown delay when the sensing pin voltage drops below -0.9V. This protection is latch mode and reset when LV<sub>CC</sub> is pulled down below 5V.

**5.3 Overload Protection (OLP):** Overload is defined as the load current exceeding its normal level due to an unexpected abnormal event. In this situation, the protection circuit should trigger to protect the power supply. However, even when the power supply is in the normal condition, the overload situation can occur during the load transition. To avoid premature triggering of protection, the overload protection circuit should be designed to trigger only after a specified time to determine whether it is a transient situation or a true overload situation. Figure 27 shows a typical overload protection circuit. By sensing the resonant capacitor voltage on the control pin, the overload protection can be implemented. Using RC time constant, shutdown delay can be also introduced. The voltage obtained on the control pin is given as:

$$V_{CON} = \frac{C_B}{2(C_B + C_{sense})} V_{Cr}^{p-p} \quad (7)$$

where  $V_{Cr}^{p-p}$  is the amplitude of the resonant capacitor voltage.

**5.4 Over-Voltage Protection: (OVP):** When the LV<sub>CC</sub> reaches 23V, OVP is triggered. This protection is used when auxiliary winding of the transformer to supply V<sub>CC</sub> to the controller is utilized.

**5.5 Thermal Shutdown (TSD):** If the temperature of the junction exceeds approximately 130°C, the thermal shutdown triggers.

**6. PCB Layout Guideline:** Duty imbalance problems may occur due to the radiated noise from main transformer, the inequality of the secondary-side leakage inductances of main transformer, and so on. Among them, it is one of the dominant reasons that the control components in the vicinity of  $R_T$  pin are enclosed by the primary current flow pattern on PCB layout. The direction of the magnetic field on the components caused by the primary current flow is changed when the high-and-low side MOSFET turns on by turns. The magnetic fields with opposite direction from each other induce a current through, into, or out of the  $R_T$  pin, which makes the turn-on duration of each MOSFET different. It is strongly recommended to separate the control components in the vicinity of  $R_T$  pin from the primary current flow pattern on PCB layout. Figure 28 shows an example for the duty-balanced case. The yellow and blue lines show the primary current flows when the lower-side and higher-side MOSFETs turns on, respectively. The primary current does not enclose any component of controller.

In addition, it is helpful to reduce the duty imbalance to make the loop configured between CON pin and optocoupler as small as possible, as shown in the red line in Figure 28.

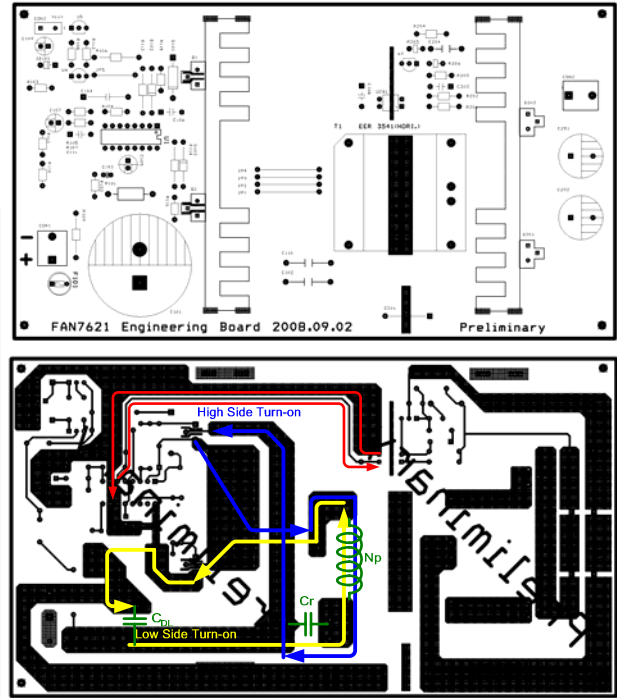


Figure 28. Example for Duty Balancing

### Typical Application Circuit (Half-Bridge LLC Resonant Converter)

Application	Device	Input Voltage Range	Rated Output Power	Output Voltage (Rated Current)
LCD TV	FAN7621B	390V <sub>DC</sub> (340~400V <sub>DC</sub> )	192W	24V-8A

#### Features

- High efficiency (>94% at 400V<sub>DC</sub> input)
- Reduced EMI noise through zero-voltage-switching (ZVS)
- Enhanced system reliability with various protection functions

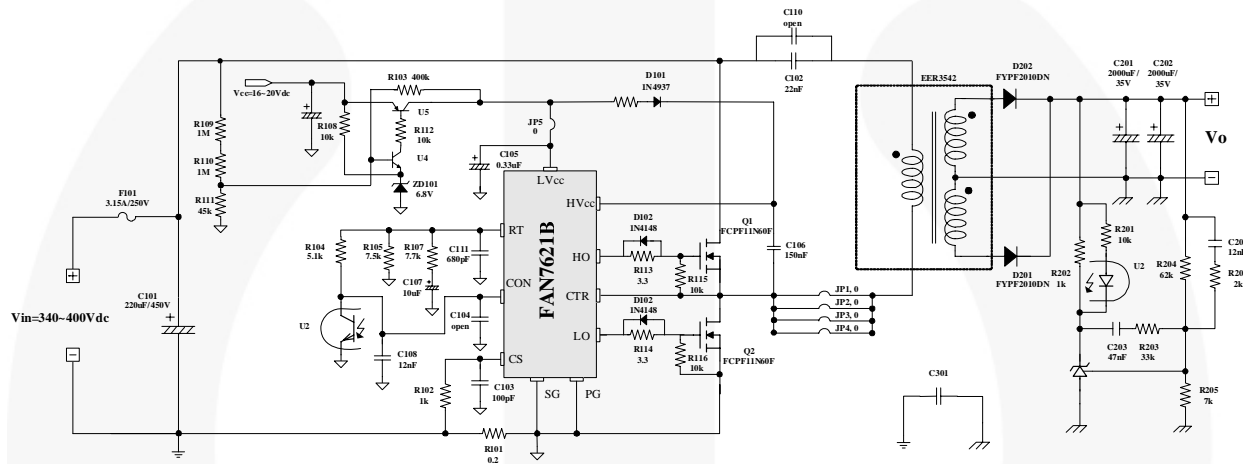


Figure 29. Typical Application Circuit

### Typical Application Circuit (Continued)

Usually, LLC resonant converters require large leakage inductance value. To obtain a large leakage inductance, sectional winding method is used.

- Core: EC35 ( $A_e=106 \text{ mm}^2$ )
- Bobbin: EC35 (Horizontal)
- Transformer Model Number: SNX-2468-1

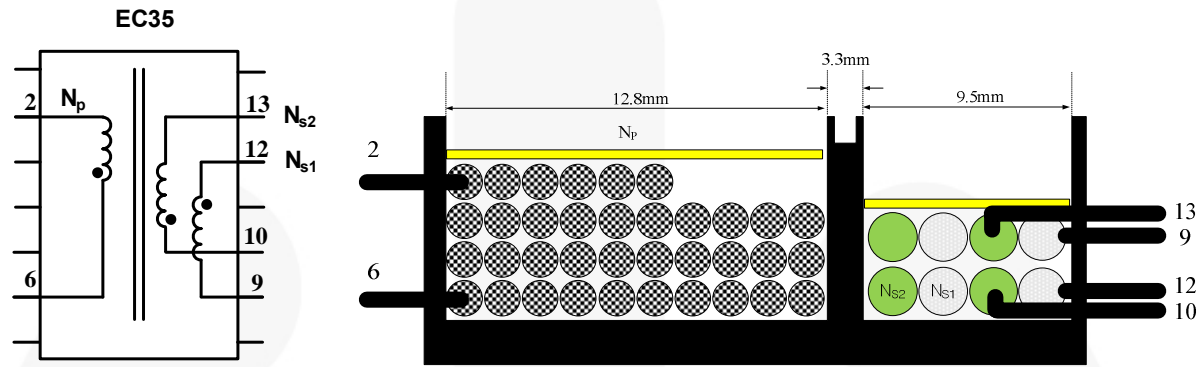


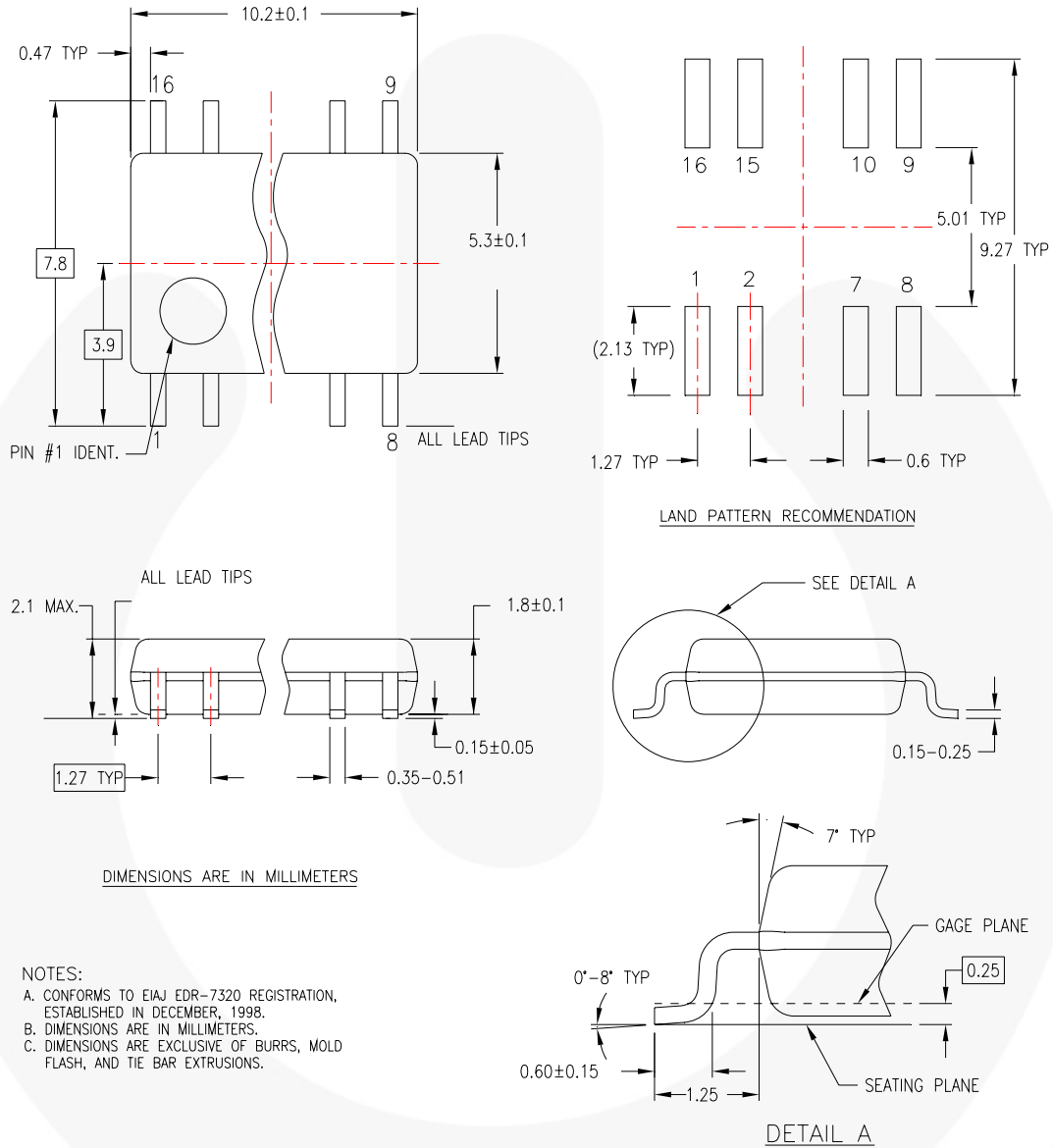
Figure 30. Transformer Construction

	Pins (S → F)	Wire	Turns	Note
$N_p$	6 → 2	0.08φ×88 (Litz Wire)	36	
$N_{s1}$	12 → 9	0.08φ×234 (Litz Wire)	4	Bifilar Winding
$N_{s2}$	10 → 13	0.08φ×234 (Litz Wire)	4	Bifilar Winding

	Pins	Specifications	Remark
Primary-Side Inductance ( $L_p$ )	2 – 6	550μH ± 10%	100kHz, 1V
Primary-Side Effective Leakage ( $L_r$ )	2 – 6	110μH ± 10%	Short one of the secondary windings

For more detailed information regarding the transformer, visit <http://www.santronics-usa.com/documents.html> or contact [sales@santronics-usa.com](mailto:sales@santronics-usa.com) or +1-408-734-1878 (Sunnyvale, California USA).

## Physical Dimensions



M16DREVC

**Figure 31. 16-Lead Small Outline Package (SOP)**

Package drawings are provided as a service to customers considering Fairchild components. Drawings may change in any manner without notice. Please note the revision and/or date on the drawing and contact a Fairchild Semiconductor representative to verify or obtain the most recent revision. Package specifications do not expand the terms of Fairchild's worldwide terms and conditions, specifically the warranty therein, which covers Fairchild products.

Always visit Fairchild Semiconductor's online packaging area for the most recent package drawings:  
<http://www.fairchildsemi.com/packaging/>.



**TRADEMARKS**

The following includes registered and unregistered trademarks and service marks, owned by Fairchild Semiconductor and/or its global subsidiaries, and is not intended to be an exhaustive list of all such trademarks.

- |                          |                        |                                       |   |
|--------------------------|------------------------|---------------------------------------|---|
| AccuPower™               | F-PFS™                 | Power-SPM™                            | <p><b>SYSTEM GENERAL</b><br/>The Power Franchise®<br/><b>the power franchise</b><br/>TinyBoost™<br/>TinyBuck™<br/>TinyCalc™<br/>TinyLogic®<br/>TINYOPTO™<br/>TinyPower™<br/>TinyPWM™<br/>TinyWire™<br/>TriFault Detect™<br/>TRUECURRENT™*<br/>µSerDes™<br/> SerDes™<br/>UHC®<br/>Ultra FRFET™<br/>UniFET™<br/>VCX™<br/>VisualMax™<br/>XS™</p> |
| Auto-SPM™                | FRFET®                 | PowerTrench®                          |   |
| Build it Now™            | Global Power Resource™ | PowerXS™                              |   |
| CorePLUS™                | Green FPS™             | Programmable Active Droop™            |   |
| CorePOWER™               | Green FPS™ e-Series™   | QFET®                                 |   |
| CROSSVOL™                | Gmax™                  | QST™                                  |   |
| CTL™                     | GTO™                   | Quiet Series™                         |   |
| Current Transfer Logic™  | IntelliMAX™            | RapidConfigure™                       |   |
| DEUXPEED®                | ISOPLANAR™             | Saving our world, 1mW/W/kW at a time™ |   |
| Dual Cool™               | MegaBuck™              | SignalWise™                           |   |
| EcoSPARK®                | MICROCOUPLER™          | SmartMax™                             |   |
| EfficientMax™            | MicroFET™              | SMART START™                          |   |
| ESBC™                    | MicroPak™              | SPM®                                  |   |
| Fairchild®               | MicroPak2™             | STEALTH™                              |   |
| Fairchild Semiconductor® | MillerDrive™           | SuperFET™                             |   |
| FACT Quiet Series™       | MotionMax™             | SuperSOT™-3                           |   |
| FACT®                    | Motion-SPM™            | SuperSOT™-6                           |   |
| FAST®                    | OptoHIT™               | SuperSOT™-8                           |   |
| FastvCore™               | OPTOLOGIC®             | SupreMOS®                             |   |
| FETBench™                | OPTOPLANAR®            | SyncFET™                              |   |
| FlashWriter®             |                        | Sync-Lock™                            |   |
| FPS™                     | PDP SPM™               |                                       |   |

\* Trademarks of System General Corporation, used under license by Fairchild Semiconductor.

**DISCLAIMER**

FAIRCHILD SEMICONDUCTOR RESERVES THE RIGHT TO MAKE CHANGES WITHOUT FURTHER NOTICE TO ANY PRODUCTS HEREIN TO IMPROVE RELIABILITY, FUNCTION, OR DESIGN. FAIRCHILD DOES NOT ASSUME ANY LIABILITY ARISING OUT OF THE APPLICATION OR USE OF ANY PRODUCT OR CIRCUIT DESCRIBED HEREIN; NEITHER DOES IT CONVEY ANY LICENSE UNDER ITS PATENT RIGHTS, NOR THE RIGHTS OF OTHERS. THESE SPECIFICATIONS DO NOT EXPAND THE TERMS OF FAIRCHILD'S WORLDWIDE TERMS AND CONDITIONS, SPECIFICALLY THE WARRANTY THEREIN, WHICH COVERS THESE PRODUCTS.

**LIFE SUPPORT POLICY**

FAIRCHILD'S PRODUCTS ARE NOT AUTHORIZED FOR USE AS CRITICAL COMPONENTS IN LIFE SUPPORT DEVICES OR SYSTEMS WITHOUT THE EXPRESS WRITTEN APPROVAL OF FAIRCHILD SEMICONDUCTOR CORPORATION.

As used herein:

1. Life support devices or systems are devices or systems which, (a) are intended for surgical implant into the body or (b) support or sustain life, and (c) whose failure to perform when properly used in accordance with instructions for use provided in the labeling, can be reasonably expected to result in a significant injury of the user.
2. A critical component in any component of a life support, device, or system whose failure to perform can be reasonably expected to cause the failure of the life support device or system, or to affect its safety or effectiveness.

**ANTI-COUNTERFEITING POLICY**

Fairchild Semiconductor Corporation's Anti-Counterfeiting Policy. Fairchild's Anti-Counterfeiting Policy is also stated on our external website, [www.fairchildsemi.com](http://www.fairchildsemi.com), under Sales Support.

Counterfeiting of semiconductor parts is a growing problem in the industry. All manufacturers of semiconductor products are experiencing counterfeiting of their parts. Customers who inadvertently purchase counterfeit parts experience many problems such as loss of brand reputation, substandard performance, failed applications, and increased cost of production and manufacturing delays. Fairchild is taking strong measures to protect ourselves and our customers from the proliferation of counterfeit parts. Fairchild strongly encourages customers to purchase Fairchild parts either directly from Fairchild or from Authorized Fairchild Distributors who are listed by country on our web page cited above. Products customers buy either from Fairchild directly or from Authorized Fairchild Distributors are genuine parts, have full traceability, meet Fairchild's quality standards for handling and storage and provide access to Fairchild's full range of up-to-date technical and product information. Fairchild and our Authorized Distributors will stand behind all warranties and will appropriately address any warranty issues that may arise. Fairchild will not provide any warranty coverage or other assistance for parts bought from Unauthorized Sources. Fairchild is committed to combat this global problem and encourage our customers to do their part in stopping this practice by buying direct or from authorized distributors.

**PRODUCT STATUS DEFINITIONS**

**Definition of Terms**

Datasheet Identification	Product Status	Definition
Advance Information	Formative / In Design	Datasheet contains the design specifications for product development. Specifications may change in any manner without notice.
Preliminary	First Production	Datasheet contains preliminary data; supplementary data will be published at a later date. Fairchild Semiconductor reserves the right to make changes at any time without notice to improve design.
No Identification Needed	Full Production	Datasheet contains final specifications. Fairchild Semiconductor reserves the right to make changes at any time without notice to improve the design.
Obsolete	Not In Production	Datasheet contains specifications on a product that is discontinued by Fairchild Semiconductor. The datasheet is for reference information only.

Rev. 149

# AMEYA360

## Components Supply Platform

Authorized Distribution Brand :



Website :

Welcome to visit [www.ameya360.com](http://www.ameya360.com)

Contact Us :

➤ Address :

401 Building No.5, JiuGe Business Center, Lane 2301, Yishan Rd  
Minhang District, Shanghai , China

➤ Sales :

Direct +86 (21) 6401-6692

Email [amall@ameya360.com](mailto:amall@ameya360.com)

QQ 800077892

Skype [ameyasales1](#) [ameyasales2](#)

➤ Customer Service :

Email [service@ameya360.com](mailto:service@ameya360.com)

➤ Partnership :

Tel +86 (21) 64016692-8333

Email [mkt@ameya360.com](mailto:mkt@ameya360.com)