



ON Semiconductor®

<http://onsemi.com>

LB1938FA

Monolithic Digital IC

1ch, Low-saturation Forward/Reverse Motor Driver

Overview

The LB1938FA is an H-bridge motor driver that supports low-voltage drive and features low-saturation outputs in an ultraminiature slim package. The LB1938FA provides forward, reverse, brake, and standby modes controlled by two input signals, and is an optimal DC motor driver for notebook personal computers, digital cameras, cell phones, and other portable equipment.

Features

- Ultraminiature Micro8 package
- The low saturation voltage means that the voltage applied to the motor is higher and IC heat generation is reduced. This allows this IC to be used in environments with higher ambient operating temperatures. Output saturation voltage (high side + low side): $V_{O\text{sat}} = 0.15\text{V}$ typical ($I_O = 100\text{mA}$)
- The wide usable voltage range and the low standby mode current drain of $0.1\ \mu\text{A}$ make this IC optimal for battery operated equipment.
- There are no constraints on the relationship between the input signal voltage and the supply voltage. For example, this IC can be use at $V_{CC} = 3\text{V}$ and $V_{IN} = 5\text{V}$.
- Thermal protection circuit limits the drive current and prevents the IC from causing a fire or being destroyed if the IC chip temperature reaches or exceeds 180°C due to large currents flowing when the outputs are shorted due to, for example, motor layer shorting or other phenomena.

Specifications

Absolute Maximum Ratings at $T_a = 25^\circ\text{C}$

Parameter	Symbol	Conditions	Ratings	Unit
Supply voltage	V_{CC} max		10.5	V
Output current	I_{OUT} max		800	mA
Output voltage	V_{OUT} max		$V_{CC} + V_{SF}$	V
Input applied voltage	V_{IH} max		10	V
Allowable power dissipation	P_d max	Mounted on a specified board *	400	mW
Operating temperature range	T_{opr}		-30 to +85	$^\circ\text{C}$
Storage temperature range	T_{stg}		-55 to +150	$^\circ\text{C}$

Note *: Mounted on a specified board: 114.3mm×76.1mm×1.5mm, glass epoxy resin, wiring density 20%

Caution 1) Absolute maximum ratings represent the value which cannot be exceeded for any length of time.

Caution 2) Even when the device is used within the range of absolute maximum ratings, as a result of continuous usage under high temperature, high current, high voltage, or drastic temperature change, the reliability of the IC may be degraded. Please contact us for the further details.

Stresses exceeding Maximum Ratings may damage the device. Maximum Ratings are stress ratings only. Functional operation above the Recommended Operating Conditions is not implied. Extended exposure to stresses above the Recommended Operating Conditions may affect device reliability.

LB1938FA

Allowable Operating Range at $T_a = 25^\circ\text{C}$

Parameter	Symbol	Conditions	Ratings	Unit
Supply voltage	V_{CC}		2.2 to 10	V
Input high-level voltage	V_{IH}		2.0 to 9.5	V
Input low-level voltage	V_{IL}		-0.3 to +0.3	V

Electrical Characteristics at $T_a = 25^\circ\text{C}$, $V_{CC} = 3\text{V}$

Parameter	Symbol	Conditions	Ratings			Unit
			min	typ	max	
Circuit current	I_{CC1}	Standby		0.1	5	μA
	I_{CC2}	Forward/reverse drive		14	19	mA
	I_{CC3}	Brake		20	29	mA
Output saturation voltage	V_{Osat1}	Upper+lower $I_O = 100\text{mA}$ for forward/reverse rotation		0.15	0.2	V
	V_{Osat2}	Upper+lower $I_O = 300\text{mA}$ for forward/reverse rotation		0.35	0.5	V
	V_{Osat3}	Upper $I_O = 100\text{mA}$ for braking		0.1	0.15	V
Spark killer diode forward voltage	V_{SF}	$I_O = 300\text{mA}$		0.9	1.7	V
Spark killer diode inverse current	I_{RS}	$V_{OUT} = 10\text{V}$		0.1	5	μA
Input current	I_{IN}	$V_{IN} = 5\text{V}$		75	98	μA
Thermal protection operating temperature	TSD	Design target value *		180		$^\circ\text{C}$

Note *: Design target value: Measurement with a single unit not made.

Package Dimensions

unit : mm (typ)

3427

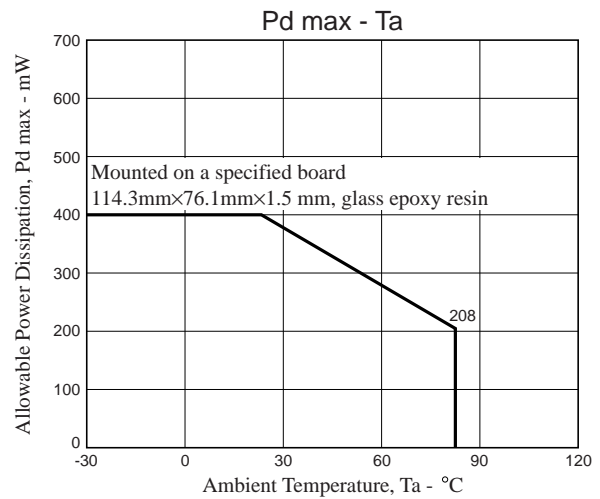
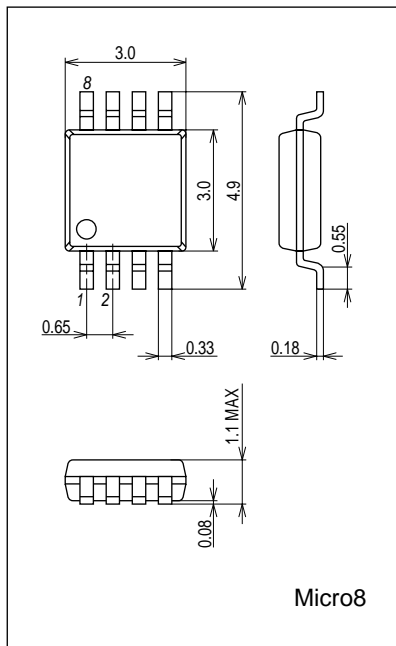

LB1938FA

Pin Assignment

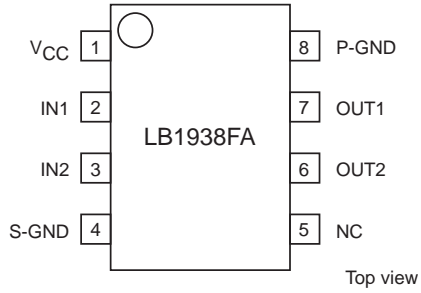

S-GND: GND for the control system

P-GND: GND for the power system

Truth Table

IN1	IN2	OUT1	OUT2	Mode
L	L	OFF	OFF	Standby
H	L	H	L	Forward rotation
L	H	L	H	Reverse rotation
H	H	H	H	Brake

Sample Application Circuit

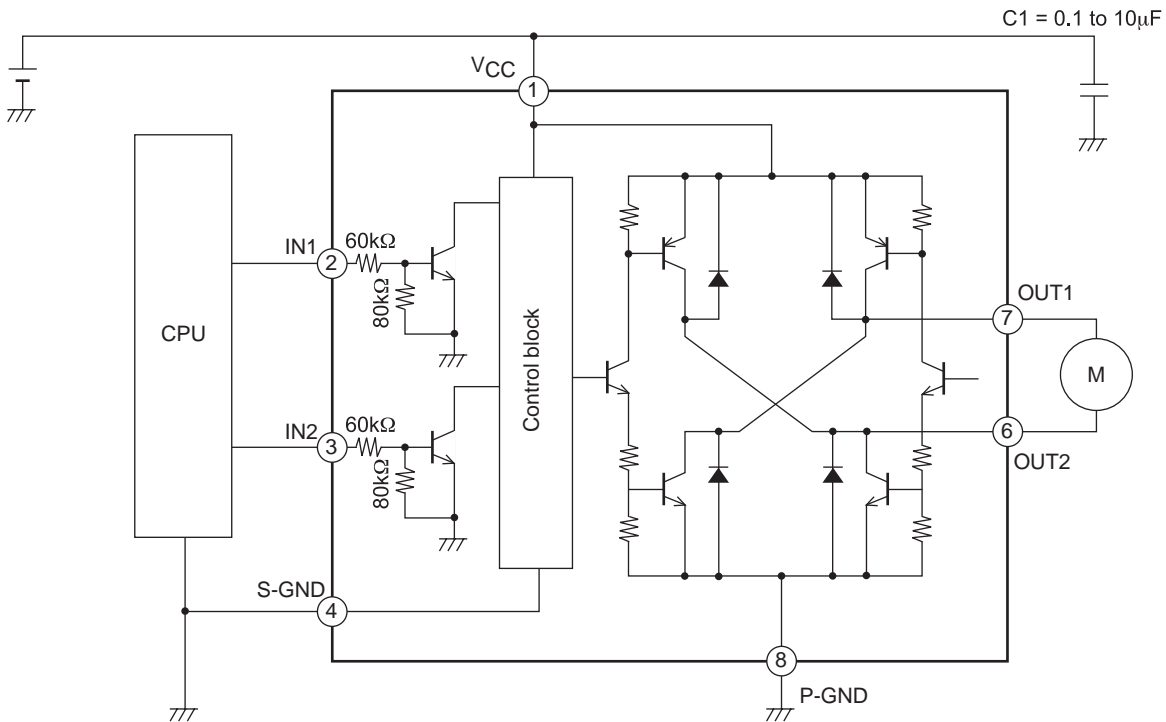

Cautions:

- VCC and GND lines suffer substantial fluctuation in the current quantity, causing a problem of line oscillation in certain cases. In this case, take following points into account:
 - (1) Use a thick and short wiring to reduce the wiring inductance.
 - (2) Insert a capacitor with satisfactory frequency characteristics near IC.
 - (3) Connect S-GND to the control system GND on the CPU side and P-GND to the power system GND.

LB1938FA

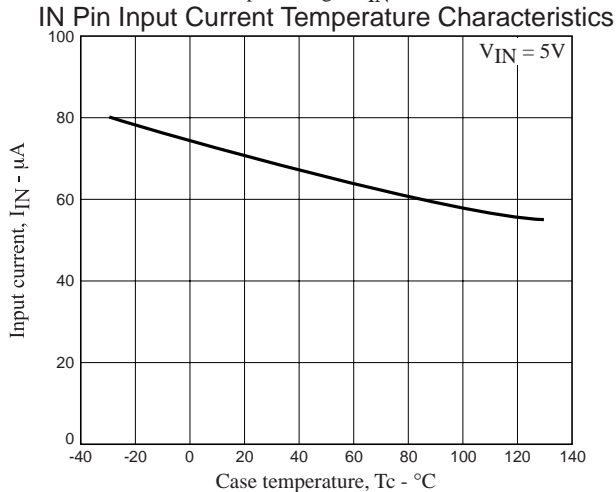
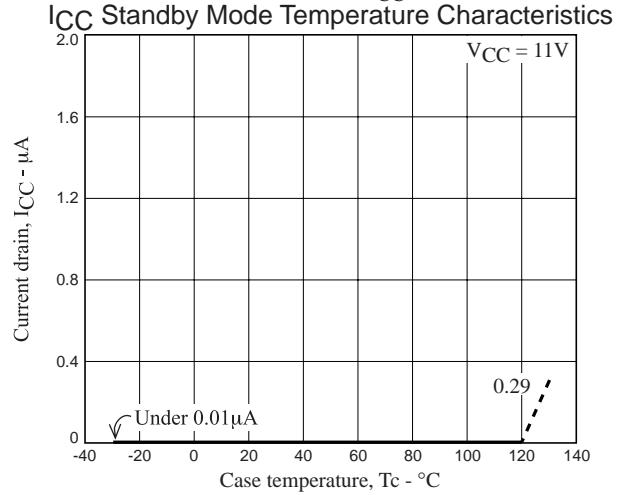
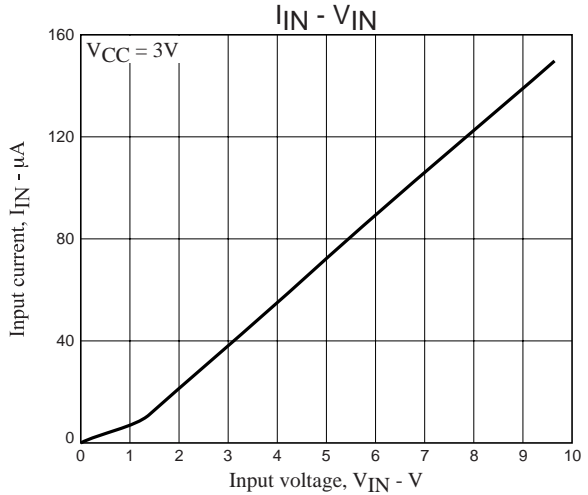
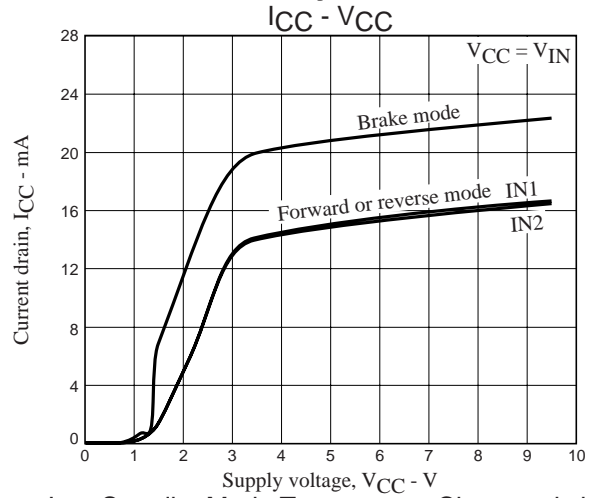
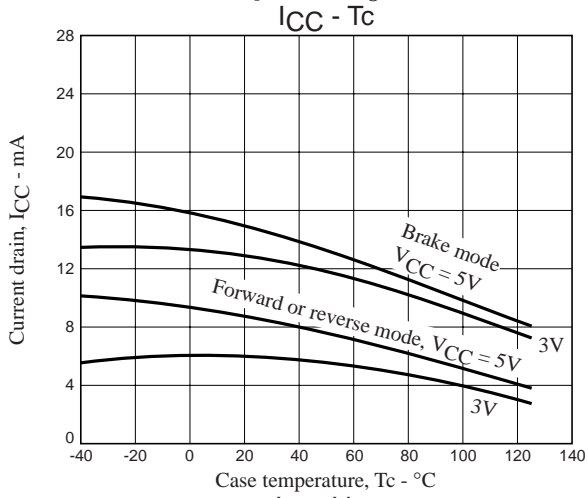
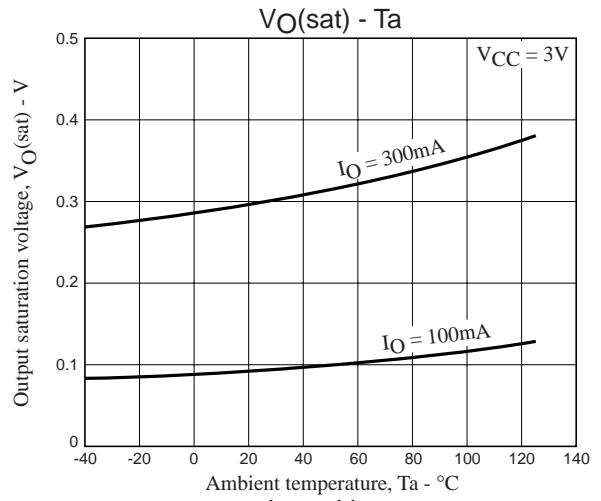
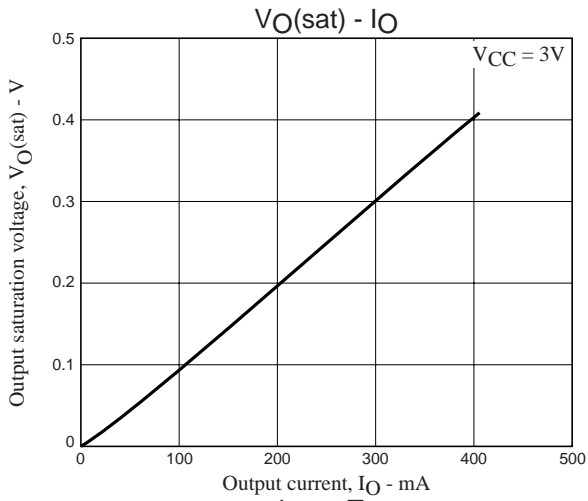

ON Semiconductor and the ON logo are registered trademarks of Semiconductor Components Industries, LLC (SCILLC). SCILLC owns the rights to a number of patents, trademarks, copyrights, trade secrets, and other intellectual property. A listing of SCILLC's product/patent coverage may be accessed at www.onsemi.com/site/pdf/Patent-Marking.pdf. SCILLC reserves the right to make changes without further notice to any products herein. SCILLC makes no warranty, representation or guarantee regarding the suitability of its products for any particular purpose, nor does SCILLC assume any liability arising out of the application or use of any product or circuit, and specifically disclaims any and all liability, including without limitation special, consequential or incidental damages. "Typical" parameters which may be provided in SCILLC data sheets and/or specifications can and do vary in different applications and actual performance may vary over time. All operating parameters, including "Typicals" must be validated for each customer application by customer's technical experts. SCILLC does not convey any license under its patent rights nor the rights of others. SCILLC products are not designed, intended, or authorized for use as components in systems intended for surgical implant into the body, or other applications intended to support or sustain life, or for any other application in which the failure of the SCILLC product could create a situation where personal injury or death may occur. Should Buyer purchase or use SCILLC products for any such unintended or unauthorized application, Buyer shall indemnify and hold SCILLC and its officers, employees, subsidiaries, affiliates, and distributors harmless against all claims, costs, damages, and expenses, and reasonable attorney fees arising out of, directly or indirectly, any claim of personal injury or death associated with such unintended or unauthorized use, even if such claim alleges that SCILLC was negligent regarding the design or manufacture of the part. SCILLC is an Equal Opportunity/Affirmative Action Employer. This literature is subject to all applicable copyright laws and is not for resale in any manner.

AMEYA360

Components Supply Platform

Authorized Distribution Brand :



Website :

Welcome to visit www.ameya360.com

Contact Us :

➤ Address :

401 Building No.5, JiuGe Business Center, Lane 2301, Yishan Rd
Minhang District, Shanghai , China

➤ Sales :

Direct +86 (21) 6401-6692

Email amall@ameya360.com

QQ 800077892

Skype [ameyasales1](#) [ameyasales2](#)

➤ Customer Service :

Email service@ameya360.com

➤ Partnership :

Tel +86 (21) 64016692-8333

Email mkt@ameya360.com