

150 mA low noise and high PSRR linear voltage regulator

Datasheet - production data

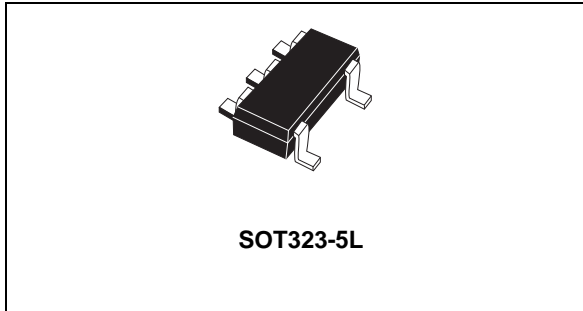

- Package: SOT323-5L
- Temperature range: -40 °C to 125 °C

Description

The LD59015 provides 150 mA maximum current with an input voltage range from 2.4 V to 5.5 V, and a typical dropout voltage of 150 mV. It is stable with ceramic capacitors. High PSRR, low quiescent current and low noise features make it suitable for low power battery-powered applications. Power supply rejection is 80 dB at low frequency and starts to roll off at 10 kHz. The enable logic control function puts the LD59015 in shutdown mode, allowing a total current consumption lower than 1 µA. The device also includes short-circuit constant current limiting and thermal protection. Typical applications are mobile phones, personal digital assistants (PDAs), cordless phones and similar battery-powered systems.

Features

- Input voltage from 2.4 to 5.5 V
- Very low quiescent current (31 µA typ. at no load, 75 µA typ. at 150 mA load, 1 µA max. in OFF mode)
- Very low noise (20 µV_{RMS} at V_{OUT} = 1.5 V)
- Output voltage tolerance: ± 1.8% at 25 °C
- 150 mA guaranteed output current
- Wide range of output voltages available on request: 0.8 V to 3.3 V in 100 mV steps
- Logic-controlled electronic shutdown
- Compatible with ceramic capacitors
- Very high PSRR (80 dB @ 100 Hz, 76 @ 10 kHz, 54 @ 100 kHz)
- Internal current and thermal limit

Table 1. Device summary

Order codes	Output voltages
LD59015C08R	0.8 V
LD59015C12R	1.2 V
LD59015C15R	1.5 V
LD59015C18R	1.8 V
LD59015C25R	2.5 V
LD59015C30R	3.0 V
LD59015C33R	3.3 V

Contents

1	Block diagram	3
2	Pin configuration	4
3	Typical application	5
4	Maximum ratings	6
5	Electrical characteristics	7
6	Typical performance characteristics	9
7	Package mechanical data	12
8	Packaging mechanical data	14
9	Revision history	16

1 Block diagram

Figure 1. LD59015 block diagram

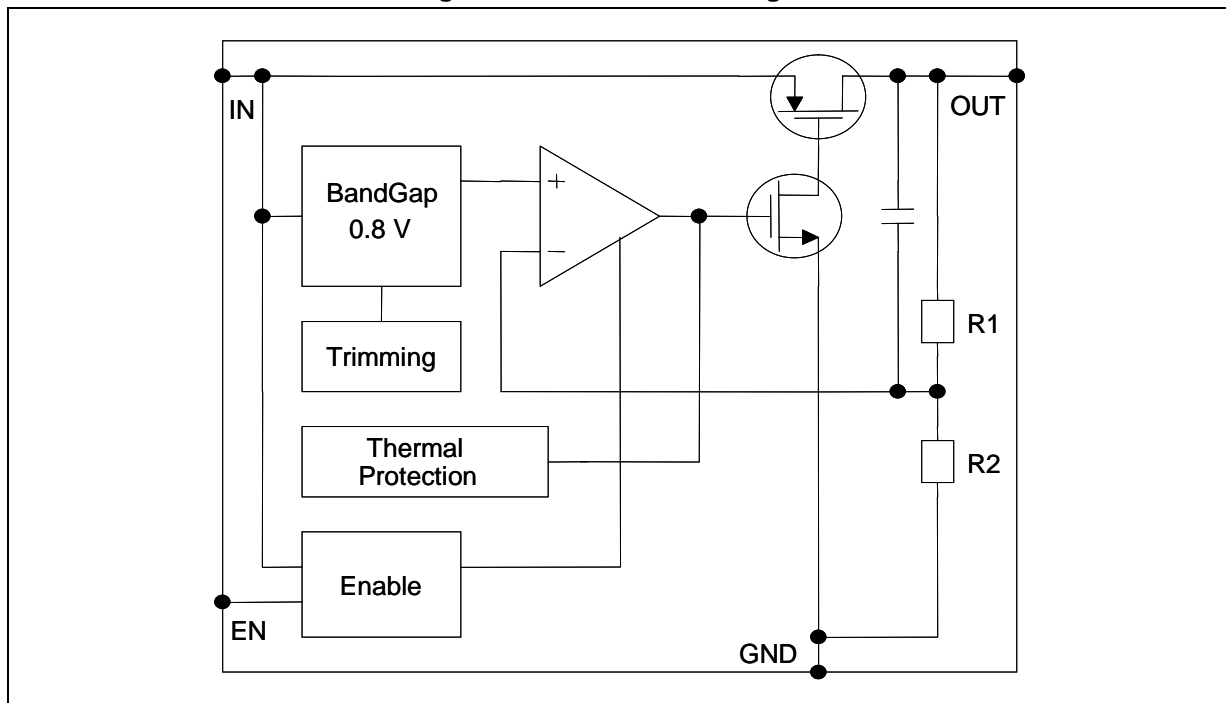

2 Pin configuration

Figure 2. Pin connection (top view)

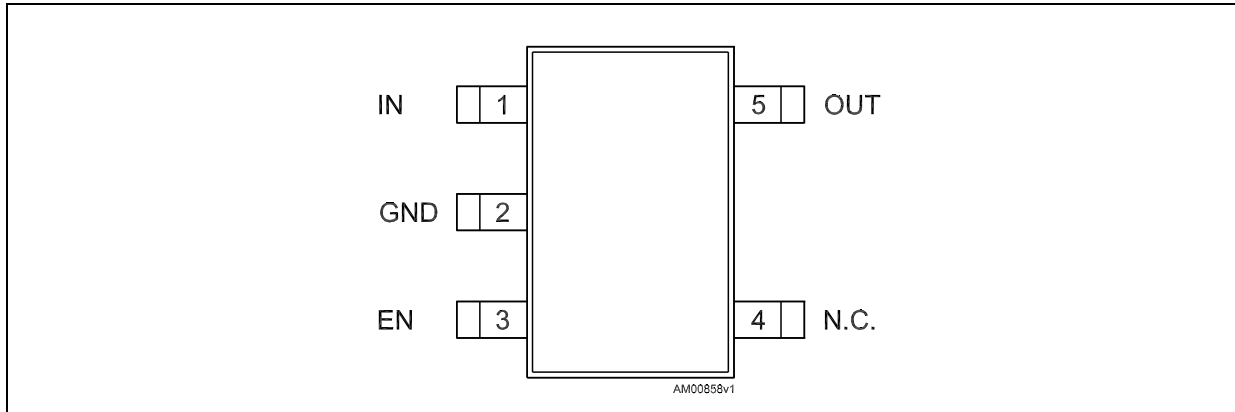
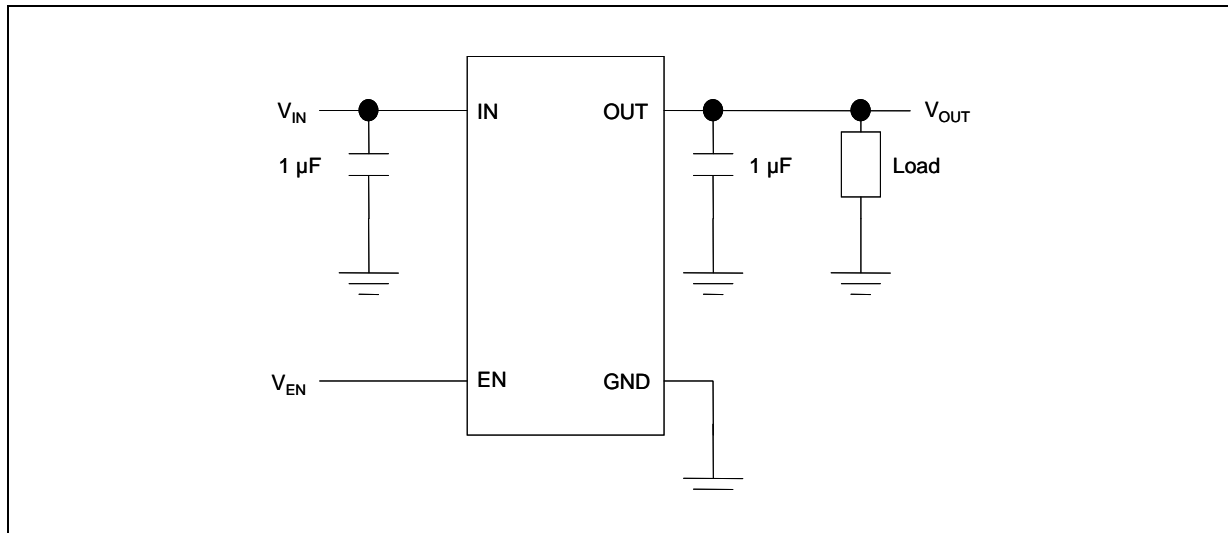

Table 2. Pin description

Pin n°	Symbol	Function
1	IN	Input voltage
2	GND	Ground
3	EN	Enable input Set $V_{EN} > 0.9$ to turn on the device Set $V_{EN} < 0.4$ to turn off the device
4	N.C.	Not connected
5	OUT	Output voltage

3 Typical application

Figure 3. Typical application circuit



4 Maximum ratings

Table 3. Absolute maximum ratings

Symbol	Parameter	Value	Unit
V_{IN}	DC input voltage	- 0.3 to 7	V
V_{OUT}	DC output voltage	- 0.3 to $V_I + 0.3$ (max. 7)	V
V_{EN}	Enable input voltage	- 0.3 to $V_I + 0.3$ (max. 7)	V
I_{OUT}	Output current	Internally limited	mA
P_D	Power dissipation	Internally limited	mW
ESD	Human body model	± 3	kV
	Machine model	± 300	V
T_{STG}	Storage temperature range	-65 to 150	°C
T_{OP}	Operating junction temperature range	-40 to 125	°C

Note: Absolute maximum ratings are those values beyond which damage to the device may occur. Functional operation under these conditions is not implied. All values are referred to GND.

Table 4. Thermal data

Symbol	Parameter	Value	Unit
R_{thJA}	Thermal resistance junction-ambient	645.69	°C/W
R_{thJC}	Thermal resistance junction-case	116	°C/W

5 Electrical characteristics

$T_J = 25\text{ °C}$, $V_{IN} = V_{OUT(NOM)} + 1\text{ V}$, $C_{IN} = C_{OUT} = 1\text{ }\mu\text{F}$, $I_{OUT} = 1\text{ mA}$, $V_{EN} = V_{IN}$, unless otherwise specified.

Table 5. Electrical characteristics (1)

Symbol	Parameter	Test conditions	Min.	Typ.	Max.	Unit
V_{IN}	Operating input voltage		2.4		5.5	V
V_{UVLO}	Turn-on threshold			2.0	2.15	
	Turn-off threshold		1.90	1.95		
V_{OUT}	V_{OUT} accuracy	$I_{OUT} = 1\text{ mA}$, $-40\text{ °C} < T_J < 125\text{ °C}$	-1.8		1.8	%
ΔV_{OUT}	Static line regulation	$V_{OUT} + 1\text{ V} \leq V_{IN} \leq 5.5\text{ V}$, $I_{OUT} = 1\text{ mA}$		0.001		%/V
ΔV_{OUT}	Static load regulation	$I_{OUT} = 1\text{ mA}$ to 150 mA		0.001		%/mA
V_{DROP}	Dropout voltage (2)	$I_{OUT} = 150\text{ mA}$, $V_{OUT} > 2.2\text{ V}$ $-40\text{ °C} < T_J < 125\text{ °C}$		150	210	mV
e_N	Output noise voltage	10Hz to 100kHz, $I_{OUT} = 10\text{ mA}$, $V_{OUT} = 1.5\text{ V}$		20		μV_{RMS} /V _{OUT}
SVR	Supply voltage rejection $V_{OUT} = 1.5\text{ V}$	$V_{IN} = V_{OUTNOM} + 1\text{ V} \pm V_{RIPPLE}$ $V_{RIPPLE} = 0.5\text{ V}$, frequency = 1kHz $I_{OUT} = 1\text{ mA}$		76		dB
		$V_{IN} = V_{OUTNOM} + 1\text{ V} \pm V_{RIPPLE}$ $V_{RIPPLE} = 0.5\text{ V}$, frequency = 10kHz $I_{OUT} = 1\text{ mA}$		76		
		$V_{IN} = V_{OUTNOM} + 1\text{ V} \pm V_{RIPPLE}$ $V_{RIPPLE} = 0.5\text{ V}$, frequency = 100kHz $I_{OUT} = 1\text{ mA}$		54		
I_Q	Quiescent current	$I_{OUT} = 0\text{ mA}$		31		μA
		$I_{OUT} = 0\text{ mA}$, $-40\text{ °C} < T_J < 125\text{ °C}$			60	
		$I_{OUT} = 0$ to 150 mA		75		
		$I_{OUT} = 0$ to 150 mA $-40\text{ °C} < T_J < 125\text{ °C}$			110	
		V_{IN} input current in OFF mode: $V_{EN} = \text{GND}$		0.001	1	
I_{SC}	Short-circuit current	$R_L = 0$	200			mA
V_{EN}	Enable input logic low	$V_{IN} = 2.4\text{ V}$ to 5.5 V , $-40\text{ °C} < T_J < 85\text{ °C}$			0.4	V
	Enable input logic high	$V_{IN} = 2.4\text{ V}$ to 5.5 V , $-40\text{ °C} < T_J < 85\text{ °C}$	0.9			V
I_{EN}	Enable pin input current	$V_{SHDN} = 5.5\text{ V}$		0.1	100	nA
T_{ON}	Turn-on time (3)			200		μs

Table 5. Electrical characteristics (continued) (1)

Symbol	Parameter	Test conditions	Min.	Typ.	Max.	Unit
T _{SHDN}	Thermal shutdown			160		°C
	Hysteresis			20		
C _{OUT}	Output capacitor	Capacitance (see typical performance characteristics for stability)	1		4.7	μF

1. For $V_{OUT(NOM)} < 1.3\text{ V}$, $V_{IN} = 2.4\text{ V}$.
2. Dropout voltage is the input-to-output voltage difference at which the output voltage is 100 mV below its nominal value. This specification does not apply to output voltages below 1.7 V.
3. Turn-on time is time measured between the enable input just exceeding V_{EN} high value and the output voltage just reaching 95% of its nominal value.

Note: All transient values are guaranteed by design, not tested in production.

6 Typical performance characteristics

$$C_{IN} = C_{OUT} = 1 \mu F$$

Figure 4. V_{OUT} vs. temperature ($V_{OUT} = 0.8 V$)

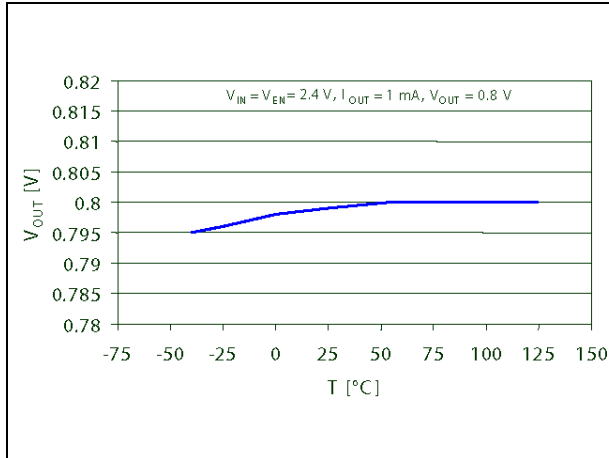

Figure 5. V_{OUT} vs. temperature ($V_{OUT} = 3.3 V$)

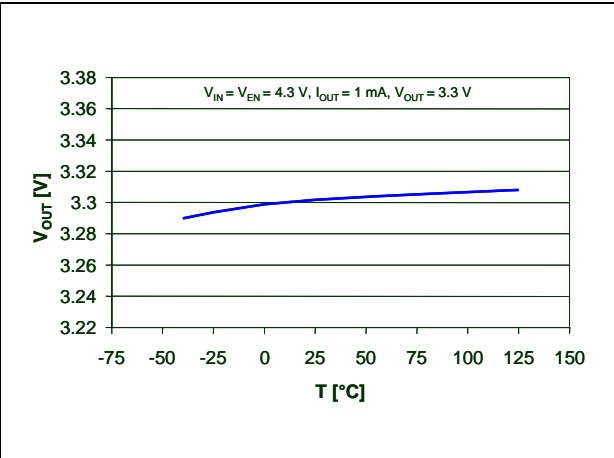

Figure 6. Quiescent current vs. temperature

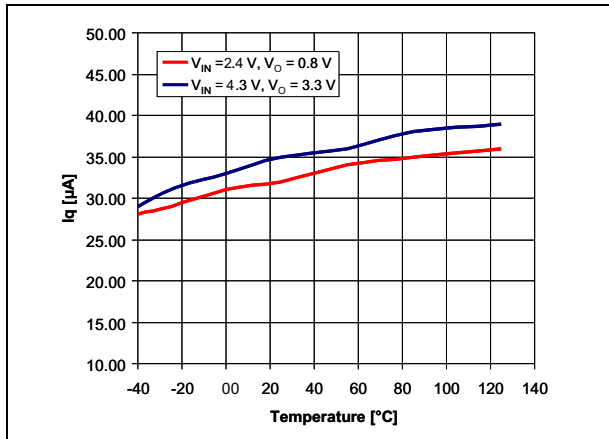

Figure 7. Quiescent current vs. I_{OUT}

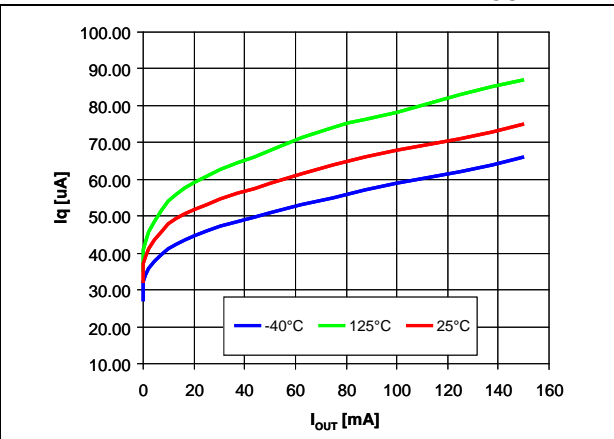

Figure 8. V_{OUT} vs. V_{IN}

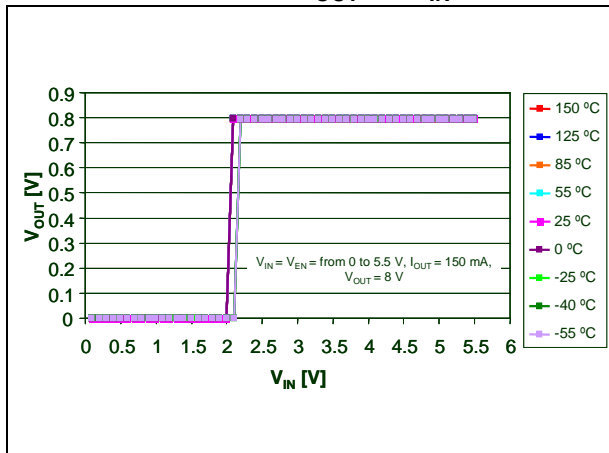

Figure 9. V_{DROP} vs. I_{OUT}

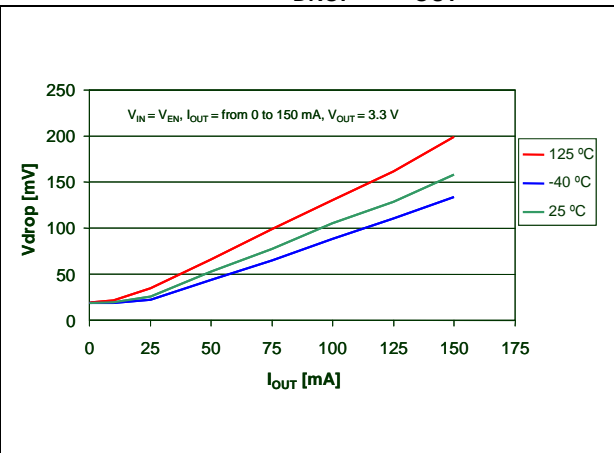

Figure 10. V_{UVLO} vs. temperature

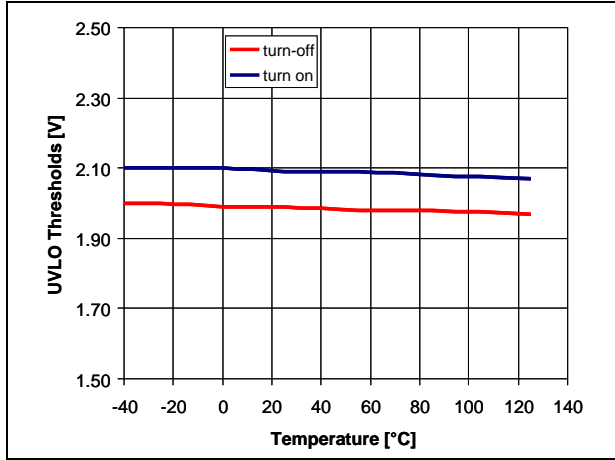

Figure 11. ESR vs. C_{OUT}

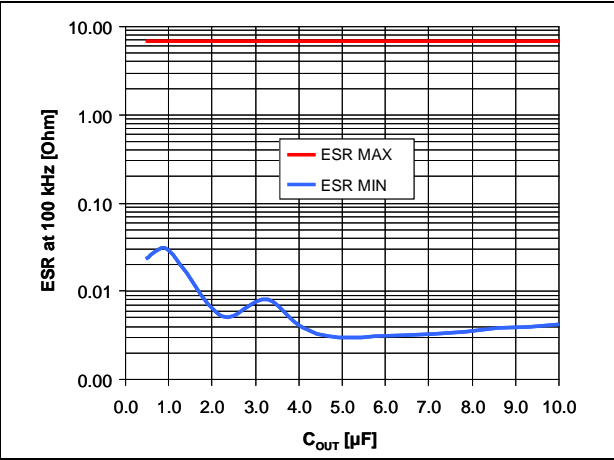

Figure 12. Supply voltage rejection vs. frequency

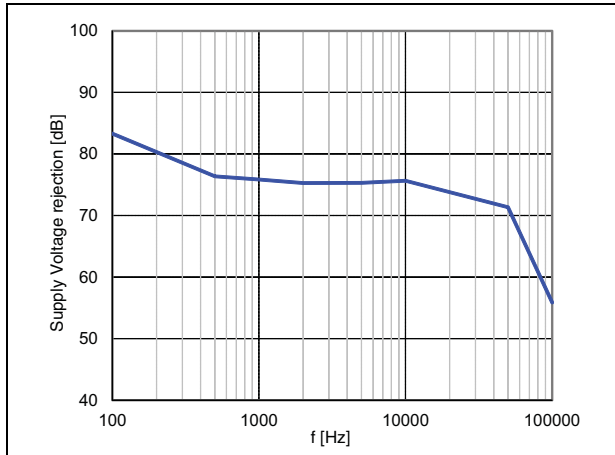

Figure 13. Supply voltage rejection vs. I_{OUT}

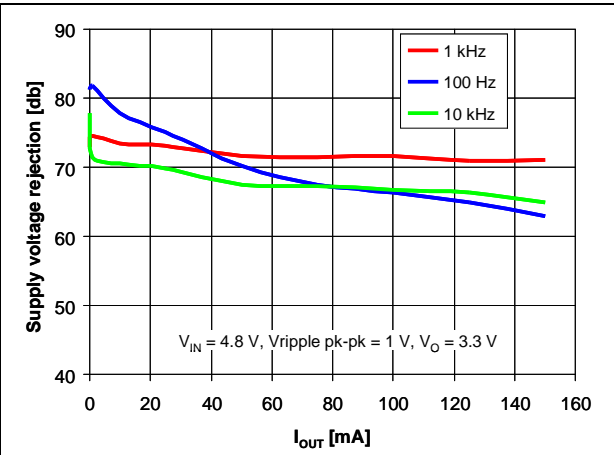

Figure 14. I_{SC} vs. V_{DROP}

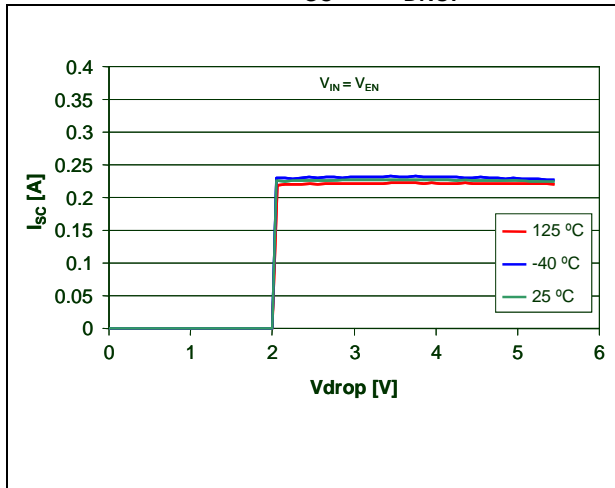

Figure 15. Line transient ($V_{OUT} = 0.8$ V)

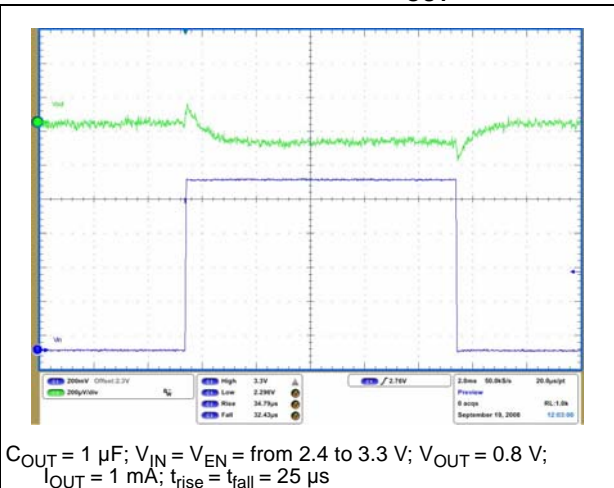
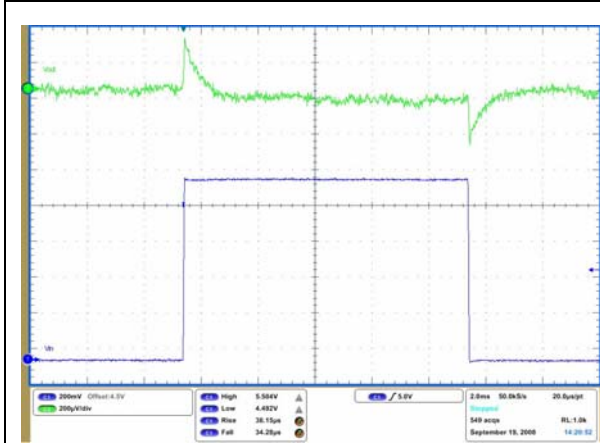
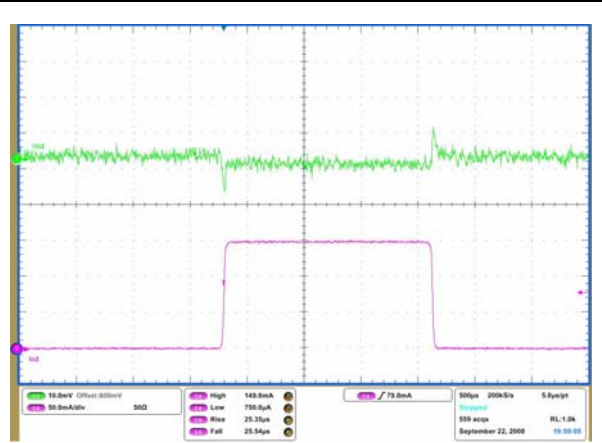

Figure 16. Line transient ($V_{OUT} = 3.3\text{ V}$)



$C_{OUT} = 1\ \mu\text{F}$; $V_{IN} = V_{EN} =$ from 4.5 to 5.5 V; $V_{OUT} = 3.3\text{ V}$;
 $I_{OUT} = 1\text{ mA}$; $t_{rise} = t_{fall} = 25\ \mu\text{s}$

Figure 17. Load transient ($V_{OUT} = 0.8\text{ V}$)



$C_{IN} = C_{OUT} = 1\ \mu\text{F}$; $V_{IN} = V_{EN} = 2.4\text{ V}$; $V_{OUT} = 0.8\text{ V}$;
 I_{OUT} from 0.1 to 150 mA; $t_{rise} = t_{fall} = 25\ \mu\text{s}$

Figure 18. Load transient ($V_{OUT} = 3.3\text{ V}$)

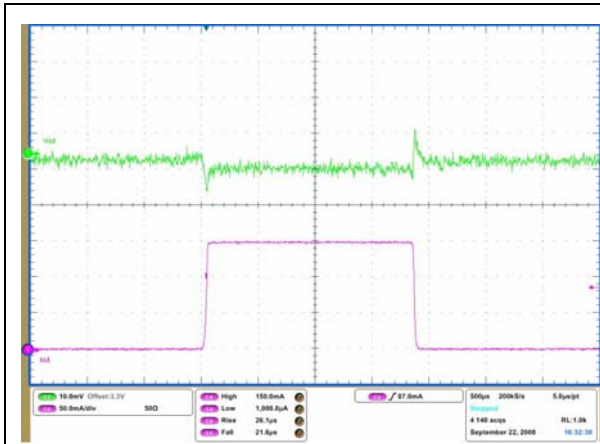

$C_{IN} = C_{OUT} = 1\ \mu\text{F}$; $V_{IN} = V_{EN} = 4.3\text{ V}$; $V_{OUT} = 3.3\text{ V}$;
 I_{OUT} from 0.1 to 150 mA; $t_{rise} = t_{fall} = 25\ \mu\text{s}$

Figure 19. Start-up transient

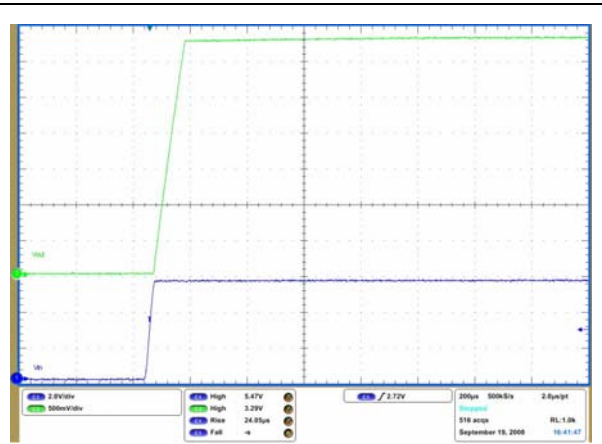

$C_{OUT} = 1\ \mu\text{F}$; $V_{IN} = V_{EN} =$ from 0 to 5.5 V; $V_{OUT} = 3.3\text{ V}$;
 $I_{OUT} = 150\text{ mA}$

Figure 20. Enable transient

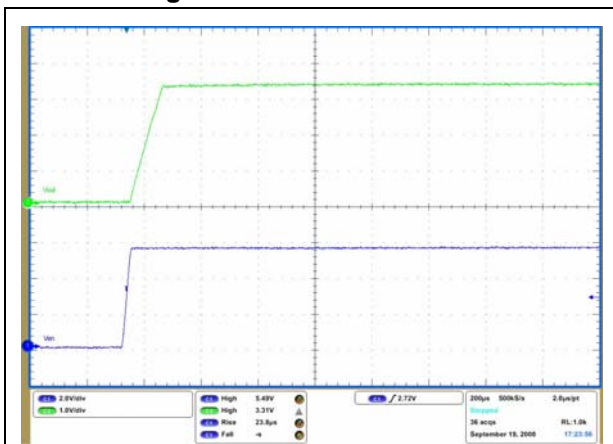

$C_{IN} = C_{OUT} = 1\ \mu\text{F}$; $V_{IN} = 4.3$; $V_{EN} =$ from 0 to 5.5 V;
 $V_{OUT} = 3.3\text{ V}$; $I_{OUT} = 1\text{ mA}$; $t_{rise} = 25\ \mu\text{s}$

7 Package mechanical data

In order to meet environmental requirements, ST offers these devices in different grades of ECOPACK® packages, depending on their level of environmental compliance. ECOPACK® specifications, grade definitions and product status are available at: www.st.com. ECOPACK® is an ST trademark.

Figure 21. SOT323-5L drawings

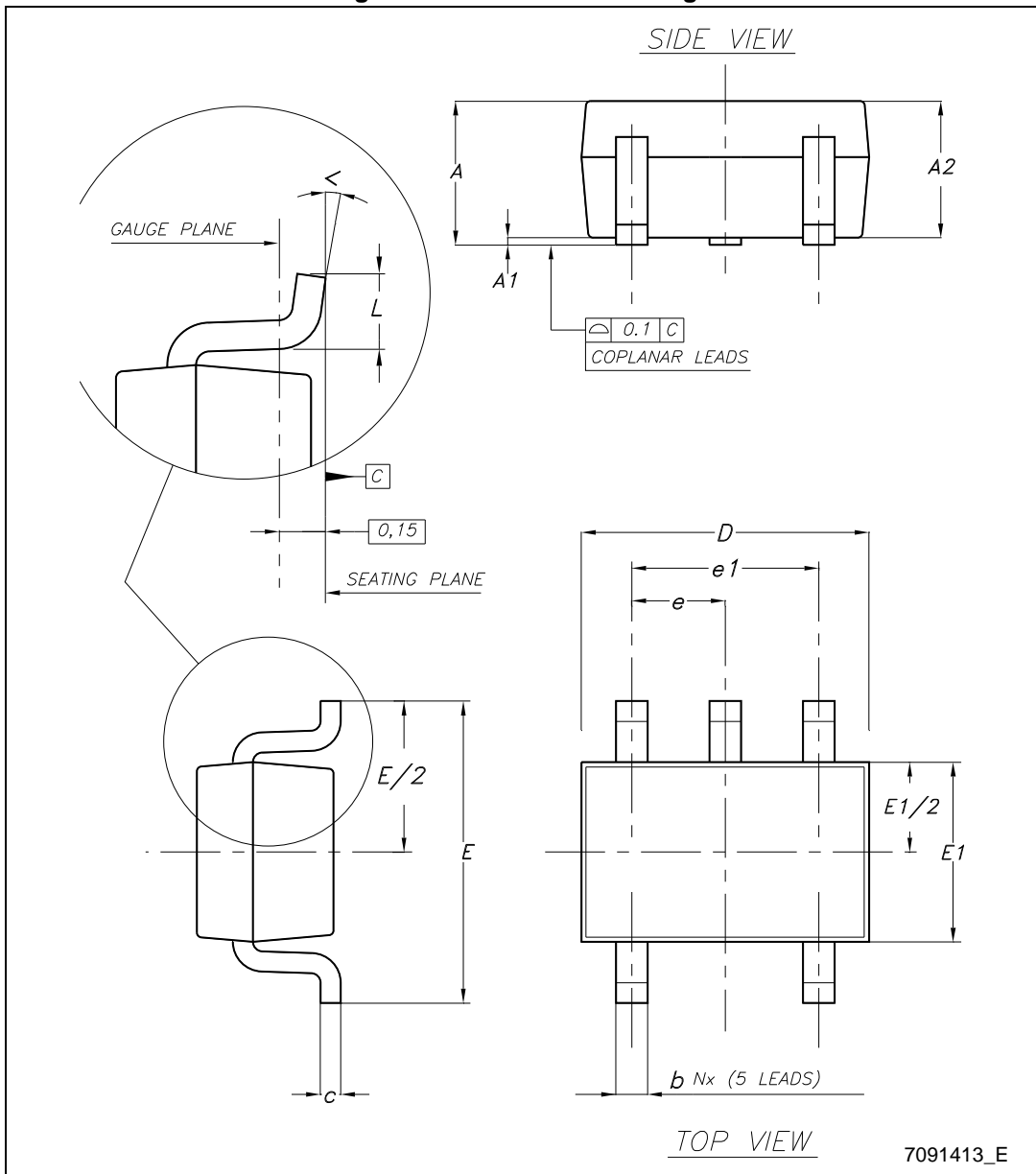

Table 6. SOT323-5L mechanical data

Dim.	mm		
	Min.	Typ.	Max.
A	0.80		1.10
A1	0		0.10
A2	0.80	0.90	1
b	0.15		0.30
c	0.10		0.22
D	1.80	2	2.20
E	1.80	2.10	2.40
E1	1.15	1.25	1.35
e		0.65	
e1		1.30	
L	0.26	0.36	0.46
<	0°		8°

8 Packaging mechanical data

Figure 22. SOT323-5L tape and reel drawings

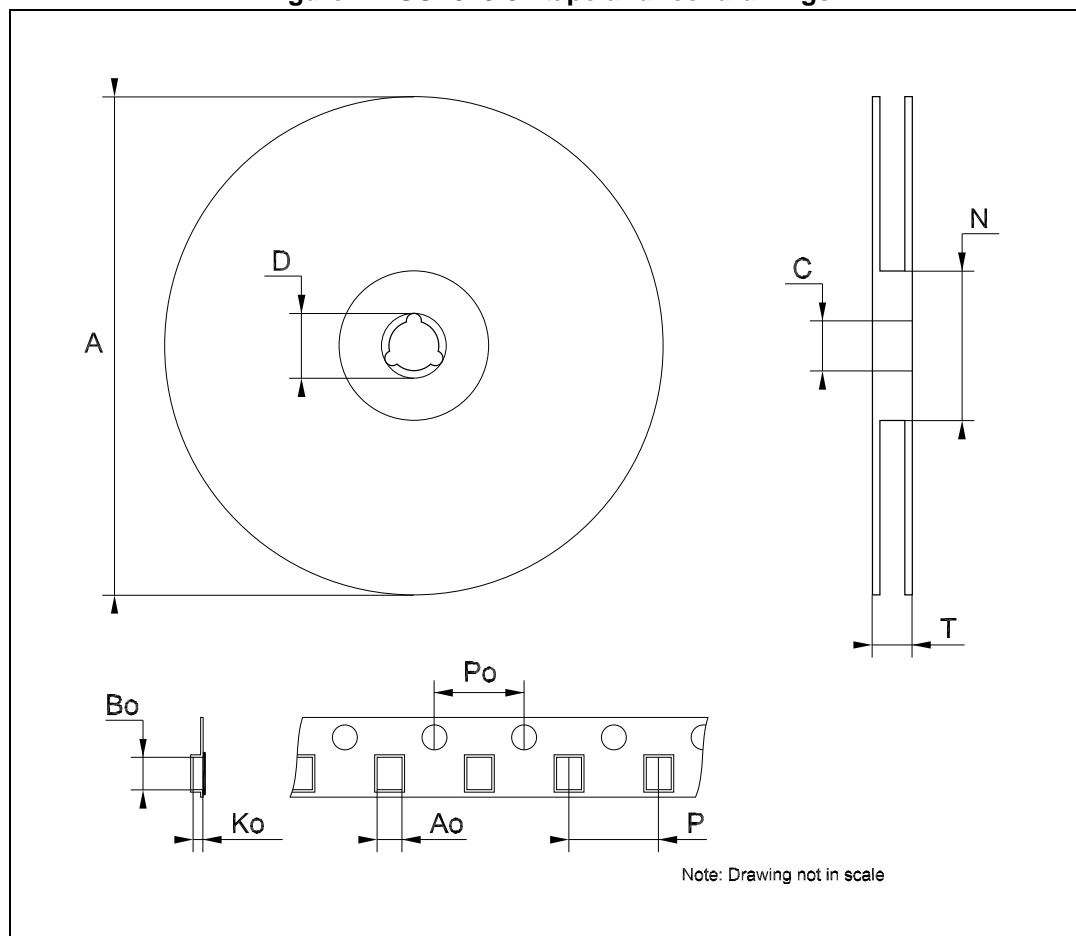

Table 7. SOT323-5L tape and reel mechanical data

Dim.	mm		
	Min.	Typ.	Max.
A	175	180	185
C	12.8	13	13.2
D	20.2		
N	59.5	60	60.5
T			14.4
Ao		2.25	
Bo		3.17	
Ko		1.2	
Po	3.9	4.0	4.1
P	3.9	4.0	4.2

9 Revision history

Table 8. Document revision history

Date	Revision	Changes
10-May-2010	1	Initial release.
21-Dec-2011	2	Modified: operating input voltage (V_{IN}) min. value Table 5 on page 7 . Availability LD59015C08R code Table 1 on page 1 .
06-Jul-2012	3	Updated: Table 1 on page 1 .
24-Apr-2014	4	Part number LD59015xx changed to LD59015. Updated the description in cover page and Section 7: Package mechanical data . Added Section 8: Packaging mechanical data . Minor text changes.

Please Read Carefully:

Information in this document is provided solely in connection with ST products. STMicroelectronics NV and its subsidiaries ("ST") reserve the right to make changes, corrections, modifications or improvements, to this document, and the products and services described herein at any time, without notice.

All ST products are sold pursuant to ST's terms and conditions of sale.

Purchasers are solely responsible for the choice, selection and use of the ST products and services described herein, and ST assumes no liability whatsoever relating to the choice, selection or use of the ST products and services described herein.

No license, express or implied, by estoppel or otherwise, to any intellectual property rights is granted under this document. If any part of this document refers to any third party products or services it shall not be deemed a license grant by ST for the use of such third party products or services, or any intellectual property contained therein or considered as a warranty covering the use in any manner whatsoever of such third party products or services or any intellectual property contained therein.

UNLESS OTHERWISE SET FORTH IN ST'S TERMS AND CONDITIONS OF SALE ST DISCLAIMS ANY EXPRESS OR IMPLIED WARRANTY WITH RESPECT TO THE USE AND/OR SALE OF ST PRODUCTS INCLUDING WITHOUT LIMITATION IMPLIED WARRANTIES OF MERCHANTABILITY, FITNESS FOR A PARTICULAR PURPOSE (AND THEIR EQUIVALENTS UNDER THE LAWS OF ANY JURISDICTION), OR INFRINGEMENT OF ANY PATENT, COPYRIGHT OR OTHER INTELLECTUAL PROPERTY RIGHT.

ST PRODUCTS ARE NOT DESIGNED OR AUTHORIZED FOR USE IN: (A) SAFETY CRITICAL APPLICATIONS SUCH AS LIFE SUPPORTING, ACTIVE IMPLANTED DEVICES OR SYSTEMS WITH PRODUCT FUNCTIONAL SAFETY REQUIREMENTS; (B) AERONAUTIC APPLICATIONS; (C) AUTOMOTIVE APPLICATIONS OR ENVIRONMENTS, AND/OR (D) AEROSPACE APPLICATIONS OR ENVIRONMENTS. WHERE ST PRODUCTS ARE NOT DESIGNED FOR SUCH USE, THE PURCHASER SHALL USE PRODUCTS AT PURCHASER'S SOLE RISK, EVEN IF ST HAS BEEN INFORMED IN WRITING OF SUCH USAGE, UNLESS A PRODUCT IS EXPRESSLY DESIGNATED BY ST AS BEING INTENDED FOR "AUTOMOTIVE, AUTOMOTIVE SAFETY OR MEDICAL" INDUSTRY DOMAINS ACCORDING TO ST PRODUCT DESIGN SPECIFICATIONS. PRODUCTS FORMALLY ESCC, QML OR JAN QUALIFIED ARE DEEMED SUITABLE FOR USE IN AEROSPACE BY THE CORRESPONDING GOVERNMENTAL AGENCY.

Resale of ST products with provisions different from the statements and/or technical features set forth in this document shall immediately void any warranty granted by ST for the ST product or service described herein and shall not create or extend in any manner whatsoever, any liability of ST.

ST and the ST logo are trademarks or registered trademarks of ST in various countries.
Information in this document supersedes and replaces all information previously supplied.

The ST logo is a registered trademark of STMicroelectronics. All other names are the property of their respective owners.

© 2014 STMicroelectronics - All rights reserved

STMicroelectronics group of companies

Australia - Belgium - Brazil - Canada - China - Czech Republic - Finland - France - Germany - Hong Kong - India - Israel - Italy - Japan - Malaysia - Malta - Morocco - Philippines - Singapore - Spain - Sweden - Switzerland - United Kingdom - United States of America

www.st.com



AMEYA360

Components Supply Platform

Authorized Distribution Brand :



Website :

Welcome to visit www.ameya360.com

Contact Us :

➤ Address :

401 Building No.5, JiuGe Business Center, Lane 2301, Yishan Rd
Minhang District, Shanghai , China

➤ Sales :

Direct +86 (21) 6401-6692

Email amall@ameya360.com

QQ 800077892

Skype [ameyasales1](#) [ameyasales2](#)

➤ Customer Service :

Email service@ameya360.com

➤ Partnership :

Tel +86 (21) 64016692-8333

Email mkt@ameya360.com