

525kHz/1.6MHz, Constant Current Boost and SEPIC LED Driver with Internal Compensation

Check for Samples: [LM3410](#), [LM3410Q](#)

FEATURES

- Space Saving SOT-23 and WSON Packages
- Input Voltage Range of 2.7V to 5.5V
- Output Voltage Range of 3V to 24V
- 2.8A Typical Switch Current
- High Switching Frequency
 - 525 KHz (LM3410Y)
 - 1.6 MHz (LM3410X)
- 170 mΩ NMOS Switch
- 190 mV Internal Voltage Reference
- Internal Soft-Start
- Current-Mode, PWM Operation
- Thermal Shutdown
- LM3410Q is AEC-Q100 Grade 1 Qualified and is Manufactured on an Automotive Grade Flow

DESCRIPTION

The LM3410 constant current LED driver is a monolithic, high frequency, PWM DC/DC converter in 5-pin

SOT-23, 6-pin WSON, and 8-pin MSOP-PowerPad™ packages. With a minimum of external components the LM3410 is easy to use. It can drive 2.8A typical peak currents with an internal 170 mΩ NMOS switch. Switching frequency is internally set to either 525 kHz or 1.60 MHz, allowing the use of extremely small surface mount inductors and chip capacitors. Even though the operating frequency is high, efficiencies up to 88% are easy to achieve. External shutdown is included, featuring an ultra-low standby current of 80 nA. The LM3410 utilizes current-mode control and internal compensation to provide high-performance over a wide range of operating conditions. Additional features include dimming, cycle-by-cycle current limit, and thermal shutdown.

APPLICATIONS

- LED Backlight Current Source
- Lilon Backlight OLED and HB LED Driver
- Handheld Devices
- LED Flash Driver
- Automotive

Typical Boost Application Circuit

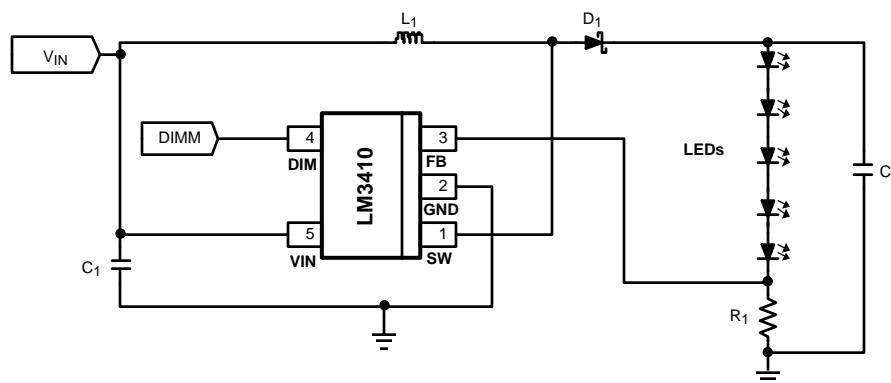

Please be aware that an important notice concerning availability, standard warranty, and use in critical applications of Texas Instruments semiconductor products and disclaimers thereto appears at the end of this data sheet.

PowerPad is a trademark of Texas Instruments.

All other trademarks are the property of their respective owners.

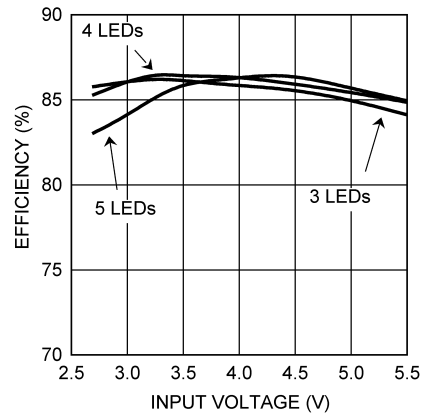

Connection Diagram

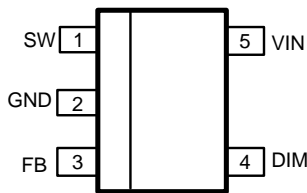

Figure 1. 5-Pin SOT-23 (Top View)
See DBV Package

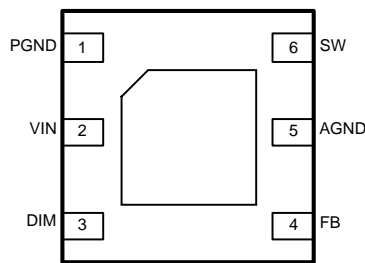

Figure 2. 6-Pin WSON (Top View)
See NGG0006A Package

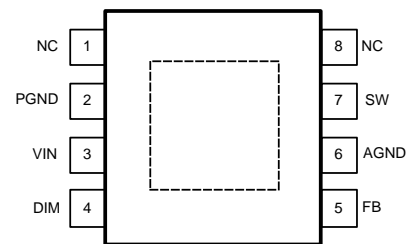

Figure 3. 8-Pin MSOP-PowerPad (Top View)
See GDN0008A Package

Table 1. Pin Descriptions - 5-Pin SOT-23

Pin	Name	Function
1	SW	Output switch. Connect to the inductor, output diode.
2	GND	Signal and power ground pin. Place the bottom resistor of the feedback network as close as possible to this pin.
3	FB	Feedback pin. Connect FB to external resistor divider to set output voltage.
4	DIM	Dimming and shutdown control input. Logic high enables operation. Duty Cycle from 0 to 100%. Do not allow this pin to float or be greater than VIN + 0.3V.
5	VIN	Supply voltage pin for power stage, and input supply voltage.

Table 2. Pin Descriptions - 6-Pin WSON

Pin	Name	Function
1	PGND	Power ground pin. Place PGND and output capacitor GND close together.
2	VIN	Supply voltage for power stage, and input supply voltage.
3	DIM	Dimming and shutdown control input. Logic high enables operation. Duty Cycle from 0 to 100%. Do not allow this pin to float or be greater than VIN + 0.3V.
4	FB	Feedback pin. Connect FB to external resistor divider to set output voltage.
5	AGND	Signal ground pin. Place the bottom resistor of the feedback network as close as possible to this pin and pin 4.
6	SW	Output switch. Connect to the inductor, output diode.
DAP	GND	Signal and Power ground. Connect to pin 1 and pin 5 on top layer. Place 4-6 vias from DAP to bottom layer GND plane.

Table 3. Pin Descriptions - 8-Pin MSOP-PowerPad

Pin	Name	Function
1	-	No Connect
2	PGND	Power ground pin. Place PGND and output capacitor GND close together.
3	VIN	Supply voltage for power stage, and input supply voltage.
4	DIM	Dimming and shutdown control input. Logic high enables operation. Duty Cycle from 0 to 100%. Do not allow this pin to float or be greater than $V_{IN} + 0.3V$.
5	FB	Feedback pin. Connect FB to external resistor divider to set output voltage.
6	AGND	Signal ground pin. Place the bottom resistor of the feedback network as close as possible to this pin and pin 5
7	SW	Output switch. Connect to the inductor, output diode.
8	-	No Connect
DAP	GND	Signal and Power ground. Connect to pin 2 and pin 6 on top layer. Place 4-6 vias from DAP to bottom layer GND plane.



These devices have limited built-in ESD protection. The leads should be shorted together or the device placed in conductive foam during storage or handling to prevent electrostatic damage to the MOS gates.

Absolute Maximum Ratings ⁽¹⁾⁽²⁾

V_{IN}		-0.5V to 7V
SW Voltage		-0.5V to 26.5V
FB Voltage		-0.5V to 3.0V
DIM Voltage		-0.5V to 7.0V
ESD Susceptibility ⁽³⁾	Human Body Model	2kV
Junction Temperature ⁽⁴⁾		150°C
Storage Temp. Range		-65°C to 150°C
Soldering Information	Infrared/Convection Reflow (15sec)	220°C

- (1) Absolute Maximum Ratings indicate limits beyond which damage to the device may occur. Operating Ratings indicate conditions for which the device is intended to be functional, but does not ensure specific performance limits. For ensured specifications and conditions, see the Electrical Characteristics.
- (2) If Military/Aerospace specified devices are required, please contact the TI Sales Office/ Distributors for availability and specifications.
- (3) The human body model is a 100 pF capacitor discharged through a 1.5 kΩ resistor into each pin. Test method is per JESD22-A114.
- (4) Thermal shutdown will occur if the junction temperature exceeds the maximum junction temperature of the device.

Operating Ratings ⁽¹⁾

V_{IN}		2.7V to 5.5V
$V_{DIM}^{(2)}$		0V to V_{IN}
V_{SW}		3V to 24V
Junction Temperature Range		-40°C to 125°C
Power Dissipation (Internal) SOT-23		400 mW

- (1) Absolute Maximum Ratings indicate limits beyond which damage to the device may occur. Operating Ratings indicate conditions for which the device is intended to be functional, but does not ensure specific performance limits. For ensured specifications and conditions, see the Electrical Characteristics.
- (2) Do not allow this pin to float or be greater than $V_{IN} + 0.3V$.

Electrical Characteristics

Limits in standard type are for $T_J = 25^\circ\text{C}$ only; limits in **boldface type** apply over the junction temperature (T_J) range of -40°C to 125°C . Minimum and Maximum limits are specified through test, design, or statistical correlation. Typical values represent the most likely parametric norm at $T_J = 25^\circ\text{C}$, and are provided for reference purposes only. $V_{IN} = 5\text{V}$, unless otherwise indicated under the Conditions column.

Symbol	Parameter	Conditions	Min	Typ	Max	Units
V_{FB}	Feedback Voltage		178	190	202	mV
$\Delta V_{FB}/V_{IN}$	Feedback Voltage Line Regulation	$V_{IN} = 2.7\text{V to } 5.5\text{V}$	-	0.06	-	%/V
I_{FB}	Feedback Input Bias Current		-	0.1	1	μA
F_{SW}	Switching Frequency	LM3410X	1200	1600	2000	kHz
		LM3410Y	360	525	680	
D_{MAX}	Maximum Duty Cycle	LM3410X	88	92	-	%
		LM3410Y	90	95	-	
D_{MIN}	Minimum Duty Cycle	LM3410X	-	5	-	%
		LM3410Y	-	2	-	
$R_{DS(ON)}$	Switch On Resistance	SOT-23 and MSOP-PowerPad	-	170	330	m Ω
		WSON	-	190	350	
I_{CL}	Switch Current Limit		2.1	2.80	-	A
SU	Start Up Time		-	20	-	μs
I_Q	Quiescent Current (switching)	LM3410X $V_{FB} = 0.25$	-	7.0	11	mA
		LM3410Y $V_{FB} = 0.25$	-	3.4	7	
	Quiescent Current (shutdown)	All Options $V_{DIM} = 0\text{V}$	-	80	-	nA
UVLO	Undervoltage Lockout	V_{IN} Rising	-	2.3	2.65	V
		V_{IN} Falling	1.7	1.9	-	
V_{DIM_H}	Shutdown Threshold Voltage		-	-	0.4	V
	Enable Threshold Voltage		1.8	-	-	
I_{SW}	Switch Leakage	$V_{SW} = 24\text{V}$	-	1.0	-	μA
I_{DIM}	Dimming Pin Current	Sink/Source	-	100	-	nA
θ_{JA}	Junction to Ambient 0 LFPM Air Flow ⁽¹⁾	WSON and MSOP-PowerPad Packages	-	80	-	$^\circ\text{C/W}$
		SOT-23 Package	-	118	-	
θ_{JC}	Junction to Case ⁽¹⁾	WSON and MSOP-PowerPad Packages	-	18	-	$^\circ\text{C/W}$
		SOT-23 Package	-	60	-	
T_{SD}	Thermal Shutdown Temperature ⁽²⁾		-	165	-	$^\circ\text{C}$

(1) Applies for packages soldered directly onto a 3" x 3" PC board with 2oz. copper on 4 layers in still air.

(2) Thermal shutdown will occur if the junction temperature exceeds the maximum junction temperature of the device.

Typical Performance Characteristics

All curves taken at $V_{IN} = 5.0V$ with configuration in typical application circuit shown in [Application Information](#) section of this datasheet. $T_J = 25C$, unless otherwise specified.

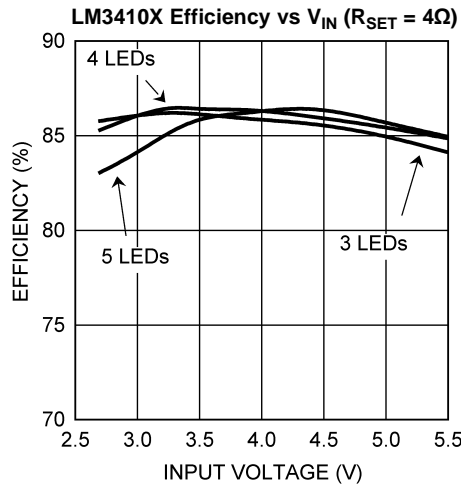

Figure 4.

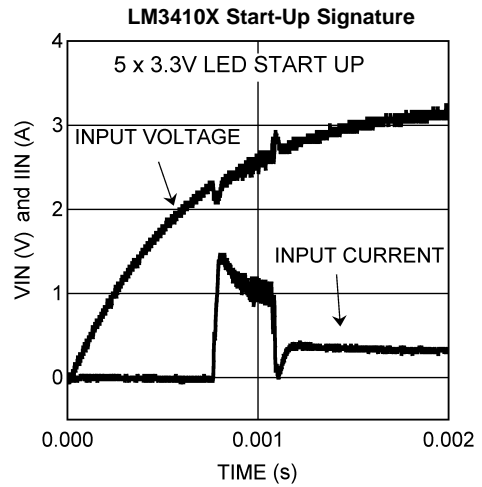

Figure 5.

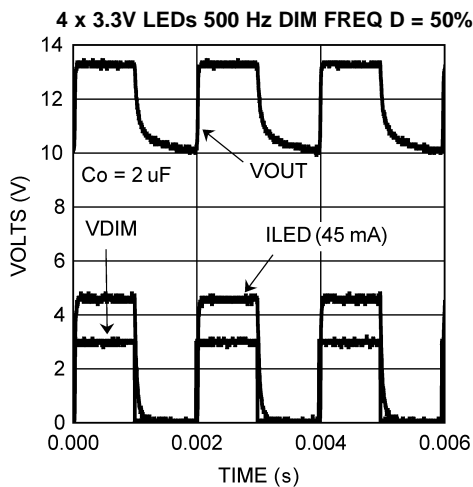

Figure 6.

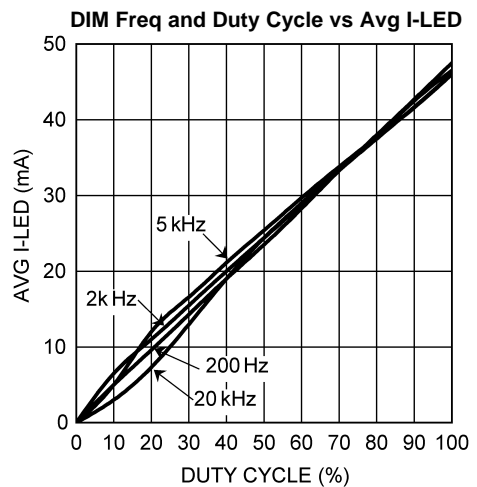

Figure 7.

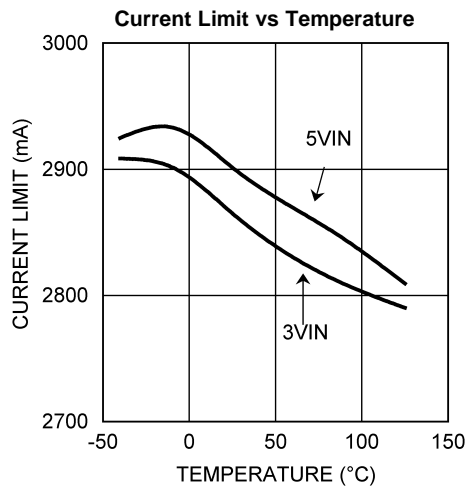

Figure 8.

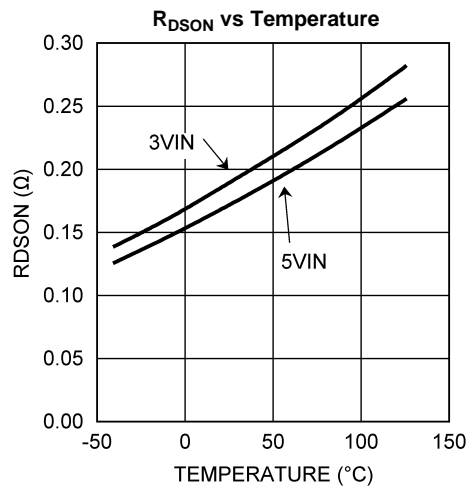

Figure 9.

Typical Performance Characteristics (continued)

All curves taken at $V_{IN} = 5.0V$ with configuration in typical application circuit shown in [Application Information](#) section of this datasheet. $T_J = 25C$, unless otherwise specified.

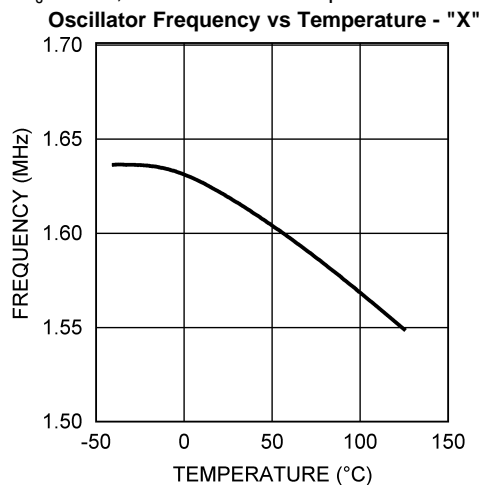

Figure 10.

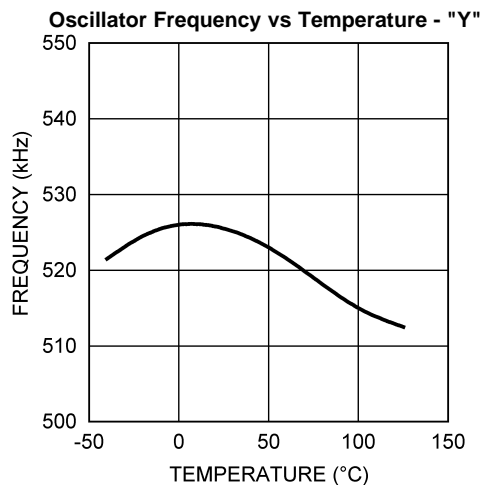

Figure 11.

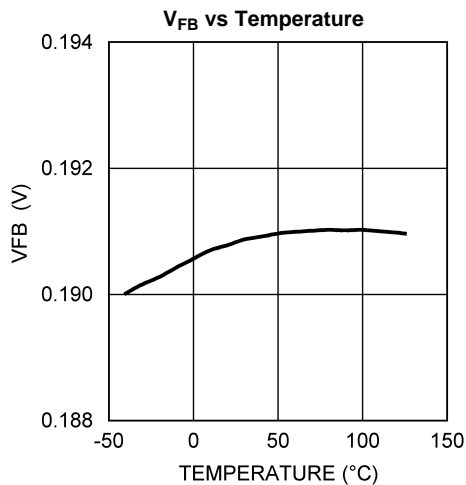

Figure 12.

Simplified Internal Block Diagram

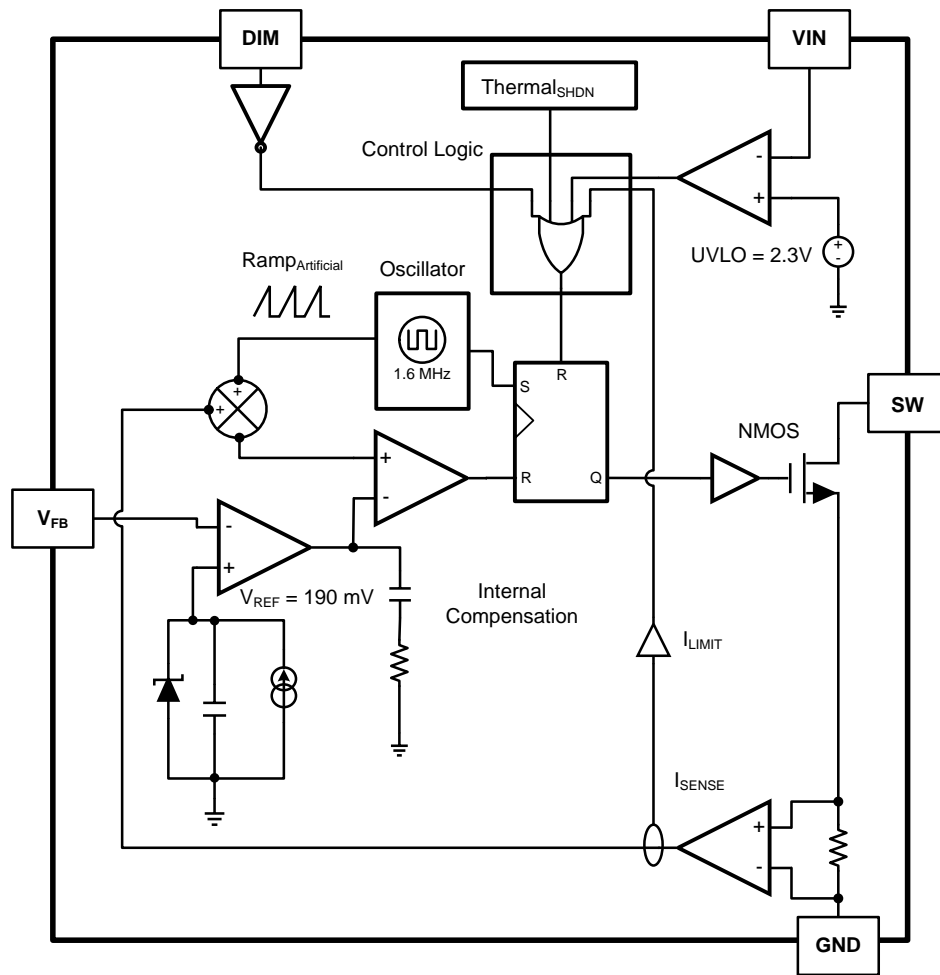

Figure 13. Simplified Block Diagram

APPLICATION INFORMATION

THEORY OF OPERATION

The LM3410 is a constant frequency PWM, boost regulator IC. It delivers a minimum of 2.1A peak switch current. The device operates very similar to a voltage regulated boost converter except that it regulates the output current through LEDs. The current magnitude is set with a series resistor. This series resistor multiplied by the LED current creates the feedback voltage (190 mV) which the converter regulates to. The regulator has a preset switching frequency of either 525 kHz or 1.60 MHz. This high frequency allows the LM3410 to operate with small surface mount capacitors and inductors, resulting in a DC/DC converter that requires a minimum amount of board space. The LM3410 is internally compensated, so it is simple to use, and requires few external components. The LM3410 uses current-mode control to regulate the LED current. The following operating description of the LM3410 will refer to the Simplified Block Diagram (Figure 13) the simplified schematic (Figure 14), and its associated waveforms (Figure 15). The LM3410 supplies a regulated LED current by switching the internal NMOS control switch at constant frequency and variable duty cycle. A switching cycle begins at the falling edge of the reset pulse generated by the internal oscillator. When this pulse goes low, the output control logic turns on the internal NMOS control switch. During this on-time, the SW pin voltage (V_{SW}) decreases to approximately GND, and the inductor current (I_L) increases with a linear slope. I_L is measured by the current sense amplifier, which generates an output proportional to the switch current. The sensed signal is summed with the regulator's corrective ramp and compared to the error amplifier's output, which is proportional to the difference between the feedback voltage and V_{REF} . When the PWM comparator output goes high, the output switch turns off until the next switching cycle begins. During the switch off-time, inductor current discharges through diode D1, which forces the SW pin to swing to the output voltage plus the forward voltage (V_D) of the diode. The regulator loop adjusts the duty cycle (D) to maintain a regulated LED current.

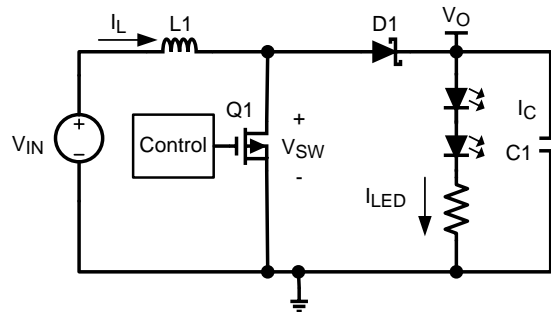

Figure 14. Simplified Boost Topology Schematic

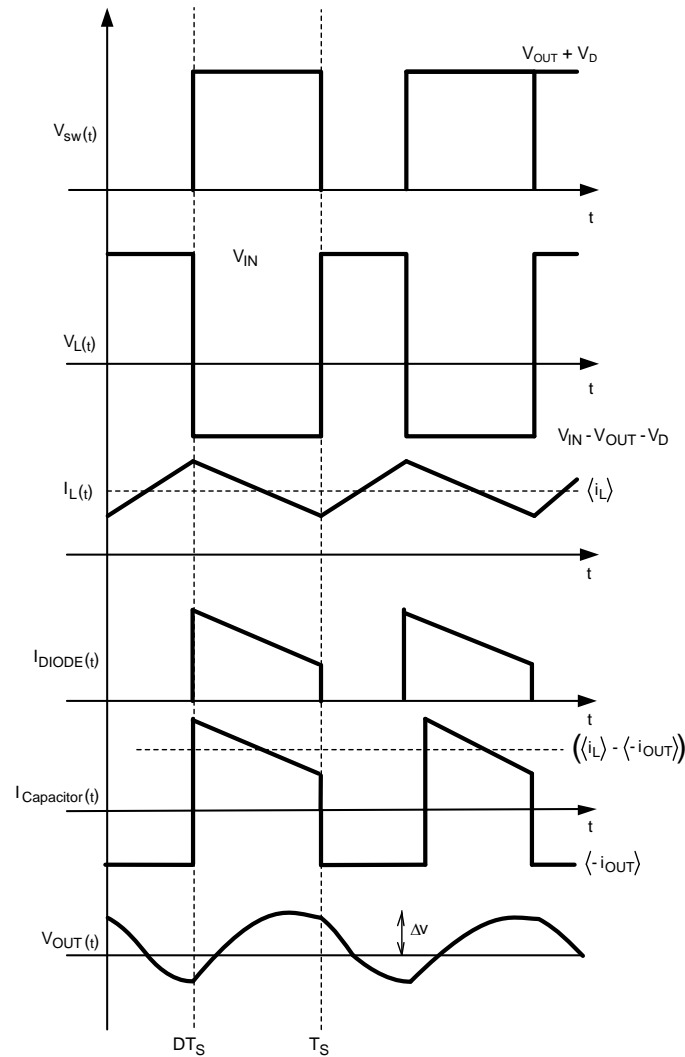

Figure 15. Typical Waveforms

CURRENT LIMIT

The LM3410 uses cycle-by-cycle current limiting to protect the internal NMOS switch. It is important to note that this current limit will not protect the output from excessive current during an output short circuit. The input supply is connected to the output by the series connection of an inductor and a diode. If a short circuit is placed on the output, excessive current can damage both the inductor and diode.

Design Guide

SETTING THE LED CURRENT

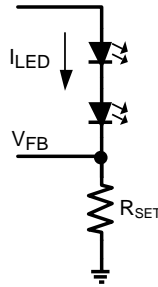

Figure 16. Setting I_{LED}

The LED current is set using the following equation:

$$\frac{V_{FB}}{R_{SET}} = I_{LED}$$

where

- R_{SET} is connected between the FB pin and GND. (1)

DIM PIN / SHUTDOWN MODE

The average LED current can be controlled using a PWM signal on the DIM pin. The duty cycle can be varied between 0 and 100% to either increase or decrease LED brightness. PWM frequencies in the range of 1 Hz to 25 kHz can be used. For controlling LED currents down to the μA levels, it is best to use a PWM signal frequency between 200 and 1 kHz. The maximum LED current would be achieved using a 100% duty cycle, i.e. the DIM pin always high.

LED-DRIVE CAPABILITY

When using the LM3410 in the typical application configuration, with LEDs stacked in series between the VOUT and FB pin, the maximum number of LEDs that can be placed in series is dependent on the maximum LED forward voltage ($V_{F_{MAX}}$).

$$(V_{F_{MAX}} \times N_{LEDs}) + 190 \text{ mV} < 24\text{V} \quad (2)$$

When inserting a value for maximum $V_{F_{MAX}}$ the LED forward voltage variation over the operating temperature range should be considered.

THERMAL SHUTDOWN

Thermal shutdown limits total power dissipation by turning off the output switch when the IC junction temperature exceeds 165°C. After thermal shutdown occurs, the output switch doesn't turn on until the junction temperature drops to approximately 150°C.

INDUCTOR SELECTION

The inductor value determines the input ripple current. Lower inductor values decrease the physical size of the inductor, but increase the input ripple current. An increase in the inductor value will decrease the input ripple current.

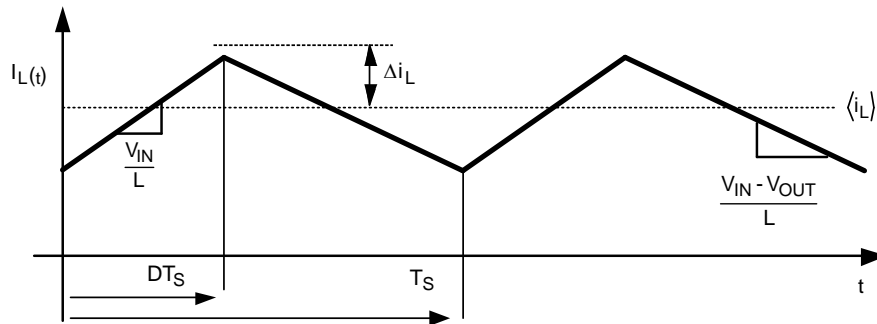

Figure 17. Inductor Current

$$\frac{2\Delta i_L}{DT_S} = \left(\frac{V_{IN}}{L}\right)$$

$$\Delta i_L = \left(\frac{V_{IN}}{2L}\right) \times DT_S \quad (3)$$

The Duty Cycle (D) for a Boost converter can be approximated by using the ratio of output voltage (V_{OUT}) to input voltage (V_{IN}).

$$\frac{V_{OUT}}{V_{IN}} = \left(\frac{1}{1 - D}\right) = \frac{1}{D'} \quad (4)$$

Therefore:

$$D = \frac{V_{OUT} - V_{IN}}{V_{OUT}} \quad (5)$$

Power losses due to the diode (D1) forward voltage drop, the voltage drop across the internal NMOS switch, the voltage drop across the inductor resistance (R_{DCR}) and switching losses must be included to calculate a more accurate duty cycle (See [Calculating Efficiency and Junction Temperature](#) for a detailed explanation). A more accurate formula for calculating the conversion ratio is:

$$\frac{V_{OUT}}{V_{IN}} = \frac{\eta}{D'}$$

Where

- η equals the efficiency of the LM3410 application. (6)

Or:

$$\eta = \frac{V_{OUT} \times I_{LED}}{V_{IN} \times I_{IN}} \quad (7)$$

Therefore:

$$D = \frac{V_{OUT} - \eta V_{IN}}{V_{OUT}} \quad (8)$$

Inductor ripple in a LED driver circuit can be greater than what would normally be allowed in a voltage regulator Boost and Sepic design. A good design practice is to allow the inductor to produce 20% to 50% ripple of maximum load. The increased ripple shouldn't be a problem when illuminating LEDs.

From the previous equations, the inductor value is then obtained.

$$L = \left(\frac{V_{IN}}{2\Delta i_L} \right) \times DT_s \quad (9)$$

Where

$$1/T_s = f_{sw} \quad (10)$$

One must also ensure that the minimum current limit (2.1A) is not exceeded, so the peak current in the inductor must be calculated. The peak current (I_{pk}) in the inductor is calculated by:

$$I_{Lpk} = I_{IN} + \Delta i_L \text{ or } I_{Lpk} = I_{OUT} / D' + \Delta i_L \quad (11)$$

When selecting an inductor, make sure that it is capable of supporting the peak input current without saturating. Inductor saturation will result in a sudden reduction in inductance and prevent the regulator from operating correctly. Because of the speed of the internal current limit, the peak current of the inductor need only be specified for the required maximum input current. For example, if the designed maximum input current is 1.5A and the peak current is 1.75A, then the inductor should be specified with a saturation current limit of >1.75A. There is no need to specify the saturation or peak current of the inductor at the 2.8A typical switch current limit.

Because of the operating frequency of the LM3410, ferrite based inductors are preferred to minimize core losses. This presents little restriction since the variety of ferrite-based inductors is huge. Lastly, inductors with lower series resistance (DCR) will provide better operating efficiency. For recommended inductors see **Example Circuits**.

INPUT CAPACITOR

An input capacitor is necessary to ensure that V_{IN} does not drop excessively during switching transients. The primary specifications of the input capacitor are capacitance, voltage, RMS current rating, and ESL (Equivalent Series Inductance). The recommended input capacitance is 2.2 μ F to 22 μ F depending on the application. The capacitor manufacturer specifically states the input voltage rating. Make sure to check any recommended deratings and also verify if there is any significant change in capacitance at the operating input voltage and the operating temperature. The ESL of an input capacitor is usually determined by the effective cross sectional area of the current path. At the operating frequencies of the LM3410, certain capacitors may have an ESL so large that the resulting impedance ($2\pi fL$) will be higher than that required to provide stable operation. As a result, surface mount capacitors are strongly recommended. Multilayer ceramic capacitors (MLCC) are good choices for both input and output capacitors and have very low ESL. For MLCCs it is recommended to use X7R or X5R dielectrics. Consult capacitor manufacturer datasheet to see how rated capacitance varies over operating conditions.

OUTPUT CAPACITOR

The LM3410 operates at frequencies allowing the use of ceramic output capacitors without compromising transient response. Ceramic capacitors allow higher inductor ripple without significantly increasing output ripple. The output capacitor is selected based upon the desired output ripple and transient response. The initial current of a load transient is provided mainly by the output capacitor. The output impedance will therefore determine the maximum voltage perturbation. The output ripple of the converter is a function of the capacitor's reactance and its equivalent series resistance (ESR):

$$\Delta V_{OUT} = \Delta i_L \times R_{ESR} + \left(\frac{V_{OUT} \times D}{2 \times f_{sw} \times R_{OUT} \times C_{OUT}} \right) \quad (12)$$

When using MLCCs, the ESR is typically so low that the capacitive ripple may dominate. When this occurs, the output ripple will be approximately sinusoidal and 90° phase shifted from the switching action.

Given the availability and quality of MLCCs and the expected output voltage of designs using the LM3410, there is really no need to review any other capacitor technologies. Another benefit of ceramic capacitors is their ability to bypass high frequency noise. A certain amount of switching edge noise will couple through parasitic capacitances in the inductor to the output. A ceramic capacitor will bypass this noise while a tantalum will not. Since the output capacitor is one of the two external components that control the stability of the regulator control loop, most applications will require a minimum at 0.47 μ F of output capacitance. Like the input capacitor, recommended multilayer ceramic capacitors are X7R or X5R. Again, verify actual capacitance at the desired operating voltage and temperature.

DIODE

The diode (D1) conducts during the switch off time. A Schottky diode is recommended for its fast switching times and low forward voltage drop. The diode should be chosen so that its current rating is greater than:

$$I_{D1} \geq I_{OUT} \quad (13)$$

The reverse breakdown rating of the diode must be at least the maximum output voltage plus appropriate margin.

OUTPUT OVER-VOLTAGE PROTECTION

A simple circuit consisting of an external zener diode can be implemented to protect the output and the LM3410 device from an over-voltage fault condition. If an LED fails open, or is connected backwards, an output open circuit condition will occur. No current is conducted through the LED's, and the feedback node will equal zero volts. The LM3410 will react to this fault by increasing the duty-cycle, thinking the LED current has dropped. A simple circuit that protects the LM3410 is shown in [Figure 18](#).

Zener diode D2 and resistor R3 is placed from V_{OUT} in parallel with the string of LEDs. If the output voltage exceeds the breakdown voltage of the zener diode, current is drawn through the zener diode, R3 and sense resistor R1. Once the voltage across R1 and R3 equals the feedback voltage of 190 mV, the LM3410 will limit its duty-cycle. No damage will occur to the LM3410, the LED's, or the zener diode. Once the fault is corrected, the application will work as intended.

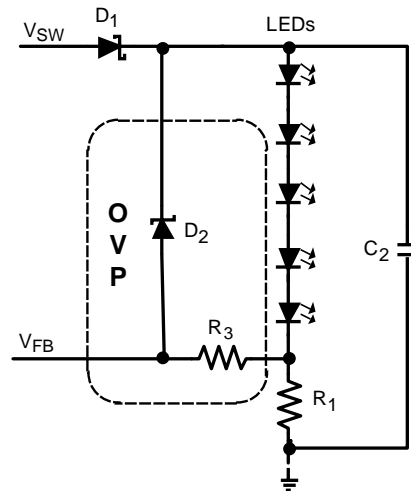

Figure 18. Overvoltage Protection Circuit

PCB Layout Considerations

When planning layout there are a few things to consider when trying to achieve a clean, regulated output. The most important consideration when completing a Boost Converter layout is the close coupling of the GND connections of the C_{OUT} capacitor and the LM3410 PGND pin. The GND ends should be close to one another and be connected to the GND plane with at least two through-holes. There should be a continuous ground plane on the bottom layer of a two-layer board except under the switching node island. The FB pin is a high impedance node and care should be taken to make the FB trace short to avoid noise pickup and inaccurate regulation. The R_{SET} feedback resistor should be placed as close as possible to the IC, with the AGND of R_{SET} (R_1) placed as close as possible to the AGND (pin 5 for the WSON) of the IC. Radiated noise can be decreased by choosing a shielded inductor. The remaining components should also be placed as close as possible to the IC. Please see TI Lit Number [SNVA054](#) for further considerations and the LM3410 demo board as an example of a four-layer layout.

Below is an example of a good thermal and electrical PCB design.

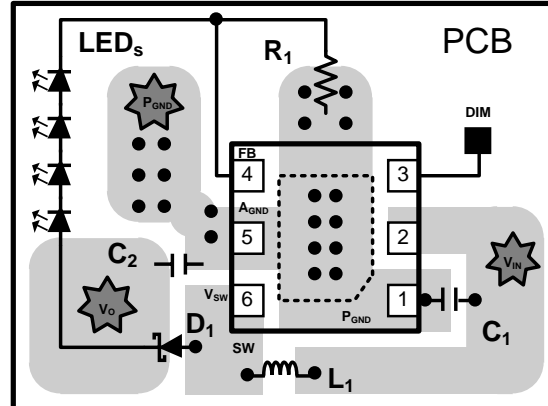

Figure 19. Boost PCB Layout Guidelines

This is very similar to our LM3410 demonstration boards that are obtainable via the Texas Instruments website. The demonstration board consists of a two layer PCB with a common input and output voltage application. Most of the routing is on the top layer, with the bottom layer consisting of a large ground plane. The placement of the external components satisfies the electrical considerations, and the thermal performance has been improved by adding thermal vias and a top layer "Dog-Bone".

For certain high power applications, the PCB land may be modified to a "dog bone" shape (see Figure 20). Increasing the size of ground plane and adding thermal vias can reduce the $R_{\theta JA}$ for the application.

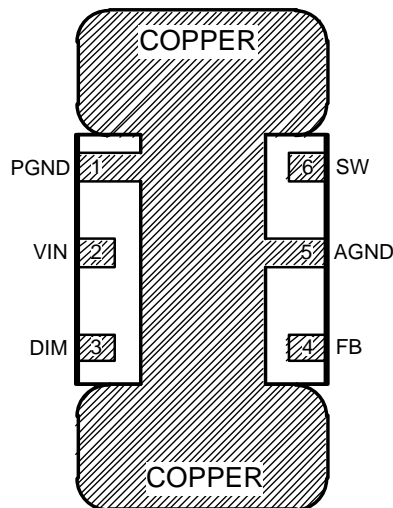

Figure 20. PCB Dog Bone Layout

Thermal Design

When designing for thermal performance, one must consider many variables:

Ambient Temperature: The surrounding maximum air temperature is fairly explanatory. As the temperature increases, the junction temperature will increase. This may not be linear though. As the surrounding air temperature increases, resistances of semiconductors, wires and traces increase. This will decrease the efficiency of the application, and more power will be converted into heat, and will increase the silicon junction temperatures further.

Forced Airflow: Forced air can drastically reduce the device junction temperature. Air flow reduces the hot spots within a design. Warm airflow is often much better than a lower ambient temperature with no airflow.

External Components: Choose components that are efficient, and you can reduce the mutual heating between devices.

PCB design with thermal performance in mind:

The PCB design is a very important step in the thermal design procedure. The LM3410 is available in three package options (5-pin SOT-23, 8-pin MSOP-PowerPad and 6-pin WSON). The options are electrically the same, but difference between the packages is size and thermal performance. The WSON and MSOP-PowerPad have thermal Die Attach Pads (DAP) attached to the bottom of the packages, and are therefore capable of dissipating more heat than the SOT-23 package. It is important that the customer choose the correct package for the application. A detailed thermal design procedure has been included in this data sheet. This procedure will help determine which package is correct, and common applications will be analyzed.

There is one significant thermal PCB layout design consideration that contradicts a proper electrical PCB layout design consideration. This contradiction is the placement of external components that dissipate heat. The greatest external heat contributor is the external Schottky diode. It would be nice if you were able to separate by distance the LM3410 from the Schottky diode, and thereby reducing the mutual heating effect. This will however create electrical performance issues. It is important to keep the LM3410, the output capacitor, and Schottky diode physically close to each other (see PCB layout guidelines). The electrical design considerations outweigh the thermal considerations. Other factors that influence thermal performance are thermal vias, copper weight, and number of board layers.

Thermal Definitions

Heat energy is transferred from regions of high temperature to regions of low temperature via three basic mechanisms: radiation, conduction and convection.

Radiation: Electromagnetic transfer of heat between masses at different temperatures.

Conduction: Transfer of heat through a solid medium.

Convection: Transfer of heat through the medium of a fluid; typically air.

Conduction and Convection will be the dominant heat transfer mechanism in most applications.

$R_{\theta JA}$: Thermal impedance from silicon junction to ambient air temperature.

$R_{\theta JC}$: Thermal impedance from silicon junction to device case temperature.

$C_{\theta JC}$: Thermal Delay from silicon junction to device case temperature.

$C_{\theta CA}$: Thermal Delay from device case to ambient air temperature.

$R_{\theta JA}$ and $R_{\theta JC}$: These two symbols represent thermal impedances, and most data sheets contain associated values for these two symbols. The units of measurement are °C/Watt.

$R_{\theta JA}$ is the sum of smaller thermal impedances (see simplified thermal model [Figure 21](#) and [Figure 22](#)).

Capacitors within the model represent delays that are present from the time that power and its associated heat is increased or decreased from steady state in one medium until the time that the heat increase or decrease reaches steady state in the another medium.

The datasheet values for these symbols are given so that one might compare the thermal performance of one package against another. To achieve a comparison between packages, all other variables must be held constant in the comparison (PCB size, copper weight, thermal vias, power dissipation, V_{IN} , V_{OUT} , load current etc). This does shed light on the package performance, but it would be a mistake to use these values to calculate the actual junction temperature in your application.

LM3410 Thermal Models

Heat is dissipated from the LM3410 and other devices. The external loss elements include the Schottky diode, inductor, and loads. All loss elements will mutually increase the heat on the PCB, and therefore increase each other's temperatures.

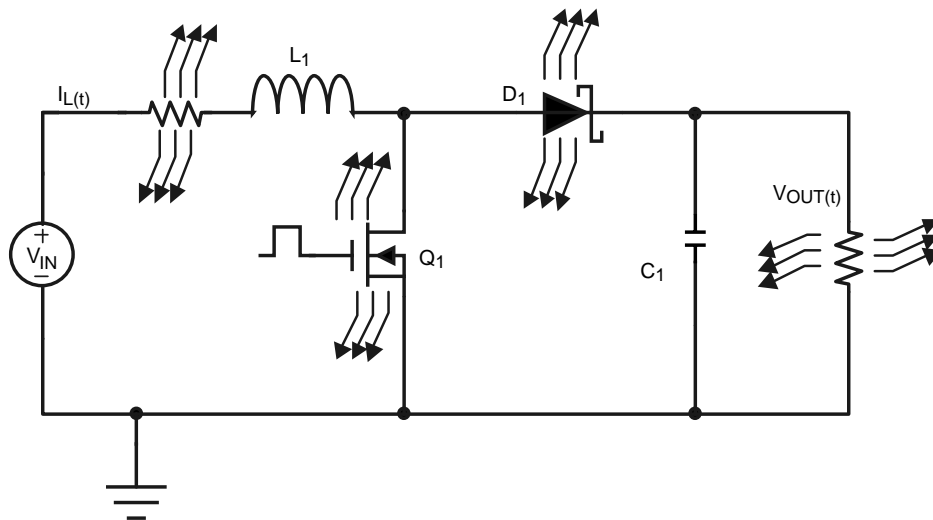

Figure 21. Thermal Schematic

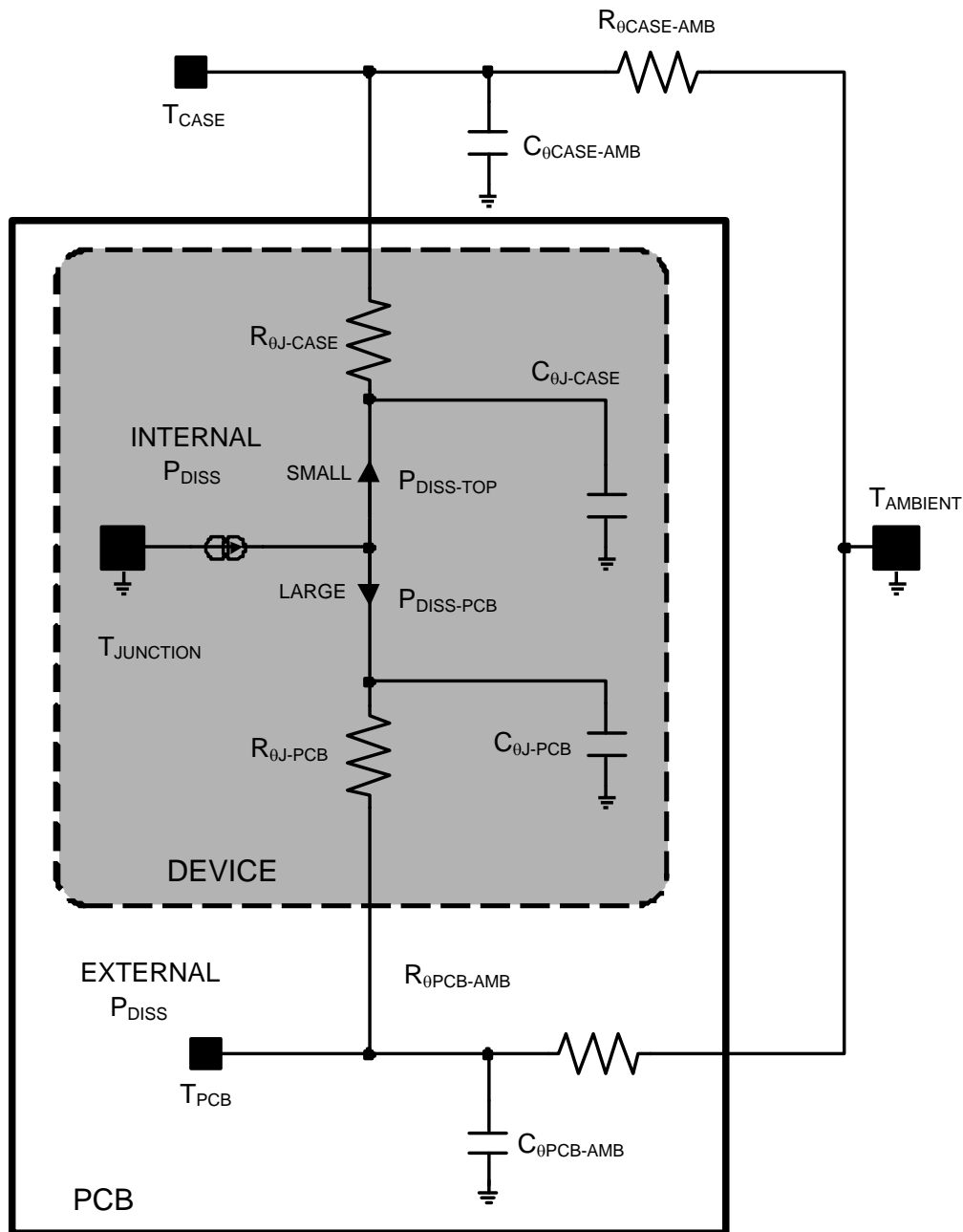

Figure 22. Associated Thermal Model

Calculating Efficiency and Junction Temperature

We will talk more about calculating proper junction temperature with relative certainty in a moment. For now we need to describe how to calculate the junction temperature and clarify some common misconceptions.

$$R_{\theta JA} = \frac{T_J - T_A}{P_{\text{Dissipation}}} \quad (14)$$

A common error when calculating $R_{\theta JA}$ is to assume that the package is the only variable to consider.

$R_{\theta JA}$ [variables]:

- Input Voltage, Output Voltage, Output Current, $R_{DS(ON)}$
- Ambient temperature and air flow
- Internal and External components power dissipation
- Package thermal limitations
- PCB variables (copper weight, thermal via's, layers component placement)

Another common error when calculating junction temperature is to assume that the top case temperature is the proper temperature when calculating $R_{\theta JC}$. $R_{\theta JC}$ represents the thermal impedance of all six sides of a package, not just the top side. This document will refer to a thermal impedance called $R_{\psi JC}$. $R_{\psi JC}$ represents a thermal impedance associated with just the top case temperature. This will allow one to calculate the junction temperature with a thermal sensor connected to the top case.

The complete LM3410 Boost converter efficiency can be calculated in the following manner.

$$\eta = \frac{P_{OUT}}{P_{IN}}$$

or

$$\eta = \frac{P_{OUT}}{P_{OUT} + P_{LOSS}} \quad (15)$$

Power loss (P_{LOSS}) is the sum of two types of losses in the converter, switching and conduction. Conduction losses usually dominate at higher output loads, where as switching losses remain relatively fixed and dominate at lower output loads.

Losses in the LM3410 Device:

$$P_{LOSS} = P_{COND} + P_{SW} + P_Q$$

Where

- P_Q = quiescent operating power loss (16)

Conversion ratio of the Boost Converter with conduction loss elements inserted:

$$\frac{V_{OUT}}{V_{IN}} = \frac{1}{D'} \left(1 - \frac{D' \times V_D}{V_{IN}} \right) \left(\frac{1}{1 + \frac{R_{DCR} + (D \times R_{DSON})}{D'^2 R_{OUT}}} \right)$$

Where

- R_{DCR} = Inductor series resistance (17)

$$R_{OUT} = \frac{V_{OUT}}{I_{LED}} \quad (18)$$

One can see that if the loss elements are reduced to zero, the conversion ratio simplifies to:

$$\frac{V_{OUT}}{V_{IN}} = \frac{1}{D'} \quad (19)$$

And we know:

$$\frac{V_{OUT}}{V_{IN}} = \frac{\eta}{D'} \quad (20)$$

Therefore:

$$\eta = D' \frac{V_{OUT}}{V_{IN}} = \left(\frac{1 - \frac{D' \times V_D}{V_{IN}}}{1 + \frac{R_{DCR} + (D \times R_{DSON})}{D'^2 R_{OUT}}} \right) \quad (21)$$

Calculations for determining the most significant power losses are discussed below. Other losses totaling less than 2% are not discussed.

A simple efficiency calculation that takes into account the conduction losses is shown below:

$$\eta \approx \left(\frac{1 - \frac{D' \times V_D}{V_{IN}}}{1 + \frac{R_{DCR} + (D \times R_{DSON})}{D'^2 R_{OUT}}} \right) \quad (22)$$

The diode, NMOS switch, and inductor DCR losses are included in this calculation. Setting any loss element to zero will simplify the equation.

V_D is the forward voltage drop across the Schottky diode. It can be obtained from the manufacturer's [Electrical Characteristics](#) section of the data sheet.

The conduction losses in the diode are calculated as follows:

$$P_{DIODE} = V_D \times I_{LED} \quad (23)$$

Depending on the duty cycle, this can be the single most significant power loss in the circuit. Care should be taken to choose a diode that has a low forward voltage drop. Another concern with diode selection is reverse leakage current. Depending on the ambient temperature and the reverse voltage across the diode, the current being drawn from the output to the NMOS switch during time D could be significant, this may increase losses internal to the LM3410 and reduce the overall efficiency of the application. Refer to Schottky diode manufacturer's data sheets for reverse leakage specifications, and typical applications within this data sheet for diode selections.

Another significant external power loss is the conduction loss in the input inductor. The power loss within the inductor can be simplified to:

$$P_{IND} = I_{IN}^2 R_{DCR} \quad (24)$$

Or

$$P_{IND} = \left(\frac{I_O^2 R_{DCR}}{D'} \right) \quad (25)$$

The LM3410 conduction loss is mainly associated with the internal power switch:

$$P_{COND-NFET} = I_{SW-rms}^2 \times R_{DSON} \times D \quad (26)$$

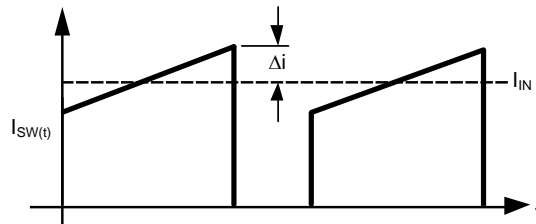

Figure 23. LM3410 Switch Current

$$I_{SW-RMS} = I_{IND} \sqrt{D} \times \sqrt{1 + \frac{1}{3} \left(\frac{\Delta i}{I_{IND}} \right)^2} \approx I_{IND} \sqrt{D} \quad (27)$$

(small ripple approximation)

$$P_{COND-NFET} = I_{IN}^2 \times R_{DSON} \times D \quad (28)$$

Or

$$P_{COND-NFET} = \left(\frac{I_{LED}}{D} \right)^2 \times R_{DSON} \times D \quad (29)$$

The value for R_{DSON} should be equal to the resistance at the junction temperature you wish to analyze. As an example, at 125°C and $R_{DSON} = 250 \text{ m}\Omega$ (See typical graphs for value).

Switching losses are also associated with the internal power switch. They occur during the switch on and off transition periods, where voltages and currents overlap resulting in power loss.

The simplest means to determine this loss is to empirically measuring the rise and fall times (10% to 90%) of the switch at the switch node:

$$P_{SWR} = 1/2(V_{OUT} \times I_{IN} \times f_{SW} \times t_{RISE}) \quad (30)$$

$$P_{SWF} = 1/2(V_{OUT} \times I_{IN} \times f_{SW} \times t_{FALL}) \quad (31)$$

$$P_{SW} = P_{SWR} + P_{SWF} \quad (32)$$

Table 4. Typical Switch-Node Rise and Fall Times

V_{IN}	V_{OUT}	t_{RISE}	t_{FALL}
3V	5V	6nS	4nS
5V	12V	6nS	5nS
3V	12V	8nS	7nS
5V	18V	10nS	8nS

Quiescent Power Losses

I_Q is the quiescent operating current, and is typically around 1.5 mA.

$$P_Q = I_Q \times V_{IN} \quad (33)$$

R_{SET} Power Loss

$$P_{RSET} = \frac{V_{FB}^2}{R_{SET}} \quad (34)$$

Example Efficiency Calculation:

Operating Conditions:

$$5 \times 3.3V \text{ LEDs} + 190mV_{REF} \approx 16.7V \quad (35)$$

Table 5. Operating Conditions

V_{IN}	3.3V
V_{OUT}	16.7V
I_{LED}	50mA
V_D	0.45V
f_{SW}	1.60MHz
I_Q	3mA
t_{RISE}	10nS
t_{FALL}	10nS
R_{DSON}	225m Ω
L_{DCR}	75m Ω
D	0.82
I_{IN}	0.31A

$$\Sigma P_{COND} + P_{SW} + P_{DIODE} + P_{IND} + P_Q = P_{LOSS} \quad (36)$$

Quiescent Power Loss:

$$P_Q = I_Q \times V_{IN} = 10 \text{ mW} \quad (37)$$

Switching Power Loss:

$$P_{SWR} = 1/2(V_{OUT} \times I_{IN} \times f_{SW} \times t_{RISE}) \approx 40 \text{ mW} \quad (38)$$

$$P_{SWF} = 1/2(V_{OUT} \times I_{IN} \times f_{SW} \times t_{FALL}) \approx 40 \text{ mW} \quad (39)$$

$$P_{SW} = P_{SWR} + P_{SWF} = 80 \text{ mW} \quad (40)$$

Internal NFET Power Loss:

$$R_{DSON} = 225 \text{ m}\Omega \quad (41)$$

$$P_{CONDUCTION} = I_{IN}^2 \times D \times R_{DSON} = 17 \text{ mW} \quad (42)$$

$$I_{IN} = 310 \text{ mA} \quad (43)$$

Diode Loss:

$$V_D = 0.45V \quad (44)$$

$$P_{DIODE} = V_D \times I_{LED} = 23 \text{ mW} \quad (45)$$

Inductor Power Loss:

$$R_{DCR} = 75 \text{ m}\Omega \quad (46)$$

$$P_{IND} = I_{IN}^2 \times R_{DCR} = 7 \text{ mW} \quad (47)$$

Total Power Losses are:
Table 6. Power Loss Tabulation

V_{IN}	3.3V		
V_{OUT}	16.7V		
I_{LED}	50mA	P_{OUT}	825W
V_D	0.45V	P_{DIODE}	23mW
f_{SW}	1.6MHz		
I_Q	10nS	P_{SWR}	40mW
t_{RISE}	10nS	P_{SWF}	40mW
I_Q	3mA	P_Q	10mW
R_{DSON}	225m Ω	P_{COND}	17mW
L_{DCR}	75m Ω	P_{IND}	7mW
D	0.82		
η	85%	P_{LOSS}	137mW

$$P_{\text{INTERNAL}} = P_{\text{COND}} + P_{\text{SW}} = 107 \text{ mW} \quad (48)$$

Calculating $R_{\theta\text{JA}}$ and $R_{\psi\text{JC}}$

$$R_{\theta\text{JA}} = \frac{T_{\text{J}} - T_{\text{A}}}{P_{\text{Dissipation}}} ; R_{\psi\text{JC}} = \frac{T_{\text{J}} - T_{\text{Case}}}{P_{\text{Dissipation}}} \quad (49)$$

We now know the internal power dissipation, and we are trying to keep the junction temperature at or below 125°C. The next step is to calculate the value for $R_{\theta\text{JA}}$ and/or $R_{\psi\text{JC}}$. This is actually very simple to accomplish, and necessary if you think you may be marginal with regards to thermals or determining what package option is correct.

The LM3410 has a thermal shutdown comparator. When the silicon reaches a temperature of 165°C, the device shuts down until the temperature drops to 150°C. Knowing this, one can calculate the $R_{\theta\text{JA}}$ or the $R_{\psi\text{JC}}$ of a specific application. Because the junction to top case thermal impedance is much lower than the thermal impedance of junction to ambient air, the error in calculating $R_{\psi\text{JC}}$ is lower than for $R_{\theta\text{JA}}$. However, you will need to attach a small thermocouple onto the top case of the LM3410 to obtain the $R_{\psi\text{JC}}$ value.

Knowing the temperature of the silicon when the device shuts down allows us to know three of the four variables. Once we calculate the thermal impedance, we then can work backwards with the junction temperature set to 125°C to see what maximum ambient air temperature keeps the silicon below the 125°C temperature.

Procedure:

Place your application into a thermal chamber. You will need to dissipate enough power in the device so you can obtain a good thermal impedance value.

Raise the ambient air temperature until the device goes into thermal shutdown. Record the temperatures of the ambient air and/or the top case temperature of the LM3410. Calculate the thermal impedances.

Example from previous calculations (SOT-23 Package):

$$P_{\text{INTERNAL}} = 107 \text{ mW} \quad (50)$$

$$T_{\text{A}} @ \text{Shutdown} = 155^{\circ}\text{C} \quad (51)$$

$$T_{\text{C}} @ \text{Shutdown} = 159^{\circ}\text{C} \quad (52)$$

$$R_{\theta\text{JA}} = \frac{T_{\text{J}} - T_{\text{A}}}{P_{\text{Dissipation}}} ; R_{\psi\text{JC}} = \frac{T_{\text{J}} - T_{\text{Case-Top}}}{P_{\text{Dissipation}}} \quad (53)$$

$$R_{\theta\text{JA}} \text{ SOT-23} = 93^{\circ}\text{C/W} \quad (54)$$

$$R_{\psi\text{JC}} \text{ SOT-23} = 56^{\circ}\text{C/W} \quad (55)$$

Typical WSON and MSOP-PowerPad typical applications will produce $R_{\theta\text{JA}}$ numbers in the range of 50°C/W to 65°C/W, and $R_{\psi\text{JC}}$ will vary between 18°C/W and 28°C/W. These values are for PCB's with two and four layer boards with 0.5 oz copper, and four to six thermal vias to bottom side ground plane under the DAP. The thermal impedances calculated above are higher due to the small amount of power being dissipated within the device.

Note: To use these procedures it is important to dissipate an amount of power within the device that will indicate a true thermal impedance value. If one uses a very small internal dissipated value, one can see that the thermal impedance calculated is abnormally high, and subject to error. [Figure 24](#) shows the nonlinear relationship of internal power dissipation vs. $R_{\theta\text{JA}}$.

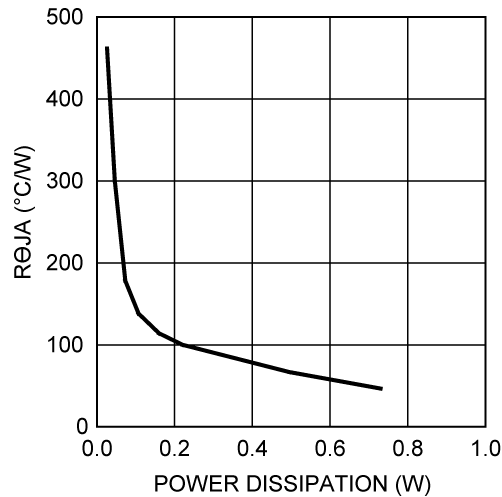

Figure 24. R_{θJA} vs Internal Dissipation

For 5-pin SOT-23 package typical applications, R_{θJA} numbers will range from 80°C/W to 110°C/W, and R_{ψJC} will vary between 50°C/W and 65°C/W. These values are for PCB's with two and four layer boards with 0.5 oz copper, with two to four thermal vias from GND pin to bottom layer.

Here is a good rule of thumb for typical thermal impedances, and an ambient temperature maximum of 75°C: If your design requires that you dissipate more than 400mW internal to the LM3410, or there is 750mW of total power loss in the application, it is recommended that you use the 6-pin WSON or the 8-pin MSOP-PowerPad package with the exposed DAP.

SEPIC Converter

The LM3410 can easily be converted into a SEPIC converter. A SEPIC converter has the ability to regulate an output voltage that is either larger or smaller in magnitude than the input voltage. Other converters have this ability as well (CUK and Buck-Boost), but usually create an output voltage that is opposite in polarity to the input voltage. This topology is a perfect fit for Lithium Ion battery applications where the input voltage for a single cell Li-Ion battery will vary between 2.7V and 4.5V and the output voltage is somewhere in between. Most of the analysis of the LM3410 Boost Converter is applicable to the LM3410 SEPIC Converter.

SEPIC Design Guide:

SEPIC Conversion ratio without loss elements:

$$\frac{V_{OUT}}{V_{IN}} = \frac{D}{D'} \tag{56}$$

Therefore:

$$D = \frac{V_{OUT}}{V_{OUT} + V_{IN}} \tag{57}$$

Small ripple approximation:

In a well-designed SEPIC converter, the output voltage, and input voltage ripple, the inductor ripple I_{L1} and I_{L2} is small in comparison to the DC magnitude. Therefore it is a safe approximation to assume a DC value for these components. The main objective of the Steady State Analysis is to determine the steady state duty-cycle, voltage and current stresses on all components, and proper values for all components.

In a steady-state converter, the net volt-seconds across an inductor after one cycle will equal zero. Also, the charge into a capacitor will equal the charge out of a capacitor in one cycle.

Therefore:

$$I_{L2} = \left(\frac{D'}{D} \right) \times I_{L1}$$

and

$$I_{L1} = \left(\frac{D}{D'} \right) \times I_{LED}$$

(58)

Substituting I_{L1} into I_{L2}

$$I_{L2} = I_{LED}$$

(59)

The average inductor current of L2 is the average output load.

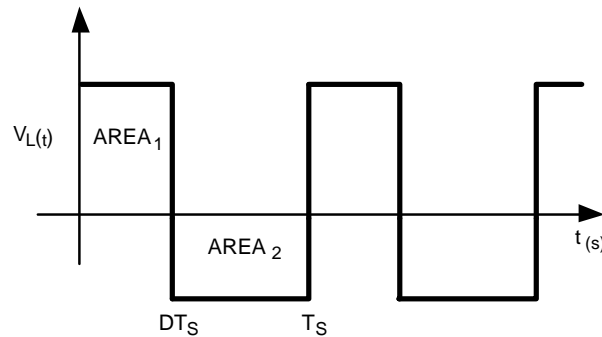
**Figure 25. Inductor Volt-Sec Balance Waveform**

Applying Charge balance on C1:

$$V_{C3} = \frac{D'(V_{OUT})}{D} \tag{60}$$

Since there are no DC voltages across either inductor, and capacitor C3 is connected to V_{IN} through L1 at one end, or to ground through L2 on the other end, we can say that

$$V_{C3} = V_{IN} \tag{61}$$

Therefore:

$$V_{IN} = \frac{D'(V_{OUT})}{D} \tag{62}$$

This verifies the original conversion ratio equation.

It is important to remember that the internal switch current is equal to I_{L1} and I_{L2} during the D interval. Design the converter so that the minimum ensured peak switch current limit (2.1A) is not exceeded.

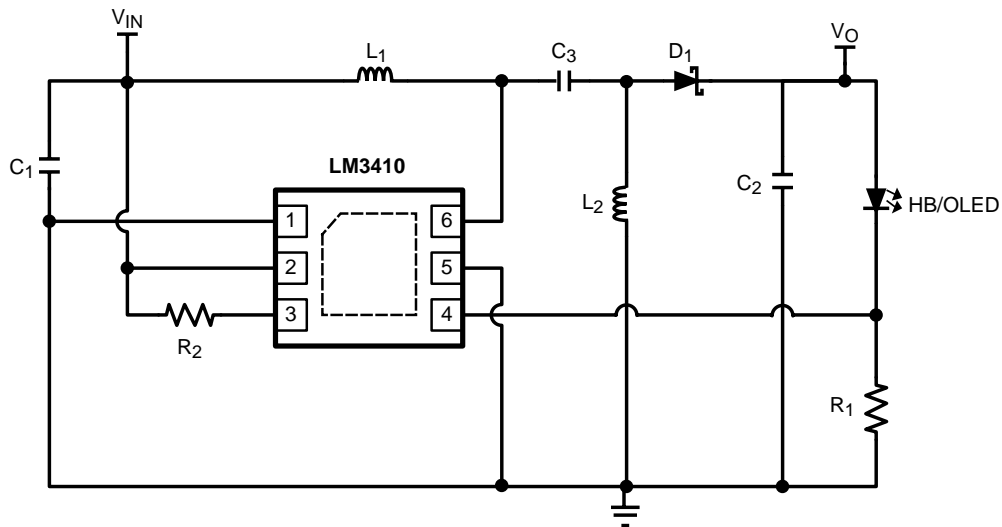

Figure 26. HB/OLED SEPIC CONVERTER Schematic

Steady State Analysis with Loss Elements

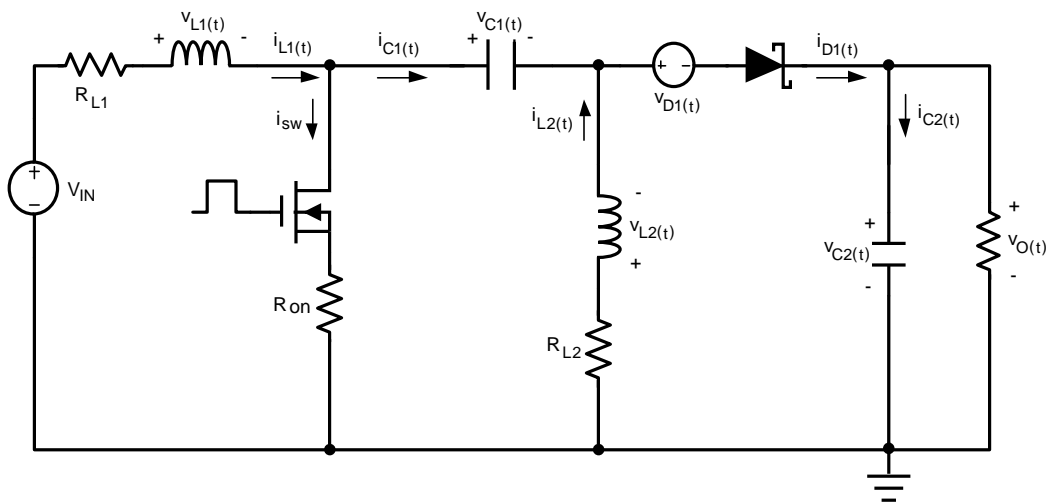

Figure 27. SEPIC Simplified Schematic

Using inductor volt-second balance and capacitor charge balance, the following equations are derived:

$$I_{L2} = (I_{LED}) \tag{63}$$

and

$$I_{L1} = (I_{LED}) \times (D/D') \tag{64}$$

$$\frac{V_{OUT}}{V_{IN}} = \left(\frac{D}{D'} \right) \left(\frac{1}{\left(1 + \frac{V_D}{V_{OUT}} + \frac{R_{L2}}{R} \right) + \left(\frac{D}{D'} \right) \left(\frac{R_{ON}}{R} \right) + \left(\frac{D^2}{D'^2} \right) \left(\frac{R_{L1}}{R} \right)} \right) \tag{65}$$

$$R_{OUT} = \frac{V_{OUT}}{I_{LED}} \tag{66}$$

Therefore:

$$\eta = \left(\frac{1}{\left(1 + \frac{V_D}{V_{OUT}} + \frac{R_{L2}}{R_{OUT}} \right) + \left(\frac{D}{D'^2} \right) \left(\frac{R_{ON}}{R_{OUT}} \right) + \left(\frac{D^2}{D'^2} \right) \left(\frac{R_{L1}}{R_{OUT}} \right)} \right) \tag{67}$$

One can see that all variables are known except for the duty cycle (D). A quadratic equation is needed to solve for D. A less accurate method of determining the duty cycle is to assume efficiency, and calculate the duty cycle.

$$\frac{V_{OUT}}{V_{IN}} = \left(\frac{D}{1 - D} \right) \times \eta \tag{68}$$

$$D = \left(\frac{V_{OUT}}{(V_{IN} \times \eta) + V_{OUT}} \right) \tag{69}$$

Table 7. Efficiencies for Typical SEPIC Applications

V_{IN}	2.7V	V_{IN}	3.3V	V_{IN}	5V
V_{OUT}	3.1V	V_{OUT}	3.1V	V_{OUT}	3.1V
I_{IN}	770mA	I_{IN}	600mA	I_{IN}	375mA
I_{LED}	500mA	I_{LED}	500mA	I_{LED}	500mA
η	75%	η	80%	η	83%

SEPIC Converter PCB Layout

The layout guidelines described for the LM3410 Boost-Converter are applicable to the SEPIC OLED Converter. [Figure 28](#) is a proper PCB layout for a SEPIC Converter.

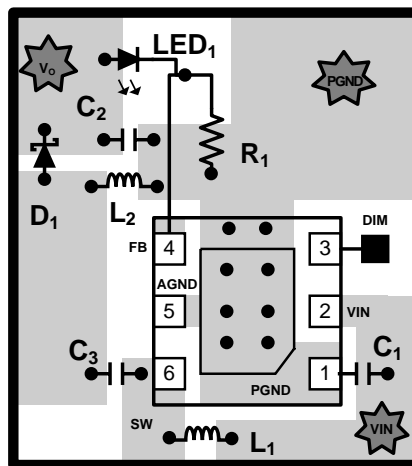

Figure 28. HB/OLED SEPIC PCB Layout

LM3410X SOT-23 Design Example 1: 5 x 1206 Series LED String Application

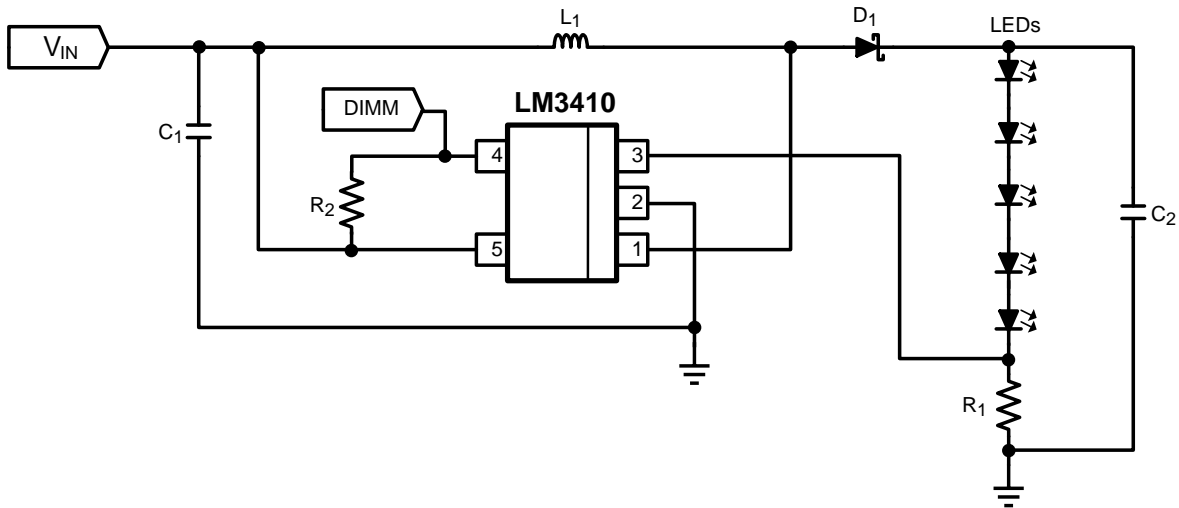

Figure 29. LM3410X (1.6MHz): $V_{IN} = 2.7V$ to $5.5V$, 5 x 3.3V LEDs, ($V_{OUT} \approx 16.5V$) $I_{LED} \approx 50mA$

Part ID	Part Value	Manufacturer	Part Number
U1	2.8A I_{SW} LED Driver	TI	LM3410XMF
C1, Input Cap	10 μ F, 6.3V, X5R	TDK	C2012X5R0J106M
C2 Output Cap	2.2 μ F, 25V, X5R	TDK	C2012X5R1E225M
D1, Catch Diode	0.4V _f Schottky 500mA, 30V _R	Diodes Inc	MBR0530
L1	10 μ H 1.2A	Coilcraft	DO1608C-103
R1	4.02 Ω , 1%	Vishay	CRCW08054R02F
R2	100k Ω , 1%	Vishay	CRCW08051003F
LED's	SMD-1206, 50mA, V _f \approx 3.6V	Lite-On	LTW-150k

LM3410Y SOT-23 Design Example 2: 5 x 1206 Series LED String Application

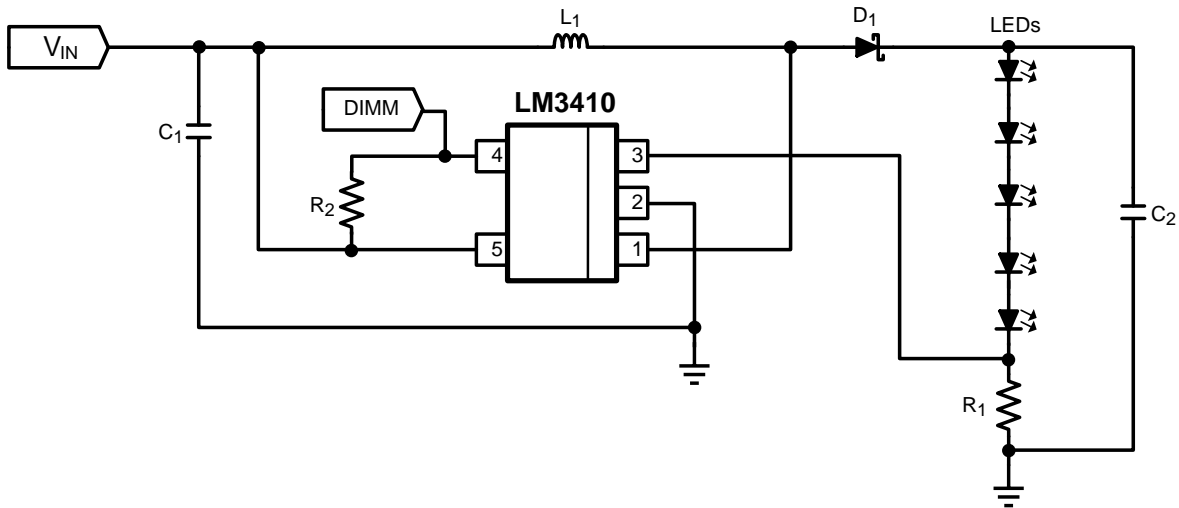

Figure 30. LM3410Y (525kHz): $V_{IN} = 2.7V$ to $5.5V$, 5 x 3.3V LEDs, ($V_{OUT} \approx 16.5V$) $I_{LED} \approx 50mA$

Part ID	Part Value	Manufacturer	Part Number
U1	2.8A I_{SW} LED Driver	TI	LM3410YMF
C1, Input Cap	10 μ F, 6.3V, X5R	TDK	C2012X5R0J106M
C2 Output Cap	2.2 μ F, 25V, X5R	TDK	C2012X5R1E225M
D1, Catch Diode	0.4V _f Schottky 500mA, 30V _R	Diodes Inc	MBR0530
L1	15 μ H 1.2A	Coilcraft	DO1608C-153
R1	4.02 Ω , 1%	Vishay	CRCW08054R02F
R2	100k Ω , 1%	Vishay	CRCW08051003F
LED's	SMD-1206, 50mA, V _f \approx 3.6V	Lite-On	LTW-150k

LM3410X WSON Design Example 3: 7 LEDs x 5 LED String Backlighting Application

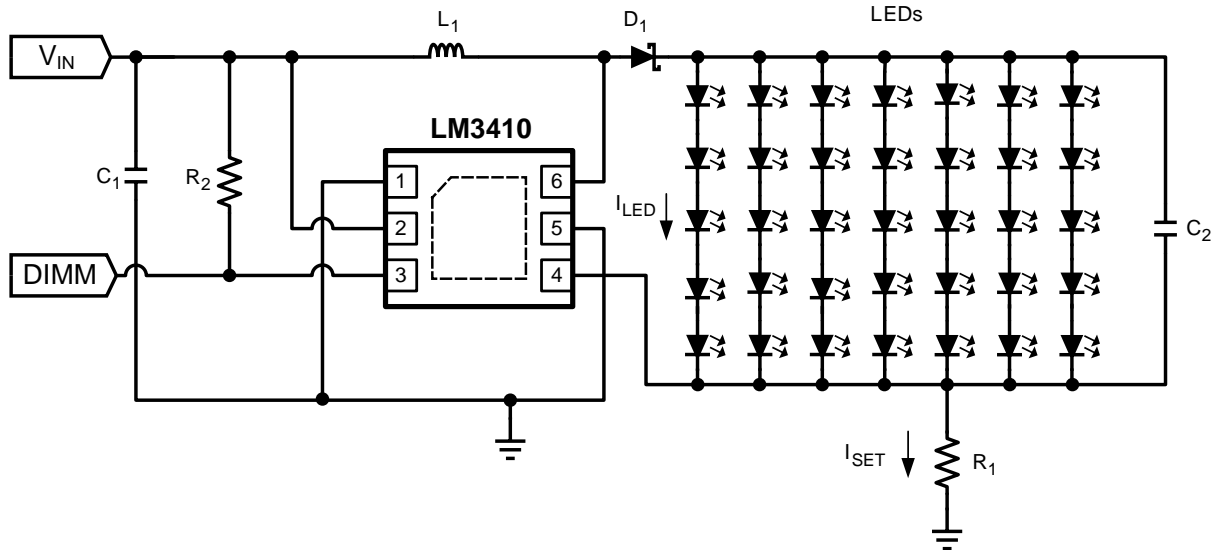

Figure 31. LM3410X (1.6MHz): $V_{IN} = 2.7V$ to $5.5V$, $7 \times 5 \times 3.3V$ LEDs, ($V_{OUT} \approx 16.7V$), $I_{LED} \approx 25mA$

Part ID	Part Value	Manufacturer	Part Number
U1	2.8A I_{SW} LED Driver	TI	LM3410XSD
C1, Input Cap	10 μ F, 6.3V, X5R	TDK	C2012X5R0J106M
C2 Output Cap	4.7 μ F, 25V, X5R	TDK	C2012X5R1E475M
D1, Catch Diode	0.4V _f Schottky 500mA, 30V _R	Diodes Inc	MBR0530
L1	8.2 μ H, 2A	Coilcraft	MSS6132-822ML
R1	1.15 Ω , 1%	Vishay	CRCW08051R15F
R2	100k Ω , 1%	Vishay	CRCW08051003F
LED's	SMD-1206, 50mA, V _f \approx 3.6V	Lite-On	LTW-150k

LM3410X WSON Design Example 4: 3 x HB LED String Application

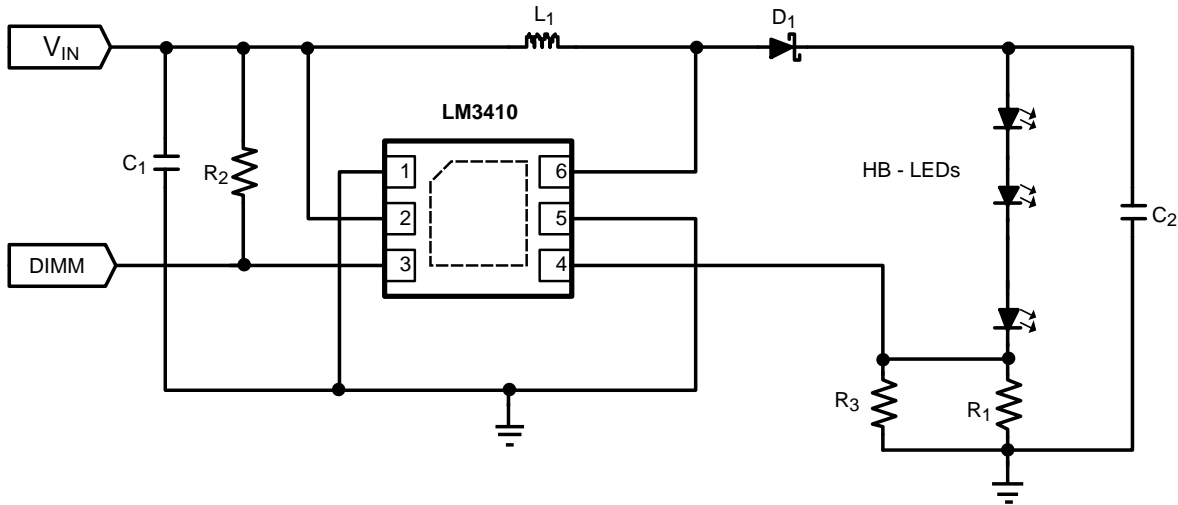

Figure 32. LM3410X (1.6MHz): $V_{IN} = 2.7V$ to $5.5V$, 3 x 3.4V LEDs, ($V_{OUT} \approx 11V$) $I_{LED} \approx 340mA$

Part ID	Part Value	Manufacturer	Part Number
U1	2.8A I_{SW} LED Driver	TI	LM3410XSD
C1, Input Cap	10 μ F, 6.3V, X5R	TDK	C2012X5R0J106M
C2 Output Cap	2.2 μ F, 25V, X5R	TDK	C2012X5R1E225M
D1, Catch Diode	0.4V _f Schottky 500mA, 30V _R	Diodes Inc	MBR0530
L1	10 μ H 1.2A	Coilcraft	DO1608C-103
R1	1.00 Ω , 1%	Vishay	CRCW08051R00F
R2	100k Ω , 1%	Vishay	CRCW08051003F
R3	1.50 Ω , 1%	Vishay	CRCW08051R50F
HB - LED's	340mA, $V_f \approx 3.6V$	CREE	XREWHT-L1-0000-0901

LM3410Y SOT-23 Design Example 5: 5 x 1206 Series LED String Application with OVP

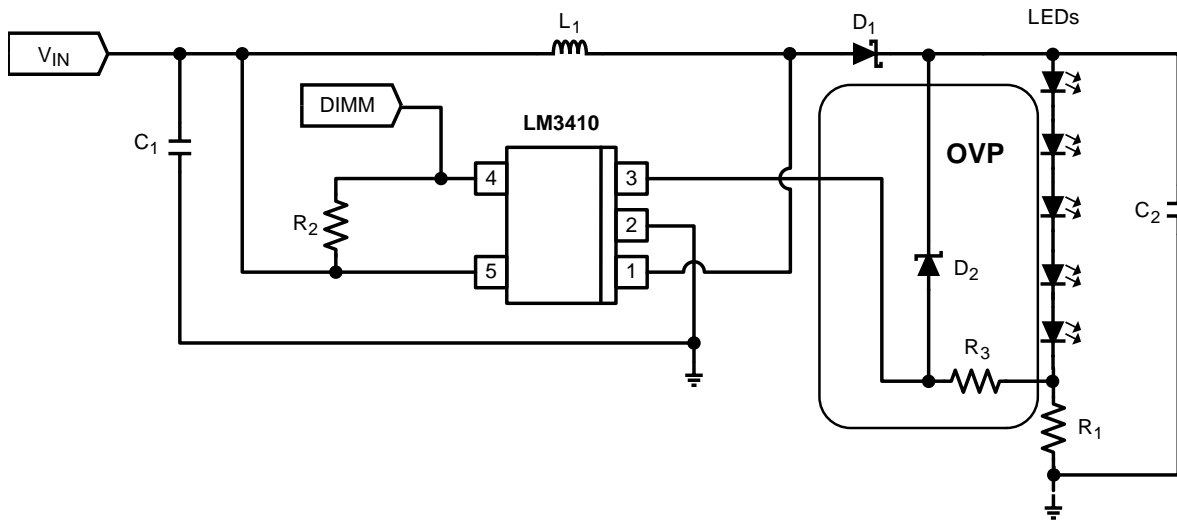

Figure 33. LM3410Y (525kHz): $V_{IN} = 2.7V$ to $5.5V$, 5 x 3.3V LEDs, ($V_{OUT} \approx 16.5V$) $I_{LED} \approx 50mA$

Part ID	Part Value	Manufacturer	Part Number
U1	2.8A I_{SW} LED Driver	TI	LM3410YMF
C1 Input Cap	10 μ F, 6.3V, X5R	TDK	C2012X5R0J106M
C2 Output Cap	2.2 μ F, 25V, X5R	TDK	C2012X5R1E225M
D1, Catch Diode	0.4V _f Schottky 500mA,	Diodes Inc	MBR0530
D2	18V Zener diode	Diodes Inc	1N4746A
L1	15 μ H, 0.70A	TDK	VLS4012T-150MR65
R1	4.02 Ω , 1%	Vishay	CRCW08054R02F
R2	100k Ω , 1%	Vishay	CRCW08051003F
R3	100 Ω , 1%	Vishay	CRCW06031000F
LED's	SMD-1206, 50mA, $V_f \approx 3.6V$	Lite-On	LTW-150k

LM3410X SEPIC WSON Design Example 6: HB/OLED Illumination Application

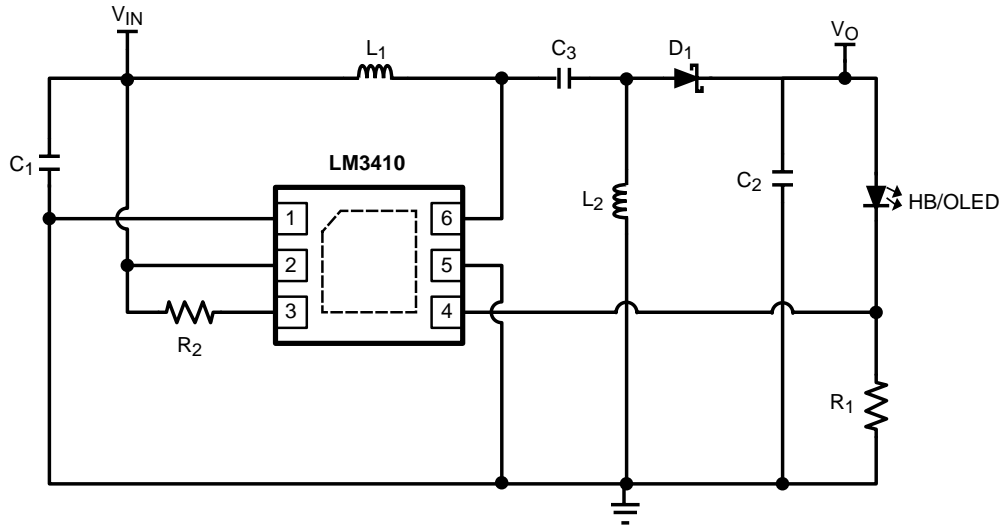

Figure 34. LM3410X (1.6MHz): $V_{IN} = 2.7V$ to $5.5V$, ($V_{OUT} \approx 3.8V$) $I_{LED} \approx 300mA$

Part ID	Part Value	Manufacturer	Part Number
U1	2.8A I_{SW} LED Driver	TI	LM3410XSD
C1 Input Cap	10 μ F, 6.3V, X5R	TDK	C2012X5R0J106K
C2 Output Cap	10 μ F, 6.3V, X5R	TDK	C2012X5R0J106K
C3 Cap	2.2 μ F, 25V, X5R	TDK	C2012X5R1E225M
D1, Catch Diode	0.4V _f , Schottky 1A, 20V _R	Diodes Inc	DFLS120L
L1 and L2	4.7 μ H 3A	Coilcraft	MSS6132-472
R1	665 m Ω , 1%	Vishay	CRCW0805R665F
R2	100k Ω , 1%	Vishay	CRCW08051003F
HB - LED's	350mA, $V_f \approx 3.6V$	CREE	XREWHT-L1-0000-0901

LM3410X WSON Design Example 7: Boost Flash Application

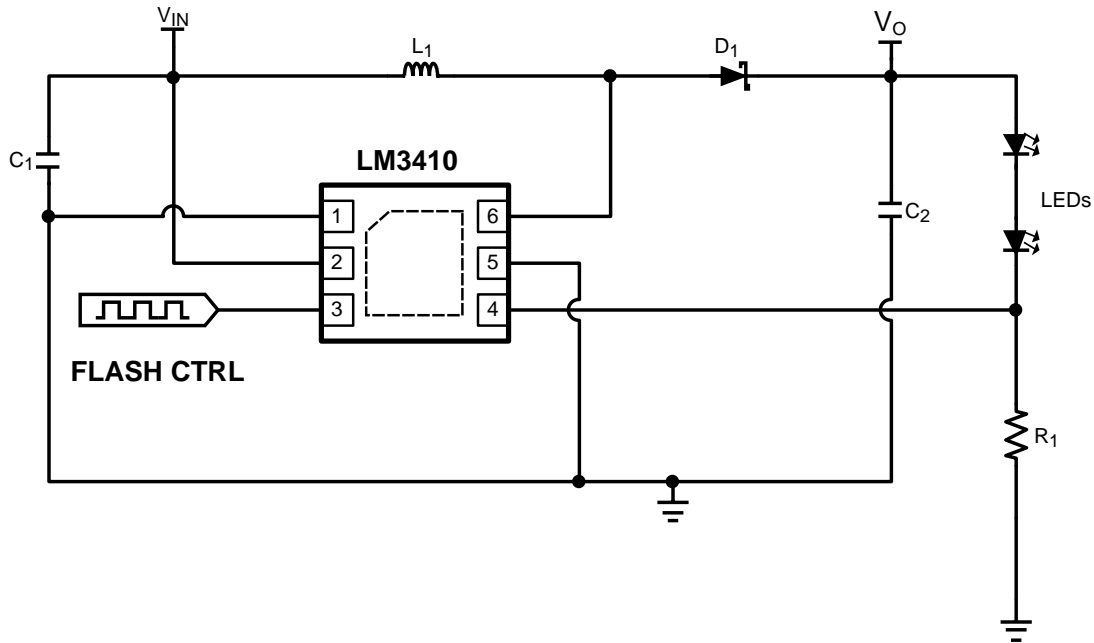
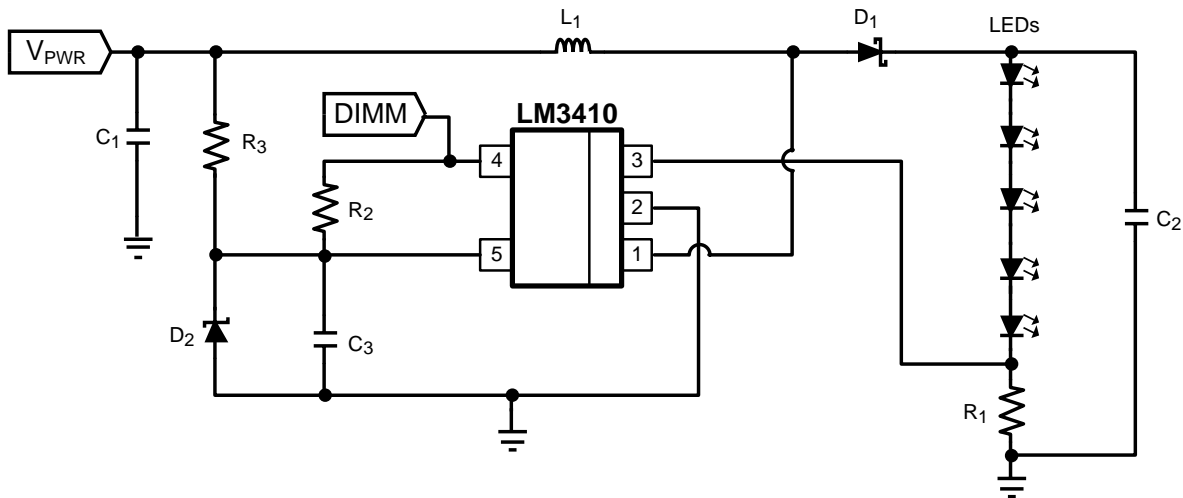

Figure 35. LM3410X (1.6MHz): $V_{IN} = 2.7V$ to $5.5V$, ($V_{OUT} \approx 8V$) $I_{LED} \approx 1.0A$ Pulsed

Part ID	Part Value	Manufacturer	Part Number
U1	2.8A I_{SW} LED Driver	TI	LM3410XSD
C1 Input Cap	10 μ F, 6.3V, X5R	TDK	C2012X5R0J106M
C2 Output Cap	10 μ F, 16V, X5R	TDK	C2012X5R1A106M
D1, Catch Diode	0.4V _f Schottky 500mA, 30V _R	Diodes Inc	MBR0530
L1	4.7 μ H, 3A	Coilcraft	MSS6132-472
R1	200m Ω , 1%	Vishay	CRCW0805R200F
LED's	500mA, $V_f \approx 3.6V$, $I_{PULSE} = 1.0A$	CREE	XREWHT-L1-0000-0901

LM3410X SOT-23 Design Example 8: 5 x 1206 Series LED String Application with $V_{IN} > 5.5V$

Figure 36. LM3410X (1.6MHz): $V_{PWR} = 9V$ to $14V$, ($V_{OUT} \approx 16.5V$) $I_{LED} \approx 50mA$

Part ID	Part Value	Mfg	Part Number
U1	2.8A I_{SW} LED Driver	TI	LM3410XMF
C1 Input V_{PWR} Cap	10 μ F, 6.3V, X5R	TDK	C2012X5R0J106M
C2 Output Cap	2.2 μ F, 25V, X5R	TDK	C2012X5R1E225M
C2 Input V_{IN} Cap	0.1 μ F, 6.3V, X5R	TDK	C1005X5R1C104K
D1, Catch Diode	0.43V _f , Schotky, 0.5A, 30V _R	Diodes Inc	MBR0530
L1	10 μ H 1.2A	Coilcraft	DO1608C-103
R1	4.02 Ω , 1%	Vishay	CRCW08054R02F
R2	100k Ω , 1%	Vishay	CRCW08051003F
R3	576 Ω , 1%	Vishay	CRCW08055760F
D2	3.3V Zener, SOT-23	Diodes Inc	BZX84C3V3
LED's	SMD-1206, 50mA, $V_f \approx 3.6V$	Lite-On	LTW-150k

LM3410X WSON Design Example 9: Camera Flash or Strobe Circuit Application

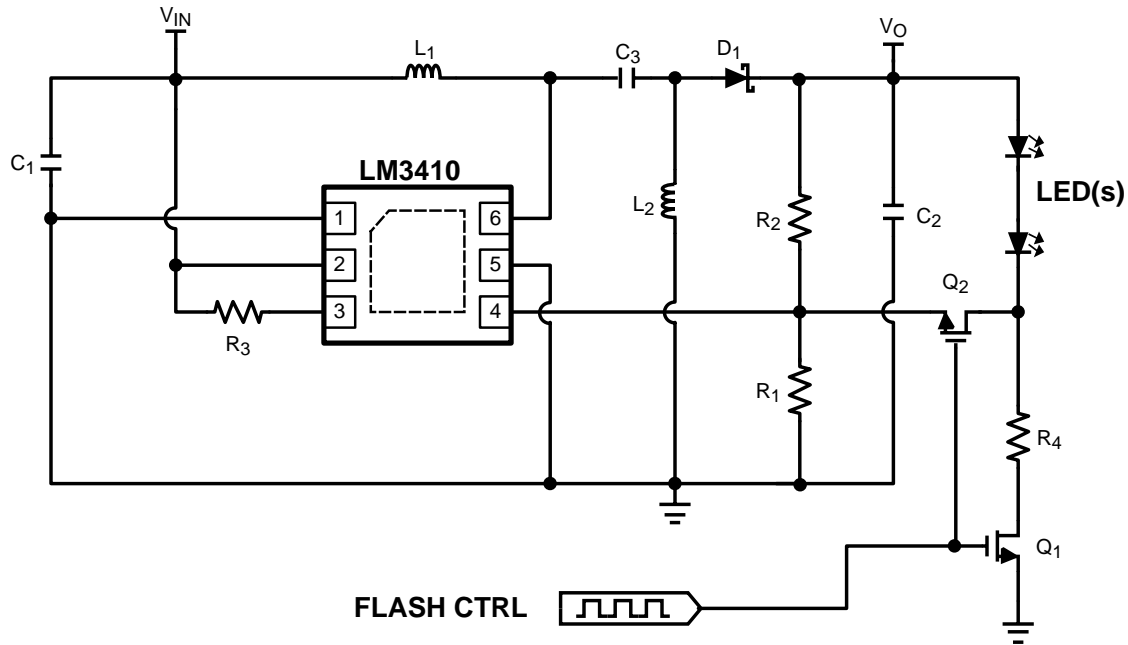

Figure 37. LM3410X (1.6MHz): $V_{IN} = 2.7V$ to 5.5 , ($V_{OUT} \approx 7.5V$), $I_{LED} \approx 1.5A$ Flash

Part ID	Part Value	Mfg	Part Number
U1	2.8A I_{SW} LED Driver	TI	LM3410XSD
C1 Input V_{PWR} Cap	10 μ F, 6.3V, X5R	TDK	C1608X5R0J106K
C2 Output Cap	220 μ F, 10V, Tanatalum	KEMET	T491V2271010A2
C3 Cap	10 μ F, 16V, X5R	TDK	C3216X5R0J106K
D1, Catch Diode	0.43V _f , Schotky, 1.0A, 20V _R	Diodes Inc	DFLS120L
L1	3.3 μ H 2.7A	Coilcraft	MOS6020-332
R1	1.0k Ω , 1%	Vishay	CRCW08051001F
R2	37.4k Ω , 1%	Vishay	CRCW08053742F
R3	100k Ω , 1%	Vishay	CRCW08051003F
R4	0.15 Ω , 1%	Vishay	CRCW0805R150F
Q1, Q2	30V, $I_D = 3.9A$	ZETEX	ZXMN3A14F
LED's	500mA, $V_f \approx 3.6V$, $I_{PULSE} = 1.5A$	CREE	XREWHT-L1-0000-00901

LM3410X SOT-23 Design Example 10: 5 x 1206 Series LED String Application with V_{IN} and V_{PWR} Rail > 5.5V

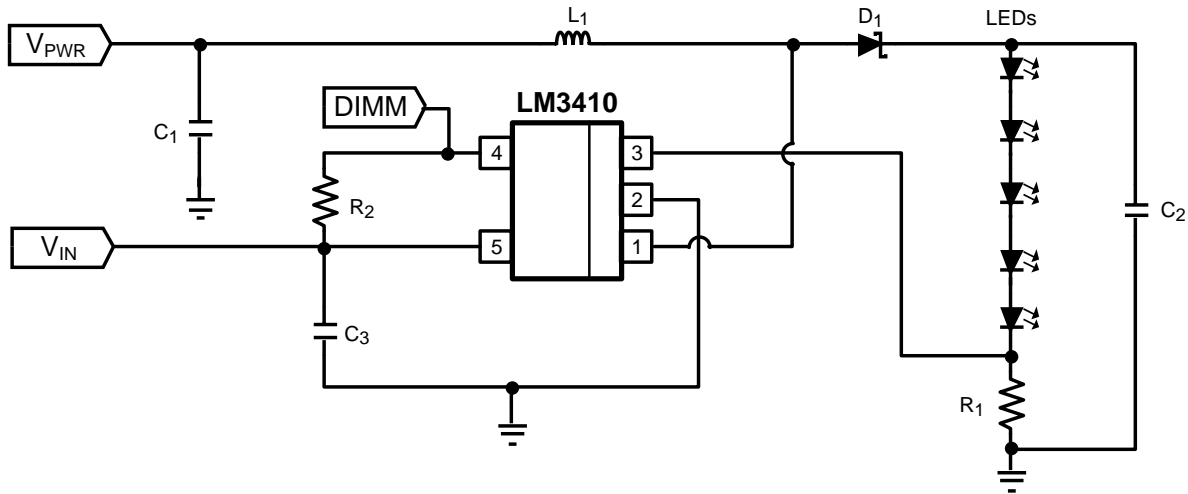

Figure 38. LM3410X (1.6MHz): $V_{PWR} = 9V$ to $14V$, $V_{IN} = 2.7V$ to $5.5V$, ($V_{OUT} \approx 16.5V$) $I_{LED} \approx 50mA$

Part ID	Part Value	Mfg	Part Number
U1	2.8A I_{SW} LED Driver	TI	LM3410XMF
C1 Input V_{PWR} Cap	10µF, 6.3V, X5R	TDK	C2012X5R0J106M
C2 V_{OUT} Cap	2.2µF, 25V, X5R	TDK	C2012X5R1E225M
C3 Input V_{IN} Cap	0.1µF, 6.3V, X5R	TDK	C1005X5R1C104K
D1, Catch Diode	0.43V _f , Schotky, 0.5A, 30V _R	Diodes Inc	MBR0530
L1	10µH 1.5A	Coilcraft	DO1608C-103
R1	4.02Ω, 1%	Vishay	CRCW08054R02F
R2	100kΩ, 1%	Vishay	CRCW08051003F
LED's	SMD-1206, 50mA, $V_f \approx 3.6V$	Lite-On	LTW-150k

LM3410X WSON Design Example 11: Boot-Strap Circuit to Extend Battery Life

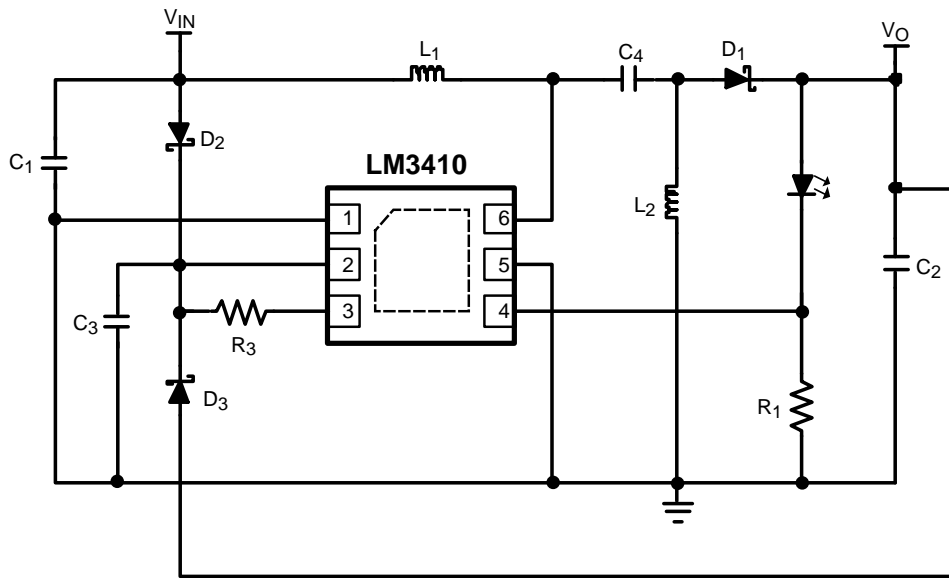

Figure 39. LM3410X (1.6MHz): $V_{IN} = 1.9V$ to $5.5V$, $V_{IN} > 2.3V$ (TYP) for Startup, $I_{LED} \approx 300mA$

Part ID	Part Value	Mfg	Part Number
U1	2.8A I_{SW} LED Driver	TI	LM3410XSD
C1 Input V_{PWR} Cap	10 μ F, 6.3V, X5R	TDK	C1608X5R0J106K
C2 V_{OUT} Cap	10 μ F, 6.3V, X5R	TDK	C1608X5R0J106K
C3 Input V_{IN} Cap	0.1 μ F, 6.3V, X5R	TDK	C1005X5R1C104K
D1, Catch Diode	0.43V _f , Schotky, 1.0A, 20V _R	Diodes Inc	DFLS120L
D2, D3	Dual Small Signal Schotky	Diodes Inc	BAT54CT
L1, L2	3.3 μ H 3A	Coilcraft	MOS6020-332
R1	665 m Ω , 1%	Vishay	CRCW0805R665F
R3	100k Ω , 1%	Vishay	CRCW08051003F
HB/OLED	3.4V _f , 350mA	TT Electronics/Optek	OVSPWBCR44

REVISION HISTORY

Changes from Revision F (May 2013) to Revision G	Page
• Changed layout of National Data Sheet to TI format	37

PACKAGING INFORMATION

Orderable Device	Status (1)	Package Type	Package Drawing	Pins	Package Qty	Eco Plan (2)	Lead/Ball Finish	MSL Peak Temp (3)	Op Temp (°C)	Top-Side Markings (4)	Samples
LM3410XMF/NOPB	ACTIVE	SOT-23	DBV	5	1000	Green (RoHS & no Sb/Br)	CU SN	Level-1-260C-UNLIM	-40 to 125	SSVB	Samples
LM3410XMFE/NOPB	ACTIVE	SOT-23	DBV	5	250	Green (RoHS & no Sb/Br)	CU SN	Level-1-260C-UNLIM	-40 to 125	SSVB	Samples
LM3410XMF/NOPB	ACTIVE	SOT-23	DBV	5	3000	Green (RoHS & no Sb/Br)	CU SN	Level-1-260C-UNLIM	-40 to 125	SSVB	Samples
LM3410XMY/NOPB	ACTIVE	MSOP- PowerPAD	DGN	8	1000	Green (RoHS & no Sb/Br)	CU SN	Level-1-260C-UNLIM	-40 to 125	SSXB	Samples
LM3410XMYE/NOPB	ACTIVE	MSOP- PowerPAD	DGN	8	250	Green (RoHS & no Sb/Br)	CU SN	Level-1-260C-UNLIM	-40 to 125	SSXB	Samples
LM3410XMYX/NOPB	ACTIVE	MSOP- PowerPAD	DGN	8	3500	Green (RoHS & no Sb/Br)	CU SN	Level-1-260C-UNLIM	-40 to 125	SSXB	Samples
LM3410XQMF/NOPB	ACTIVE	SOT-23	DBV	5	1000	Green (RoHS & no Sb/Br)	CU SN	Level-1-260C-UNLIM	-40 to 125	SXUB	Samples
LM3410XQMF/NOPB	ACTIVE	SOT-23	DBV	5	3000	Green (RoHS & no Sb/Br)	CU SN	Level-1-260C-UNLIM	-40 to 125	SXUB	Samples
LM3410XSD/NOPB	ACTIVE	WSON	NGG	6	1000	Green (RoHS & no Sb/Br)	CU SN	Level-1-260C-UNLIM	-40 to 125	3410X	Samples
LM3410XSDE/NOPB	ACTIVE	WSON	NGG	6	250	Green (RoHS & no Sb/Br)	CU SN	Level-1-260C-UNLIM	-40 to 125	3410X	Samples
LM3410XSDX/NOPB	ACTIVE	WSON	NGG	6	4500	Green (RoHS & no Sb/Br)	CU SN	Level-1-260C-UNLIM	-40 to 125	3410X	Samples
LM3410YMF/NOPB	ACTIVE	SOT-23	DBV	5	1000	Green (RoHS & no Sb/Br)	CU SN	Level-1-260C-UNLIM	-40 to 125	SSZB	Samples
LM3410YMFE/NOPB	ACTIVE	SOT-23	DBV	5	250	Green (RoHS & no Sb/Br)	CU SN	Level-1-260C-UNLIM	-40 to 125	SSZB	Samples
LM3410YMF/NOPB	ACTIVE	SOT-23	DBV	5	3000	Green (RoHS & no Sb/Br)	CU SN	Level-1-260C-UNLIM	-40 to 125	SSZB	Samples
LM3410YMY/NOPB	ACTIVE	MSOP- PowerPAD	DGN	8	1000	Green (RoHS & no Sb/Br)	CU SN	Level-1-260C-UNLIM	-40 to 125	STAB	Samples
LM3410YMYE/NOPB	ACTIVE	MSOP- PowerPAD	DGN	8	250	Green (RoHS & no Sb/Br)	CU SN	Level-1-260C-UNLIM	-40 to 125	STAB	Samples
LM3410YMYX/NOPB	ACTIVE	MSOP- PowerPAD	DGN	8	3500	Green (RoHS & no Sb/Br)	CU SN	Level-1-260C-UNLIM	-40 to 125	STAB	Samples

Orderable Device	Status (1)	Package Type	Package Drawing	Pins	Package Qty	Eco Plan (2)	Lead/Ball Finish	MSL Peak Temp (3)	Op Temp (°C)	Top-Side Markings (4)	Samples
LM3410YQMF/NOPB	ACTIVE	SOT-23	DBV	5	1000	Green (RoHS & no Sb/Br)	CU SN	Level-1-260C-UNLIM	-40 to 125	SXXB	Samples
LM3410YQMF/NOPB	ACTIVE	SOT-23	DBV	5	3000	Green (RoHS & no Sb/Br)	CU SN	Level-1-260C-UNLIM	-40 to 125	SXXB	Samples
LM3410YSD/NOPB	ACTIVE	WSON	NGG	6	1000	Green (RoHS & no Sb/Br)	CU SN	Level-1-260C-UNLIM	-40 to 125	3410Y	Samples
LM3410YSDE/NOPB	ACTIVE	WSON	NGG	6	250	Green (RoHS & no Sb/Br)	CU SN	Level-1-260C-UNLIM	-40 to 125	3410Y	Samples
LM3410YSDX/NOPB	ACTIVE	WSON	NGG	6	4500	Green (RoHS & no Sb/Br)	CU SN	Level-1-260C-UNLIM	-40 to 125	3410Y	Samples

(1) The marketing status values are defined as follows:

ACTIVE: Product device recommended for new designs.

LIFEBUY: TI has announced that the device will be discontinued, and a lifetime-buy period is in effect.

NRND: Not recommended for new designs. Device is in production to support existing customers, but TI does not recommend using this part in a new design.

PREVIEW: Device has been announced but is not in production. Samples may or may not be available.

OBSELETE: TI has discontinued the production of the device.

(2) Eco Plan - The planned eco-friendly classification: Pb-Free (RoHS), Pb-Free (RoHS Exempt), or Green (RoHS & no Sb/Br) - please check <http://www.ti.com/productcontent> for the latest availability information and additional product content details.

TBD: The Pb-Free/Green conversion plan has not been defined.

Pb-Free (RoHS): TI's terms "Lead-Free" or "Pb-Free" mean semiconductor products that are compatible with the current RoHS requirements for all 6 substances, including the requirement that lead not exceed 0.1% by weight in homogeneous materials. Where designed to be soldered at high temperatures, TI Pb-Free products are suitable for use in specified lead-free processes.

Pb-Free (RoHS Exempt): This component has a RoHS exemption for either 1) lead-based flip-chip solder bumps used between the die and package, or 2) lead-based die adhesive used between the die and leadframe. The component is otherwise considered Pb-Free (RoHS compatible) as defined above.

Green (RoHS & no Sb/Br): TI defines "Green" to mean Pb-Free (RoHS compatible), and free of Bromine (Br) and Antimony (Sb) based flame retardants (Br or Sb do not exceed 0.1% by weight in homogeneous material)

(3) MSL, Peak Temp. -- The Moisture Sensitivity Level rating according to the JEDEC industry standard classifications, and peak solder temperature.

(4) Multiple Top-Side Markings will be inside parentheses. Only one Top-Side Marking contained in parentheses and separated by a "~" will appear on a device. If a line is indented then it is a continuation of the previous line and the two combined represent the entire Top-Side Marking for that device.

Important Information and Disclaimer: The information provided on this page represents TI's knowledge and belief as of the date that it is provided. TI bases its knowledge and belief on information provided by third parties, and makes no representation or warranty as to the accuracy of such information. Efforts are underway to better integrate information from third parties. TI has taken and continues to take reasonable steps to provide representative and accurate information but may not have conducted destructive testing or chemical analysis on incoming materials and chemicals. TI and TI suppliers consider certain information to be proprietary, and thus CAS numbers and other limited information may not be available for release.

In no event shall TI's liability arising out of such information exceed the total purchase price of the TI part(s) at issue in this document sold by TI to Customer on an annual basis.

OTHER QUALIFIED VERSIONS OF LM3410, LM3410-Q1 :

- Catalog: [LM3410](#)
- Automotive: [LM3410-Q1](#)

NOTE: Qualified Version Definitions:

- Catalog - TI's standard catalog product
- Automotive - Q100 devices qualified for high-reliability automotive applications targeting zero defects

TAPE AND REEL INFORMATION

QUADRANT ASSIGNMENTS FOR PIN 1 ORIENTATION IN TAPE

*All dimensions are nominal

Device	Package Type	Package Drawing	Pins	SPQ	Reel Diameter (mm)	Reel Width W1 (mm)	A0 (mm)	B0 (mm)	K0 (mm)	P1 (mm)	W (mm)	Pin1 Quadrant
LM3410XMF/NOPB	SOT-23	DBV	5	1000	178.0	8.4	3.2	3.2	1.4	4.0	8.0	Q3
LM3410XMF/NOPB	SOT-23	DBV	5	250	178.0	8.4	3.2	3.2	1.4	4.0	8.0	Q3
LM3410XMF/NOPB	SOT-23	DBV	5	3000	178.0	8.4	3.2	3.2	1.4	4.0	8.0	Q3
LM3410XMY/NOPB	MSOP-Power PAD	DGN	8	1000	178.0	12.4	5.3	3.4	1.4	8.0	12.0	Q1
LM3410XMY/NOPB	MSOP-Power PAD	DGN	8	250	178.0	12.4	5.3	3.4	1.4	8.0	12.0	Q1
LM3410XMY/NOPB	MSOP-Power PAD	DGN	8	3500	330.0	12.4	5.3	3.4	1.4	8.0	12.0	Q1
LM3410XQMF/NOPB	SOT-23	DBV	5	1000	178.0	8.4	3.2	3.2	1.4	4.0	8.0	Q3
LM3410XQMF/NOPB	SOT-23	DBV	5	3000	178.0	8.4	3.2	3.2	1.4	4.0	8.0	Q3
LM3410XSD/NOPB	WSON	NGG	6	1000	178.0	12.4	3.3	3.3	1.0	8.0	12.0	Q1
LM3410XSD/NOPB	WSON	NGG	6	250	178.0	12.4	3.3	3.3	1.0	8.0	12.0	Q1
LM3410XSD/NOPB	WSON	NGG	6	4500	330.0	12.4	3.3	3.3	1.0	8.0	12.0	Q1
LM3410YMF/NOPB	SOT-23	DBV	5	1000	178.0	8.4	3.2	3.2	1.4	4.0	8.0	Q3
LM3410YMF/NOPB	SOT-23	DBV	5	250	178.0	8.4	3.2	3.2	1.4	4.0	8.0	Q3
LM3410YMF/NOPB	SOT-23	DBV	5	3000	178.0	8.4	3.2	3.2	1.4	4.0	8.0	Q3

Device	Package Type	Package Drawing	Pins	SPQ	Reel Diameter (mm)	Reel Width W1 (mm)	A0 (mm)	B0 (mm)	K0 (mm)	P1 (mm)	W (mm)	Pin1 Quadrant
LM3410YMY/NOPB	MSOP-Power PAD	DGN	8	1000	178.0	12.4	5.3	3.4	1.4	8.0	12.0	Q1
LM3410YMYE/NOPB	MSOP-Power PAD	DGN	8	250	178.0	12.4	5.3	3.4	1.4	8.0	12.0	Q1
LM3410YMYX/NOPB	MSOP-Power PAD	DGN	8	3500	330.0	12.4	5.3	3.4	1.4	8.0	12.0	Q1
LM3410YQMF/NOPB	SOT-23	DBV	5	1000	178.0	8.4	3.2	3.2	1.4	4.0	8.0	Q3
LM3410YQMF/NOPB	SOT-23	DBV	5	3000	178.0	8.4	3.2	3.2	1.4	4.0	8.0	Q3
LM3410YSD/NOPB	WSON	NGG	6	1000	178.0	12.4	3.3	3.3	1.0	8.0	12.0	Q1
LM3410YSDE/NOPB	WSON	NGG	6	250	178.0	12.4	3.3	3.3	1.0	8.0	12.0	Q1
LM3410YSDX/NOPB	WSON	NGG	6	4500	330.0	12.4	3.3	3.3	1.0	8.0	12.0	Q1

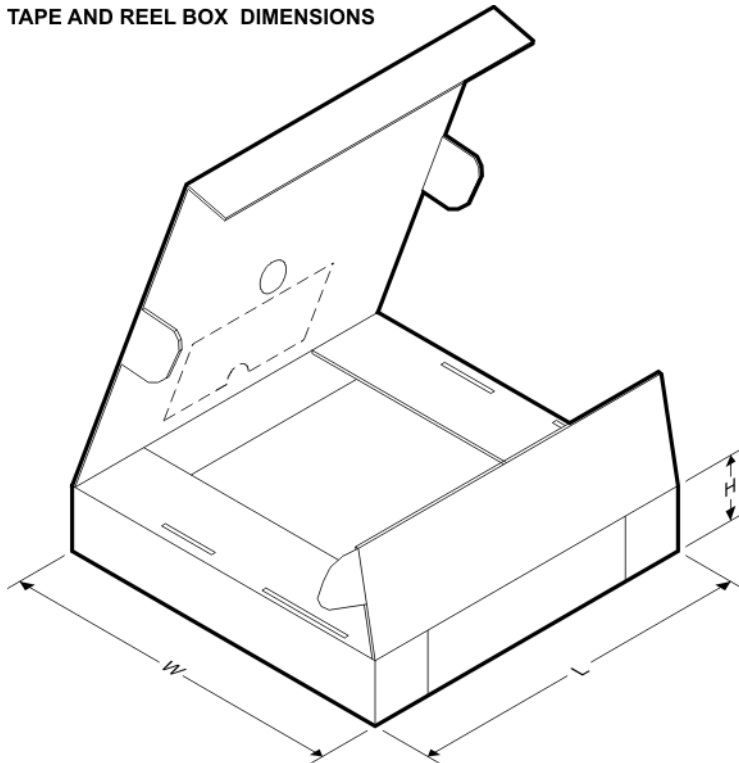
TAPE AND REEL BOX DIMENSIONS

*All dimensions are nominal

Device	Package Type	Package Drawing	Pins	SPQ	Length (mm)	Width (mm)	Height (mm)
LM3410XMF/NOPB	SOT-23	DBV	5	1000	210.0	185.0	35.0
LM3410XMF/NOPB	SOT-23	DBV	5	250	210.0	185.0	35.0
LM3410XMF/NOPB	SOT-23	DBV	5	3000	210.0	185.0	35.0
LM3410XMY/NOPB	MSOP-PowerPAD	DGN	8	1000	210.0	185.0	35.0
LM3410XMYE/NOPB	MSOP-PowerPAD	DGN	8	250	210.0	185.0	35.0

Device	Package Type	Package Drawing	Pins	SPQ	Length (mm)	Width (mm)	Height (mm)
LM3410XMYX/NOPB	MSOP-PowerPAD	DGN	8	3500	367.0	367.0	35.0
LM3410XQMF/NOPB	SOT-23	DBV	5	1000	210.0	185.0	35.0
LM3410XQMF/NOPB	SOT-23	DBV	5	3000	210.0	185.0	35.0
LM3410XSD/NOPB	WSON	NGG	6	1000	210.0	185.0	35.0
LM3410XSDE/NOPB	WSON	NGG	6	250	210.0	185.0	35.0
LM3410XSDX/NOPB	WSON	NGG	6	4500	367.0	367.0	35.0
LM3410YMF/NOPB	SOT-23	DBV	5	1000	210.0	185.0	35.0
LM3410YMF/NOPB	SOT-23	DBV	5	250	210.0	185.0	35.0
LM3410YMF/NOPB	SOT-23	DBV	5	3000	210.0	185.0	35.0
LM3410YMY/NOPB	MSOP-PowerPAD	DGN	8	1000	210.0	185.0	35.0
LM3410YMYE/NOPB	MSOP-PowerPAD	DGN	8	250	210.0	185.0	35.0
LM3410YMYX/NOPB	MSOP-PowerPAD	DGN	8	3500	367.0	367.0	35.0
LM3410YQMF/NOPB	SOT-23	DBV	5	1000	210.0	185.0	35.0
LM3410YQMF/NOPB	SOT-23	DBV	5	3000	210.0	185.0	35.0
LM3410YSD/NOPB	WSON	NGG	6	1000	210.0	185.0	35.0
LM3410YSDE/NOPB	WSON	NGG	6	250	210.0	185.0	35.0
LM3410YSDX/NOPB	WSON	NGG	6	4500	367.0	367.0	35.0

DBV (R-PDSO-G5)

PLASTIC SMALL-OUTLINE PACKAGE



- NOTES:
- A. All linear dimensions are in millimeters.
 - B. This drawing is subject to change without notice.
 - C. Body dimensions do not include mold flash or protrusion. Mold flash and protrusion shall not exceed 0.15 per side.
 - D. Falls within JEDEC MO-178 Variation AA.

DBV (R-PDSO-G5)

PLASTIC SMALL OUTLINE



- NOTES:
- A. All linear dimensions are in millimeters.
 - B. This drawing is subject to change without notice.
 - C. Customers should place a note on the circuit board fabrication drawing not to alter the center solder mask defined pad.
 - D. Publication IPC-7351 is recommended for alternate designs.
 - E. Laser cutting apertures with trapezoidal walls and also rounding corners will offer better paste release. Customers should contact their board assembly site for stencil design recommendations. Example stencil design based on a 50% volumetric metal load solder paste. Refer to IPC-7525 for other stencil recommendations.

DGN0008A

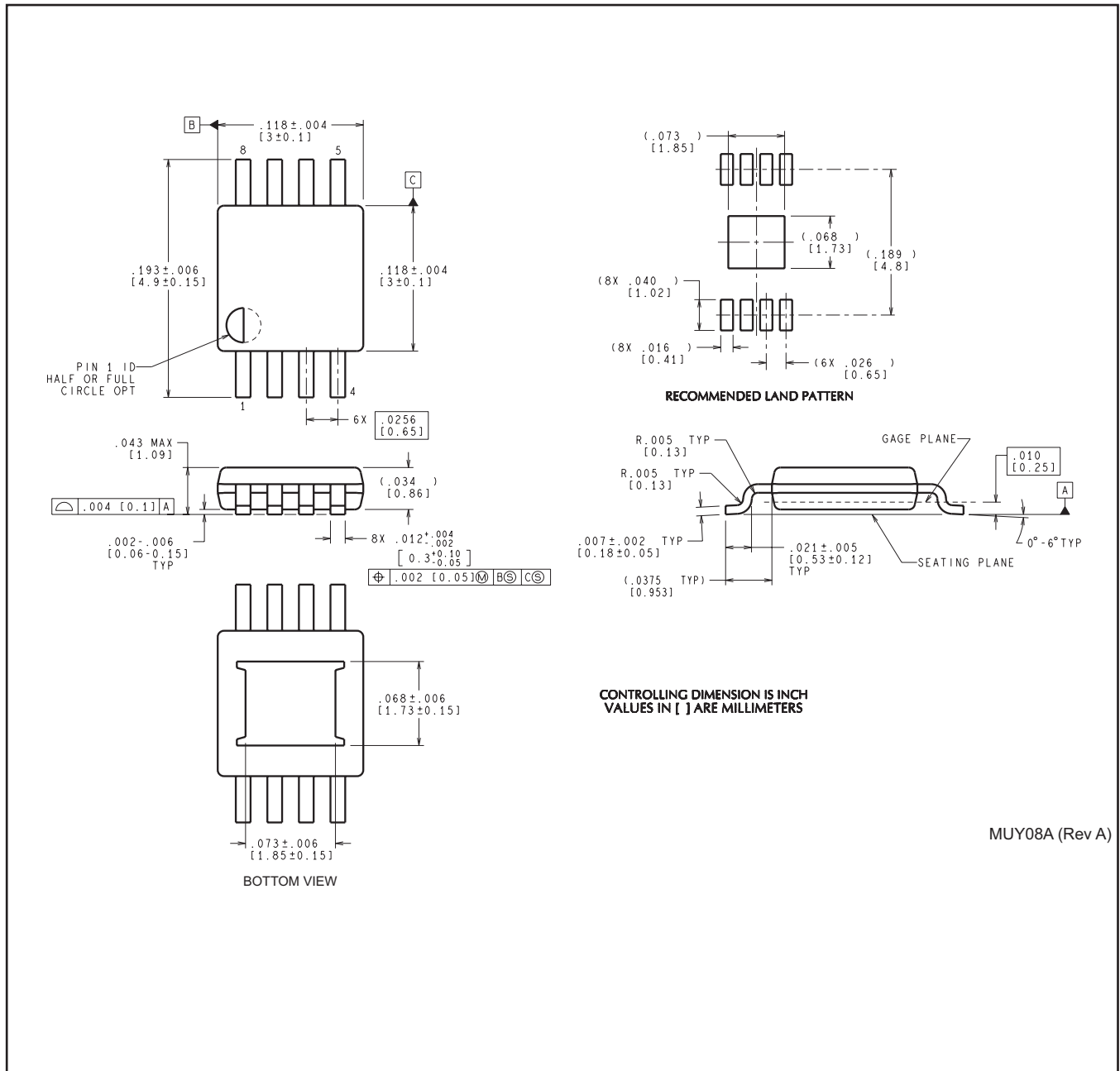

MUY08A (Rev A)

NGG0006A



RECOMMENDED LAND PATTERN

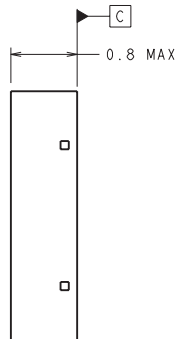
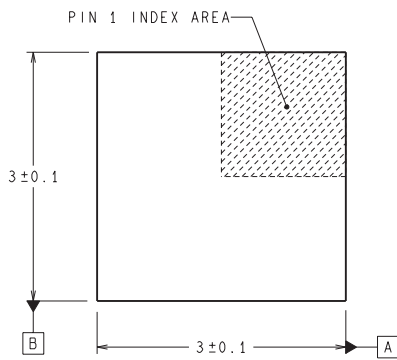

DIMENSIONS ARE IN MILLIMETERS
DIMENSION IN () FOR REFERENCE ONLY

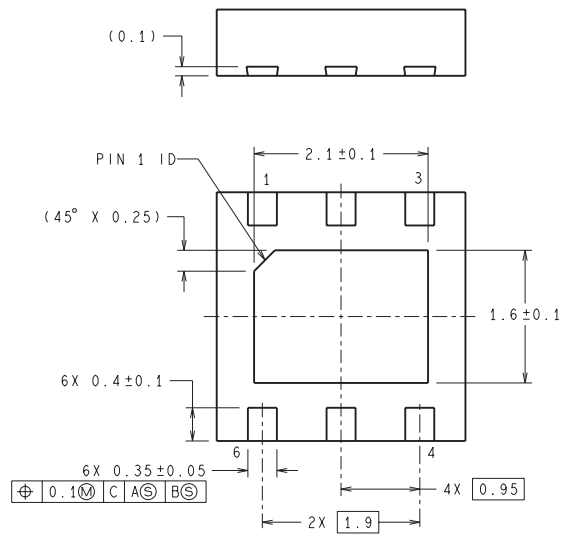

SDE06A (Rev A)

IMPORTANT NOTICE

Texas Instruments Incorporated and its subsidiaries (TI) reserve the right to make corrections, enhancements, improvements and other changes to its semiconductor products and services per JESD46, latest issue, and to discontinue any product or service per JESD48, latest issue. Buyers should obtain the latest relevant information before placing orders and should verify that such information is current and complete. All semiconductor products (also referred to herein as "components") are sold subject to TI's terms and conditions of sale supplied at the time of order acknowledgment.

TI warrants performance of its components to the specifications applicable at the time of sale, in accordance with the warranty in TI's terms and conditions of sale of semiconductor products. Testing and other quality control techniques are used to the extent TI deems necessary to support this warranty. Except where mandated by applicable law, testing of all parameters of each component is not necessarily performed.

TI assumes no liability for applications assistance or the design of Buyers' products. Buyers are responsible for their products and applications using TI components. To minimize the risks associated with Buyers' products and applications, Buyers should provide adequate design and operating safeguards.

TI does not warrant or represent that any license, either express or implied, is granted under any patent right, copyright, mask work right, or other intellectual property right relating to any combination, machine, or process in which TI components or services are used. Information published by TI regarding third-party products or services does not constitute a license to use such products or services or a warranty or endorsement thereof. Use of such information may require a license from a third party under the patents or other intellectual property of the third party, or a license from TI under the patents or other intellectual property of TI.

Reproduction of significant portions of TI information in TI data books or data sheets is permissible only if reproduction is without alteration and is accompanied by all associated warranties, conditions, limitations, and notices. TI is not responsible or liable for such altered documentation. Information of third parties may be subject to additional restrictions.

Resale of TI components or services with statements different from or beyond the parameters stated by TI for that component or service voids all express and any implied warranties for the associated TI component or service and is an unfair and deceptive business practice. TI is not responsible or liable for any such statements.

Buyer acknowledges and agrees that it is solely responsible for compliance with all legal, regulatory and safety-related requirements concerning its products, and any use of TI components in its applications, notwithstanding any applications-related information or support that may be provided by TI. Buyer represents and agrees that it has all the necessary expertise to create and implement safeguards which anticipate dangerous consequences of failures, monitor failures and their consequences, lessen the likelihood of failures that might cause harm and take appropriate remedial actions. Buyer will fully indemnify TI and its representatives against any damages arising out of the use of any TI components in safety-critical applications.

In some cases, TI components may be promoted specifically to facilitate safety-related applications. With such components, TI's goal is to help enable customers to design and create their own end-product solutions that meet applicable functional safety standards and requirements. Nonetheless, such components are subject to these terms.

No TI components are authorized for use in FDA Class III (or similar life-critical medical equipment) unless authorized officers of the parties have executed a special agreement specifically governing such use.

Only those TI components which TI has specifically designated as military grade or "enhanced plastic" are designed and intended for use in military/aerospace applications or environments. Buyer acknowledges and agrees that any military or aerospace use of TI components which have **not** been so designated is solely at the Buyer's risk, and that Buyer is solely responsible for compliance with all legal and regulatory requirements in connection with such use.

TI has specifically designated certain components as meeting ISO/TS16949 requirements, mainly for automotive use. In any case of use of non-designated products, TI will not be responsible for any failure to meet ISO/TS16949.

Products

Audio	www.ti.com/audio
Amplifiers	amplifier.ti.com
Data Converters	dataconverter.ti.com
DLP® Products	www.dlp.com
DSP	dsp.ti.com
Clocks and Timers	www.ti.com/clocks
Interface	interface.ti.com
Logic	logic.ti.com
Power Mgmt	power.ti.com
Microcontrollers	microcontroller.ti.com
RFID	www.ti-rfid.com
OMAP Applications Processors	www.ti.com/omap
Wireless Connectivity	www.ti.com/wirelessconnectivity

Applications

Automotive and Transportation	www.ti.com/automotive
Communications and Telecom	www.ti.com/communications
Computers and Peripherals	www.ti.com/computers
Consumer Electronics	www.ti.com/consumer-apps
Energy and Lighting	www.ti.com/energy
Industrial	www.ti.com/industrial
Medical	www.ti.com/medical
Security	www.ti.com/security
Space, Avionics and Defense	www.ti.com/space-avionics-defense
Video and Imaging	www.ti.com/video

TI E2E Community

e2e.ti.com

AMEYA360

Components Supply Platform

Authorized Distribution Brand :



Website :

Welcome to visit www.ameya360.com

Contact Us :

➤ Address :

401 Building No.5, JiuGe Business Center, Lane 2301, Yishan Rd
Minhang District, Shanghai , China

➤ Sales :

Direct +86 (21) 6401-6692

Email amall@ameya360.com

QQ 800077892

Skype [ameyasales1](#) [ameyasales2](#)

➤ Customer Service :

Email service@ameya360.com

➤ Partnership :

Tel +86 (21) 64016692-8333

Email mkt@ameya360.com