

General Description

The Cypress S70GL02GS 2-Gigabit MirrorBit® Flash memory device is fabricated on 65 nm MirrorBit Eclipse process technology. This device offers a fast page access time of 25 ns with a corresponding random access time of 110 ns. It features a Write Buffer that allows a maximum of 256 words/512 bytes to be programmed in one operation, resulting in faster effective programming time than standard single byte/word programming algorithms. This makes the device an ideal product for today's embedded applications that require higher density, better performance and lower power consumption.

This document contains information for the S70GL02GS device, which is a dual die stack of two S29GL01GS die. For detailed specifications, please refer to the discrete die data sheet:

Document	Cypress Document Number
S29GL01GS Data Sheet	001-98285

Distinctive Characteristics

- CMOS 3.0 Volt Core with Versatile I/O™
- Two 1024 Megabit (S29GL01GS) in a single 64-ball Fortified-BGA package (see [S29GL01GS datasheet for full specifications](#))
- 65 nm MirrorBit Eclipse™ process technology
- Single supply (V_{CC}) for read / program / erase (2.7V to 3.6V)
- Versatile I/O Feature
 - Wide I/O voltage (VIO): 1.65V to V_{CC}
- x16 data bus
- 16-word/32-byte page read buffer
- 512-byte Programming Buffer
 - Programming in Page multiples, up to a maximum of 512 bytes
- Sector Erase
 - Uniform 128-kbytes sectors
 - S70GL02GS: two thousand forty-eight sectors
- Suspend and Resume commands for Program and Erase operations
- Status Register, Data Polling, and Ready/Busy pin methods to determine device status
- Advanced Sector Protection (ASP)
 - Volatile and non-volatile protection methods for each sector
- Separate 1024-byte One Time Program (OTP) array with two lockable regions
 - Available in each device Support for CFI (Common Flash Interface)
- WP# input
 - Protects first or last sector, or first and last sectors of each device, regardless of sector protection settings
- Industrial temperature range (-40°C to $+85^{\circ}\text{C}$)
- 100,000 erase cycles per sector typical
- 20-year data retention typical
- Packaging Options
 - 64-ball LSH Fortified BGA, 13 mm x 11 mm

Performance Characteristics

Max. Read Access Times (ns) (Note 1)		
Parameter	2 Gb	
Random Access Time (t_{ACC})	110	120
Page Access Time (t_{PACC})	20	30
CE# Access Time (t_{CE})	110	120
OE# Access Time (t_{OE})	25	35

Notes

1. Access times are dependent on V_{IO} operating ranges. See Ordering Information on page 3 for further details.
2. Contact a sales representative for availability.

Typical Program and Erase Rates	
Buffer Programming (512 bytes)	1.5 MB/s
Sector Erase (128 kbytes)	477 kB/s

Maximum Current Consumption	
Active Read at 5 MHz, 30 pF	60 mA
Program	100 mA
Erase	100 mA
Standby	200 μA

Contents

General Description	1
Distinctive Characteristics	1
Performance Characteristics	1
1. Ordering Information	3
1.1 Recommended Combinations.....	3
2. Input/Output Descriptions and Logic Symbol	4
3. Block Diagrams	5
3.1 Special Handling Instructions for BGA Package.....	8
3.2 LSH064—64 ball Fortified Ball Grid Array, 13 x 11 mm.	9
4. Memory Map	10
5. Autoselect	10
6. DC Characteristics	11
7. BGA Package Capacitance	12
8. Device ID and Common Flash Interface (ID-CFI) ASO Map	13
9. Revision History	18

1. Ordering Information

1.1 Recommended Combinations

Recommended Combinations table below list various configurations planned to be available in volume. The table below will be updated as new combinations are released. Check with your local sales representative to confirm availability of specific configuration not listed or to check on newly released combinations.

S29GL-S Valid Combinations					
Base OPN	Speed (ns)	Package and Temperature	Model Number	Packing Type	Ordering Part Number (yy = Model Number, x = Packing Type)
S70GL02GS	110	FHI, FHV (Note 1)	01, 02	0, 3 (Note 2)	S70GL02GS11FHI01x S70GL02GS11FHI02x S70GL02GS11FHV01x S70GL02GS11FHV02x
	120		V1, V2		S70GL02GS12FHIV1x S70GL02GS12FHIV2x S70GL02GS12FHV1x S70GL02GS12FHV2x

Notes

1. BGA package marking omits leading "S70" and packing type designator from ordering part number.
2. Packing Type "0" is standard option.

The ordering part number is formed by a valid combination of the following:

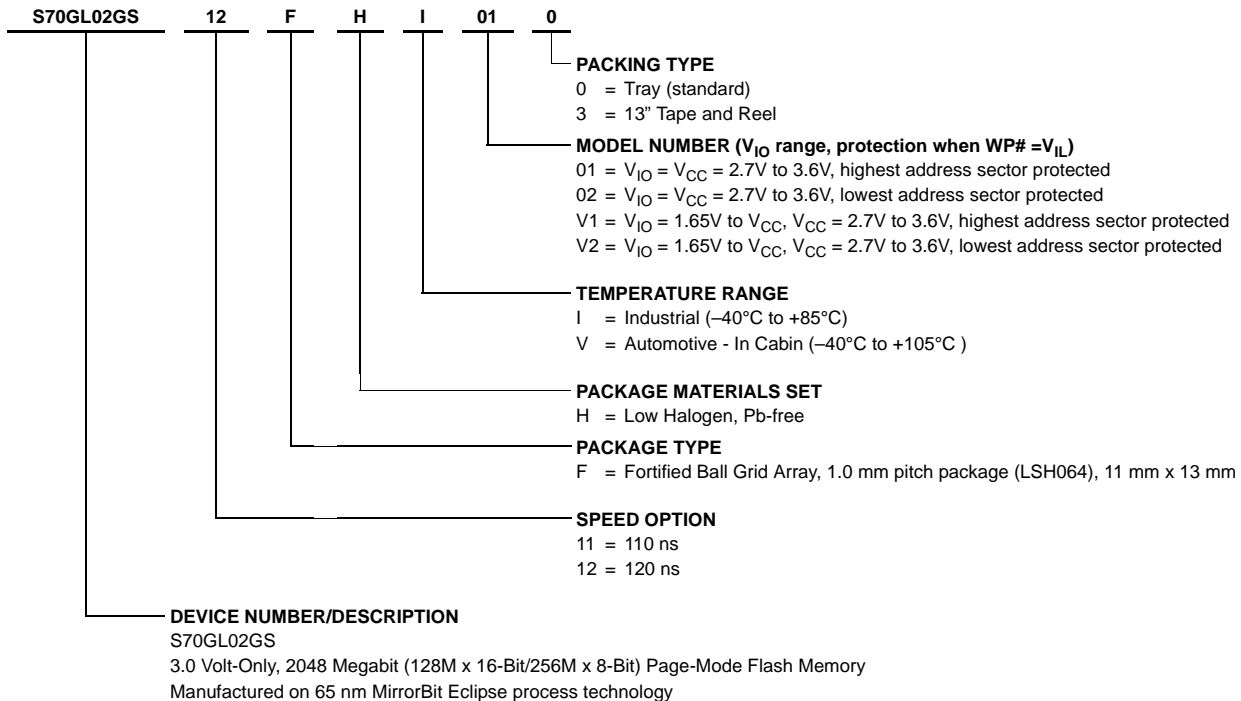

2. Input/Output Descriptions and Logic Symbol

Table 2.1 identifies the input and output package connections provided on the device.

Table 2.1 Input/Output Descriptions

Symbol	Type	Description
A26–A0	Input	Address lines for GL02GS.
DQ15–DQ0	I/O	Data input/output.
CE#	Input	Chip Enable.
OE#	Input	Output Enable.
WE#	Input	Write Enable.
V _{CC}	Supply	Device Power Supply.
V _{IO}	Supply	Versatile IO Input.
V _{SS}	Supply	Ground.
RY/BY#	Output	Ready/Busy. Indicates whether an Embedded Algorithm is in progress or complete. At V _{IL} , the device is actively erasing or programming. At High Z, the device is in ready.
RESET#	Input	Hardware Reset. Low = device resets and returns to reading array data.
WP#	Input	Write Protect/Acceleration Input. At V _{IL} , disables program and erase functions in the outermost sectors. At V _{HH} , accelerates programming; automatically places device in unlock bypass mode. Should be at V _{IH} for all other conditions.
NC	No Connect	Not Connected. No device internal signal is connected to the package connector nor is there any future plan to use the connector for a signal. The connection may safely be used for routing space for a signal on a Printed Circuit Board (PCB).
DNU	Reserved	Do Not Use. A device internal signal may be connected to the package connector. The connection may be used by Cypress for test or other purposes and is not intended for connection to any host system signal. Any DNU signal related function will be inactive when the signal is at V _{IL} . The signal has an internal pull-down resistor and may be left unconnected in the host system or may be tied to V _{SS} . Do not use these connections for PCB signal routing channels. Do not connect any host system signal to these connections.
RFU	No Connect	Reserved for Future Use. No device internal signal is currently connected to the package connector but there is potential future use for the connector for a signal. It is recommended to not use RFU connectors for PCB routing channels so that the PCB may take advantage of future enhanced features in compatible footprint devices.

3. Block Diagrams

Figure 3.1 Block Diagram for 2 x GL01GS (Highest and Lowest Address Sectors Protected)

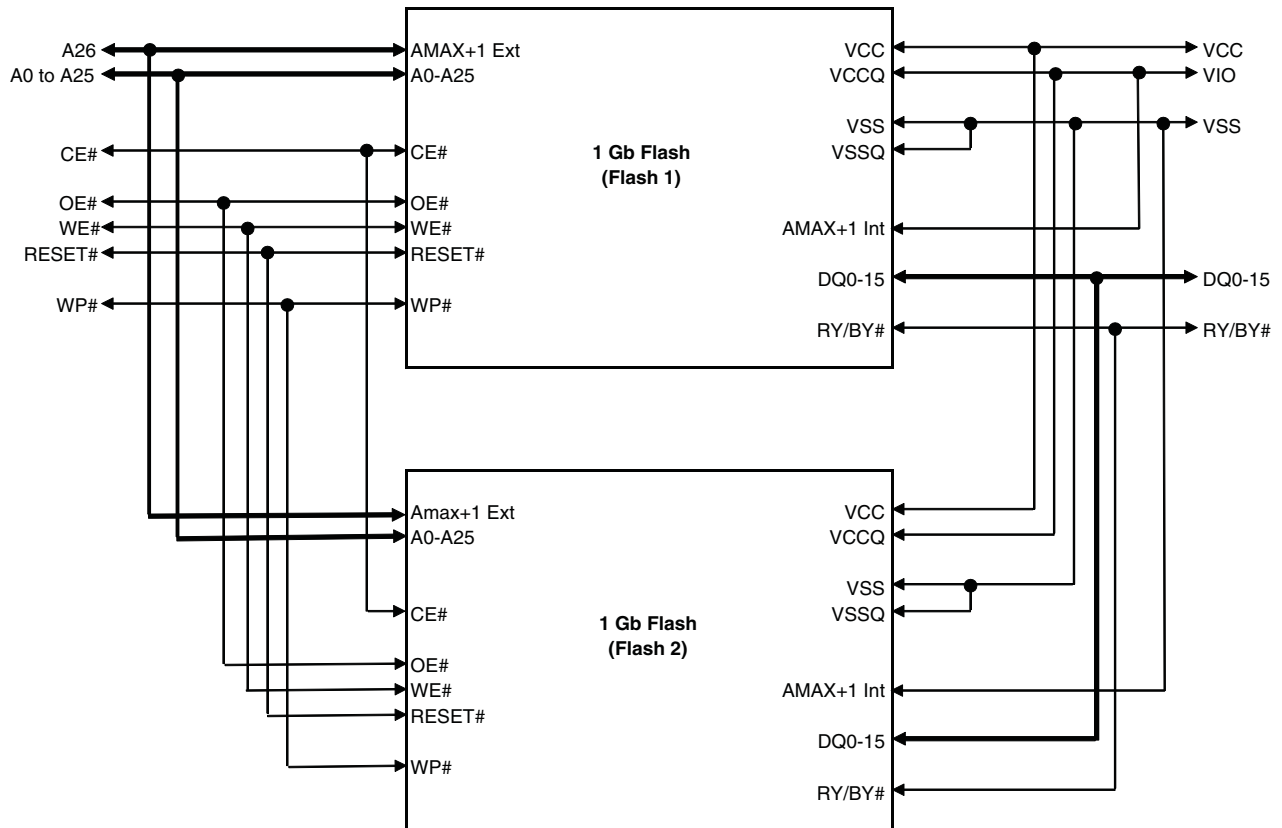

Figure 3.2 Block Diagram for 2 x GL01GS (Lowest Address Sector Protected)

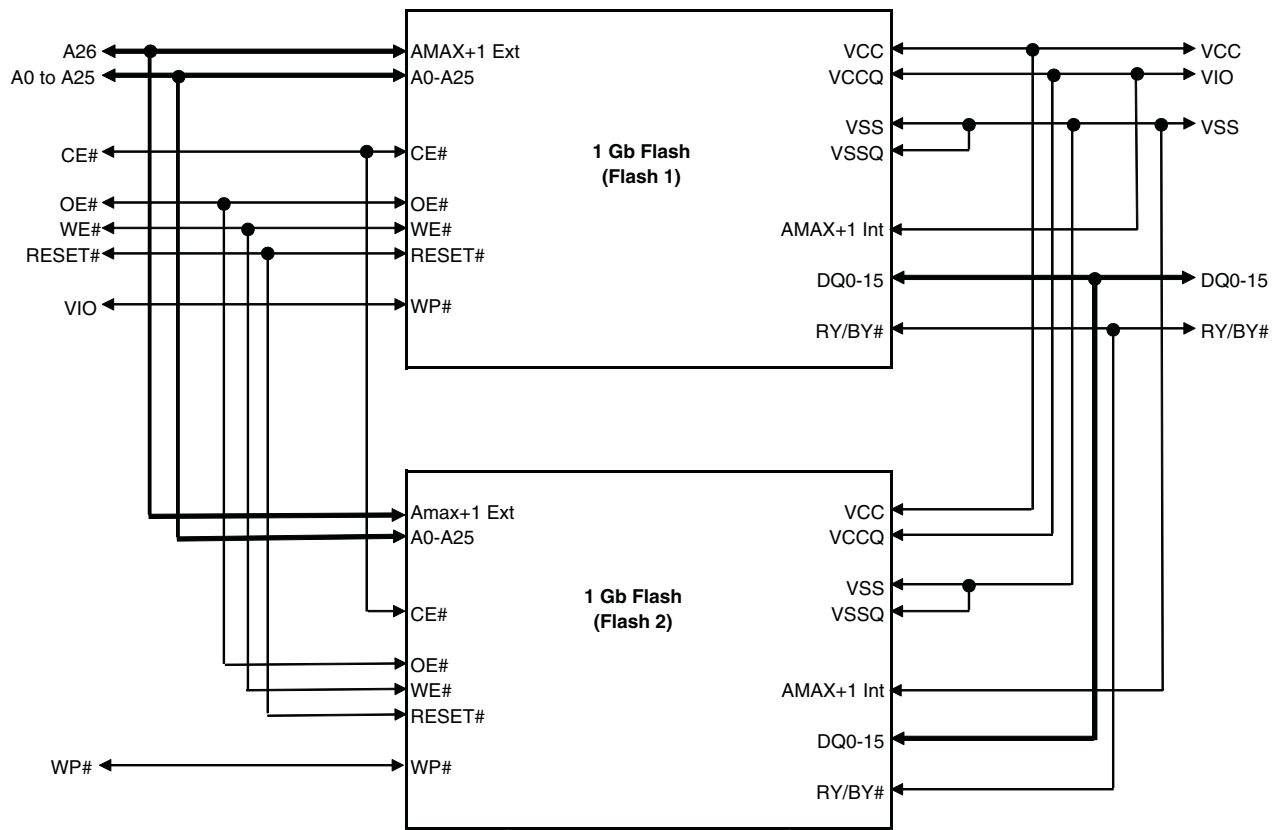
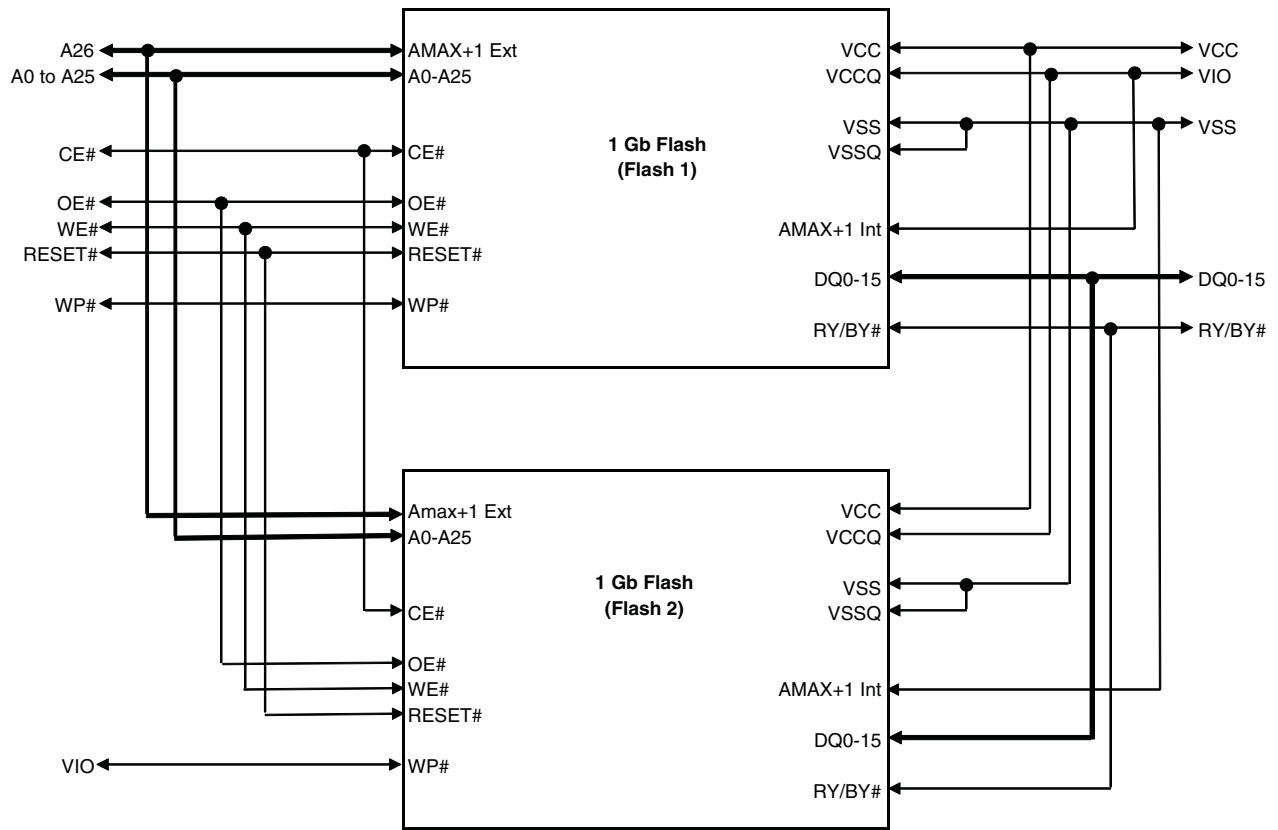

Figure 3.3 Block Diagram for 2 x GL01GS (Highest Address Sector Protected)



3.1 Special Handling Instructions for BGA Package

Special handling is required for Flash Memory products in BGA packages.

Flash memory devices in BGA packages may be damaged if exposed to ultrasonic cleaning methods. The package and/or data integrity may be compromised if the package body is exposed to temperatures above 150°C for prolonged periods of time.

Figure 3.4 64-ball Fortified Ball Grid Array

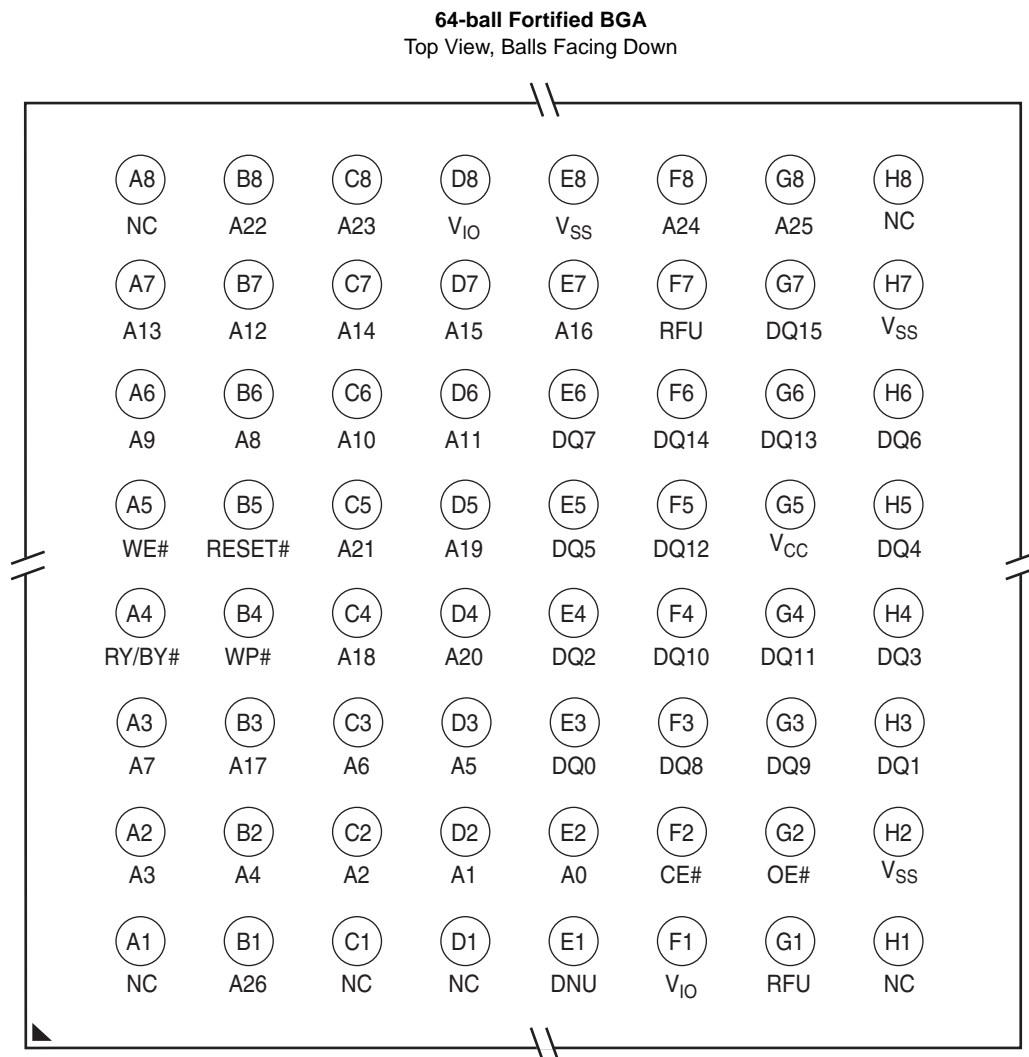

Notes

1. Ball E1, Do Not Use (DNU), a device internal signal is connected to the package connector. The connector may be used by Cypress for test or other purposes and is not intended for connection to any host system signal. Do not use these connections for PCB Signal routing channels. Though not recommended, the ball can be connected to V_{CC} or V_{SS} through a series resistor.
2. Balls F7 and G1, Reserved for Future Use (RFU).
3. Balls A1, A8, C1, D1, H1, and H8, No Connect (NC).

3.2 LSH064—64 ball Fortified Ball Grid Array, 13 x 11 mm

Figure 3.5 LSH064—64-ball Fortified Ball Grid Array (FBGA), 13 x 11 mm

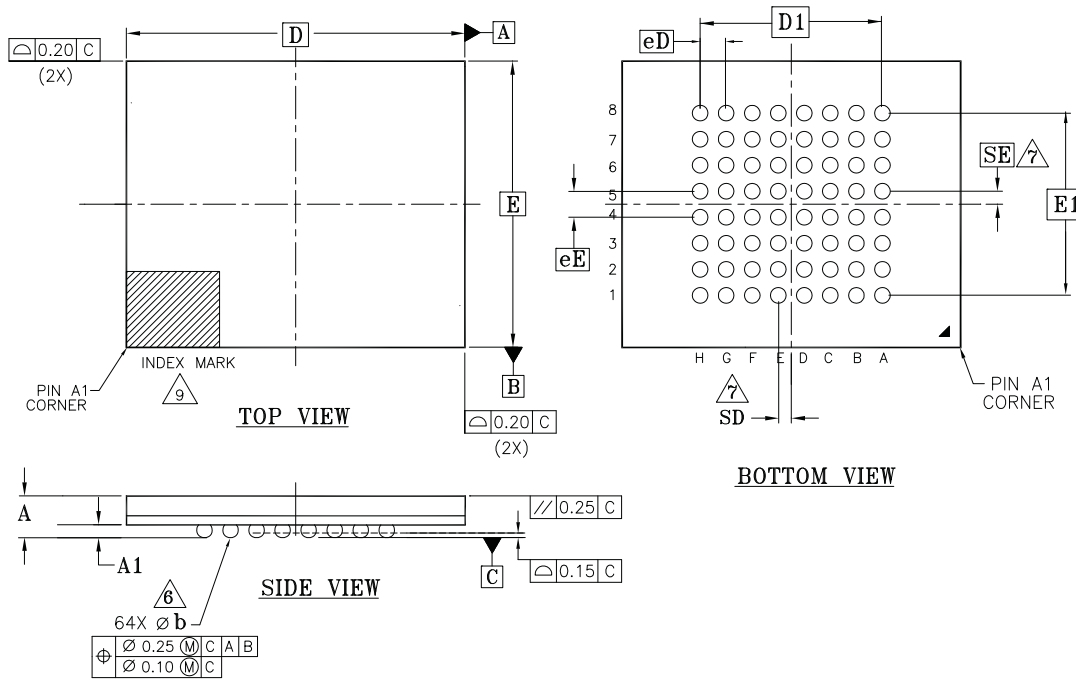

PACKAGE	LSH 064			
JEDEC	N/A			
DXE	13.00 mm x 11.00 mm PACKAGE			
SYMBOL	MIN	NOM	MAX	NOTE
A	---	---	1.4	PROFILE
A1	0.40	---	---	BALL HEIGHT
D	13.00 BSC			BODY SIZE
E	11.00 BSC			BODY SIZE
D1	7.00 BSC			MATRIX FOOTPRINT
E1	7.00 BSC			MATRIX FOOTPRINT
MD	8			MATRIX SIZE D DIRECTION
ME	8			MATRIX SIZE E DIRECTION
n	64			BALL COUNT
phi b	0.50	0.60	0.70	BALL DIAMETER
eE	1.00 BSC			BALL PITCH
eD	1.00 BSC			BALL PITCH
SD/SE	0.50 BSC			SOLDER BALL PLACEMENT
				DEPOPULATED SOLDER BALLS

NOTES:

- DIMENSIONING AND TOLERANCING PER ASME Y14.5M-1994.
- ALL DIMENSIONS ARE IN MILLIMETERS.
- BALL POSITION DESIGNATION PER JEP 95, SECTION 4.3, SPP-010.
- e REPRESENTS THE SOLDER BALL GRID PITCH.
- SYMBOL "MD" IS THE BALL MATRIX SIZE IN THE "D" DIRECTION.
SYMBOL "ME" IS THE BALL MATRIX SIZE IN THE "E" DIRECTION.
n IS THE NUMBER OF POPULATED SOLDER BALL POSITIONS FOR MATRIX SIZE MD X ME.
- $\Delta 6$ DIMENSION "b" IS MEASURED AT THE MAXIMUM BALL DIAMETER IN A PLANE PARALLEL TO DATUM C.
- $\Delta 7$ SD AND SE ARE MEASURED WITH RESPECT TO DATUMS A AND B AND DEFINE THE POSITION OF THE CENTER SOLDER BALL IN THE OUTER ROW.
WHEN THERE IS AN ODD NUMBER OF SOLDER BALLS IN THE OUTER ROW SD OR SE = 0.000.
WHEN THERE IS AN EVEN NUMBER OF SOLDER BALLS IN THE OUTER ROW, SD OR SE = $\lfloor e/2 \rfloor$
- "*" INDICATES THE THEORETICAL CENTER OF DEPOPULATED BALLS.
- A1 CORNER TO BE IDENTIFIED BY CHAMFER, LASER OR INK MARK, METALLIZED MARK INDENTATION OR OTHER MEANS.

g1005.2\116-038.15\08.10.10

4. Memory Map

The S70GL02GS consist of uniform 64 kword (128-kbyte) sectors organized as shown in [Table 4.1](#).

Table 4.1 S70GL02GS Sector and Memory Address Map

Uniform Sector Size	Sector Count	Sector Range	Address Range (16-bit)	Notes
64 kword/128 kB	2048	SA00	0000000h–000FFFFh	Sector Starting Address
		:	:	
		SA2047	7FF0000H–7FFFFFFFh	Sector Ending Address

Note

This table has been condensed to show sector-related information for an entire device on a single page. Sectors and their address ranges that are not explicitly listed (such as SA001-SA2046) have sector starting and ending addresses that form the same pattern as all other sectors of that size. For example, all 128 kB sectors have the pattern xxx0000h-xxxFFFFh.

5. Autoselect

[Table 5.1](#) provides the device identification codes for the S70GL02GS. For more information on the autoselect function, refer to the S29GL-S data sheet (publication number S29GL_128S_01GS_00).

Table 5.1 Autoselect Addresses in System

Description	Address	Read Data (word/byte mode)
Manufacturer ID	(Base) + 00h	0001h
Device ID, Word 1	(Base) + 01h	227Eh
Device ID, Word 2	(Base) + 0Eh	2248h
Device ID, Word 3	(Base) + 0Fh	2201h
Secure Device Verify	(Base) + 03h	For S70GL02GS highest address sector protect: XX3Fh = Not Factory Locked XXBFh = Factory Locked For S70GL02GS lowest address sector protect: XX2Fh = Not Factory Locked XXAFh = Factory Locked
Sector Protect Verify	(SA) + 02h	xx01h/01h = Locked, xx00h/00h = Unlocked

6. DC Characteristics

Table 6.1 DC Characteristics

Parameter	Description	Test Conditions	Min	Typ (Note 2)	Max	Unit
I_{LI}	Input Load Current	$V_{IN} = V_{SS}$ to V_{CC} , $V_{CC} = V_{CC} \text{ max}$		+0.04	± 2.0	μA
I_{LO}	Output Leakage Current	$V_{OUT} = V_{SS}$ to V_{CC} , $V_{CC} = V_{CC} \text{ max}$		+0.04	± 2.0	μA
I_{CC4}	VCC Standby Current	CE#, RESET#, OE# = V_{IH} , $V_{IH} = V_{IO}$ $V_{IL} = V_{SS}$, $V_{CC} = V_{CC} \text{ max}$		140	200	μA
I_{CC5}	VCC Reset Current (Notes 2, 7)	CE# = V_{IH} , RESET# = V_{IL} , $V_{CC} = V_{CC} \text{ max}$		20	40	mA
I_{CC6}	Automatic Sleep Mode (Note 3)	$V_{IH} = V_{IO}$, $V_{IL} = V_{SS}$, $V_{CC} = V_{CC} \text{ max}$, $t_{ACC} + 30 \text{ ns}$		6	12	mA
		$V_{IH} = V_{IO}$, $V_{IL} = V_{SS}$, $V_{CC} = V_{CC} \text{ max}$, t_{ASSB}		200	300	μA
I_{CC7}	VCC Current during power up (Notes 2, 6)	RESET# = V_{IO} , CE# = V_{IO} , OE# = V_{IO} , $V_{CC} = V_{CC} \text{ max}$,		106	160	mA

Notes

- I_{CC} active while Embedded Algorithm is in progress.
- Not 100% tested.
- Automatic sleep mode enables the lower power mode when addresses remain stable for a designated time.
- $V_{IO} = 1.65\text{V}$ to V_{CC} or 2.7V to V_{CC} depending on the model.
- $V_{CC} = 3\text{V}$ and $V_{IO} = 3\text{V}$ or 1.8V . When V_{IO} is at 1.8V , I/O pins cannot operate at $>1.8\text{V}$.
- During power-up there are spikes of current demand, the system needs to be able to supply this current to insure the part initializes correctly.
- If an embedded operation is in progress at the start of reset, the current consumption will remain at the embedded operation specification until the embedded operation is stopped by the reset. If no embedded operation is in progress when reset is started, or following the stopping of an embedded operation, I_{CC7} will be drawn during the remainder of t_{RPH} . After the end of t_{RPH} the device will go to standby mode until the next read or write.
- The recommended pull-up resistor for RY/BY# output is 5k to 10k Ohms.
- For all other DC current values please refer to the [S29GL-128S_01GS_00](#) data sheet.

7. BGA Package Capacitance

Parameter Symbol	Parameter Description	Typ	Max	Unit
C _{IN}	Input Capacitance	15	16	pF
C _{OUT}	Output Capacitance	10	11	pF
A26	Highest Order Address	6	7	pF
CE#	Separated Control Pin	12	13	pF
OE#	Separated Control Pin	7	8	pF
WE#	Separated Control Pin	11	12	pF
WP#	Separated Control Pin	11	12	pF
RESET#	Separated Control Pin	8	9	pF
RY/BY#	Separated Control Pin	5	6	pF

Notes

1. Sampled, not 100% tested.
2. Test conditions TA = 25°C, f = 1.0 MHz.

8. Device ID and Common Flash Interface (ID-CFI) ASO Map

The Device ID portion of the ASO (word locations 0h to 0Fh) provides manufacturer ID, device ID, Sector Protection State, and basic feature set information for the device.

ID-CFI Location 02h displays sector protection status for the sector selected by the sector address (SA) used in the ID-CFI enter command. To read the protection status of more than one sector it is necessary to exit the ID ASO and enter the ID ASO using the new SA. The access time to read location 02h is always t_{ACC} and a read of this location requires CE# to go High before the read and return Low to initiate the read (asynchronous read access). Page mode read between location 02h and other ID locations is not supported. Page mode read between ID locations other than 02h is supported.

Table 8.1 ID (Autoselect) Address Map (Sheet 1 of 2)

Description	Address	Read Data
Manufacture ID	(SA) + 0000h	0001h
Device ID	(SA) + 0001h	227Eh
Protection Verification	(SA) + 0002h	Sector Protection State (1= Sector protected, 0= Sector unprotected). This protection state is shown only for the SA selected when entering ID-CFI ASO. Reading other SA provides undefined data. To read a different SA protection state ASO exit command must be used and then enter ID-CFI ASO again with the new SA.
Indicator Bits	(SA) + 0003h	For S70GL02GS highest address sector protect: XX3Fh = Not Factory Locked XXBFh = Factory Locked For S70GL02GS lowest address sector protect: XX2Fh = Not Factory Locked XXAFh = Factory Locked DQ15-DQ08 = 1 (Reserved) DQ7 - Factory Locked Secure Silicon Region 1 = Locked 0 = Not Locked DQ6 - Customer Locked Secure Silicon Region 1 = Locked 0 = Not Locked DQ5 = 1 (Reserved) DQ4 - WP# Protects 0 = lowest address Sector 1 = highest address Sector DQ3 - DQ0 = 1 (Reserved)
RFU	(SA) + 0004h	Reserved
	(SA) + 0005h	Reserved
	(SA) + 0006h	Reserved
	(SA) + 0007h	Reserved
	(SA) + 0008h	Reserved
	(SA) + 0009h	Reserved
	(SA) + 000Ah	Reserved
Lower Software Bits	(SA) + 000Ch	Bit 0 - Status Register Support 1 = Status Register Supported 0 = Status Register not supported Bit 1 - DQ polling Support 1 = DQ bits polling supported 0 = DQ bits polling not supported Bit 3-2 - Command Set Support 11 = reserved 10 = reserved 01 = Reduced Command Set 00 = Classic Command set Bits 4-15 - Reserved = 0
	Upper Software Bits	(SA) + 000Dh

Table 8.1 ID (Autoselect) Address Map (Sheet 2 of 2)

Description	Address	Read Data
Device ID	(SA) + 000Eh	2248h = 2 Gb
Device ID	(SA) + 000Fh	2201h

Table 8.2 CFI Query Identification String

Word Address	Data	Description
(SA) + 0010h	0051h	Query Unique ASCII string "QRY"
(SA) + 0011h	0052h	
(SA) + 0012h	0059h	
(SA) + 0013h	0002h	Primary OEM Command Set
(SA) + 0014h	0000h	
(SA) + 0015h	0040h	Address for Primary Extended Table
(SA) + 0016h	0000h	
(SA) + 0017h	0000h	Alternate OEM Command Set (00h = none exists)
(SA) + 0018h	0000h	
(SA) + 0019h	0000h	Address for Alternate OEM Extended Table (00h = none exists)
(SA) + 001Ah	0000h	

Table 8.3 CFI System Interface String

Word Address	Data	Description
(SA) + 001Bh	0027h	V _{CC} Min. (erase/program) (D7-D4: volts, D3-D0: 100 mV)
(SA) + 001Ch	0036h	V _{CC} Max. (erase/program) (D7-D4: volts, D3-D0: 100 mV)
(SA) + 001Dh	0000h	V _{PP} Min. voltage (00h = no V _{PP} pin present)
(SA) + 001Eh	0000h	V _{PP} Max. voltage (00h = no V _{PP} pin present)
(SA) + 001Fh	0008h	Typical timeout per single word write 2 ^N μs
(SA) + 0020h	0009h	Typical timeout for max multi-byte program, 2 ^N μs (00h = not supported)
(SA) + 0021h	0008h	Typical timeout per individual block erase 2 ^N ms
(SA) + 0022h	0013h (2 Gb)	Typical timeout for full chip erase 2 ^N ms (00h = not supported)
(SA) + 0023h	0001h	Max. timeout for single word write 2 ^N times typical
(SA) + 0024h	0002h	Max. timeout for buffer write 2 ^N times typical
(SA) + 0025h	0003h	Max. timeout per individual block erase 2 ^N times typical
(SA) + 0026h	0003h	Max. timeout for full chip erase 2 ^N times typical (00h = not supported)

Table 8.4 CFI Device Geometry Definition

Word Address	Data	Description
(SA) + 0027h	001Ch (2 Gb)	Device Size = 2 ^N byte
(SA) + 0028h	0001h	Flash Device Interface Description 0 = x8-only, 1 = x16-only, 2 = x8/x16 capable
(SA) + 0029h	0000h	
(SA) + 002Ah	0009h	Max. number of byte in multi-byte write = 2 ^N (00 = not supported)
(SA) + 002Bh	0000h	
(SA) + 002Ch	0001h	Number of Erase Block Regions within device 1 = Uniform Device, 2 = Boot Device
(SA) + 002Dh	00Xh	Erase Block Region 1 Information (refer to JEDEC JESD68-01 or JEP137 specifications) 00FFh, 0007h, 0000h, 0002h = 2 Gb
(SA) + 002Eh	000Xh	
(SA) + 002Fh	0000h	
(SA) + 0030h	000Xh	
(SA) + 0031h	0000h	Erase Block Region 2 Information (refer to CFI publication 100)
(SA) + 0032h	0000h	
(SA) + 0033h	0000h	
(SA) + 0034h	0000h	
(SA) + 0035h	0000h	Erase Block Region 3 Information (refer to CFI publication 100)
(SA) + 0036h	0000h	
(SA) + 0037h	0000h	
(SA) + 0038h	0000h	
(SA) + 0039h	0000h	Erase Block Region 4 Information (refer to CFI publication 100)
(SA) + 003Ah	0000h	
(SA) + 003Bh	0000h	
(SA) + 003Ch	0000h	

Table 8.5 CFI Primary Vendor-Specific Extended Query (Sheet 1 of 3)

Word Address	Data	Description
(SA) + 0040h	0050h	Query-unique ASCII string "PRI"
(SA) + 0041h	0052h	
(SA) + 0042h	0049h	
(SA) + 0043h	0031h	Major version number, ASCII
(SA) + 0044h	0035h	Minor version number, ASCII
(SA) + 0045h	001Ch	Address Sensitive Unlock (Bits 1-0) 00b = Required 01b = Not Required Process Technology (Bits 5-2) 0000b = 0.23 μm Floating Gate 0001b = 0.17 μm Floating Gate 0010b = 0.23 μm MirrorBit 0011b = 0.13 μm Floating Gate 0100b = 0.11 μm MirrorBit 0101b = 0.09 μm Floating Gate 0110b = 0.09 μm MirrorBit 0111b = 0.065 μm MirrorBit Eclipse 1000b = 0.065 μm MirrorBit 1001b = 0.045 μm MirrorBit
(SA) + 0046h	0002h	Erase Suspend 0 = Not Supported 1 = Read Only 2 = Read and Write

Table 8.5 CFI Primary Vendor-Specific Extended Query (Sheet 2 of 3)

Word Address	Data	Description
(SA) + 0047h	0001h	Sector Protect 00 = Not Supported X = Number of sectors in smallest group
(SA) + 0048h	0000h	Temporary Sector Unprotect 00 = Not Supported 01 = Supported
(SA) + 0049h	0008h	Sector Protect/Unprotect Scheme 04 = High Voltage Method 05 = Software Command Locking Method 08 = Advanced Sector Protection Method
(SA) + 004Ah	0000h	Simultaneous Operation 00 = Not Supported X = Number of banks
(SA) + 004Bh	0000h	Burst Mode Type 00 = Not Supported 01 = Supported
(SA) + 004Ch	0003h	Page Mode Type 00 = Not Supported 01 = 4 Word Page 02 = 8 Word Page 03=16 Word Page
(SA) + 004Dh	0000h	ACC (Acceleration) Supply Minimum 00 = Not Supported D7-D4: Volt D3-D0: 100 mV
(SA) + 004Eh	0000h	ACC (Acceleration) Supply Maximum 00 = Not Supported D7-D4: Volt D3-D0: 100 mV
(SA) + 004Fh	0004h (Bottom) 0005h (Top)	WP# Protection 00h = Flash device without WP Protect (No Boot) 01h = Eight 8 kB Sectors at TOP and Bottom with WP (Dual Boot) 02h = Bottom Boot Device with WP Protect (Bottom Boot) 03h = Top Boot Device with WP Protect (Top Boot) 04h = Uniform, Bottom WP Protect (Uniform Bottom Boot) 05h = Uniform, Top WP Protect (Uniform Top Boot) 06h = WP Protect for all sectors 07h = Uniform, Top or Bottom WP Protect
(SA) + 0050h	0001h	Program Suspend 00 = Not Supported 01 = Supported
(SA) +0051h	0000h	Unlock Bypass 00 = Not Supported 01 =Supported
(SA) + 0052h	0009h	Secured Silicon Sector (Customer OTP Area) Size 2 ^N (bytes)
(SA) + 0053h	008Fh	Software Features bit 0: status register polling (1 = supported, 0 = not supported) bit 1: DQ polling (1 = supported, 0 = not supported) bit 2: new program suspend/resume commands (1=supported, 0=not supported) bit 3: word programming (1 = supported, 0 = not supported) bit 4: bit-field programming (1 = supported, 0 = not supported) bit 5: autodetect programming (1 = supported, 0 = not supported) bit 6: RFU bit 7: multiple writes per Line (1 = supported, 0 = not supported)
(SA) + 0054h	0005h	Page Size = 2 ^N bytes

Table 8.5 CFI Primary Vendor-Specific Extended Query (Sheet 3 of 3)

Word Address	Data	Description
(SA) + 0055h	0006h	Erase Suspend Timeout Maximum < 2 ^N (μs)
(SA) + 0056h	0006h	Program Suspend Timeout Maximum < 2 ^N (μs)
(SA) + 0078h	0006h	Embedded Hardware Reset Timeout Maximum < 2 ^N (μs) Reset with Reset Pin
(SA) + 0079h	0009h	Non-Embedded Hardware Reset Timeout Maximum < 2 ^N (μs) Power on Reset

9. Revision History

Spanion Publication Number: S70GL-S_00

Section	Description
Revision 01 (May 19, 2011)	
	Initial release
Revision 02 (July 8, 2011)	
Performance Characteristics	Updated Typical Program and Erase Rates
Ordering Information	Updated model number description of V1 and V2
DC Characteristics	Modified Note 3
Revision 03 (September 23, 2011)	
Distinctive Characteristics	Cosmetic changes
Order Information	Updated
CFI Device Geometry Definition	Data at (SA) + 002Eh modified
Revision 04 (December 15, 2011)	
Global	Data sheet designation changed from <i>Preliminary</i> to <i>Full Production</i>
Performance Characteristics	Updated Sector Erase time
Figure: 64-ball Fortified Ball Grid Array	Added notes
BGA Package Capacitance	Updated
Revision 05 (June 27, 2014)	
Global	Added -40°C to +105°C temperature range

Document History Page

Document Title: S70GL02GS 2 Gbit (256 Mbyte) 3.0V Flash Memory Document Number: 001-98296				
Rev.	ECN No.	Orig. of Change	Submission Date	Description of Change
**	—	BWHA	05/19/2011	Initial release
*A	—	BWHA	07/08/2011	Performance Characteristics: Updated Typical Program and Erase Rates Ordering Information: Updated model number description of V1 and V2 DC Characteristics: Modified Note 3
*B	—	BWHA	09/23/2011	Distinctive Characteristics: Cosmetic changes Ordering Information: Updated CFI Device Geometry Definition: Data at (SA) + 002Eh modified
*C	—	BWHA	12/15/2011	Global: Data sheet designation changed from Preliminary to Full Production Performance Characteristics: Updated Sector Erase time Figure: 64-ball Fortified Ball Grid Array: Added notes BGA Package Capacitance: Updated
*D	—	BWHA	06/27/2014	Global: Added -40°C to +105°C temperature range
*E	4871480	BWHA	08/13/2015	Updated to Cypress template
*F	5157725	TOCU	03/04/2016	General Description: Updated Cypress Document Number as "001-98285" in the table. Distinctive Characteristics: Updated link to S29GL01GS datasheet. Updated to new template.
*G	5343030	TOCU	07/08/2016	Updated Document Title to read as "S70GL02GS 2 Gbit (256 Mbyte) 3.0V Flash Memory". Updated to new template.

Sales, Solutions, and Legal Information

Worldwide Sales and Design Support

Cypress maintains a worldwide network of offices, solution centers, manufacturer's representatives, and distributors. To find the office closest to you, visit us at [Cypress Locations](#).

Products

ARM® Cortex® Microcontrollers	cypress.com/arm
Automotive	cypress.com/automotive
Clocks & Buffers	cypress.com/clocks
Interface	cypress.com/interface
Lighting & Power Control	cypress.com/powerpsoc
Memory	cypress.com/memory
PSoC	cypress.com/psoc
Touch Sensing	cypress.com/touch
USB Controllers	cypress.com/usb
Wireless/RF	cypress.com/wireless

PSoC® Solutions

[PSoC 1](#) | [PSoC 3](#) | [PSoC 4](#) | [PSoC 5LP](#)

Cypress Developer Community

[Forums](#) | [Projects](#) | [Video](#) | [Blogs](#) | [Training](#) | [Components](#)

Technical Support

cypress.com/support

© Cypress Semiconductor Corporation 2011-2016. This document is the property of Cypress Semiconductor Corporation and its subsidiaries, including Spansion LLC ("Cypress"). This document, including any software or firmware included or referenced in this document ("Software"), is owned by Cypress under the intellectual property laws and treaties of the United States and other countries worldwide. Cypress reserves all rights under such laws and treaties and does not, except as specifically stated in this paragraph, grant any license under its patents, copyrights, trademarks, or other intellectual property rights. If the Software is not accompanied by a license agreement and you do not otherwise have a written agreement with Cypress governing the use of the Software, then Cypress hereby grants you under its copyright rights in the Software, a personal, non-exclusive, nontransferable license (without the right to sublicense) (a) for Software provided in source code form, to modify and reproduce the Software solely for use with Cypress hardware products, only internally within your organization, and (b) to distribute the Software in binary code form externally to end users (either directly or indirectly through resellers and distributors), solely for use on Cypress hardware product units. Cypress also grants you a personal, non-exclusive, nontransferable, license (without the right to sublicense) under those claims of Cypress's patents that are infringed by the Software (as provided by Cypress, unmodified) to make, use, distribute, and import the Software solely to the minimum extent that is necessary for you to exercise your rights under the copyright license granted in the previous sentence. Any other use, reproduction, modification, translation, or compilation of the Software is prohibited.

CYPRESS MAKES NO WARRANTY OF ANY KIND, EXPRESS OR IMPLIED, WITH REGARD TO THIS DOCUMENT OR ANY SOFTWARE, INCLUDING, BUT NOT LIMITED TO, THE IMPLIED WARRANTIES OF MERCHANTABILITY AND FITNESS FOR A PARTICULAR PURPOSE. Cypress reserves the right to make changes to this document without further notice. Cypress does not assume any liability arising out of the application or use of any product or circuit described in this document. Any information provided in this document, including any sample design information or programming code, is provided only for reference purposes. It is the responsibility of the user of this document to properly design, program, and test the functionality and safety of any application made of this information and any resulting product. Cypress products are not designed, intended, or authorized for use as critical components in systems designed or intended for the operation of weapons, weapons systems, nuclear installations, life-support devices or systems, other medical devices or systems (including resuscitation equipment and surgical implants), pollution control or hazardous substances management, or other uses where the failure of the device or system could cause personal injury, death, or property damage ("Unintended Uses"). A critical component is any component of a device or system whose failure to perform can be reasonably expected to cause the failure of the device or system, or to affect its safety or effectiveness. Cypress is not liable, in whole or in part, and Company shall and hereby does release Cypress from any claim, damage, or other liability arising from or related to all Unintended Uses of Cypress products. Company shall indemnify and hold Cypress harmless from and against all claims, costs, damages, and other liabilities, including claims for personal injury or death, arising from or related to any Unintended Uses of Cypress products.

Cypress, the Cypress logo, Spansion, the Spansion logo, and combinations thereof, PSoC, CapSense, EZ-USB, F-RAM, and Traveo are trademarks or registered trademarks of Cypress in the United States and other countries. For a more complete list of Cypress trademarks, visit cypress.com. Other names and brands may be claimed as property of their respective owners.

AMEYA360

Components Supply Platform

Authorized Distribution Brand :



Website :

Welcome to visit www.ameya360.com

Contact Us :

➤ Address :

401 Building No.5, JiuGe Business Center, Lane 2301, Yishan Rd
Minhang District, Shanghai , China

➤ Sales :

Direct +86 (21) 6401-6692

Email amall@ameya360.com

QQ 800077892

Skype [ameyasales1](#) [ameyasales2](#)

➤ Customer Service :

Email service@ameya360.com

➤ Partnership :

Tel +86 (21) 64016692-8333

Email mkt@ameya360.com