

 **QUANTUM**
RESEARCH GROUP

E6248

User Manual

E6248

OVERVIEW

Standalone Board Mode

A 24 key matrix panel is integrated into the E6248 together with LED key indicators. A 14-pin header allows connection to an external matrix panel if required. To operate the board, plug it into a live USB socket.

Main User Interface

This kit is designed for evaluation and development of QT60248 and QT60168-based behind-the-panel touch matrix circuits. It includes all circuitry and materials required to make a fully-functioning, 24-key matrix touch control. This board has a virtual RS232 serial interface via the USB port that allows connection to a PC for function setup and data viewing. The E6248 makes use of QmBtn™ software, which is included.

Chip/ Subsidiary Interface

The QT chip on this board uses SPI for communications. This is directly available on connector J4.

For more detailed information please refer to the QT60248 datasheet.

Materials Provided:

- 1x E6248 eval board
- 1x USB cable
- 1x SPI cable for direct connection to the QT60248
- 1x CD-ROM with software and drivers (or get the latest version from www.qprox.com/toolbox)
- 1x User guide
- 2x QT60248 samples

You Will Also Need

A PC running any recent version of Windows 2000, XP or upwards, with a free USB port.

Turn to *Software Installation* on page 12 and follow the instructions:

- Install the QMBtn software as described — *do not run the software yet*
- Connect the E6248 to a free USB port on your PC with the cable provided
- Install the drivers in response to the *Found New Hardware Wizard* — note that this may not be necessary if you have previously installed Quantum hardware on your PC
- Your hardware and software should now be installed correctly

Double click on the QMBtn software icon to run the program:

The software should automatically detect and configure the E6248 device — if not, please refer to the *Troubleshooter* (inside back cover). The main features of the software are described on the following pages.

Make sure that you explore all of the features of the software, in particular:

- The **main window** (*QmBtn*) which provides the ability to monitor the status of all keys and the overall device in real time.
- The **settings window** (*QmSettings*) which allows you to adjust the behaviour of the keys individually to explore the parameter space.
- The **graph window** (*QmGraph*) which allows you to directly monitor the analog outputs of individual keys and effect of the associated settings parameters.

QmBtn™ is an invaluable tool for developing and testing projects that use Quantum's QMatrix™ technology. The software is designed to communicate with a QMatrix chip via your computer's serial port. It allows you to monitor your chip's status and modify its behaviour.

MAIN WINDOW

The **main window** (*QmBtn*) displays device information and the status of each key (Cmd 0x05 and 0x8k).

The screenshot shows the QmBtn software interface with the following components and annotations:

- Buttons:**
 - Open Setup from File (blue box)
 - Save Setup to File (blue box)
 - Recalibrate Selected Key (green box)
 - Key Calibrating (red box)
 - Key in Detection (red box)
 - Key in Error (red box)
 - Device Status shows status byte return by command 0x05 (orange box)
 - Key Status shows status of the selected (not detected) key by command 0x8k (where k is key number) — click on any key to show status (orange box)
 - Reset Device (green box)
 - Recalibrate all Keys (green box)
 - Send Setup to Device (purple box)
 - Read Setup from Device (purple box)
- Table:**

Key Number	0	1	2	3	4	5	6	7
Signal Reference	374	423	409	443	496	414	812	445
	8	9	10	11	12	13	14	15
	409	360	357	407	505	471	672	333
	16	17	18	19	20	21	22	23
	516	359	359	356	350	447	361	447
- Device Status:**
 - 0, Detect
 - Calibrating
 - Key error
 - Sync error
 - EEPROM chg
 - FMEA error
 - Comms error
 - 7, Reserved
- Key 12 Status:**
 - 0, Cal error
 - Calibrating
 - Low signal
 - Detect
 - Enabled
 - Reserved
 - Reserved
 - 7, Reserved
- Buttons:** Send, Read, Reset, Recal All
- Footer:** Connected: QT60169/248, Rev. 4 COM3, 9600

APPLICATION MENU

File ▶	New	Create a new file
	Open	Open a *.btn file
	Save	Save the setup of the chip in the current *.btn file
	Save As	Save the setup of the chip in a new *.btn file
	Exit	Close the software
Options ▶	Beep On Key Down	Toggle option to generate PC beep on key activation
	Beep On Key Up	Toggle option to generate PC beep on key release
	Read After Write	Toggle option to automatically send read command after sending new setup block
	Reset After Write	Toggle option to automatically send reset command after sending new setup block
	Start/ Stop Data Log	Toggle feature to record data into a *.csv file
	QmSettings ▶	Advanced Display advanced key settings
	QmGraph ▶	Join Data Points Draw a solid line in graph
	Save Options On Close	Toggle option to save software settings on close
View ▶	Key Settings	Open the <i>QmSettings</i> window
	Graph	Open the <i>QmGraph</i> window
	Key Numbers	Toggle display of key numbers on keys
	Key Reference Level	Toggle display of key reference level on keys
	Detailed Status	Toggle display of device and key status

SETTINGS WINDOW

The **settings window** (*QmSettings*) allows you to easily visualise and modify the setup of the chip. Clicking the *Read* button in the main window will bring up the current setup of your chip. When a setup option is being modified, its value becomes bold and the *Send* button will become active to indicate that the setup displayed is different from the setup on the chip. Clicking the *Send* button will transfer the new setup block to the chip. The part must be reset for its new settings to become active.

The screenshot shows the **QmSettings** window with a table of key settings. The table has columns for key ID, coordinates, NTHR, NDRIFT, FDIL, NRD, MKS, and Scope. Several rows are highlighted in orange, indicating they are selected. Callouts point to various elements:

- Click Here to Make Changes to All Keys**: Points to the 'select All' button in the top left.
- Key Number**: Points to the 'Key' column header.
- Press Ctrl + Key to select multiple keys — changes will then apply to all selected keys**: Points to the 'select All' button and the highlighted rows.
- Setup for Individual Keys**: Points to the 'Key' column header.
- Key Settings (see below)**: Points to the 'MKS' column header.
- Option Box value becomes bold when changed**: Points to the 'MKS' column header.
- Global Settings (see below)**: Points to the 'Global Settings' tab at the bottom.
- Logging (see below)**: Points to the 'Logging' tab at the bottom.

Key	Coordinates	NTHR	NDRIFT	FDIL	NRD	MKS	Scope		
Key_0	X0 Y0	8	2.5	2	5	10.0	48	Off	Off
Key_1	X1 Y0	10	2.5	2	5	10.0	32	Off	Off
Key_2	X2 Y0	10	2.5	4	5	10.0	32	Off	Off
Key_3	X3 Y0	10	2.5	2	5	10.0	32	Off	Off
Key_4	X4 Y0	10	2.5	2	5	10.0	32	Off	Off
Key_5	X5 Y0	10	2.5	2	5	10.0	48	Off	On
Key_6	X6 Y0	10	2.5	2	5	10.0	64	Off	Off
Key_7	X7 Y0	10	2.5	4	5	10.0	48	Off	Off
Key_8	X0 Y1	10	2.5	2	5	10.0	32	Off	Off
Key_9	X1 Y1	10	2.5	4	5	10.0	32	Off	Off
Key_10	X2 Y1	10	2.5	2	5	10.0	32	Off	Off
Key_11	X3 Y1	10	2.5	2	5	10.0	32	Off	Off
Key_12	X4 Y1	10	2.5	2	5	10.0	32	Off	Off
Key_13	X5 Y1	10	2.5	2	5	10.0	48	Off	Off
Key_14	X6 Y1	15	2.5	2	5	10.0	32	Off	Off
Key_15	X7 Y1	10	2.5	2	5	10.0	32	Off	Off
Key_16	X0 Y2	8	2.5	2	5	10.0	48	Off	Off
Key_17	X1 Y2	10	2.5	2	5	10.0	48	Off	Off
Key_18	X2 Y2	10	2.5	2	5	10.0	48	Off	Off
Key_19	X3 Y2	10	2.5	2	5	10.0	48	Off	Off
Key_20	X4 Y2	10	2.5	4	5	10.0	16	Off	Off
Key_21	X5 Y2	10	2.5	2	5	10.0	48	Off	Off
Key_22	X6 Y2	10	2.5	2	5	10.0	64	Off	Off
Key_23	X7 Y2	10	2.5	2	5	10.0	48	Off	Off

KEY SETTINGS (please see your datasheet for a more detailed explanation of key settings)

NTHR — Negative Threshold is used to adjust the sensitivity of a key. Higher values make keys less sensitive. Lower values make keys more sensitive.

NDRIFT — Negative Drift is the rate at which drift compensation is carried out for a negative going signal (when a key is touched or receives increased loading). The value is in sec/ reference level. For a positive going signal, drift rate is fixed at 0.4 sec. Drift compensation helps to eliminate environmental effects on the chip.

NDIL — Negative Detection Integrator Limit allows enabling and disabling of keys and provides signal filtering. Higher values will provide more filtering but increase the response time of the key.

FDIL — Fast Detection Integrator Limit also provides filtering, but has less effect on response time. Total filtering is a combination of NDIL and FDIL, for more information on the detection integrator, refer to the datasheet for your chip.

NRD — Negative Recalibration Delay determines the maximum time a key can be active before being automatically recalibrated by the chip. The value is in seconds.

BL — Burst Length modifies key sensitivity. Higher values make the key more sensitive, lower values have the opposite effect. The correct sensitivity for a key should be achieved with BL and NTHR. As a general rule BL should be as low as possible and NTHR should range from 7 to 12.

AKS — Adjacent Key Suppression can be enabled or disabled. To become active, a key with this option enabled must receive the strongest signal relative to other AKS-enabled keys.

Scope Sync sends a positive pulse (on Pin 11 S_SYNC) that brackets the burst of a selected key.

GLOBAL SETTINGS *(changes affect all keys)*

Burst Spacing — Defines the interval from the start of one burst to the start of the next. Shorter intervals result in faster touch response time; longer intervals allow higher burst lengths and longer conversion times but slower response times.

Low Signal Limit — Sets the lowest acceptable value of signal level. If any key's reference level falls below this value, the device declares an error condition in the status bits.

Mains Sync — Allows the part to synchronise on the low frequency signal. This is generally used to synchronise acquisition on the mains cycle (50/60Hz). The frequency must be more than 10Hz.

LOGGING

These settings have no effect on the chip, they define what data will be recorded when using the Data Logger. The selected readings are recorded in a *.csv file.

E6248 SCHEMATIC

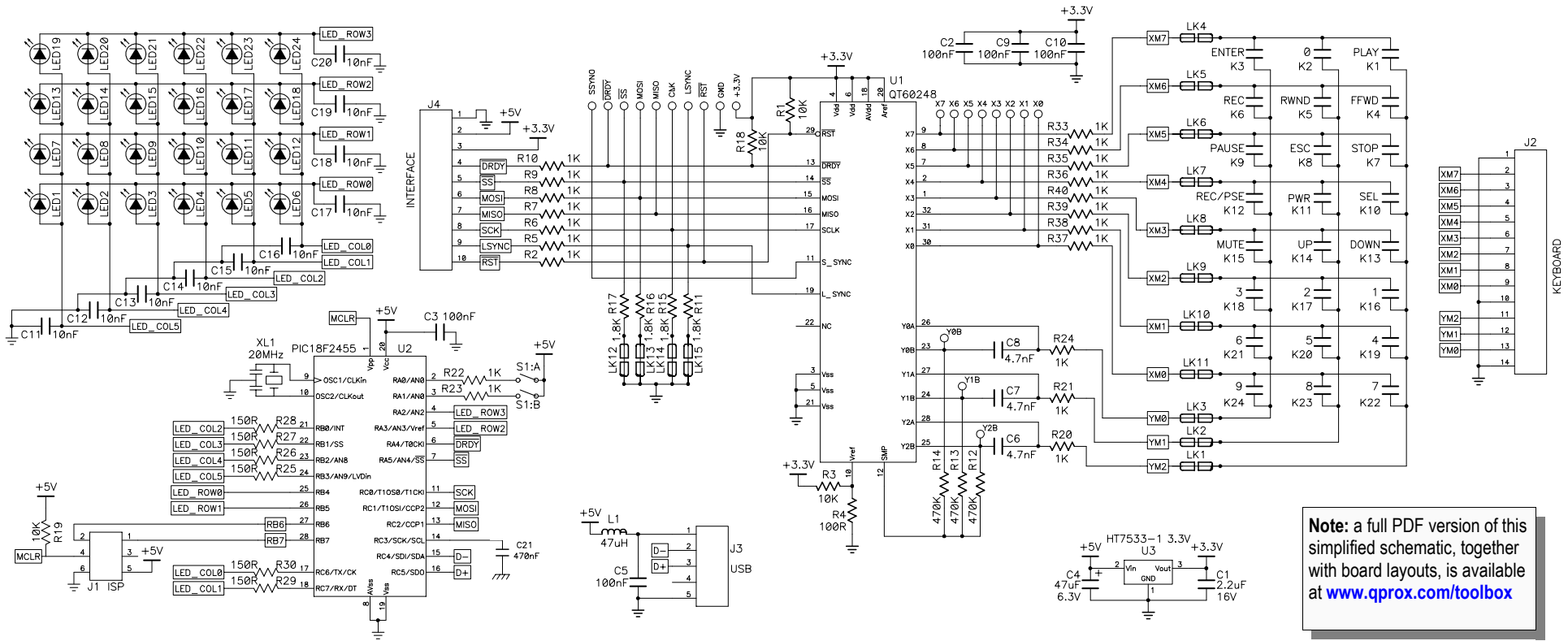

Note: a full PDF version of this simplified schematic, together with board layouts, is available at www.prox.com/toolbox

USB Connector (J3)

This connector provides direct communications between the E6248 and the PC. It allows full control over the device including calibration and setups. It also allows for real-time supervision of signal, reference and calibration information. Uses a standard USB cable (supplied) connected to a PC.

Matrix Connector (J2)

The E6248 has a header (J2) to allow connection to an external keyboard. The pinout is described below. The header provides the X-Y scanning of the matrix electrode. X lines drive charge into the matrix, and the Y lines conduct the charge back out. If an external keyboard is used it is a good idea to disconnect the on-board matrix. To do that just cut the links to the matrix (LK1..LK11). Links can be reconnected later by soldering a zero-ohm resistor on the link pads.

Pin	1	2	3	4	5	6	7	8	9	10	11	12	13	14
Name	GND	X7	X6	X5	X4	X3	X2	X1	X0	GND	Y2	Y1	Y0	GND

Communication Port Select (OPT1)

OPT1 allows the user to switch off the USB chip and communicate directly via the SPI port. The SPI signal line can be found on J5. The table below shows the different options. **If the USB chip is on, do not use the SPI line** as it could damage the evaluation board.

LED Behaviour (OPT2)

OPT2 allows the user to modify LED behaviour, from On/Off to Toggle. See table below.

State	ON	OFF
OPT1	USB chip on	USB chip off – all SPI line are floating
OPT2	Latch LED	Toggle LED

SPI Direct Port (J5)

Header J5 gives access to all the signals useful for communicating with the chip. The pinout of the connector is described below:

Pin	1	2	3	4	5	6	7	8	9	10
Name	GND	+5V	+3.3V	/DRDY	/SS	MOSI	MISO	SCK	Line Sync	RST

Line Sync (J5, pin 9)

External Noise Sync: Feed a TTL or 5V CMOS synchronization pulse into pin 9 of J5 with respect to GND.

Acquisition bursts can be synchronized to an external source of repetitive electrical noise (such as 50Hz or 60Hz) using the Noise Sync feature which can be enabled in QmBtn (View ► Key Settings ► Global Settings). External repetitive signals are thereby heavily suppressed since the system and the noise become synchronized and no longer beat or alias with respect to each other. The sync input triggers the burst for key 0 (X0Y0); the device waits for the sync signal for up to 100 ms after the end of a preceding full matrix scan (after key #23); then, when a sync pulse is received, the matrix is scanned once in its entirety. If no sync pulse is received in 100ms, the part wakes on its own and re-scans the matrix once, then goes back to sleep. Sync pulses should be spaced no more than 99ms apart to prevent this from happening.

Oscilloscope Sync (SSYNC)

The SSYNC test point can be used to synchronize an oscilloscope. When enabled in QmBtn, this signal provides a pulse that brackets the chosen burst or bursts, making diagnostics much simpler. With the scope sync enabled for one key, the X matrix drive signals can be clearly seen.

LK12..LK15

These four links provide a simple way to convert 5Volts logic levels to 3.3Volts logic levels. If the host runs at 3.3Volts, these 4 links should be disconnected (using a blade). If the host is running at 5 Volts they should be left connected.

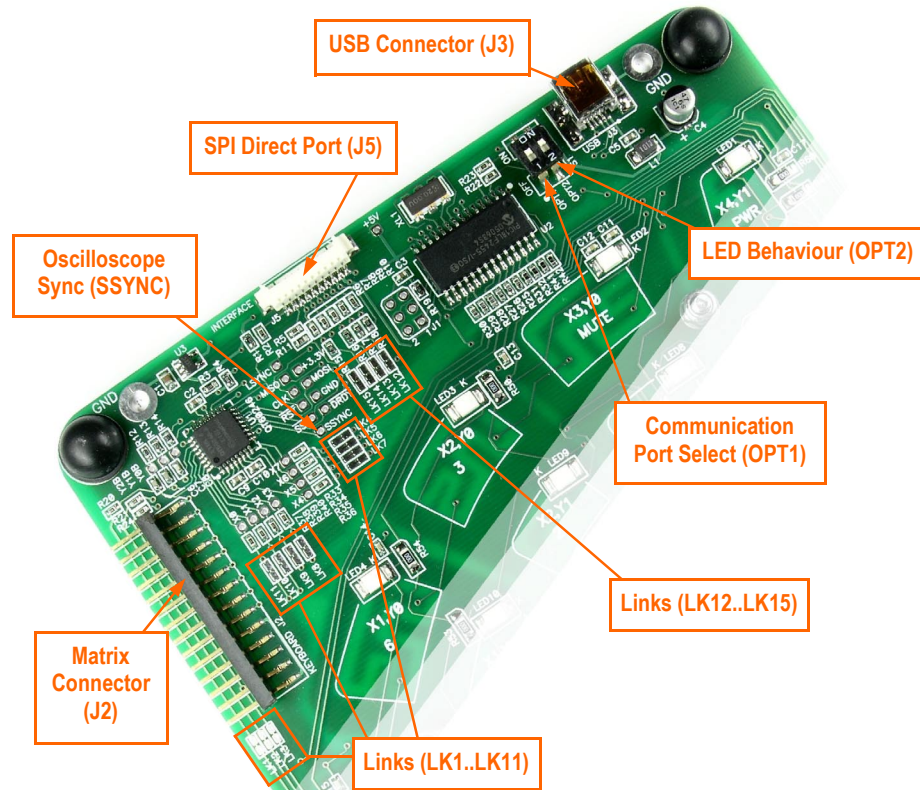

If you have a Quantum CD-ROM, follow these steps to install QmBtn™ software and USB drivers. *If you experience problems, make sure you have administrative rights (under Windows 2000 or XP Pro).*

Install the QmBtn™ Software

To install the QmBtn software, copy the file *QmBtn[...].exe* from the supplied CD to your PC. The software can be found on the CD in folder **D:\SOFTWARE** — substitute **D:** with the drive letter of your CD.

For very latest release of QmBtn, check our web site at www.qprox.com/toolbox

Install the USB Drivers

With the supplied CD-ROM in your CD drive, connect the E6248 to your PC with the supplied USB cable.

Windows will display the **Found New Hardware Wizard** for the *PICDEM FS USB*. Select **Install the software automatically** and click **Next**. Windows now installs the drivers. Click **Finish** when prompted.

Windows may prompt you to restart your PC at this point; **restarting is not necessary**.

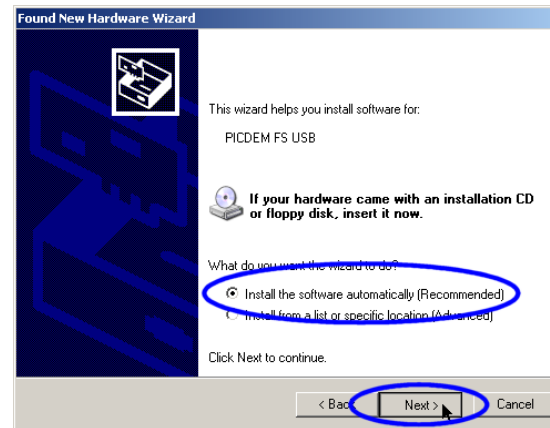

You are now done with the software and driver installation.

**Board Will
Not
Communicate
with PC****▶ Bad SPI or USB Connections**

- ⇒ Check/replace cables, LEDs should display on connection
- ⇒ Make sure the board is getting power

▶ Bad or Conflicting Virtual Comm Port on PC

- ⇒ See the *Software Installation* section - reinstall driver software, or, change the USB-Serial com port number in Device Manager if there is a conflict

▶ Incorrect Settings on Option Switch

- ⇒ Set OPT1 to the 'On' position

**Noisy or
Erratic Signal****▶ Noisy Power Supply - try a different USB port or PC****▶ Cables or Board too Close to Strong Noise Source** (such as a power line or switching noise source)

- ⇒ Increase the distance from E6248 to the noise source
- ⇒ Place a grounded metal shield between the noise source and the QMatrix™ board

▶ QMatrix™ Board is not Mechanically Stable

- ⇒ Prevent board from moving around

▶ Strong RFI from a Transmitter or Adjacent Digital Product

- ⇒ Remove the noise source or shield against it

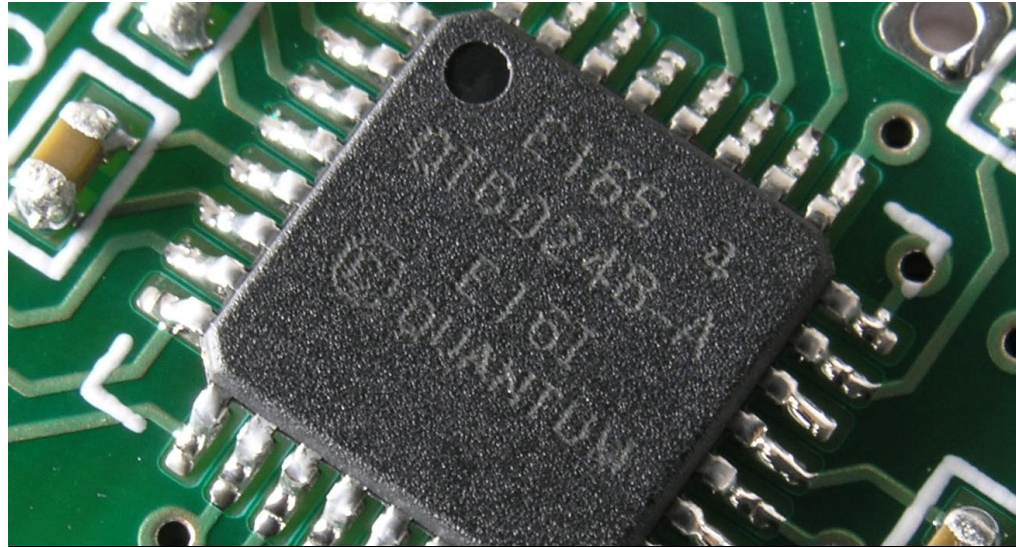

 **QUANTUM**
RESEARCH GROUP
www.qprox.com

Development: Samuel Brunet, Matthew Trend

Corporate Headquarters

1 Mitchell Point
Ensign Way, Hamble
Southampton SO31 4RF
United Kingdom

Tel +44 (0)23 8056 5600
Fax +44 (0)23 8045 3939

Email sales1@qprox.com

North America

651 Holiday Drive Bldg. 5 / 300
Pittsburgh, PA 15220
USA

Tel 412-391-7367
Fax 412-291-1015

Copyright © 2005 QRG Ltd
All rights reserved
Patented and patents pending
REV 200.170805

AMEYA360

Components Supply Platform

Authorized Distribution Brand :



Website :

Welcome to visit www.ameya360.com

Contact Us :

➤ Address :

401 Building No.5, JiuGe Business Center, Lane 2301, Yishan Rd
Minhang District, Shanghai , China

➤ Sales :

Direct +86 (21) 6401-6692

Email amall@ameya360.com

QQ 800077892

Skype [ameyasales1](#) [ameyasales2](#)

➤ Customer Service :

Email service@ameya360.com

➤ Partnership :

Tel +86 (21) 64016692-8333

Email mkt@ameya360.com