

# FSFM260N / FSFM261N / FSFM300N

## Green-Mode Fairchild Power Switch (FPS™)

### Features

- Internal Avalanche-Rugged SenseFET
- Advanced Burst-Mode Operation Consumes Under 1W at 240V<sub>AC</sub> and 0.5W Load
- Precision Fixed Operating Frequency: 67kHz
- Internal Startup Circuit
- Over-Voltage Protection (OVP)
- Overload Protection (OLP)
- Internal Thermal Shutdown Function (TSD)
- Abnormal Over-Current Protection (AOCP)
- Auto-Restart Mode
- Under-Voltage Lockout (UVLO) with Hysteresis
- Low Operating Current: 2.5mA
- Built-in Soft-Start: 15ms

### Applications

- Power Supply for LCD TV and Monitor, VCR, SVR, STB, DVD, and DVD Recorder
- Adapter

### Related Resources

Visit: <http://www.fairchildsemi.com/apnotes/> for:

- AN-4134: *Design Guidelines for Offline Forward Converters Using Fairchild Power Switch (FPS™)*
- AN-4137: *Design Guidelines for Offline Flyback Converters Using Fairchild Power Switch (FPS™)*
- AN-4140: *Transformer Design Consideration for Offline Flyback Converters Using Fairchild Power Switch (FPS™)*
- AN-4141: *Troubleshooting and Design Tips for Fairchild Power Switch (FPS™) Flyback Applications*
- AN-4145: *Electromagnetic Compatibility for Power Converters*
- AN-4147: *Design Guidelines for RCD Snubber of Flyback Converters*
- AN-4148: *Audible Noise Reduction Techniques for Fairchild Power Switch (FPS™) Applications*

### Description

The FSFM260/261/300 is an integrated Pulse Width Modulator (PWM) and SenseFET specifically designed for high-performance offline Switch Mode Power Supplies (SMPS) with minimal external components.

This device is an integrated high-voltage power-switching regulator that combines an avalanche-rugged SenseFET with a current-mode PWM control block. The PWM controller includes an integrated fixed-frequency oscillator, under-voltage lockout, leading-edge blanking (LEB), optimized gate driver, internal soft-start, temperature-compensated precise-current sources for a loop compensation, and self-protection circuitry. Compared with discrete MOSFET and PWM controller solutions, it can reduce total cost, component count, size, and weight while simultaneously increasing efficiency, productivity, and system reliability. This device is a basic platform for cost-effective designs of flyback converters.

## Ordering Information

Product Number	PKG. <sup>(5)</sup>	Operating Temp.	Current Limit	R <sub>DS(ON)</sub> Max.	Maximum Output Power <sup>(1)</sup>				Replaces Devices
					230V <sub>AC</sub> ±15% <sup>(2)</sup>		85-265V <sub>AC</sub>		
					Adapter <sup>(3)</sup>	Open Frame <sup>(4)</sup>	Adapter <sup>(3)</sup>	Open Frame <sup>(4)</sup>	
FSFM260N	8-DIP	-25 to +85°C	1.5A	2.6Ω	23W	35W	17W	26W	FSDM0465RS FSQ0465RS
FSFM261N	8-DIP	-25 to +85°C	1.5A	2.7Ω	23W	35W	17W	26W	
FSFM300N	8-DIP	-25 to +85°C	1.6A	2.2Ω	26W	40W	20W	30W	

### Notes:

1. The junction temperature can limit the maximum output power.
2. 230V<sub>AC</sub> or 100/115V<sub>AC</sub> with doubler.
3. Typical continuous power in a non-ventilated enclosed adapter measured at 50°C ambient temperature.
4. Maximum practical continuous power in an open-frame design at 50°C ambient.
5. Eco status for all the FSFM260N, FSFM261N and FSFM300NS is RoHS.



For Fairchild's definition of Eco Status, please visit:  
[http://www.fairchildsemi.com/company/green/rohs\\_green.html](http://www.fairchildsemi.com/company/green/rohs_green.html). Eco Status: RoHS.

### Application Diagram

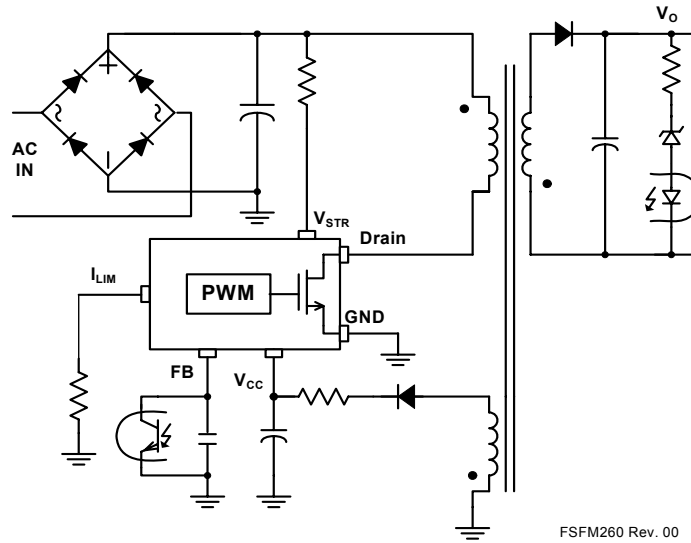

Figure 1. Typical Flyback Application

### Internal Block Diagram

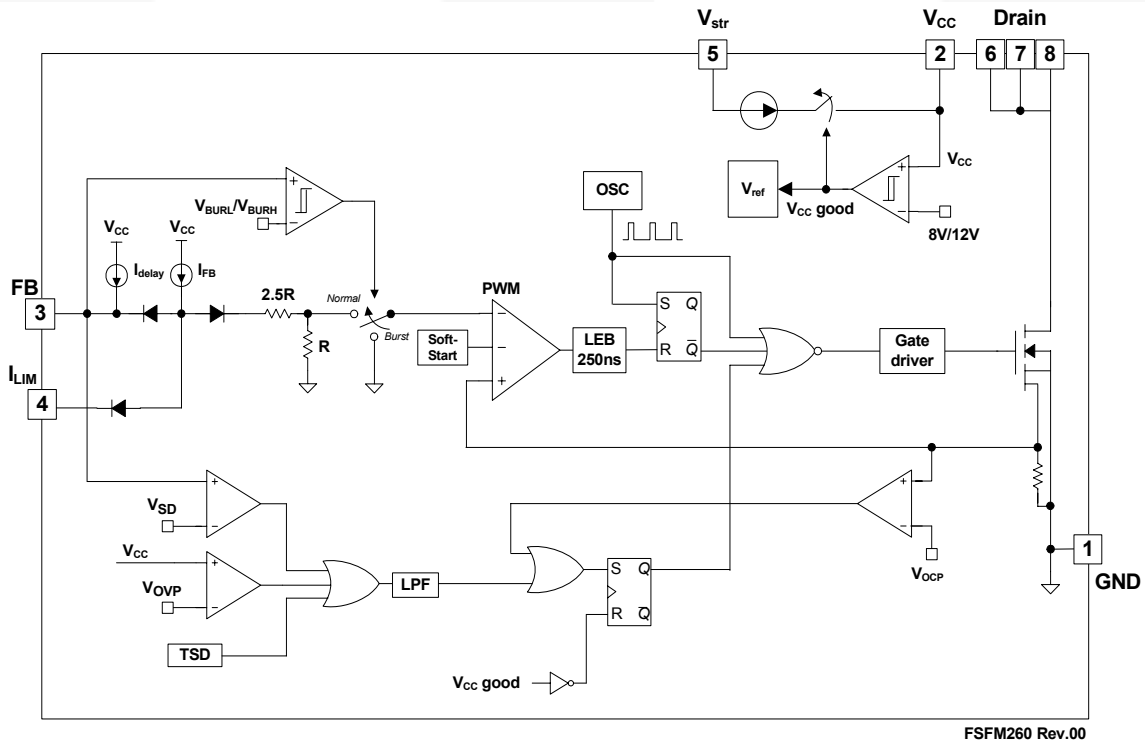
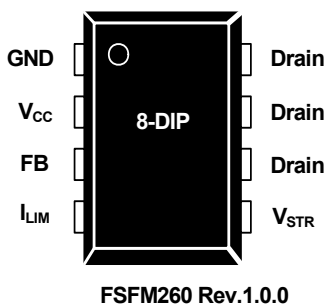

Figure 2. Internal Block Diagram

## Pin Configuration



FSFM260 Rev.1.0.0

Figure 3. Pin Configuration (Top View)

## Pin Definitions

Pin #	Name	Description
1	GND	<b>Ground.</b> This pin is the control ground and the SenseFET source.
2	$V_{CC}$	<b>Power Supply.</b> This pin is the positive supply input, providing internal operating current for both startup and steady-state operation.
3	FB	<b>Feedback.</b> This pin is internally connected to the inverting input of the PWM comparator. The collector of an opto-coupler is typically tied to this pin. For stable operation, a capacitor should be placed between this pin and GND. If the voltage of this pin reaches 6V, the overload protection triggers, which shuts down the FPS.
4	$I_{LIM}$	<b>Peak Current Limit.</b> Adjusts the peak current limit of the Sense FET. The feedback 0.9mA current source is diverted to the parallel combination of an internal 2.8k $\Omega$ resistor and any external resistor to GND on this pin to determine the peak current limit.
5	$V_{STR}$	<b>Startup.</b> This pin is connected directly, or through a resistor, to the high-voltage DC link. At startup, the internal high-voltage current source supplies internal bias and charges the external capacitor connected to the $V_{CC}$ pin. Once $V_{CC}$ reaches 12V, the internal current source is disabled. It is not recommended to connect $V_{STR}$ and drain together.
6,7,8	Drain	<b>SenseFET Drain.</b> High-voltage power SenseFET drain connection.

## Absolute Maximum Ratings

Stresses exceeding the absolute maximum ratings may damage the device. The device may not function or be operable above the recommended operating conditions and stressing the parts to these levels is not recommended. In addition, extended exposure to stresses above the recommended operating conditions may affect device reliability. The absolute maximum ratings are stress ratings only.  $T_A = 25^\circ\text{C}$ , unless otherwise specified.

Symbol	Parameter		Min.	Max.	Unit
$V_{STR}$	$V_{STR}$ Pin Voltage		650		V
$V_{DS1}$	Drain Pin Voltage of FSFM260N and FSFM300N		650		V
$V_{DS2}$	Drain Pin Voltage of FSFM261N		700		V
$V_{CC}$	Supply Voltage			21	V
$V_{FB}$	Feedback Voltage Range <sup>(6)</sup>		-0.3	8.0	V
$I_{DM}$	Drain Current Pulsed			9.6	A
$I_D$	Continuous Drain Current of FSFM260 and FSFM261 <sup>(7)</sup>	$T_C = 25^\circ\text{C}$		2.2	A
		$T_C = 100^\circ\text{C}$		1.4	
	Continuous Drain Current of FSFM300 <sup>(7)</sup>	$T_C = 25^\circ\text{C}$		2.8	
		$T_C = 100^\circ\text{C}$		1.7	
$E_{AS}$	Single Pulsed Avalanche Energy <sup>(8)</sup>	FSFM260 and FSFM261		120	mJ
		FSFM300		190	
$P_D$	Total Power Dissipation ( $T_C=25^\circ\text{C}$ )			1.5	W
$T_J$	Operating Junction Temperature		Internally Limited		$^\circ\text{C}$
$T_A$	Operating Ambient Temperature		-25	+85	$^\circ\text{C}$
$T_{STG}$	Storage Temperature		-55	+150	$^\circ\text{C}$
ESD	Electrostatic Discharge Capability Human Body Model, JESD22-A114		2.0		kV
	Electrostatic Discharge Capability, Charged Device Model, JESD22-C110		2.0		

### Notes:

6.  $V_{FB}$  is internally clamped and its maximum clamping current capability is  $100\mu\text{A}$ .
7. Repetitive rating; pulse-width limited by maximum junction temperature.
8.  $L=14\text{mH}$ , starting  $T_J=25^\circ\text{C}$ .

## Thermal Impedance

$T_A = 25^\circ\text{C}$  unless otherwise specified.

Symbol	Parameter	Package	Value	Unit
$\theta_{JA}$	Junction-to-Ambient Thermal Resistance <sup>(9)</sup>	8-DIP	80	$^\circ\text{C/W}$
$\theta_{JC}$	Junction-to-Case Thermal Resistance <sup>(10)</sup>		20	$^\circ\text{C/W}$
$\Psi_{JT}$	Junction-to-Top Thermal Resistance <sup>(11)</sup>		35	$^\circ\text{C/W}$

### Notes:

9. Free standing with no heat-sink under natural convection.
10. Infinite cooling condition - refer to the SEMI G30-88.
11. Measured on the package top surface.

## Electrical Characteristics

$T_A = 25^\circ\text{C}$  unless otherwise specified.

Symbol	Parameter	Condition	Min.	Typ.	Max.	Unit
<b>SenseFET Section</b>						
$BV_{DSS1}$	Drain Source Breakdown Voltage of FSFM260 and FSFM300	$V_{CC} = 0V, I_D = 250\mu A$	650			V
$BV_{DSS2}$	Drain Source Breakdown Voltage of FSFM261	$V_{CC} = 0V, I_D = 250\mu A$	700			V
$I_{DSS1}$	Zero Gate Voltage Drain Current1	$V_{DS} = 650V, V_{GS} = 0V, T_C = 25^\circ\text{C}$			250	$\mu A$
$I_{DSS2}$	Zero Gate Voltage Drain Current2	$V_{DS} = 520V, V_{GS} = 0V, T_C = 125^\circ\text{C}$			250	$\mu A$
$R_{DS(ON)}$	Static Drain Source on Resistance of FSFM260 <sup>(12)</sup>	$V_{GS} = 10V, I_D = 2.5A$		2.20	2.60	$\Omega$
	Static Drain Source on Resistance of FSFM261 <sup>(12)</sup>			2.30	2.70	$\Omega$
	Static Drain Source on Resistance of FSFM300 <sup>(12)</sup>			1.76	2.20	$\Omega$
$C_{OSS}$	Output Capacitance of FSFM260/261	$V_{GS} = 0V, V_{DS} = 25V, f = 1\text{MHz}$		60		pF
$t_{d(on)}$	Turn-On Delay Time of FSFM260/261	$V_{DD} = 325V, I_D = 5A$		12		ns
$t_r$	Rise Time of FSFM260/261			20		
$t_{d(off)}$	Turn-Off Delay Time of FSFM260/261			30		
$t_f$	Fall Time of FSFM260/261			16		
$C_{OSS}$	Output Capacitance of FSFM300	$V_{GS} = 0V, V_{DS} = 25V, f = 1\text{MHz}$		75		pF
$t_{d(on)}$	Turn-On Delay Time of FSFM300	$V_{DD} = 325V, I_D = 5A$		14		ns
$t_r$	Rise Time of FSFM300			26		
$t_{d(off)}$	Turn-Off Delay Time of FSFM300			32		
$t_f$	Fall Time of FSFM300			25		
<b>Control Section</b>						
$f_{OSC}$	Switching Frequency	$V_{FB} = 3V$	61	67	73	kHz
$\Delta f_{STABLE}$	Switching Frequency Stability	$13V \leq V_{CC} \leq 18V$	0	1	3	%
$\Delta f_{OSC}$	Switching Frequency Variation <sup>(13)</sup>	$-25^\circ\text{C} \leq T_A \leq 85^\circ\text{C}$	0	$\pm 5$	$\pm 10$	%
$I_{FB}$	Feedback Source Current	$V_{FB} = \text{GND}$	0.7	0.9	1.1	mA
$D_{MAX}$	Maximum Duty Cycle		71	77	83	%
$D_{MIN}$	Minimum Duty Cycle				0	%
$V_{START}$	UVLO Threshold Voltage	$V_{FB} = \text{GND}$	11	12	13	V
$V_{STOP}$			7	8	9	V
$t_{S/S}$	Internal Soft-Start Time	$V_{FB} = 3V$	10	15	20	ms
<b>Burst Mode Section</b>						
$V_{BURH}$	Burst Mode Voltages	$V_{CC} = 14V$		0.50		V
$V_{BURL}$				0.35		V

## Electrical Characteristics (Continued)

T<sub>A</sub> = 25°C unless otherwise specified.

Symbol	Parameter	Condition	Min.	Typ.	Max.	Unit	
<b>Protection Section</b>							
V <sub>SD</sub>	Shutdown Feedback Voltage	V <sub>FB</sub> ≥ 5.5V	5.5	6.0	6.5	V	
I <sub>DELAY</sub>	Shutdown Delay Current	V <sub>FB</sub> = 5V	3.5	5.0	6.5	μA	
t <sub>LEB</sub>	Leading Edge Blanking Time <sup>(13)</sup>		200			ns	
I <sub>LIMIT</sub>	Peak Current Limit	T <sub>J</sub> = 25°C, di/dt = 200mA/μs	FSFM260/ FSFM261	1.32	1.50	1.68	A
			FSFM300	1.41	1.60	1.79	
V <sub>OVP</sub>	Over-Voltage Protection		18.0	19.0	20.5	V	
T <sub>SD</sub>	Thermal Shutdown Temperature <sup>(13)</sup>		125	140		°C	
<b>Total Device Section</b>							
I <sub>OP</sub>	Operating Supply Current	V <sub>FB</sub> = GND, V <sub>CC</sub> = 14V	1	3	5	mA	
I <sub>START</sub>	Start Current	V <sub>CC</sub> = 10V (before V <sub>CC</sub> reaches V <sub>START</sub> )	150	200	250	μA	
I <sub>CH</sub>	Startup Charging Current	V <sub>CC</sub> = 0V, V <sub>STR</sub> =min. 50V	0.70	0.85	1.00	mA	
V <sub>STR</sub>	Minimum V <sub>STR</sub> Supply Voltage	at I <sub>STR</sub> <sup>IN</sup> =I <sub>START</sub>		24		V	

### Notes:

12. Pulse test: pulse width ≤ 300μs, duty ≤ 2%.
13. Guaranteed by design; not tested in production.

## Typical Performance Characteristics

Graphs are normalized at  $T_A = 25^\circ\text{C}$ .

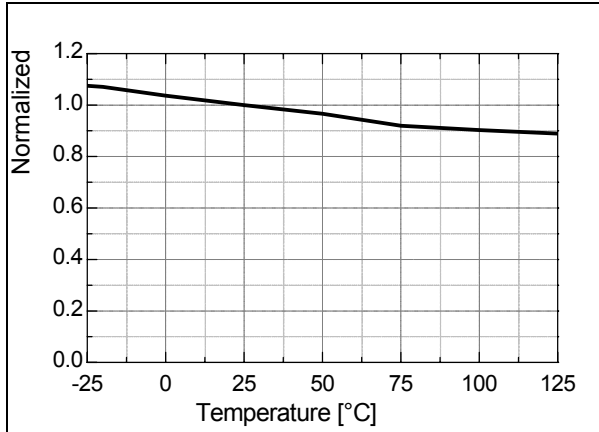

Figure 4. Operating Supply Current ( $I_{OP}$ ) vs.  $T_A$

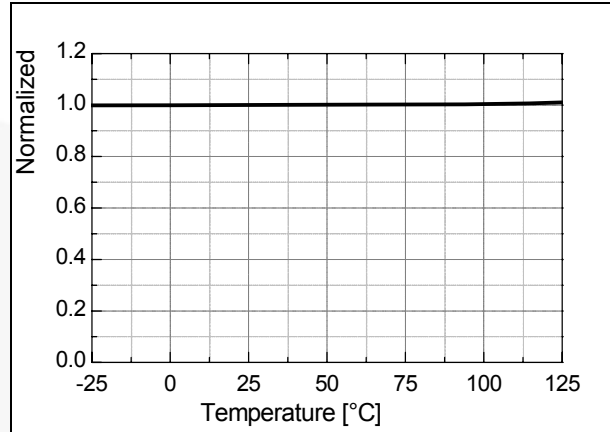

Figure 5. UVLO Start Threshold Voltage ( $V_{START}$ ) vs.  $T_A$

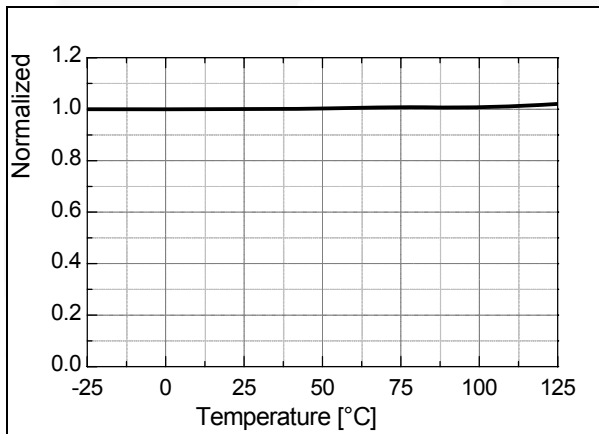

Figure 6. UVLO Stop Threshold Voltage ( $V_{STOP}$ ) vs.  $T_A$

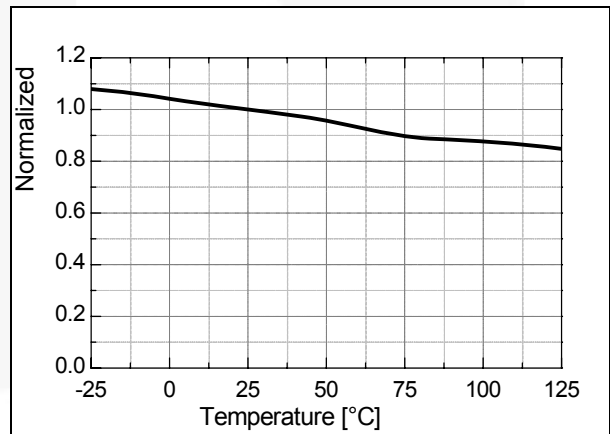

Figure 7. Startup Charging Current ( $I_{CH}$ ) vs.  $T_A$

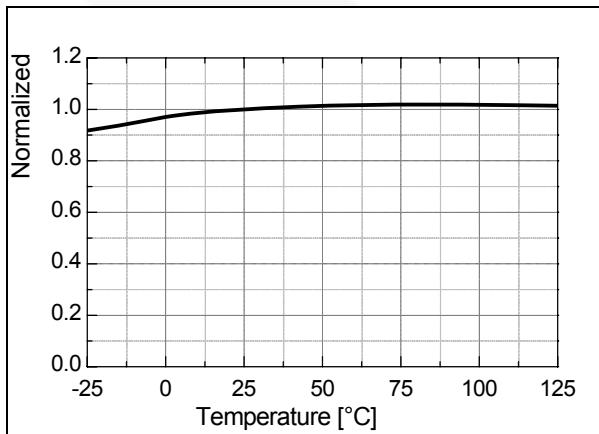

Figure 8. Switching Frequency ( $f_{OSC}$ ) vs.  $T_A$

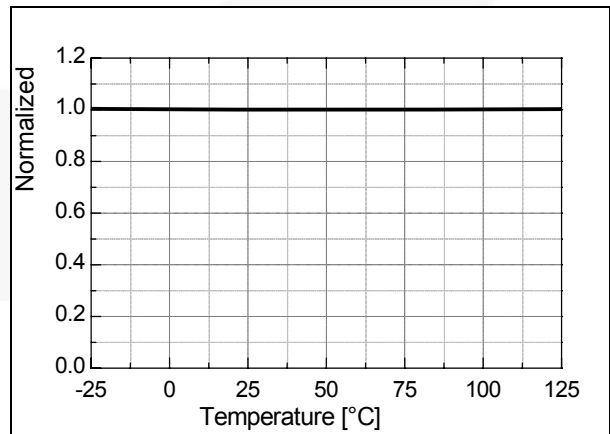

Figure 9. Maximum Duty Cycle ( $D_{MAX}$ ) vs.  $T_A$

### Typical Performance Characteristics (Continued)

Graphs are normalized at  $T_A = 25^\circ\text{C}$ .

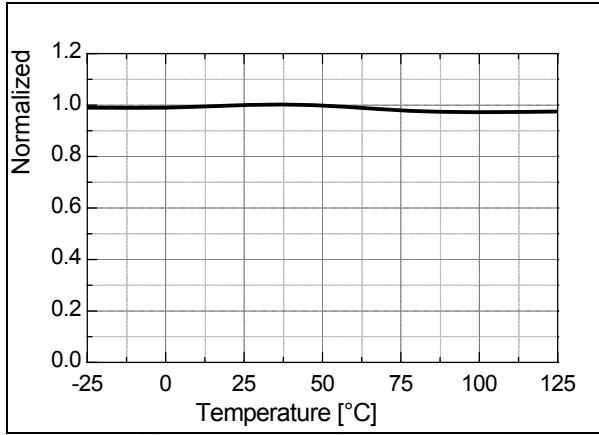

Figure 10. Over-Voltage Protection ( $V_{OVP}$ ) vs.  $T_A$

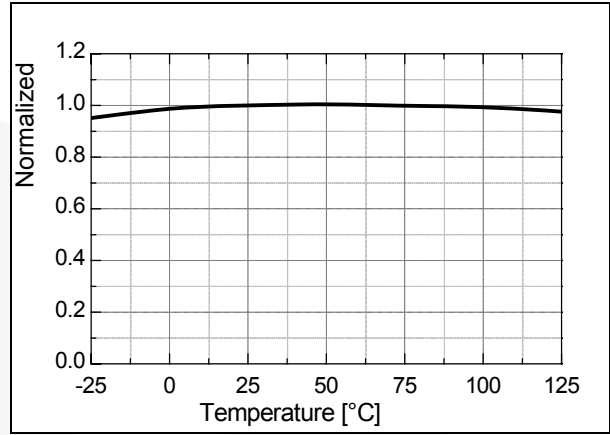

Figure 11. Feedback Source Current ( $I_{FB}$ ) vs.  $T_A$

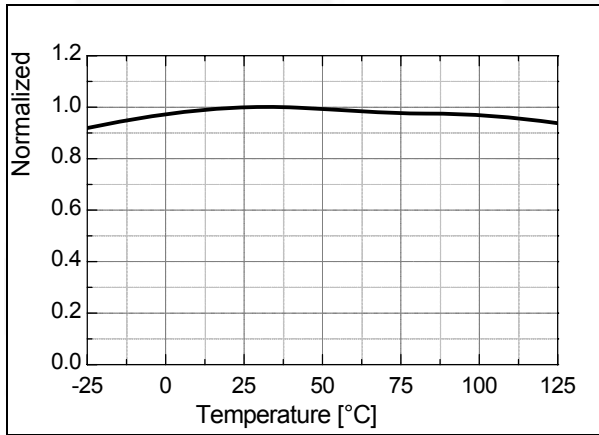

Figure 12. Shutdown Delay Current ( $I_{DELAY}$ ) vs.  $T_A$

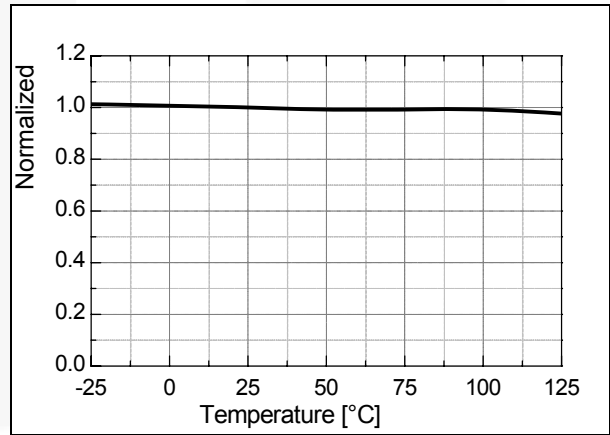

Figure 13. Burst-Mode HIGH Threshold Voltage ( $V_{BURH}$ ) vs.  $T_A$

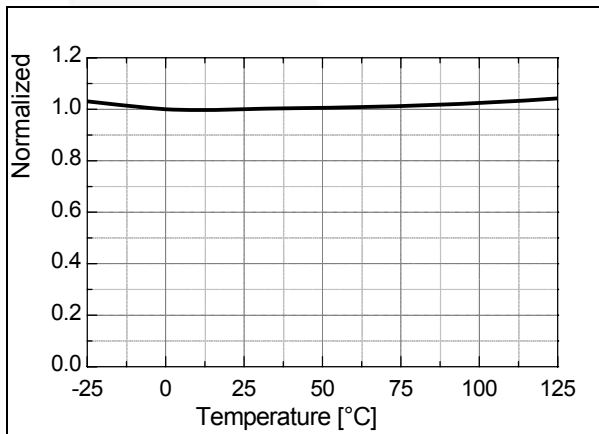

Figure 14. Burst-Mode LOW Threshold Voltage ( $V_{BURL}$ ) vs.  $T_A$

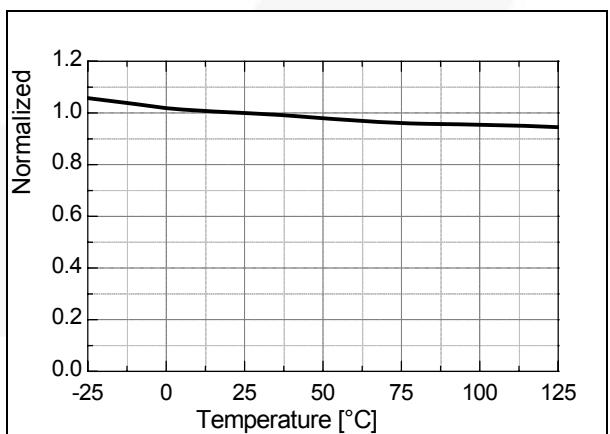
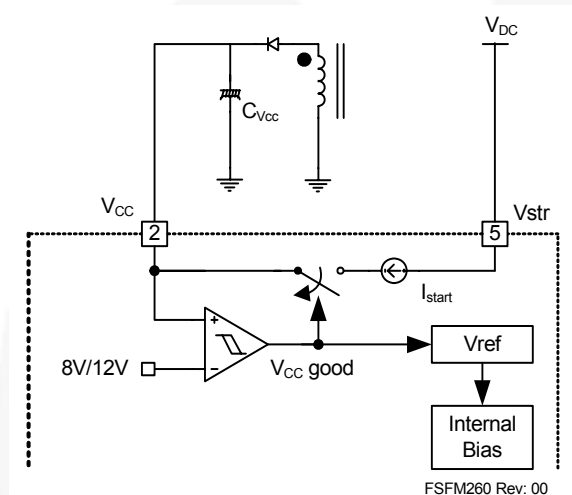

Figure 15. Peak Current Limit ( $I_{LIMIT}$ ) vs.  $T_A$

## Functional Description

**1. Startup:** In previous generations of Fairchild Power Switches (FPS™), the V<sub>CC</sub> pin had an external startup resistor to the DC input voltage line. In this generation, the startup resistor is replaced by an internal high-voltage current source. At startup, an internal high-voltage current source supplies the internal bias and charges the external capacitor (C<sub>VCC</sub>) connected to the V<sub>CC</sub> pin, as illustrated in Figure 16. When V<sub>CC</sub> reaches 12V, the FSFM260/261/300 begins switching and the internal high-voltage current source is disabled. Then, the FSFM260/261/300 continues its normal switching operation and the power is supplied from the auxiliary transformer winding unless V<sub>CC</sub> goes below the stop voltage of 8V.



**Figure 16. Internal Startup Circuit**

**2. Feedback Control:** FSFM260/261/300 employs current-mode control, as shown in Figure 17. An optocoupler (such as the FOD817A) and shunt regulator (such as the KA431) are typically used to implement the feedback network. Comparing the feedback voltage with the voltage across the R<sub>SENSE</sub> resistor makes it possible to control the switching duty cycle. When the reference pin voltage of the shunt regulator exceeds the internal reference voltage of 2.5V, the opto coupler LED current increases, pulling down the feedback voltage and reducing the duty cycle. This typically occurs when the input voltage is increased or the output load is decreased.

**2.1 Pulse-by-Pulse Current Limit:** Because current-mode control is employed, the peak current through the SenseFET is determined by the inverting input of the PWM comparator (V<sub>FB\*</sub>), as shown in Figure 17. When the current through the opto-transistor is zero and the current limit pin (#4) is left floating, the feedback current source (I<sub>FB</sub>) of 0.9mA flows only through the internal resistor (R+2.5R=2.8k). In this case, the cathode voltage of diode D2 and the peak drain current have maximum

values of 2.5V and 1.5A, respectively. The pulse-by-pulse current limit can be adjusted using a resistor to GND on the current limit pin (#4). The current limit level using an external resistor (R<sub>LIM</sub>) is given by:

$$I_{LIM} = \frac{R_{LIM} \cdot I_{LIM\_SPEC}}{2.8k\Omega + R_{LIM}} \quad (1)$$

$$\Rightarrow R_{LIM} = \frac{I_{LIM} \cdot 2.8k\Omega}{I_{LIM\_SPEC} - I_{LIM}} \quad (2)$$

where, I<sub>LIM</sub> is the desired drain current limit.

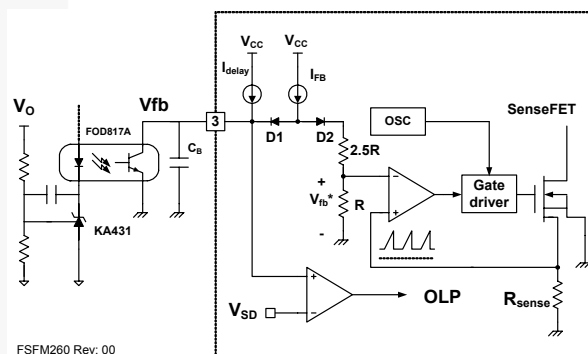

**Figure 17. Pulse Width Modulation (PWM) Circuit**

**2.2 Leading-Edge Blanking (LEB):** At the instant the internal SenseFET is turned on, a high-current spike occurs through the SenseFET, caused by primary-side capacitance and secondary-side rectifier reverse recovery. Excessive voltage across the R<sub>SENSE</sub> resistor would lead to incorrect feedback operation in the current-mode PWM control. To counter this effect, the FSFM260/261/300 employs a leading edge blanking (LEB) circuit. This circuit inhibits the PWM comparator for a short time (t<sub>LEB</sub>) after the SenseFET is turned on.

**2.3 Constant Power Limit Circuit:** Due to the circuit delay of FPS, the pulse-by-pulse limit current increases a little bit when the input voltage increases. This means unwanted excessive power is delivered to the secondary side. To compensate, the auxiliary power compensation network in Figure 18 can be used. R<sub>LIM</sub> can adjust pulse-by-pulse current by absorbing internal current source (I<sub>FB</sub>: typical value is 0.9mA) depending on the ratio between resistors. With the suggested compensation circuit, additional current from I<sub>FB</sub> is absorbed more proportionally to the input voltage (V<sub>DC</sub>) and achieves constant power in wide input range. Choose R<sub>LIM</sub> for proper current to the application, then check the pulse-by-pulse current difference between minimum and maximum input voltage. To eliminate the difference (to gain constant power), R<sub>y</sub> can be calculated by:

$$R_y \cong \frac{I_{lim\_spec} \times V_{dc} \times \frac{N_a}{N_p}}{I_{fb} \times \Delta I_{lim\_comp}} \quad (3)$$

where,  $I_{lim\_spec}$  is the limit current stated on the specification;  $N_a$  and  $N_p$  are the number of turns for  $V_{CC}$  and primary side, respectively;  $I_{fb}$  is the internal current source at feedback pin with a typical value of 0.9mA; and  $\Delta I_{lim\_comp}$  is the current difference that must be eliminated. In case of capacitor in the circuit  $1\mu F$ , 100V is good choice for all applications.

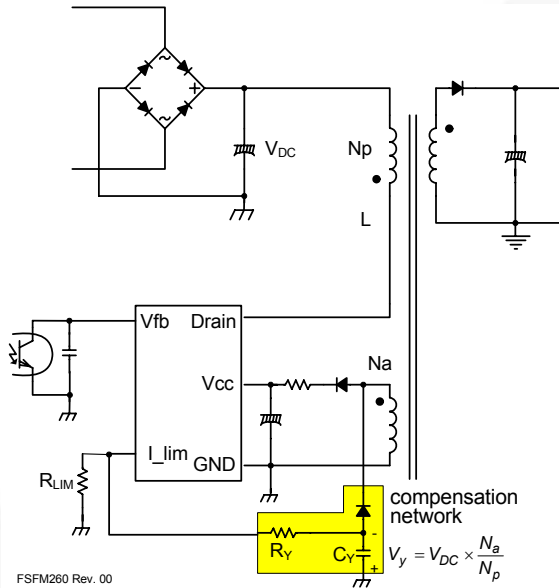

**Figure 18. Constant Power Limit Circuit**

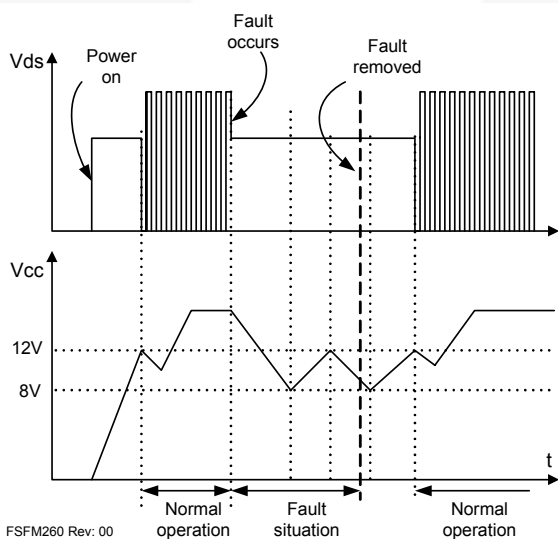
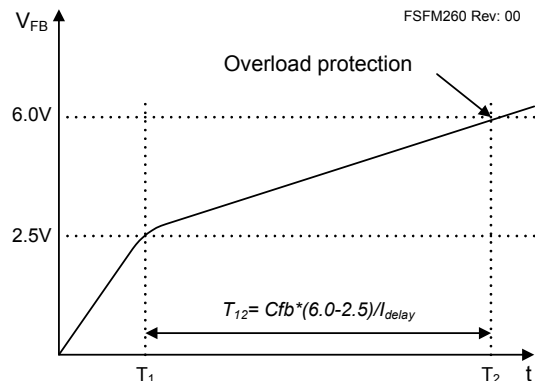

**Figure 19. Auto Restart Operation**

**3. Protection Circuit:** The FSFM260/261/300 has several self protective functions, such as overload protection (OLP), over-voltage protection (OVP), and thermal shutdown (TSD). Because these protection circuits are fully integrated into the IC without external

components, the reliability is improved without increasing cost. Once the fault condition occurs, switching is terminated and the SenseFET remains off. This causes  $V_{CC}$  to fall. When  $V_{CC}$  reaches the UVLO stop voltage, 8V, the protection is reset and the internal high-voltage current source charges the  $V_{CC}$  capacitor via the Vstr pin. When  $V_{CC}$  reaches the UVLO start voltage, 12V, the FSFM260/261/300 resumes normal operation. In this manner, the auto-restart can alternately enable and disable the switching of the power SenseFET until the fault condition is eliminated (see Figure 19).

**3.1 Overload Protection (OLP):** Overload is defined as the load current exceeding a pre-set level due to an unexpected event. In this situation, the protection circuit should be activated to protect the SMPS. However, even when the SMPS is in the normal operation, the overload protection circuit can be activated during the load transition. To avoid this undesired operation, the overload protection circuit is designed to be activated after a specified time to determine whether it is a transient situation or an overload situation. Because of the pulse-by-pulse current limit capability, the maximum peak current through the SenseFET is limited and, therefore the maximum input power is restricted with a given input voltage. If the output consumes beyond this maximum power, the output voltage ( $V_O$ ) decreases below the set voltage. This reduces the current through the opto-coupler LED, which also reduces the opto-coupler transistor current, increasing the feedback voltage ( $V_{FB}$ ). If  $V_{FB}$  exceeds 2.5V, D1 is blocked and the 5 $\mu A$  current source starts to charge  $C_B$  slowly up to  $V_{CC}$ . In this condition,  $V_{FB}$  continues increasing until it reaches 6V, when the switching operation is terminated, as shown in Figure 20. The delay time for shutdown is the time required to charge  $C_B$  from 2.5V to 6.0V with 5 $\mu A$ . In general, a 10 ~ 50ms delay time is typical for most applications.

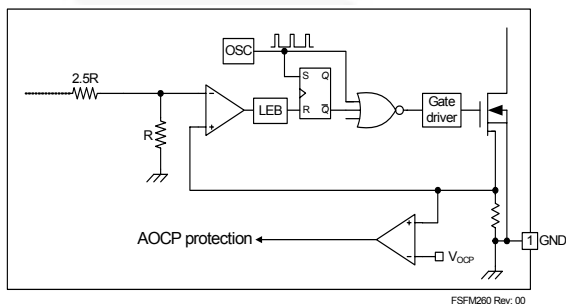

**Figure 20. Overload Protection**

**3.2 Over-Voltage Protection (OVP):** If the secondary side feedback circuit malfunctions or a solder defect causes an open in the feedback path, the current through the opto-coupler transistor becomes almost zero. Then,  $V_{FB}$  climbs up in a similar manner to the overload situation, forcing the preset maximum current to be supplied to the SMPS until the overload protection is activated. Because more energy than required is provided to the output, the output voltage may exceed the rated voltage before the overload protection is activated, resulting in the breakdown of the devices in the secondary side. To prevent this situation, an over-voltage protection (OVP) circuit is employed. In general,  $V_{CC}$  is proportional to the output voltage and the FSFM260/261/300 uses  $V_{CC}$  instead of directly monitoring the output voltage. If  $V_{CC}$  exceeds 19V, an OVP circuit is activated, terminating the switching operation. To avoid undesired activation of OVP during normal operation,  $V_{CC}$  should be designed below 19V.

**3.3 Thermal Shutdown (TSD):** The SenseFET and the control IC are built in one package. This allows for the control IC to detect the heat generation from the SenseFET. When the temperature exceeds approximately 140°C, the thermal shutdown is activated.

**3.4 Abnormal Over-Current Protection (AOCP):** When the secondary rectifier diodes or the transformer pins are shorted, a steep current with extremely high di/dt can flow through the SenseFET during the LEB time. Even though the FPS has overload protection, it is not enough to protect the FPS in those abnormal cases, since severe current stress is imposed on the SenseFET until OLP triggers. This IC has an internal AOCP circuit shown in Figure 21. When the gate turn-on signal is applied to the power SenseFET, the AOCP block is enabled and monitors the current through the sensing resistor. The voltage across the resistor is compared with a preset AOCP level. If the sensing resistor voltage is greater than the AOCP level, the set signal is applied to the latch, resulting in the shutdown of the SMPS.



**Figure 21. Abnormal Over-Current Protection**

**4. Soft-Start:** The FSFM260/261/300 has an internal soft-start circuit that increases PWM comparator inverting input voltage, together with the SenseFET current, slowly after it starts up. The typical soft-start time is 15ms. The pulse width to the power switching device is progressively increased to establish the correct working conditions for transformers, inductors, and capacitors. The voltage on the output capacitors is progressively increased to smoothly establish the required output voltage. It also helps prevent transformer saturation and reduce the stress on the secondary diode during startup.

**5. Burst Operation:** To minimize power dissipation in standby mode, the FSFM260/261/300 enters burst mode operation. As the load decreases, the feedback voltage decreases. As shown in Figure 22, the device automatically enters burst mode when the feedback voltage drops below  $V_{BURL}$  (350mV). At this point, switching stops and the output voltages start to drop at a rate dependent on standby current load. This causes the feedback voltage to rise. Once it passes  $V_{BURH}$  (500mV) switching resumes. The feedback voltage then falls and the process repeats. Burst mode operation alternately enables and disables switching of the power SenseFET, thereby reducing switching loss in standby mode.

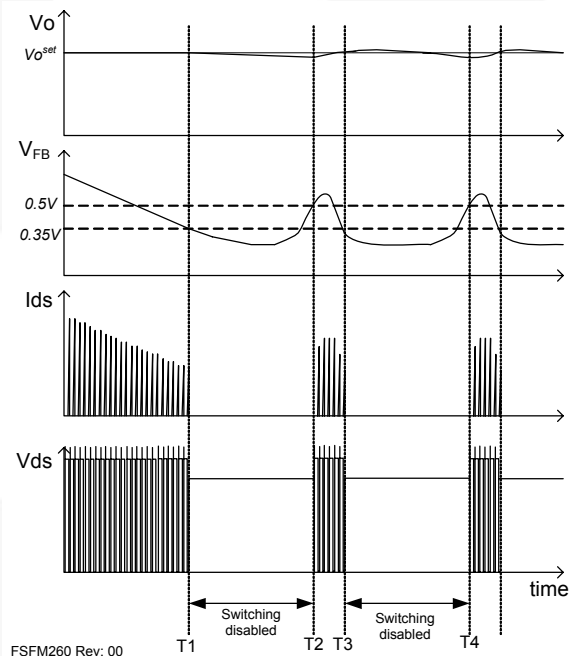

**Figure 22. Waveforms of Burst Operation**

## PCB Layout Guide

Due to the combined scheme, FPS shows better noise immunity than conventional PWM controller and MOSFET discrete solutions. Furthermore, internal drain current sense eliminates noise generation caused by a

sensing resistor. There are some recommendations for PCB layout to enhance noise immunity and suppress the noise inevitable in power-handling components.

There are typically two grounds in the conventional SMPS: power ground and signal ground. The power ground is the ground for primary input voltage and power, while the signal ground is ground for PWM controller. In FPS, those two grounds share the same pin, GND. Normally the separate grounds do not share the same trace and meet only at one point, the GND pin. More, wider patterns for both grounds are good for large currents by decreasing resistance.

Capacitors at the  $V_{CC}$  and FB pins should be as close as possible to the corresponding pins to avoid noise from the switching device. Sometimes Mylar® or ceramic capacitors with electrolytic for  $V_{CC}$  is better for smooth operation. The ground of these capacitors needs to connect to the signal ground not the power ground.

The cathode of the snubber diode should be close to the drain pin to minimize stray inductance. The Y-capacitor between primary and secondary should be directly connected to the power ground of DC link to maximize surge immunity.

Because the voltage range of feedback line is small, it is affected by the noise of the drain pin. Those traces should not draw across or close to the drain line.

In FSFM260/261/300, drain pins are the heat radiation pins, so wider PCB pattern is recommended to decrease the package temperature. Drain pins are also high voltage switching pins; however, too wide PCB pattern may deteriorate EMI immunity.

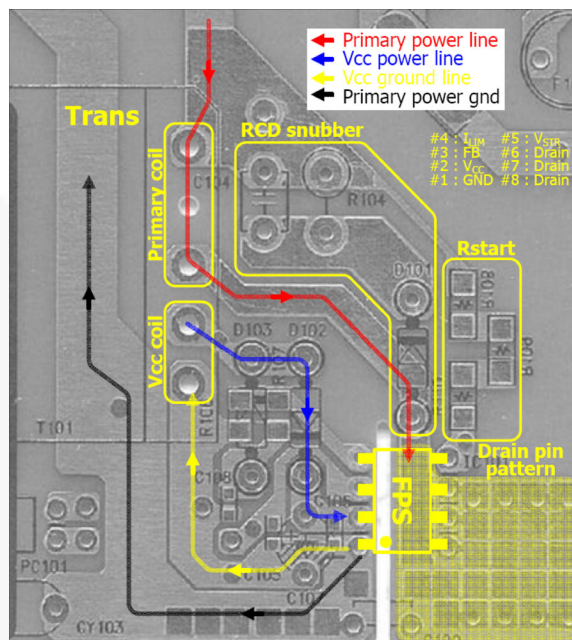

**Figure 23. Recommended PCB Layout**

Mylar® is a registered trademark of DuPont Teijin Films.

## Typical Application Circuit

Application	FPS™ Device	Input Voltage Range	Rated Output Power	Output Voltage (Maximum Current)
LCD Monitor Power Supply	FSFM300N	85-265V <sub>AC</sub>	30W	5.0V (2.0A) 14V (1.4A)

### Features

- Average efficiency of 25%, 50%, 75%, and 100% load conditions is higher than 80% at universal input
- Low standby mode power consumption (<1W at 230V<sub>AC</sub> input and 0.5W load)
- Enhanced system reliability through various protection functions
- Internal soft-start (15ms)

### Key Design Notes

- The delay time for overload protection is designed to be about 23ms with C105 of 33nF. If faster/slower triggering of OLP is required, C105 can be changed to a smaller/larger value (e.g. 100nF for 70ms).
- The SMD-type 100nF capacitor must be placed as close as possible to V<sub>CC</sub> pin to avoid malfunction by abrupt pulsating noises and to improve surge immunity.

### 1. Schematic

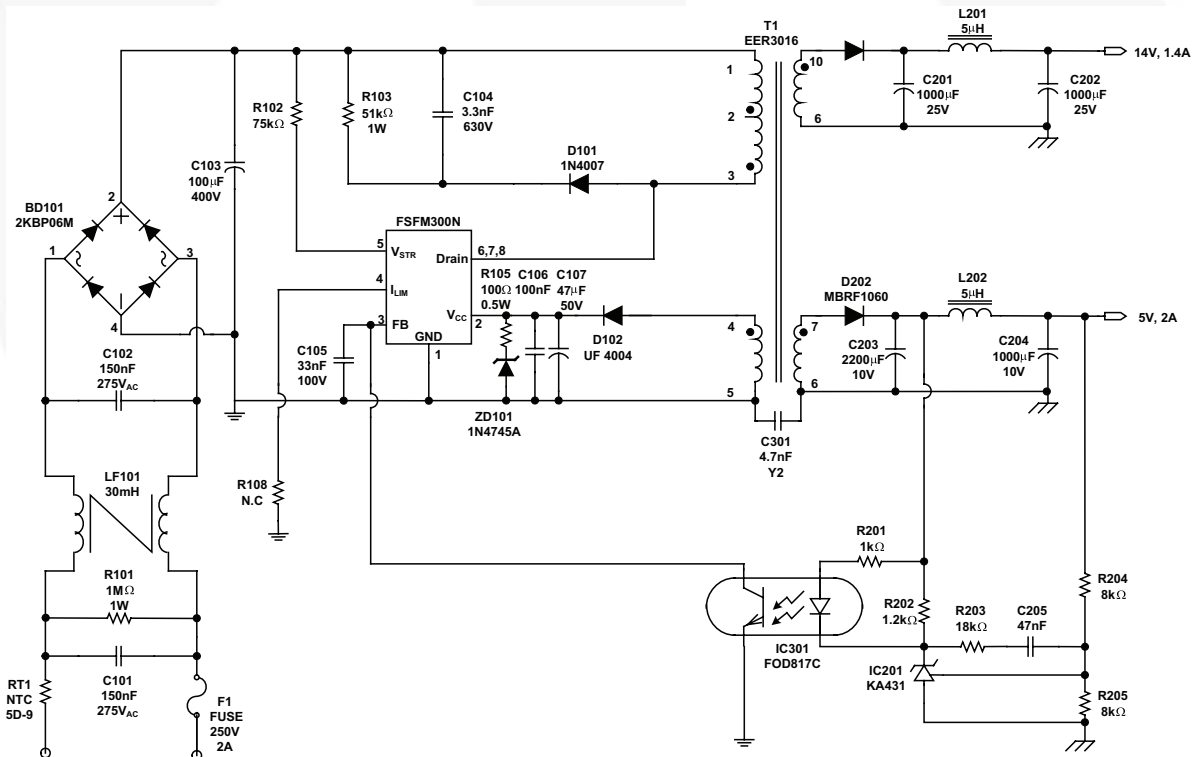

Figure 24. Demonstration Circuit of FSFM300N

## 2. Transformer

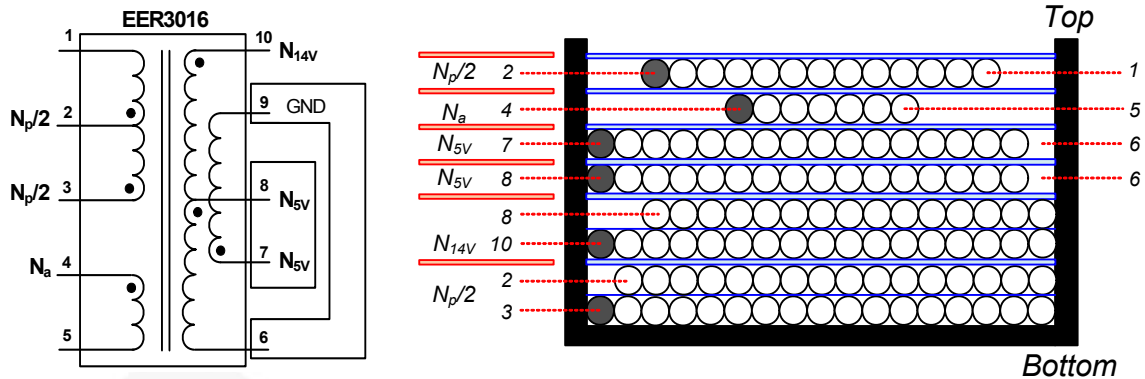

Figure 25. Transformer Schematic Diagram

## 3. Winding Specification

Position	No	Pin (s→f)	Wire	Turns	Winding Method
Bottom	$N_p/2$	3 → 2	$0.25\phi \times 1$	30	Two-Layer Solenoid Winding
	Insulation: Polyester Tape $t = 0.025\text{mm}$ , Three Layers				
	$N_{14V}$	10 → 8	$0.4\phi \times 2(\text{TIW})$	5	Solenoid Winding
	Insulation: Polyester Tape $t = 0.025\text{mm}$ , Three Layers				
	$N_{5V}$	8 → 6	$0.4\phi \times 3(\text{TIW})$	3	Solenoid Winding
	Insulation: Polyester Tape $t = 0.025\text{mm}$ , Three Layers				
	$N_{5V}$	7 → 6	$0.4\phi \times 3(\text{TIW})$	3	Solenoid Winding
	Insulation: Polyester Tape $t = 0.025\text{mm}$ , Three Layers				
	$N_a$	7 → 6	$0.15\phi \times 1$	7	Center Solenoid Winding
Top	Insulation: Polyester Tape $t = 0.025\text{mm}$ , Three Layers				
	$N_p/2$	2 → 1	$0.25\phi \times 1$	19	Center Solenoid Winding
Insulation: Polyester Tape $t = 0.025\text{mm}$ , Two Layers					

## 4. Electrical Characteristics

	Pin	Specification	Remarks
Inductance	1 - 3	$1.2\text{mH} \pm 10\%$	67kHz, 1V
Leakage	1 - 3	15 $\mu\text{H}$ Maximum	Short all other pins

## 5. Core & Bobbin

- Core: EER3016 ( $A_e=109.7\text{mm}^2$ )
- Bobbin: EER3016

## 6. Evaluation Board Part List

Part	Value	Note	Part	Value	Note
<b>Resistor</b>			<b>Inductor</b>		
R101	1MΩ	1W	L201	5μH	5A Rating
R102	75kΩ	1/2W	L202	5μH	5A Rating
R103	51kΩ	1W	<b>Diode</b>		
R105	100Ω	1/4W	D101	IN4007	1A, 1000V General-Purpose Rectifier
R108	10kΩ	1/4W	D102	UF4004	1A, 400V Ultrafast Rectifier
R201	1kΩ	1/4W	ZD101	1N4745A	1W 16V Zener Diode (optional)
R202	1.2kΩ	1/4W	D201	MBRF10H100	10A, 100V Schottky Rectifier
R203	18kΩ	1/4W	D202	MBRF1060	10A, 60V Schottky Rectifier
R204	8kΩ	1/4W	<b>IC</b>		
R205	8kΩ	1/4W	IC101	FSFM300N	FPS™
<b>Capacitor</b>			IC201	KA431 (TL431)	Voltage Reference
C101	150nF/275V <sub>AC</sub>	Box Capacitor	IC202	FOD817A	Opto-Coupler
C102	150nF/275V <sub>AC</sub>	Box Capacitor	<b>Fuse</b>		
C103	100μF/400V	Electrolytic Capacitor	Fuse	2A/250V	
C104	3.3nF/630V	Film Capacitor	<b>NTC</b>		
C105	33nF/50V	Ceramic Capacitor	RT101	5D-9	
C106	100nF/50V	SMD (1206)	<b>Bridge Diode</b>		
C107	47μF/50V	Electrolytic Capacitor	BD101	2KBP06M2N257	Bridge Diode
C201	1000μF/25V	Low-ESR Electrolytic Capacitor	<b>Line Filter</b>		
C202	1000μF/25V	Low-ESR Electrolytic Capacitor	LF101	34mH	
C203	2200μF/10V	Low-ESR Electrolytic Capacitor	<b>Transformer</b>		
C204	1000μF/10V	Low-ESR Electrolytic Capacitor	T1	EER3016	Ae=109.7mm <sup>2</sup>
C205	47nF/50V	Ceramic Capacitor			
C301	4.7nF/1kV	Ceramic Capacitor			

## Package Dimensions

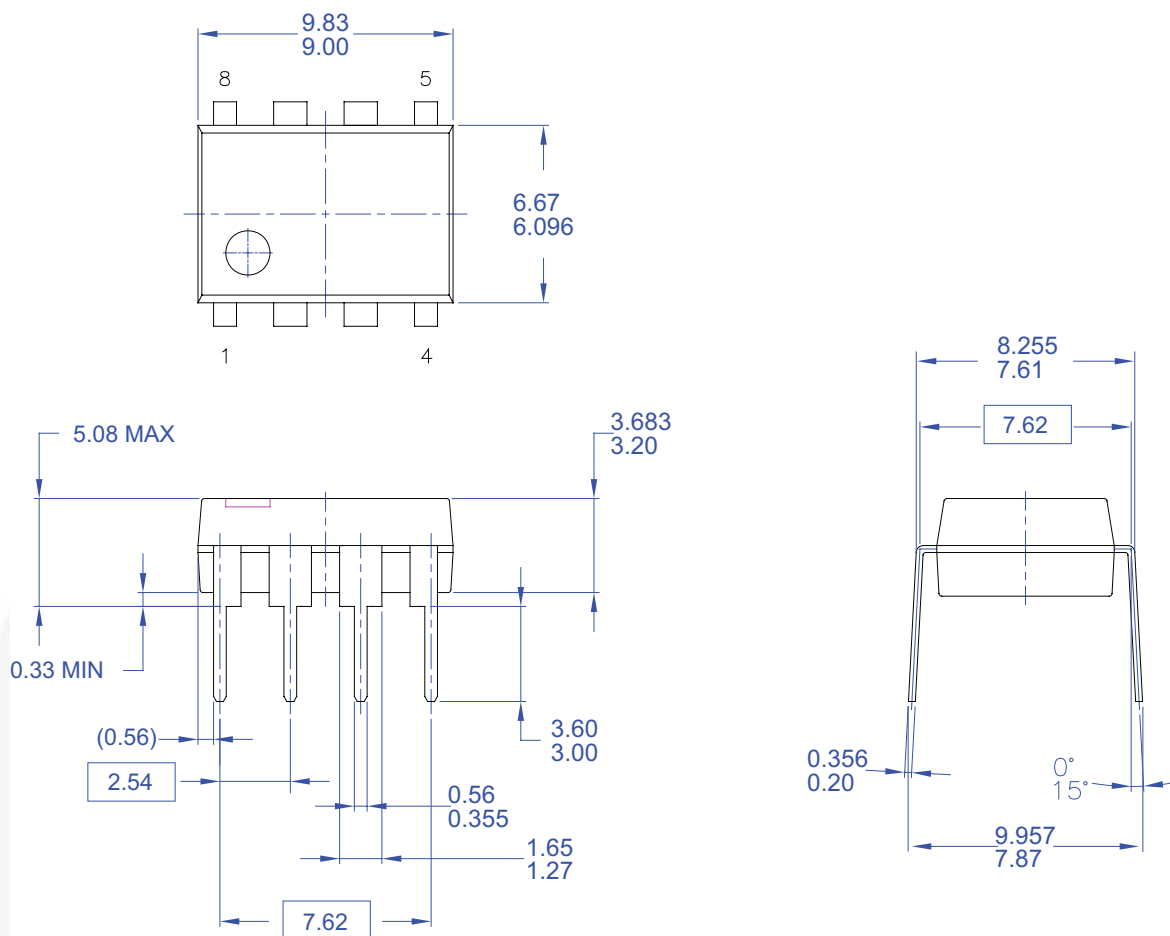

### NOTES: UNLESS OTHERWISE SPECIFIED

- A) THIS PACKAGE CONFORMS TO JEDEC MS-001 VARIATION BA
- B) ALL DIMENSIONS ARE IN MILLIMETERS.
- C) DIMENSIONS ARE EXCLUSIVE OF BURRS, MOLD FLASH, AND TIE BAR EXTRUSIONS.
- D) DIMENSIONS AND TOLERANCES PER ASME Y14.5M-1994
- E) DRAWING FILENAME AND REVISION: MKT-N08FREV2.

**Figure 26. 8-Lead Dual In-line Package (DIP)**

Package drawings are provided as a service to customers considering Fairchild components. Drawings may change in any manner without notice. Please note the revision and/or date on the drawing and contact a Fairchild Semiconductor representative to verify or obtain the most recent revision. Package specifications do not expand the terms of Fairchild's worldwide terms and conditions, specifically the warranty therein, which covers Fairchild products.

Always visit Fairchild Semiconductor's online packaging area for the most recent package drawings:  
<http://www.fairchildsemi.com/packaging/>



**TRADEMARKS**

The following includes registered and unregistered trademarks and service marks, owned by Fairchild Semiconductor and/or its global subsidiaries, and is not intended to be an exhaustive list of all such trademarks.

- |                          |                                     |                                       |                      |
|--------------------------|-------------------------------------|---------------------------------------|----------------------|
| AccuPower™               | FPST™                               | PowerTrench®                          | The Power Franchise® |
| Auto-SPM™                | F-PFST™                             | PowerXS™                              |                      |
| Build it Now™            | FRFET®                              | Programmable Active Droop™            | TinyBoost™           |
| CorePLUSTM               | Global Power Resource <sup>SM</sup> | QFET®                                 | TinyBuck™            |
| CorePOWER™               | Green FPS™                          | QST™                                  | TinyCalc™            |
| CROSSVOLT™               | Green FPS™ e-Series™                | Quiet Series™                         | TinyLogic™           |
| CTL™                     | Gmax™                               | RapidConfigure™                       | TINYOPTO™            |
| Current Transfer Logic™  | GTO™                                |                                       | TinyPower™           |
| EcoSPARK®                | IntelliMAX™                         | Saving our world, 1mW/W/kW at a time™ | TinyPWM™             |
| EfficientMax™            | ISOPLANAR™                          | SignalWise™                           | TinyWire™            |
| EZSWITCH™                | MegaBuck™                           | SmartMax™                             | TriFault Detect™     |
|                          | MICROCOPPLER™                       | SMART START™                          | TRUECURRENT™         |
|                          | MicroFET™                           | SPM®                                  | µSerDes™             |
| Fairchild®               | MicroPak™                           | STEALTH™                              |                      |
| Fairchild Semiconductor® | MillerDrive™                        | SuperFET™                             | UHC®                 |
| FACT Quiet Series™       | MotionMax™                          | SuperSOT™.3                           | Ultra FRFET™         |
| FACT®                    | Motion-SPM™                         | SuperSOT™.6                           | UniFET™              |
| FAST®                    | OPTOLOGIC®                          | SuperSOT™.8                           | VCX™                 |
| FastvCore™               | OPTOPLANAR®                         | SupreMOS™                             | VisualMax™           |
| FETBench™                |                                     | SyncFET™                              | XST™                 |
| FlashWriter®             | PDP SPM™                            | Sync-Lock™                            |                      |
|                          | Power-SPM™                          |                                       |                      |

\* Trademarks of System General Corporation, used under license by Fairchild Semiconductor.

**DISCLAIMER**

FAIRCHILD SEMICONDUCTOR RESERVES THE RIGHT TO MAKE CHANGES WITHOUT FURTHER NOTICE TO ANY PRODUCTS HEREIN TO IMPROVE RELIABILITY, FUNCTION, OR DESIGN. FAIRCHILD DOES NOT ASSUME ANY LIABILITY ARISING OUT OF THE APPLICATION OR USE OF ANY PRODUCT OR CIRCUIT DESCRIBED HEREIN; NEITHER DOES IT CONVEY ANY LICENSE UNDER ITS PATENT RIGHTS, NOR THE RIGHTS OF OTHERS. THESE SPECIFICATIONS DO NOT EXPAND THE TERMS OF FAIRCHILD'S WORLDWIDE TERMS AND CONDITIONS, SPECIFICALLY THE WARRANTY THEREIN, WHICH COVERS THESE PRODUCTS.

**LIFE SUPPORT POLICY**

FAIRCHILD'S PRODUCTS ARE NOT AUTHORIZED FOR USE AS CRITICAL COMPONENTS IN LIFE SUPPORT DEVICES OR SYSTEMS WITHOUT THE EXPRESS WRITTEN APPROVAL OF FAIRCHILD SEMICONDUCTOR CORPORATION.

As used herein:

- Life support devices or systems are devices or systems which, (a) are intended for surgical implant into the body or (b) support or sustain life, and (c) whose failure to perform when properly used in accordance with instructions for use provided in the labeling, can be reasonably expected to result in a significant injury of the user.
- A critical component in any component of a life support, device, or system whose failure to perform can be reasonably expected to cause the failure of the life support device or system, or to affect its safety or effectiveness.

**ANTI-COUNTERFEITING POLICY**

Fairchild Semiconductor Corporation's Anti-Counterfeiting Policy. Fairchild's Anti-Counterfeiting Policy is also stated on our external website, [www.fairchildsemi.com](http://www.fairchildsemi.com), under Sales Support.

Counterfeiting of semiconductor parts is a growing problem in the industry. All manufacturers of semiconductor products are experiencing counterfeiting of their parts. Customers who inadvertently purchase counterfeit parts experience many problems such as loss of brand reputation, substandard performance, failed applications, and increased cost of production and manufacturing delays. Fairchild is taking strong measures to protect ourselves and our customers from the proliferation of counterfeit parts. Fairchild strongly encourages customers to purchase Fairchild parts either directly from Fairchild or from Authorized Fairchild Distributors who are listed by country on our web page cited above. Products customers buy either from Fairchild directly or from Authorized Fairchild Distributors are genuine parts, have full traceability, meet Fairchild's quality standards for handling and storage and provide access to Fairchild's full range of up-to-date technical and product information. Fairchild and our Authorized Distributors will stand behind all warranties and will appropriately address any warranty issues that may arise. Fairchild will not provide any warranty coverage or other assistance for parts bought from Unauthorized Sources. Fairchild is committed to combat this global problem and encourage our customers to do their part in stopping this practice by buying direct or from authorized distributors.

**PRODUCT STATUS DEFINITIONS**

**Definition of Terms**

Datasheet Identification	Product Status	Definition
Advance Information	Formative / In Design	Datasheet contains the design specifications for product development. Specifications may change in any manner without notice.
Preliminary	First Production	Datasheet contains preliminary data; supplementary data will be published at a later date. Fairchild Semiconductor reserves the right to make changes at any time without notice to improve design.
No Identification Needed	Full Production	Datasheet contains final specifications. Fairchild Semiconductor reserves the right to make changes at any time without notice to improve the design.
Obsolete	Not In Production	Datasheet contains specifications on a product that is discontinued by Fairchild Semiconductor. The datasheet is for reference information only.

Rev. I42

# AMEYA360

## Components Supply Platform

Authorized Distribution Brand :



Website :

Welcome to visit [www.ameya360.com](http://www.ameya360.com)

Contact Us :

➤ Address :

401 Building No.5, JiuGe Business Center, Lane 2301, Yishan Rd  
Minhang District, Shanghai , China

➤ Sales :

Direct +86 (21) 6401-6692

Email [amall@ameya360.com](mailto:amall@ameya360.com)

QQ 800077892

Skype [ameyasales1](#) [ameyasales2](#)

➤ Customer Service :

Email [service@ameya360.com](mailto:service@ameya360.com)

➤ Partnership :

Tel +86 (21) 64016692-8333

Email [mkt@ameya360.com](mailto:mkt@ameya360.com)