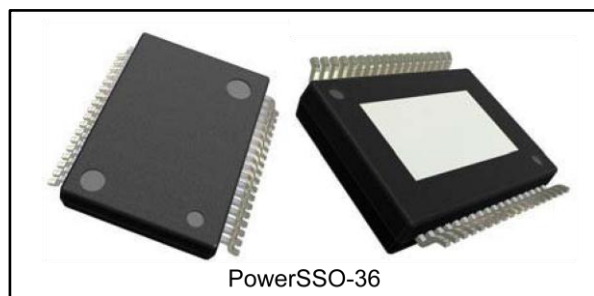


## Octal high-side smart power solid-state relay with serial/parallel selectable interface on-chip

Datasheet - production data



### Features

Type	$V_{\text{demag}}^{(1)}$	$R_{\text{DS(on)}}^{(1)}$	$I_{\text{OUT}}^{(1)}$	$V_{\text{CC}}$
VNI8200XP	$V_{\text{CC}}-45\text{ V}$	$0.11\ \Omega$	$0.7\text{ A}$	$45\text{ V}$

#### Notes:

<sup>(1)</sup>Per channel

- Output current: 0.7 A per channel
- Serial/parallel selectable interface
- Short-circuit protection
- 8-bit and 16-bit SPI interface for IC command and control diagnostic
- Channel overtemperature detection and protection
- Thermal independence of separate channels
- All type of loads (resistive, capacitive, inductive load) are driven
- Loss of GND protection

- Power Good diagnostic
- Undervoltage shutdown with hysteresis
- Overvoltage protection ( $V_{\text{CC}}$  clamping)
- Very low supply current
- Common fault open drain output
- IC warning temperature detection
- Channel output enable
- 100 mA high efficiency step-down switching regulator with integrated boot diode
- Adjustable regulator output
- Switching regulator disable
- 5 V and 3.3 V compatible I/Os
- Channel output status LED driving 4x2 multiplexed array
- Fast demagnetization of inductive loads
- ESD protection
- Designed to meet IEC61131-2, IEC61000-4-4, and IEC61000-4-5

### Applications

- Programmable logic control
- Industrial PC peripheral input/output
- Numerical control machines

Table 1: Device summary

Order code	Package	Packing
VNI8200XP	PowerSSO-36	Tube
VNI8200XPTR		Tape and reel

## Contents

<b>1</b>	<b>Description.....</b>	<b>6</b>
<b>2</b>	<b>Pin connection.....</b>	<b>8</b>
<b>3</b>	<b>Maximum ratings .....</b>	<b>10</b>
<b>4</b>	<b>Electrical characteristics .....</b>	<b>11</b>
	4.1 Power section.....	11
	4.2 SPI characteristics .....	12
	4.3 Switching.....	12
	4.4 Logic inputs.....	13
	4.5 Protection and diagnostic.....	13
	4.6 Step-down switching regulator .....	15
	4.7 LED driving array .....	15
<b>5</b>	<b>Reverse polarity protection .....</b>	<b>16</b>
<b>6</b>	<b>Demagnetization energy .....</b>	<b>17</b>
<b>7</b>	<b>Truth table.....</b>	<b>18</b>
<b>8</b>	<b>Pin function description.....</b>	<b>19</b>
	8.1 SPI/parallel selection mode (SEL2).....	19
	8.2 Serial data in (SDI).....	19
	8.3 Serial data out (SDO).....	19
	8.4 Serial data clock (CLK) .....	19
	8.5 Slave select ( $\overline{SS}$ ) .....	20
	8.6 8/16-bit selection (SEL1).....	20
	8.7 Output enable (OUT_EN).....	20
	8.8 IC warning case temperature detection ( $\overline{TWARN}$ ).....	21
	8.9 Fault indication ( $\overline{FAULT}$ ).....	21
	8.10 Power Good ( $\overline{PG}$ ) .....	22
	8.11 Programmable watchdog counter reset (WD) .....	22
<b>9</b>	<b>SPI operation (SEL2 = H) .....</b>	<b>24</b>
	9.1 8-bit SPI mode (SEL1 = L) .....	24
	9.2 16-bit SPI mode (SEL1 = H).....	24
<b>10</b>	<b>LED driving array .....</b>	<b>26</b>

---

<b>11</b>	<b>Step-down switching regulator .....</b>	<b>27</b>
<b>12</b>	<b>Typical circuits and conventions .....</b>	<b>28</b>
<b>13</b>	<b>Thermal management .....</b>	<b>31</b>
	13.1 Thermal behavior .....	32
<b>14</b>	<b>Interface timing diagram .....</b>	<b>33</b>
<b>15</b>	<b>Switching parameter test conditions .....</b>	<b>34</b>
<b>16</b>	<b>Package information .....</b>	<b>35</b>
	16.1 PowerSSO-36 package information .....	35
	16.2 PowerSSO-36 packing information .....	38
<b>17</b>	<b>Revision history .....</b>	<b>41</b>

## List of tables

Table 1: Device summary .....	1
Table 2: Pin description .....	8
Table 3: Absolute maximum ratings .....	10
Table 4: Thermal data .....	10
Table 5: Power section .....	11
Table 6: SPI characteristics .....	12
Table 7: Switching .....	12
Table 8: Logic inputs .....	13
Table 9: Protection and diagnostic .....	13
Table 10: Step-down switching regulator .....	15
Table 11: LED driving array .....	15
Table 12: Truth table .....	18
Table 13: Pin function description .....	19
Table 14: Programmable watchdog time .....	22
Table 15: Command 8-bit frame (master-to-slave) .....	24
Table 16: Fault 8-bit frame (slave-to-master) .....	24
Table 17: Command 16-bit frame (master-to-slave) .....	24
Table 18: Fault 16-bit frame (slave-to-master) .....	25
Table 19: PowerSSO-36 package mechanical data .....	37
Table 20: PowerSSO-36 tube shipment mechanical data .....	38
Table 21: PowerSSO-36 tape dimension mechanical data .....	39
Table 22: PowerSSO-36 reel dimension mechanical data .....	40
Table 23: Document revision history .....	41

## List of figures

Figure 1: Block diagram .....	7
Figure 2: Pin connection (top view) .....	8
Figure 3: Reverse polarity protection .....	16
Figure 4: Maximum demagnetization energy vs. load current, typical values .....	17
Figure 5: SPI mode diagram .....	20
Figure 6: Output channel enable/disable behavior .....	21
Figure 7: Power Good diagnostic .....	22
Figure 8: Watchdog reset .....	23
Figure 9: LED driving array .....	26
Figure 10: Typical circuit for switching regulation $V_{DC-out} = 3.3\text{ V}$ .....	28
Figure 11: Typical circuit for switching regulation $V_{DC-out} = 5\text{ V}$ .....	29
Figure 12: SPI directional logic convention .....	30
Figure 13: PowerSSO-36 thermal impedance vs. time .....	31
Figure 14: Thermal behavior .....	32
Figure 15: Serial timing .....	33
Figure 16: $dV/dt(ON)$ and $dV/dt(OFF)$ time diagram test conditions .....	34
Figure 17: $t_{d(ON)}$ and $t_{d(OFF)}$ time diagram test conditions .....	34
Figure 18: PowerSSO-36 package outline .....	35
Figure 19: PowerSSO-36 package outline details .....	36
Figure 20: PowerSSO-36 package outline details (section B-B) .....	36
Figure 21: PowerSSO-36 tube shipment outline .....	38
Figure 22: PowerSSO-36 tape dimension outline .....	39
Figure 23: PowerSSO-36 reel shipment outline .....	40

# 1 Description

The VNI8200XP is a monolithic 8-channel driver featuring a very low supply current, with integrated SPI interface and high efficiency 100 mA micropower step-down switching regulator peak current control loop mode. The IC, realized in STMicroelectronics™ VIPower™ technology, is intended to drive any kind of load with one side connected to ground.

Active channel current limitation combined with thermal shutdown, independent for each channel, and automatic restart, protect the device against overload.

Additional embedded functions are: loss of GND protection that automatically turns off the device outputs in case of ground disconnection, undervoltage shutdown with hysteresis, Power Good diagnostic for valid supply voltage range recognition, output enable function for immediate power outputs ON/OFF, and programmable watchdog function for microcontroller safe operation; case overtemperature protection to control the IC case temperature.

The device embeds a four-wire SPI serial peripheral with selectable 8 or 16-bit operations; through a select pin the device can also operate with a parallel interface.

Both the 8-bit and 16-bit SPI operations are compatible with daisy chain connection.

The SPI interface allows command of the output driver by enabling or disabling each channel featuring, in 16-bit format, a parity check control for communication robustness. It also allows the monitoring of the status of the IC signaling Power Good, overtemperature condition for each channel, IC pre-warning temperature detection.

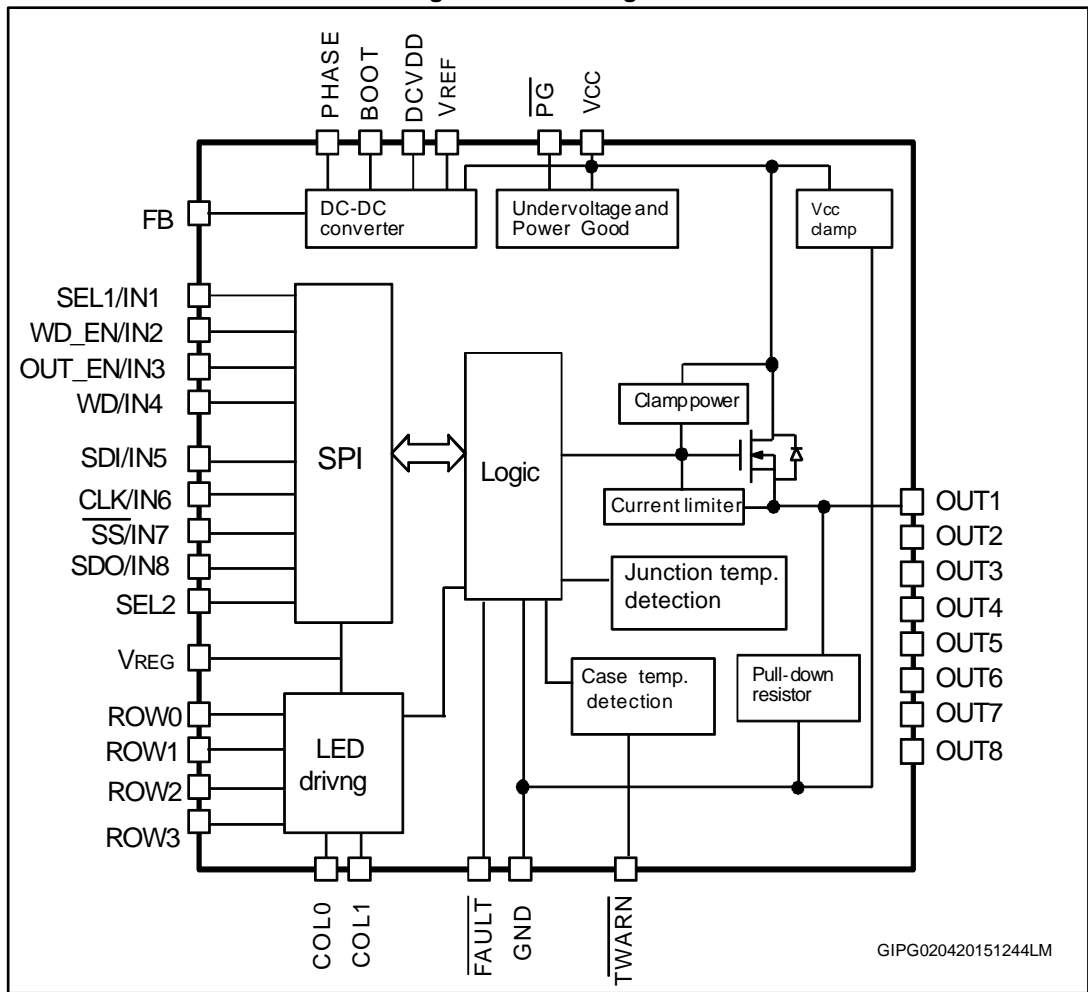
Built-in thermal shutdown protects the chip from overtemperature and short-circuit. In overload condition, the channel turns OFF and ON again automatically after the IC temperature decreases below a threshold fixed by a temperature hysteresis so that junction temperature is controlled. If this condition makes case temperature reaching case temperature limit,  $T_{CSD}$ , overloaded channels are turned OFF and restart, non-simultaneously, when case and junction temperature decrease below their own reset threshold. If the case of thermal reset, the channels loaded are not switched on until the junction temperature reset event. Non-overloaded channels continue to operate normally. Case temperature above  $T_{CSD}$  is reported through the  $\overline{TWARN}$  open drain pin.

An internal circuit provides a not latched common  $\overline{FAULT}$  indicator reporting if one of the following events occurs: channel OVT (overtemperature), parity check fail. The Power Good diagnostic warns the controller that the supply voltage is below a fixed threshold.

The watchdog function is used to detect the occurrence of a software fault of the host controller. The watchdog circuitry generates an internal reset on expiry of the internal watchdog timer. The watchdog timer reset can be achieved by applying a negative pulse on the WD pin. The watchdog function can be disabled by the WD\_EN dedicated pin. This pin also allows the programming of a wide range of watchdog timings.

An internal LED matrix driver circuitry (4 rows, 2 columns) allows the detection of the status of the single outputs. An integrated step-down voltage regulator provides supply voltage to the internal LED matrix driver and logic output buffers and can be used to supply the external optocouplers if the application requires isolation. The regulator is protected against short-circuit or overload conditions thanks to pulse-by-pulse current limit with a peak current control loop.

Figure 1: Block diagram



GIPG020420151244LM

## 2 Pin connection

Figure 2: Pin connection (top view)

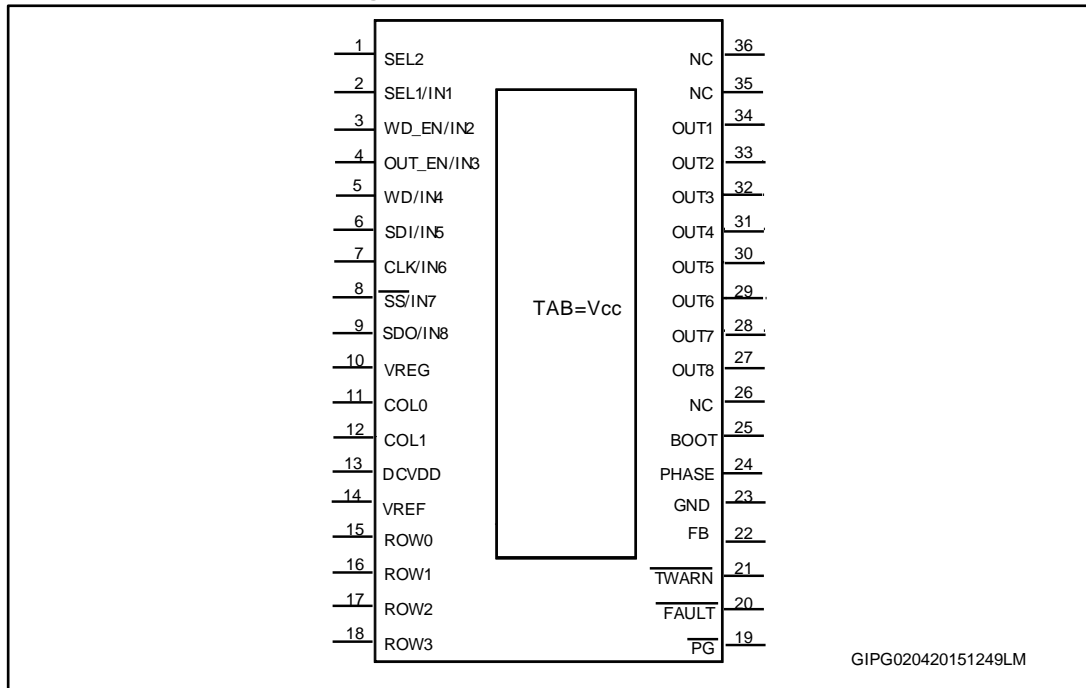


Table 2: Pin description

Pin	Name	Type	Description
1	SEL2	Logic input	SPI/parallel selection mode
2	SEL1/IN1	Logic input	8/16-bit SPI selection mode/channel 1 input
3	WD_EN/ IN2	Logic/analog input	Watchdog enable_setting/channel 2 input
4	OUT_EN /IN3	Logic input	Output enable/channel 3 input
5	WD/IN4	Logic input	Watchdog input. The internal watchdog counter is cleared on the falling edges/channel 4 input
6	SDI/IN5	Logic input	Serial data input/channel 5 input
7	CLK/IN6	Logic input	Serial clock/channel 6 input
8	$\overline{SS}$ /IN7	Logic input	Slave select/channel 7 input
9	SDO/IN8	Logic input/output	Serial data output/channel 8 input
10	VREG	Power supply	SPI/inputs/LED supply voltage
11	COL0	Open source output	LED source output
12	COL1	Open source output	LED source output
13	DCVDD	Analog output	Internally generated DC-DC low voltage supply (to be connected to external 10 nF capacitor)



Pin	Name	Type	Description
14	VREF	Analog output	Internally generated DC-DC voltage reference (to be connected to external 10 nF capacitor)
15	ROW0	Open drain output	Status channel 1-2
16	ROW1	Open drain output	Status channel 3-4
17	ROW2	Open drain output	Status channel 5-6
18	ROW3	Open drain output	Status channel 7-8
19	$\overline{\text{PG}}$	Open drain output	Power Good diagnostic, active low
20	$\overline{\text{FAULT}}$	Open drain output	Fault indication, active low
21	$\overline{\text{TWARN}}$	Open drain output	IC case warning temperature detection, active low
22	FB	Analog input	Step-down feedback input. The output voltage, directly connected to this pin, results in an output voltage of 3.3 V. An external resistor divider is required for higher output voltages
23	GND		Ground
24	PHASE	Power output	Step-down output
25	BOOT	Power output	Step-down bootstrap voltage. Used to provide a drive voltage, higher than the supply voltage, to power the switch of the step-down regulator
26	NC		Not connected
27	OUT8	Power output	Channel 8 power output
28	OUT7	Power output	Channel 7 power output
29	OUT6	Power output	Channel 6 power output
30	OUT5	Power output	Channel 5 power output
31	OUT4	Power output	Channel 4 power output
32	OUT3	Power output	Channel 3 power output
33	OUT2	Power output	Channel 2 power output
34	OUT1	Power output	Channel 1 power output
35	NC		Not connected
36	NC		Not connected
TAB	TAB	Power supply	Exposed tab internally connected to V <sub>CC</sub>

### 3 Maximum ratings

Table 3: Absolute maximum ratings

Symbol	Parameter	Value	Unit
$V_{CC}$	Power supply voltage	45	V
$-V_{CC}$	Reverse supply voltage	-0.3	V
$V_{REG}$	Logic supply voltage	-0.3 to +6	V
$V_{FAULT}$ $V_{TWARN}$ $V_{PG}$	Voltage range at pins $\overline{TWARN}$ , $\overline{FAULT}$ , $\overline{PG}$	-0.3 to +6	V
$V_{BOOT}$	Bootstrap peak voltage $V_{PHASE} = V_{CC}$	$V_{CC}+6$	V
$V_{ROW}$	Voltage range on ROW pins	-0.3 to +6	V
$V_{COL}$	Voltage range on COL pins	-0.3 to +6	V
$V_{dig}$	Voltage level range on logic input pins	-0.3 to +6	V
$I_{OUT}$	Output current (continuous)	Internally limited <sup>(1)</sup>	A
$I_R$	Reverse output current (per channel)	-5	A
$I_{GND}$	DC ground reverse current	-250	mA
$I_{REG}$	$V_{REG}$ input current	-1/10	mA
$I_{FAULT}$ $I_{TWARN}$ , $I_{PG}$	Current range on pins $\overline{TWARN}$ , $\overline{FAULT}$ , $\overline{PG}$	-1 to +10	mA
$I_{IN}$	Input current range	-1 to +10	mA
$I_{ROW}$	Current range on ROW pins (ROW in ON-state)	+20	mA
	Current range on ROW pins (ROW in OFF-state)	-1 to +10	mA
$I_{COL}$	Current range on COL pins (COL in ON-state)	-10	mA
	Current range on COL pins (COL in OFF-state)	-1 to +10	mA
$V_{ESD}$	Electrostatic discharge (R = 1.5 k $\Omega$ ; C = 100 pF)	2000	V
$E_{AS}$	Single pulse avalanche energy per channel not simultaneously @ $T_{amb} = 125^\circ$ , $I_{OUT} = 0.5$ A	3	J
$P_{TOT}$	Power dissipation at $T_C = 25^\circ\text{C}$	Internally limited <sup>(1)</sup>	W
$T_J$	Junction operating temperature	Internally limited	$^\circ\text{C}$
$T_{STG}$	Storage temperature	-55 to 150	$^\circ\text{C}$

**Notes:**

<sup>(1)</sup>Protection functions are intended to avoid IC damage in fault conditions and are not intended for continuous operation. Continuous and repetitive operation of protection functions may reduce the IC lifetime.

Table 4: Thermal data

Symbol	Parameter	Value	Unit
$R_{th(JC)}$	Thermal resistance junction-case <sup>(1)</sup>	Max. 2	$^\circ\text{C/W}$
$R_{th(JA)}$	Thermal resistance junction-ambient <sup>(2)</sup>	Max. 15	$^\circ\text{C/W}$

**Notes:**

<sup>(1)</sup>Per channel.

<sup>(2)</sup>PowerSSO-36 mounted on the STEVAL-IFP022V1 developed on four-layer FR4, with about 8 cm<sup>2</sup> for each layer.

## 4 Electrical characteristics

### 4.1 Power section

10.5 V < V<sub>CC</sub> < 36 V; -40 °C < T<sub>J</sub> < 125 °C; unless otherwise specified

Table 5: Power section

Symbol	Parameter	Test conditions	Min.	Typ.	Max.	Unit
V <sub>CC</sub>	Supply voltage		10.5		36	V
V <sub>CC</sub> clamp	Clamp on V <sub>CC</sub>	Current 20 mA	45	50	52	V
R <sub>DS(on)</sub>	On-state resistance	I <sub>OUT</sub> = 0.5 A at T <sub>J</sub> = 25 °C		0.11		Ω
		I <sub>OUT</sub> = 0.5 A			0.2	
I <sub>S</sub>	V <sub>CC</sub> supply current	All channels in OFF-state, DC-DC in OFF-state, V <sub>REG</sub> =5 V, SPI OFF <sup>(1)</sup>		1		mA
		All channels in ON-state, DC- DC in ON-state V <sub>REG</sub> = 5 V, SPI ON <sup>(2)</sup>		5.6		mA
I <sub>DS</sub>	V <sub>REG</sub> supply current	DC-DC OFF V <sub>REG</sub> = 5 V SPI OFF WD_EN = 0		200		μA
		DC/DC OFF V <sub>REG</sub> = 5 V SPI ON WD_EN = V <sub>REG</sub>		250		μA
I <sub>LGND</sub>	Output current at GND disconnection	All pins at 0 V except V <sub>OUT</sub> = 24 V			0.5	mA
V <sub>OUT(OFF)</sub>	OFF-state output voltage	V <sub>IN</sub> = 0 V, I <sub>OUT</sub> = 0 A			1	V
I <sub>OUT(OFF)</sub>	OFF-state output current	V <sub>IN</sub> = V <sub>OUT</sub> = 0 V	0		2	μA
F <sub>CP</sub>	Charge pump frequency	Channel in ON-state <sup>(3)</sup>		1.45		MHz

**Notes:**

<sup>(1)</sup>  $\overline{SS}$  signal high, no communication.

<sup>(2)</sup>  $\overline{SS}$  signal low, communication ON.

<sup>(3)</sup> To cover EN55022 class A and class B normative.

## 4.2 SPI characteristics

$10.5\text{ V} < V_{CC} < 36\text{ V}$ ;  $2.7\text{ V} < V_{REG} < 5\text{ V}$ ;  $-40 < T_J < 125\text{ }^\circ\text{C}$ ; unless otherwise specified

Table 6: SPI characteristics

Symbol	Parameter	Test conditions	Min.	Typ.	Max.	Unit
$f_{CLK}$	SPI clock frequency			-	5	MHz
$t_r(CLK)$ , $t_f(CLK)$	SPI clock rise/fall time			-	20	ns
$t_{su}(\overline{SS})$	$\overline{SS}$ setup time		120	-		ns
$t_h(\overline{SS})$	$\overline{SS}$ hold time		120	-		ns
$t_w(CLK)$	CLK high time		80	-		ns
$t_{su}(SDI)$	Data input setup time		100	-		ns
$t_h(SDI)$	Data input hold time		100	-		ns
$t_a(SDO)$	Data output access time			-	100	ns
$t_{dis}(SDO)$	Data output disable time			-	200	ns
$t_v(SDO)$	Data output valid time			-	100	ns
$t_h(SDO)$	Data output hold time		0	-		ns
$V_{SDO}$	Voltage on serial data output	$I_{SDO} = 15\text{ mA}$	$V_{REG} - 0.8$	-		V
		$I_{SDO} = -4\text{ mA}$		-	0.8	V

## 4.3 Switching

$V_{CC} = 24\text{ V}$ ;  $-40\text{ }^\circ\text{C} < T_J < 125\text{ }^\circ\text{C}$

Table 7: Switching

Symbol	Parameter	Test conditions	Min.	Typ.	Max.	Unit
$t_{d(ON)}$	Turn-ON delay time	$I_{OUT} = 0.5\text{ A}$ , resistive load, input rise time $< 0.1\text{ }\mu\text{s}$	-	5	-	$\mu\text{s}$
$t_r$	Rise time	$I_{OUT} = 0.5\text{ A}$ , resistive load, input rise time $< 0.1\text{ }\mu\text{s}$	-	5	-	$\mu\text{s}$
$t_{d(OFF)}$	Turn-OFF delay time	$I_{OUT} = 0.5\text{ A}$ , resistive load, input rise time $< 0.1\text{ }\mu\text{s}$	-	10	-	$\mu\text{s}$
$t_f$	Fall time	$I_{OUT} = 0.5\text{ A}$ , resistive load, input rise time $< 0.1\text{ }\mu\text{s}$	-	5	-	$\mu\text{s}$
$dV/dt_{(ON)}$	Turn-ON voltage slope	$I_{OUT} = 0.5\text{ A}$ , resistive load, input rise time $< 0.1\text{ }\mu\text{s}$	-	3	-	$\text{V}/\mu\text{s}$
$dV/dt_{(OFF)}$	Turn-OFF voltage slope	$I_{OUT} = 0.5\text{ A}$ , resistive load, input rise time $< 0.1\text{ }\mu\text{s}$	-	4	-	$\text{V}/\mu\text{s}$

## 4.4 Logic inputs

$10.5\text{ V} < V_{CC} < 36\text{ V}$ ;  $-40\text{ }^{\circ}\text{C} < T_J < 125\text{ }^{\circ}\text{C}$ ; unless otherwise specified

Table 8: Logic inputs

Symbol	Parameter	Test conditions	Min.	Typ.	Max.	Unit
$V_{IL}$	Input low level voltage				0.8	V
$V_{IH}$	Input high level voltage		2.20			V
$V_{I(HYST)}$	Input hysteresis voltage			0.15		V
$I_{IN}$	Input current	$V_{IN} = 5\text{ V}$	8			$\mu\text{A}$

## 4.5 Protection and diagnostic

$10.5\text{ V} < V_{CC} < 36\text{ V}$ ;  $-40\text{ }^{\circ}\text{C} < T_J < 125\text{ }^{\circ}\text{C}$ ; unless otherwise specified

Table 9: Protection and diagnostic

Symbol	Parameter	Test conditions	Min.	Typ.	Max.	Unit
$V_{PGH1}$	Power Good diagnostic ON threshold		16.6	17.5	18.4	V
$V_{PGH2}$	Power Good diagnostic OFF threshold		15.6	16.5	17.4	
$V_{PGHYS}$	Power Good diagnostic hysteresis			1		
$V_{USD}$	Undervoltage ON protection			9.5	10.5	V
	Undervoltage OFF protection			9		V
$V_{USDHYS}$	Undervoltage hysteresis		0.4	0.5		V
$V_{demag}$	Output voltage at turn-OFF	$I_{OUT} = 0.5\text{ A}$ ; $L_{LOAD} \geq 1\text{ mH}$	$V_{CC}-52$	$V_{CC}-50$	$V_{CC}-45$	V
$V_{TWARN}$	$\overline{\text{TWARN}}$ pin low-state output voltage	$I_{TWARN} = 3\text{ mA}$ (active condition)			0.6	V
$V_{FAULT}$	$\overline{\text{FAULT}}$ pin low-state output voltage	$I_{FAULT} = 3\text{ mA}$ (fault condition)			0.6	V
$V_{PG}$	$\overline{\text{PG}}$ pin low-state output voltage	$I_{PG} = 3\text{ mA}$ (active condition) $V_{REG} = 3.3\text{ V}$ $V_{CC} = 0$			0.7	V

Symbol	Parameter	Test conditions	Min.	Typ.	Max.	Unit
$I_{PEAK}$	Maximum DC output current before limitation			2.4		A
$I_{LIM}$	Short-circuit current limitation per channel	$R_{LOAD} = 0$ $V_{CC} = 24$ V $T_J = 25$ °C	0.7	1.1	1.7	A
Hyst	$I_{LIM}$ tracking limits	$R_{LOAD} = 0$		0.3		A
$I_{LFAULT}$	$\overline{FAULT}$ leakage current	$V_{pin} = 5$ V			2	$\mu$ A
$I_{TWARN}$	$\overline{TWARN}$ leakage current					
$I_{PG}$	$\overline{PG}$ leakage current					
$T_{TSD}$	Junction shutdown temperature		160	180		°C
$T_R$	Junction reset temperature			160		°C
$T_{HIST}$	Junction thermal hysteresis			20		°C
$T_{CSD}$	Case shutdown temperature		115	130	155	°C
$T_{CR}$	Case reset temperature			110		°C
$T_{CHYST}$	Case thermal hysteresis			20		°C
$t_{WD}$	Watchdog hold time	As per figure 8	50			ns
$t_{WM}$	Watchdog time	As per figure 8 and table 14				
$t_{OUT\_EN}$	OUT_EN pin propagation delay <sup>(1)</sup>	$V_{CC} = 24$ V $I_{OUT} = 72$ mA		10		us
$t_{res}$	OUT_EN hold time		50			ns
$t_{WO}$	Watchdog timeout <sup>(2)</sup>				$t_{WM} + t_{d(off)}$	ms

**Notes:**

<sup>(1)</sup>Time from reset active low and power out disable.

<sup>(2)</sup>The time from  $t_{WM}$  elapsed to power out disable.

## 4.6 Step-down switching regulator

$10.5\text{ V} < V_{CC} < 36\text{ V}$ ;  $-40\text{ }^{\circ}\text{C} < T_J < 125\text{ }^{\circ}\text{C}$ ; unless otherwise specified

Table 10: Step-down switching regulator

Symbol	Parameter	Test conditions	Min.	Typ.	Max.	Unit
$V_{DC\_out}$	Regulated output voltage	$I_{REG}$ from 0 to 100 mA $V_{REG}$ 3.3 V	3.1	3.3	3.5	V
		$I_{REG}$ from 0 to 100 mA $V_{REG}$ 5 V		5		
$V_{FB}$	Voltage feedback		3.1	3.3	3.5	V
$R_{DS(on)}$	MOSFET on-resistance			1.5		$\Omega$
$I_{lim}$	Limitation current		0.55		0.9	A
$I_{qop}$	Total operating quiescent current			0.6		mA
$I_{qst-by}$	Total standby quiescent current	Regulator standby		15.8		$\mu\text{A}$
$f_s$	Switching frequency			400		kHz
$D_{max}$	Maximum duty cycle			80%		%
$T_{onmin}$	Minimum on-time			150		ns
$f_{sc}$	Frequency in short-circuit condition			50		kHz

## 4.7 LED driving array

$10.5\text{ V} < V_{CC} < 36\text{ V}$ ;  $-40\text{ }^{\circ}\text{C} < T_J < 125\text{ }^{\circ}\text{C}$ ; unless otherwise specified

Table 11: LED driving array

Symbol	Parameter	Test conditions	Min.	Typ.	Max.	Unit
$V_{COL}$	Output source voltage on COL pins	Output current 0 to 7 mA	$V_{REG}-0.3$	$V_{REG}-0.2$		V
$V_{ROW}$	Open drain voltage on ROW pins	Output current 0 to 15 mA		0.2	0.3	V
$F_{sw}$	Row refresh frequency with duty=25%			780		Hz

## 5 Reverse polarity protection

Reverse polarity protection can be implemented on board using two different solutions:

1. Placing a resistor ( $R_{GND}$ ) between IC GND pin and load GND
2. Placing a diode between IC GND pin and load GND

If option 1 is selected, the minimum resistance value has to be selected according to the following equation:

$$R_{GND} \geq V_{CC} / I_{GND}$$

where  $I_{GND}$  is the DC reverse ground pin current and it can be found in section 4.

Power dissipated by  $R_{GND}$  (when  $V_{CC} < 0$ : during reverse polarity situations) is:

$$P_D = (V_{CC})^2 / R_{GND}$$

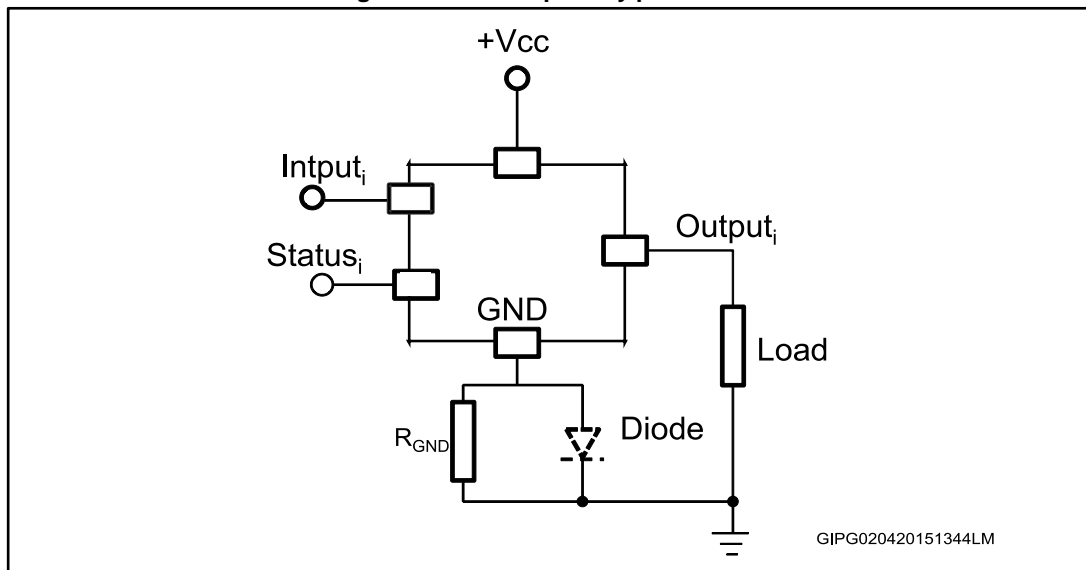
If option 2 is selected, the diode has to be chosen by taking into account  $V_{RRM} > |V_{CC}|$  and its power dissipation capability:

$$P_D \geq I_S * V_F$$



In normal conditions (no reverse polarity), due to the diode, there is a voltage drop between GND of the device and GND of the system.

Figure 3: Reverse polarity protection

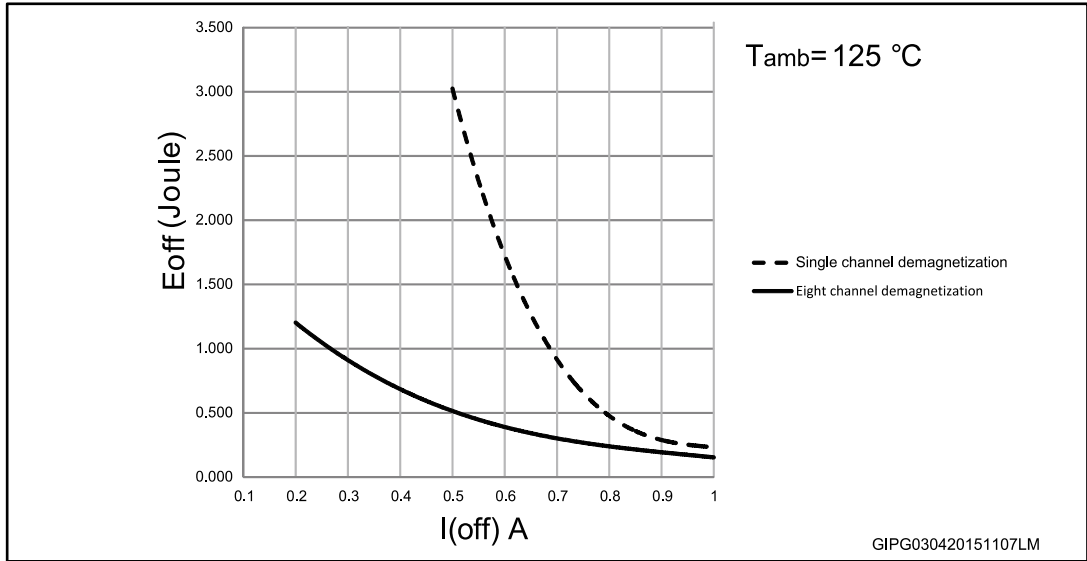


This schematic can be used with any type of load.



## 6 Demagnetization energy

Figure 4: Maximum demagnetization energy vs. load current, typical values



## 7 Truth table

Table 12: Truth table

Condition	Input	Output	SPI status bit	Fault	$\overline{\text{TWARN}}$	Power Good
Normal operation	High	On	Reset	High	High	High
	Low	Off	Reset	High	High	High
Junction overtemperature	High	Off	Set	Low	X	X
	Low	Off	Set <sup>(1)</sup>	High	X	X
Case overtemperature	High	Off	Set <sup>(1)</sup>	X	Low	X
	Low	Off	Set <sup>(1)</sup>	X	Low <sup>(1)</sup>	X
Undervoltage	High	Off	Reset	X	X	X
	Low	Off	Reset	X	X	X
Power Good	High	On	Set <sup>(2)</sup>	High	High	Low
	Low	Off	Set <sup>(2)</sup>	High	High	Low

**Notes:**

<sup>(1)</sup>This signal becomes high after the temperature falls below the reset threshold.

<sup>(2)</sup>If fault expires, the reset condition occurs after SPI communication, otherwise it is set again.

## 8 Pin function description

### 8.1 SPI/parallel selection mode (SEL2)

This pin allows the selection of the IC interfacing mode. The SPI interface is selected if SEL2 = H, while the parallel interface is selected if SEL2 = L, according to the below table:

Table 13: Pin function description

Pin	SEL2 = H <sup>(1)</sup>		SEL2 = L	
		SPI operation		parallel operation
SDO/IN8	SDO	Serial data output	IN8	Input to channel 8
$\overline{SS}$ /IN7	$\overline{SS}$	Slave select	IN7	Input to channel 7
CLK/IN6	CLK	Serial clock	IN6	Input to channel 6
SDI/IN5	SDI	Serial data input	IN5	Input to channel 5
WD/IN4	WD	Watchdog input	IN4	Input to channel 4
OUT_EN/IN3	OUT_EN	IC OUTPUT enable/disable	IN3	Input to channel 3
WD_EN/IN2	WD_EN	Watchdog enable/disable and timing preset	IN2	Input to channel 2
SEL1/IN1	SEL1	8/16-bit SPI selection mode	IN1	Input to channel 1

**Notes:**

<sup>(1)</sup>SEL2 has an internal weak pull-down.

### 8.2 Serial data in (SDI)

If SEL2 = H, this pin is the input of the serial control frame. SDI is read on CLK rising edges and, therefore, the microcontroller must change SDI state during the CLK falling edges.

After the  $\overline{SS}$  falling edge, the SDI is equal to the most significant bit of the control frame.

### 8.3 Serial data out (SDO)

If SEL2 = H, this pin is the output of the serial fault frame. SDO is updated on CLK falling edges and, therefore, the microcontroller must read SDO state during the CLK rising edges. The SDO pin is tri-stated when  $\overline{SS}$  signal is high and it is equal to the most

significant bit of the fault frame after the  $\overline{SS}$  falling edge.

### 8.4 Serial data clock (CLK)

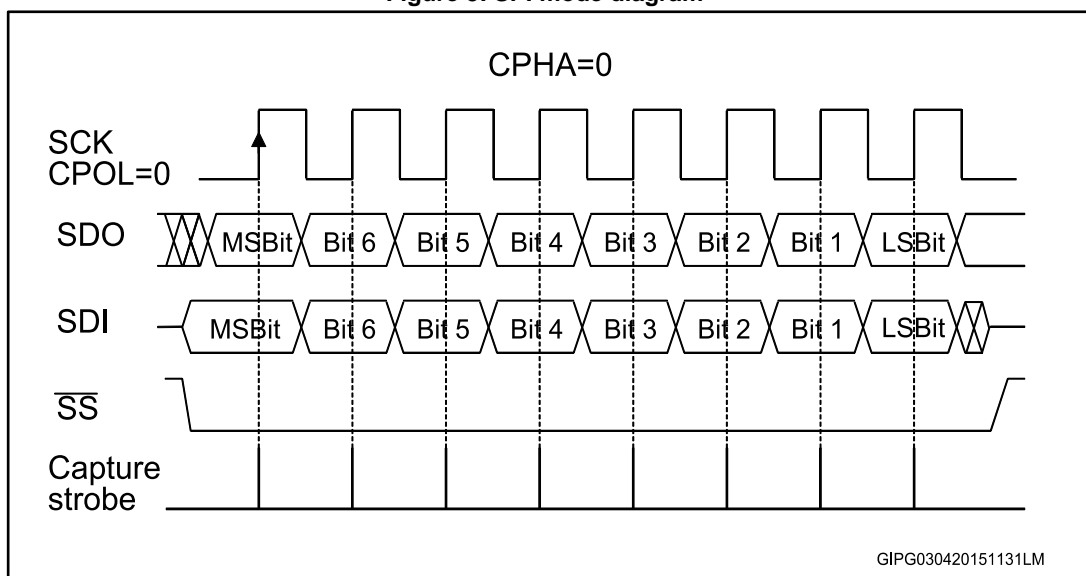
If SEL2 = H, the CLK line is the input clock for serial data sampling. On CLK rising edge the SDI input is sampled by the IC and the SDO output is sampled by the host microcontroller. On CLK falling edge, both SDI and SDO lines are updated to the next bit of the frame, from the most to the less significant one.

When the  $\overline{SS}$  signal is high, slave not selected, the microcontroller should drive the CLK low (the settings for the MCU SPI port are CPHA = 0 and CPOL = 0).

## 8.5 Slave select ( $\overline{SS}$ )

If SEL2 = H, the slave select  $\overline{SS}$  signal is used to enable the VNI8200XP serial communication shift register; data is flushed-in through the SDI pin and flushed-out from the SDO pin only when the  $\overline{SS}$  pin is low. On the  $\overline{SS}$  pin falling edge the shift register (containing the fault conditions) is frozen, so any change on the power switches status is latched until the next  $\overline{SS}$  falling edge event and the SDO output is enabled. On the  $\overline{SS}$  pin rising edge event the 8/16 bits present on the SPI shift register are evaluated and the outputs are driven according to this frame. If more than 8/16 bits (depending on the SPI settings) are flushed inside only the last 8/16 are evaluated; the others are flushed out from the SDO pin after fault condition bits; in this way a proper communication is possible also in a daisy chain configuration.

Figure 5: SPI mode diagram



GIPG030420151131LM

## 8.6 8/16-bit selection (SEL1)

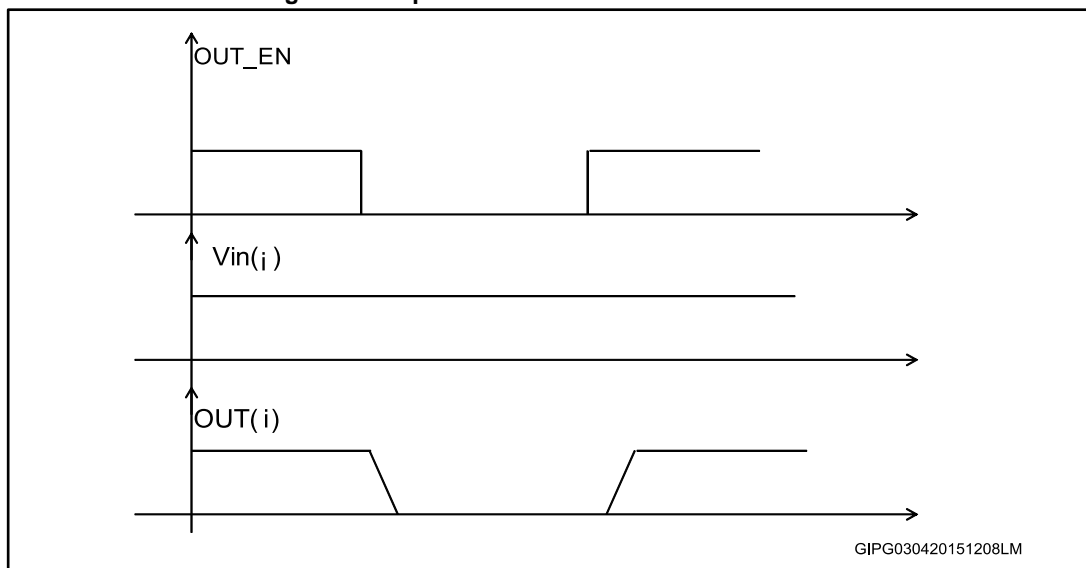
If SEL2 = H, SEL1 is used to select between two possible SPI configurations: the 8-bit SPI mode (SEL1 = L) and the 16-bit SPI mode (SEL1 = H). 8/16-bit SPI operation is described below.

## 8.7 Output enable (OUT\_EN)

If SEL2 = H, the OUT\_EN pin provides a fast way to disable all the outputs simultaneously. When the OUT\_EN pin is driven low for at least  $T_{RES}$ , the outputs are disabled while fault conditions in the SPI register are latched. To enable the outputs, the OUT\_EN pin should be raised and the IC should be re-programmed through the SPI interface. As fault conditions are latched inside the IC and SPI interface also works while the OUT\_EN pin is driven low, the SPI can be used to detect if a fault condition occurred before than the reset event.

The device is ready to operate normally after a  $T_{SU}$  period. The OUT\_EN pin is the fastest way to disable all outputs when a fault occurs.

Figure 6: Output channel enable/disable behavior



## 8.8 IC warning case temperature detection ( $\overline{\text{TWARN}}$ )

The  $\overline{\text{TWARN}}$  pin is an active low open drain output. This pin is activated if the IC case temperature exceeds  $T_{\text{CSD}}$ . According to the PCB thermal design and  $R_{\text{th(JC)}}$  value, this function allows a warning about a PCB overheating condition to be given.

$\overline{\text{TWARN}}$  bit is also available through SPI. This bit is not latched: the  $\overline{\text{TWARN}}$  pin is low only while the case overtemperature condition is active ( $T_{\text{C}} > T_{\text{CSD}}$ ) and is released when this condition is removed ( $T_{\text{C}} < T_{\text{CR}}$ ).

## 8.9 Fault indication ( $\overline{\text{FAULT}}$ )

The  $\overline{\text{FAULT}}$  pin is an open drain active low fault indication pin. This pin is activated by one or more of the following conditions:

- Channel overtemperature (OVT)

This pin is activated when at least one of the channels is in junction overtemperature.

Unlike the SPI fault detection bits, this signal is not latched: the  $\overline{\text{FAULT}}$  pin is low only when the fault condition is active and is released if the input driving signal is OFF or after the OVT protection condition has been removed. This last event occurs if the channel temperature decreases below the threshold level and the case temperature has not exceeded  $T_{\text{CSD}}$  or is below  $T_{\text{CR}}$ . This means that the  $\overline{\text{FAULT}}$  pin is low only while the junction overtemperature is active ( $T_{\text{J}} > T_{\text{TTSD}}$ ) and is released after this condition has been removed ( $T_{\text{J}} < T_{\text{R}}$  and  $T_{\text{C}} < T_{\text{CR}}$ ).

- Parity check fail

When SPI mode is used ( $\text{SEL2} = \text{H}$ ), if a parity check fault of the incoming SPI frame is detected or counted, CLK rising edges are different by a multiple of 8, the  $\overline{\text{FAULT}}$  pin is

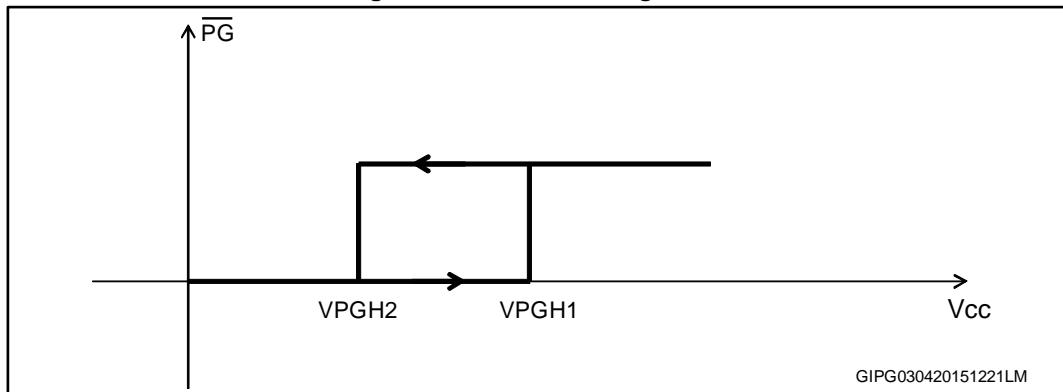
kept low. When counted CLK rising edges are a multiple of 8 and parity check is valid, the  $\overline{\text{FAULT}}$  pin is kept high.

### 8.10 Power Good ( $\overline{\text{PG}}$ )

The  $\overline{\text{PG}}$  terminal is an open drain, which indicates the status of the supply voltage. When  $V_{\text{CC}}$  supply voltage reaches the  $V_{\text{sth1}}$  threshold,  $\overline{\text{PG}}$  goes into a high impedance state. It goes into a low impedance state when  $V_{\text{CC}}$  falls below the  $V_{\text{sth2}}$  threshold.

In 16-bit SPI mode, a  $\overline{\text{PG}}$  bit is also available. This bit is set high when the Power Good diagnostic is active, it is otherwise cleared.

Figure 7: Power Good diagnostic



### 8.11 Programmable watchdog counter reset (WD)

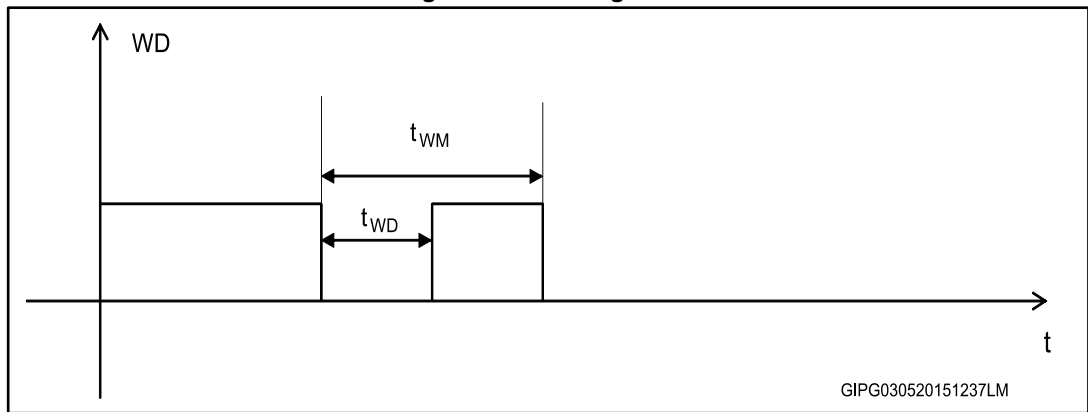
If  $\text{SEL2} = \text{H}$ , the VNI8200XP embeds a watchdog counter that must be erased, with a negative pulse on the WD pin, before it expires. If the WD counter elapses, the VNI8200XP goes into an internal reset state where all the outputs are disabled; to restart normal operation a negative pulse must be applied to the WD pin.

The watchdog enable/disable pin should be connected through an external divider to  $V_{\text{REG}}$ . The watchdog time is fixed in the following table:

Table 14: Programmable watchdog time

$V_{\text{WD\_EN}}$	$t_{\text{WM}}$
$0.25 V_{\text{REG}} > V_{\text{WD\_EN}}$	Disable
$0.25 V_{\text{REG}} \leq V_{\text{WD\_EN}} < 0.5 V_{\text{REG}}$	$40 \pm 12\% \text{ ms}$
$0.25 V_{\text{REG}} \leq V_{\text{WD\_EN}} < 0.75 V_{\text{REG}}$	$80 \pm 12\% \text{ ms}$
$0.75 V_{\text{REG}} \leq V_{\text{WD\_EN}} = V_{\text{REG}}$	$160 \pm 12\% \text{ ms}$

Figure 8: Watchdog reset



## 9 SPI operation (SEL2 = H)

### 9.1 8-bit SPI mode (SEL1 = L)

If SEL2 = H, the 8-bit SPI mode is based on an 8-bit command frame sent from the microcontroller to the IC; each bit directly drives the corresponding output where LSB drives output 0 and MSB drives output 7. Each bit, set to '1', activates (closes) the corresponding output.

At the same time, the IC transfers the channel fault conditions (OVT) to the microcontroller. These fault conditions are latched at the occurrence and cleared after each communication (each time the  $\overline{SS}$  signal has a positive transition). Each bit, set to '1', indicates an OVT condition for the corresponding channel.

**Table 15: Command 8-bit frame (master-to-slave)**

MSB								LSB
IN7	IN6	IN5	IN4	IN3	IN2	IN1	IN0	

**Table 16: Fault 8-bit frame (slave-to-master)**

MSB								LSB
F7	F6	F5	F4	F3	F2	F1	F0	

### 9.2 16-bit SPI mode (SEL1 = H)

The 16-bit SPI mode is based on a 16-bit command frame sent from the microcontroller to the IC; the first 8 bits directly drive the output channels (each bit, set to '1', activates the corresponding output), the other 8 bits contain a 4-bit parity check code where the last bit (the inversion of the previous one) is used to detect a communication error condition (providing at least a transition in each frame):

$$P0 = IN0 + IN1 + IN2 + IN3 + IN4 + IN5 + IN6 + IN7$$

$$P1 = IN1 + IN3 + IN5 + IN7$$

$$P2 = IN0 + IN2 + IN4 + IN6$$

$$nP0 = \text{Not } P0$$

**Table 17: Command 16-bit frame (master-to-slave)**

MSB																LSB
IN7	IN6	IN5	IN4	IN3	IN2	IN1	IN0					P2	P1	P0	nP0	

At the same time, the IC transfers to the microcontroller a 16-bit fault frame where the first 8 bits indicate a channel fault (OVT) condition (each bit, set to '1', indicates an OVT event), the following 4 bits provide general fault condition information. FB\_OK: this bit is related to the DC-DC regulation: at the DC-DC turn-on, this bit is low and becomes high after FB rises above 90% of the nominal  $V_{FB}$  voltage and a correct SPI communication occurred. If the FB voltage falls below 80% of the nominal  $V_{FB}$  voltage, this bit is zero;  $\overline{TWARN}$  (IC warning case temperature), PC (parity check fail, the bit, set to '1', indicates a PC fail or the



length is not a multiple of 8) and  $\overline{PG}$  . The last 4 bits are used as parity check bits and communication error condition (see command 16-bit frame):

$$P0 = F0 + F1 + F2 + F3 + F4 + F5 + F6 + F7$$

$$P1 = PC + \overline{FB\_OK} + F1 + F3 + F5 + F7$$

$$P2 = \overline{PG} + \overline{TWARN} + F0 + F2 + F4 + F6$$

$$nP0 = \text{not } P0$$

**Table 18: Fault 16-bit frame (slave-to-master)**

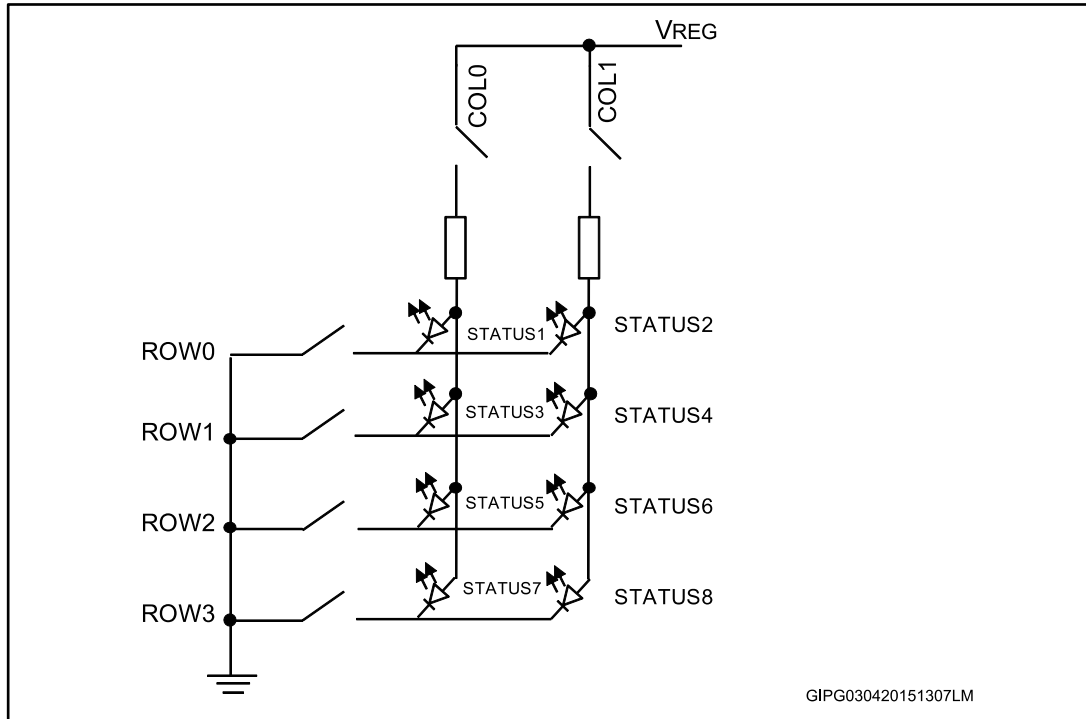
MSB														LSB	
F7	F6	F5	F4	F3	F2	F1	F0	FB_OK	$\overline{TWARN}$	PC	$\overline{PG}$	P2	P1	P0	nP0

Channel indications are latched and cleared after a communication only.

## 10 LED driving array

The LED driving array carries out the status of the output channels (ON or OFF).

Figure 9: LED driving array



The following equation is an indication how to choose the  $R_{ext}$  resistor value:

$$R_{ext} = (V_{COLmin.}) - (V_{ROWmax.}) - V_{F(LED)} / I_{F(LED)}$$

where  $I_{F(LED)} \leq 7 \text{ mA}$  and  $(V_{COL min.})$  and  $(V_{ROW max.})$  and  $V_{F(LED)}$  and  $I_{F(LED)}$  depend on the electrical characteristics of the LEDs.

## 11 Step-down switching regulator

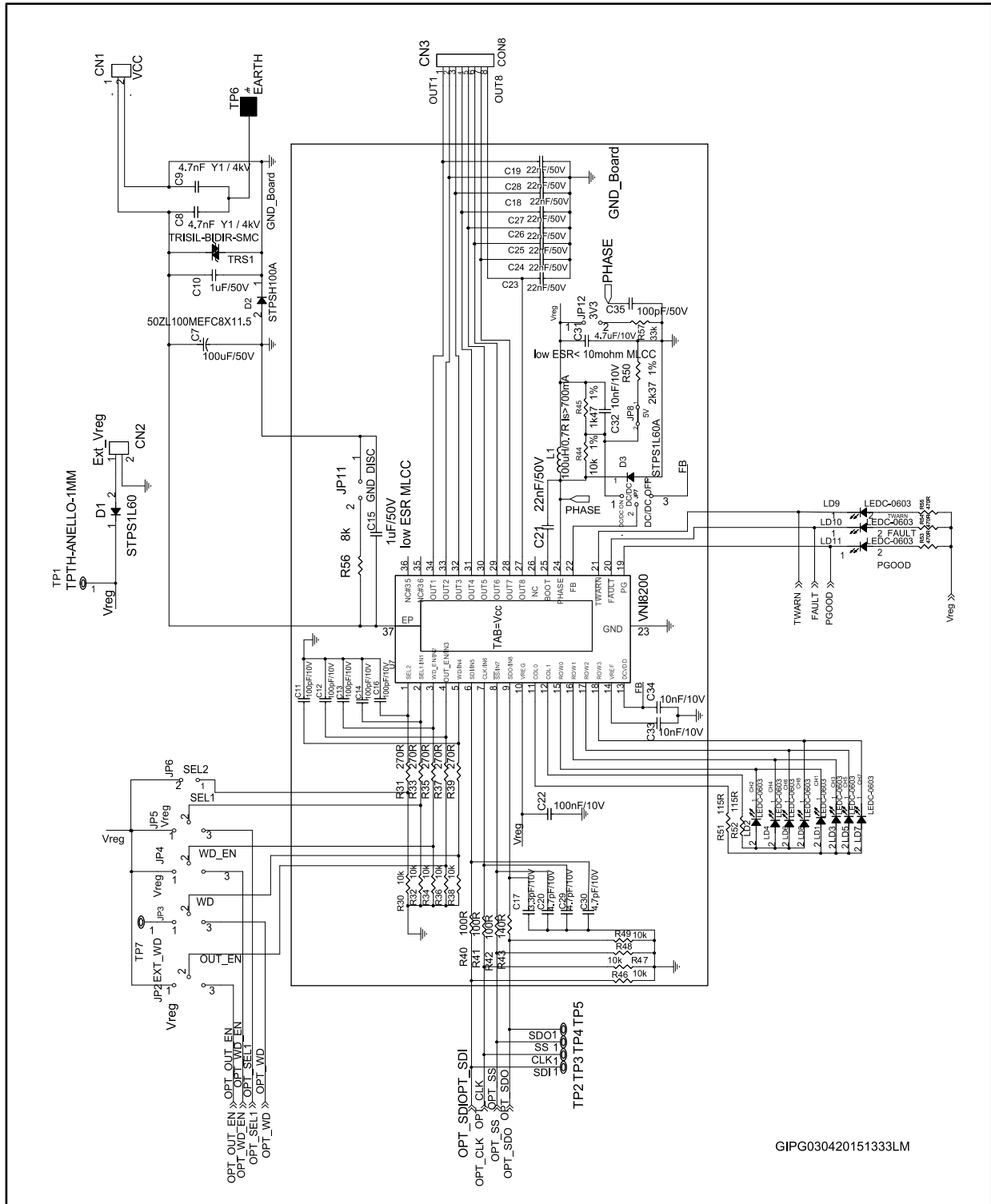
The IC embeds a high efficiency 100 mA micropower step-down switching regulator. The regulator is protected against short-circuit or overload conditions. Pulse-by-pulse current limit regulation is obtained in normal operation through a current loop control.

A low ESR output capacitor, connected to the  $V_{REG}$  helps to limit the regulated voltage ripple; a low ESR (less than 10 m $\Omega$ ) capacitor is preferable. The control loop pin FB allows 3.3 V to be regulated, connecting it directly to  $V_{REG}$ , or 5 V connecting it through a voltage divider  $R_1/R_{fb}$ . The DC-DC converter can be turned off by connecting the feedback pin to the DCVDD pin. In some applications it is possible to supply a 5 V or 3.3 V voltage externally or, in the case of two or more VNI8200XP devices inside the same board, it's possible to configure the DC-DC converter on only one device and also supply the other ICs.

if the DC-DC converter is adjusted to provide 3.3 V regulation and the  $V_{DC\_out}$  is used to power an external load and not the device, a 33 k $\Omega$  resistor has to be connected on  $V_{DC\_out}$  pin.

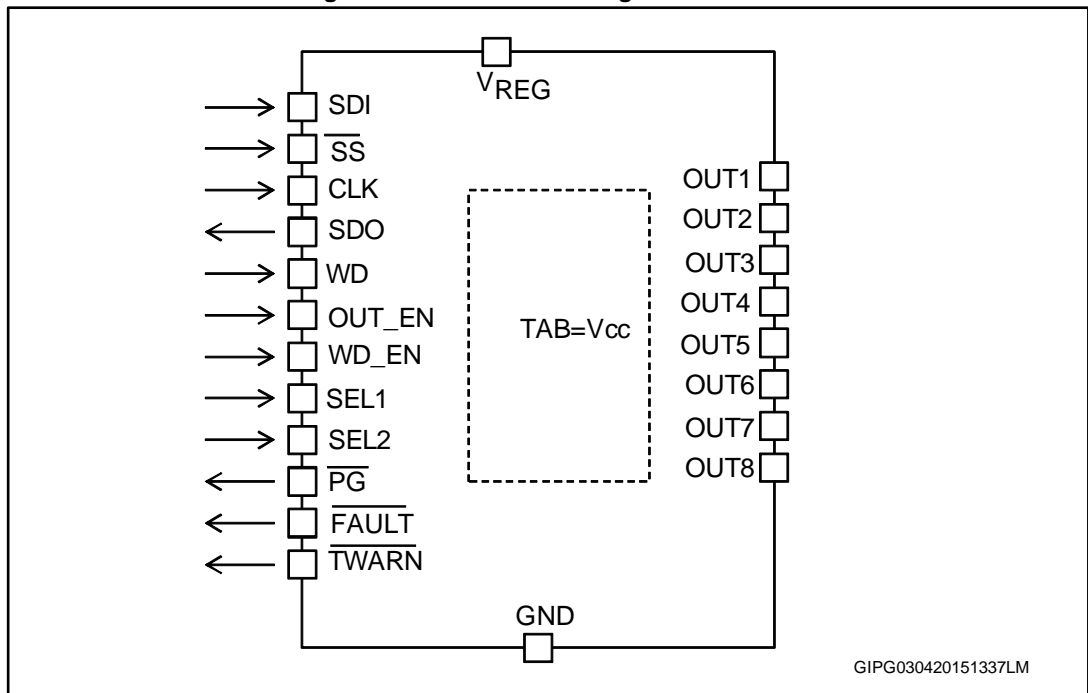


Figure 11: Typical circuit for switching regulation  $V_{DC-out} = 5 V$



GIPG030420151333LM

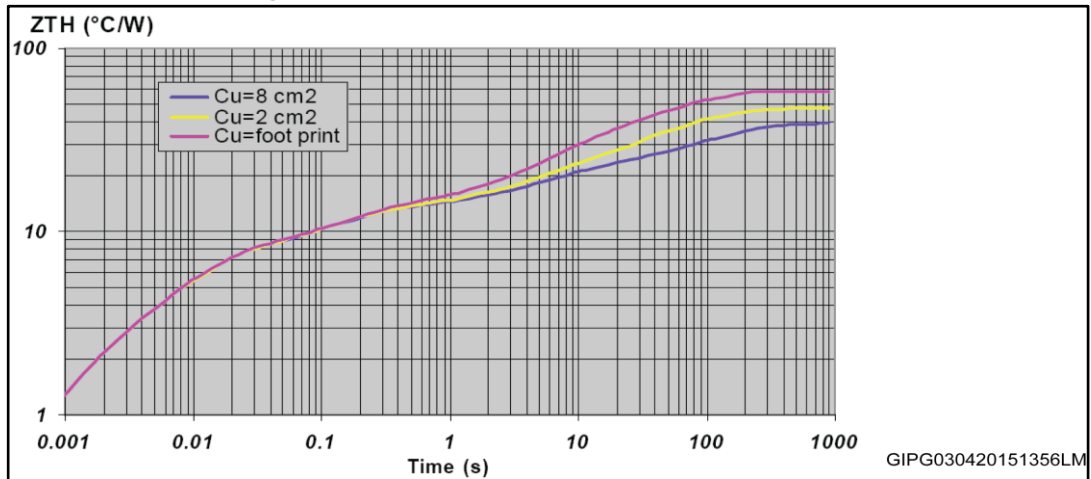
Figure 12: SPI directional logic convention



## 13 Thermal management

The power dissipation in the IC is the main factor that sets the safe operating condition of the device in the application. Therefore, it must be taken into account very carefully. Heatsinking can be achieved using copper on the PCB with proper area and thickness. The following image shows the junction-to-ambient thermal impedance values for the PowerSSO-36 package.

Figure 13: PowerSSO-36 thermal impedance vs. time



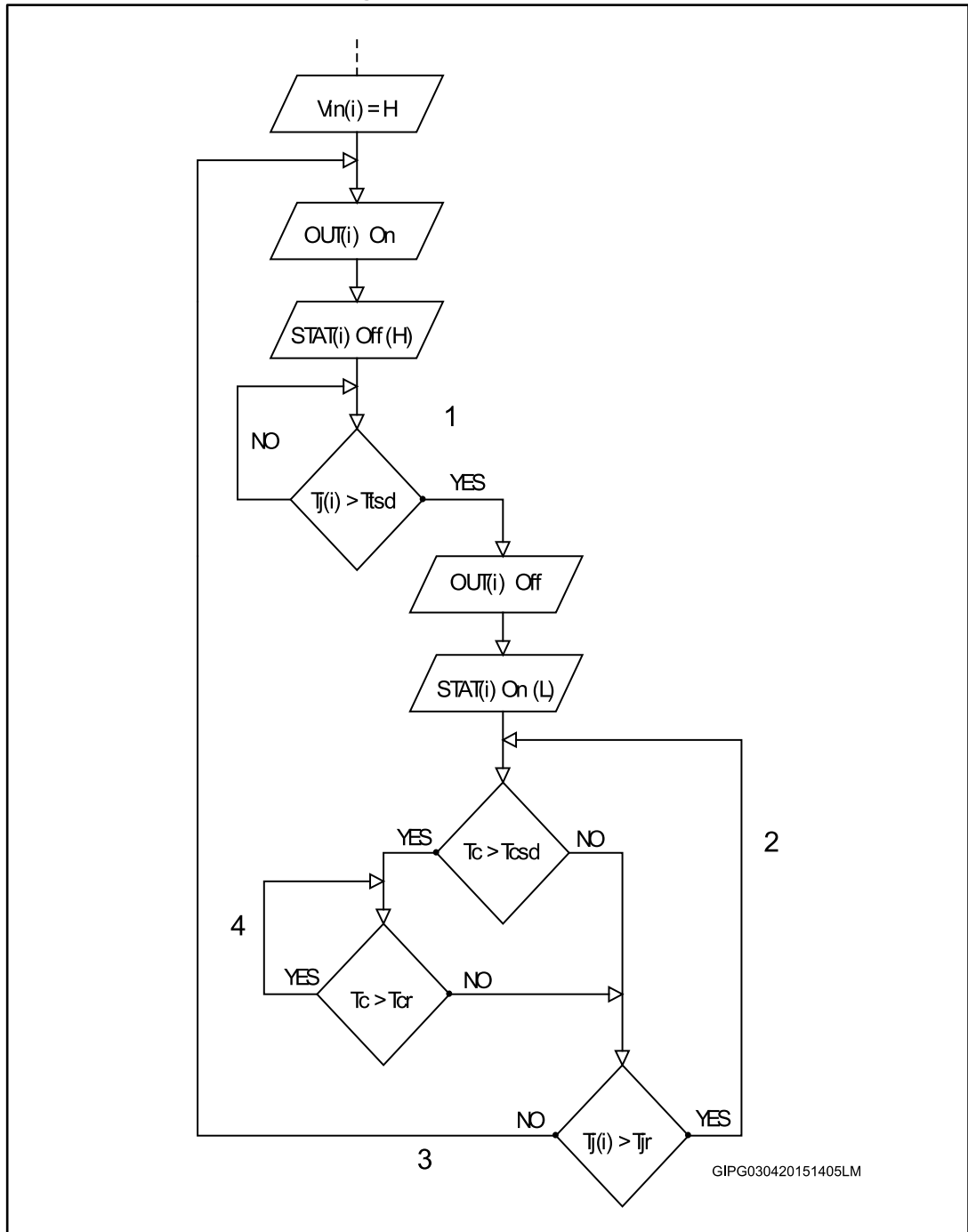
For instance, three cases have been considered using a PowerSSO-36 packaged with copper slug soldered on a 1.6 mm thickness FR4 board with dissipating footprint (copper thickness of 70  $\mu\text{m}$ ):





- single layer PCB with just IC footprint dissipating area
- double layer PCB with footprint dissipating area on the top side and a 2  $\text{cm}^2$  dissipating layer on the bottom side through 15 via holes

double layer PCB with footprint dissipating area on the top side and an 8  $\text{cm}^2$  dissipating layer on the bottom side through 15 via holes.

### 13.1 Thermal behavior

Figure 14: Thermal behavior

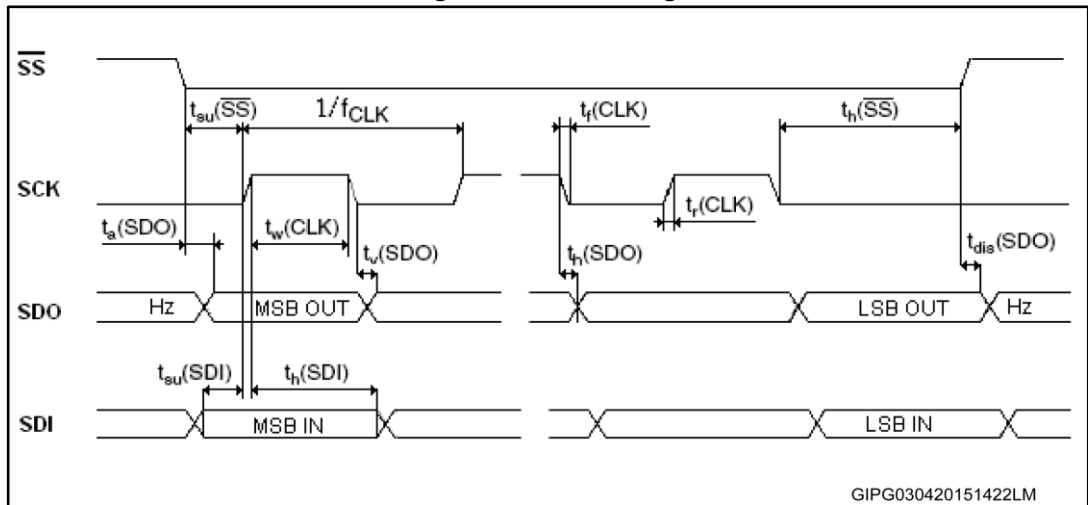


-  1 Thermal shutdown
-  2 Junction hysteresis
-  3 Restore to idle condition
-  4 Case hysteresis



# 14 Interface timing diagram

Figure 15: Serial timing



# 15 Switching parameter test conditions

Figure 16:  $dV/dt(ON)$  and  $dV/dt(OFF)$  time diagram test conditions

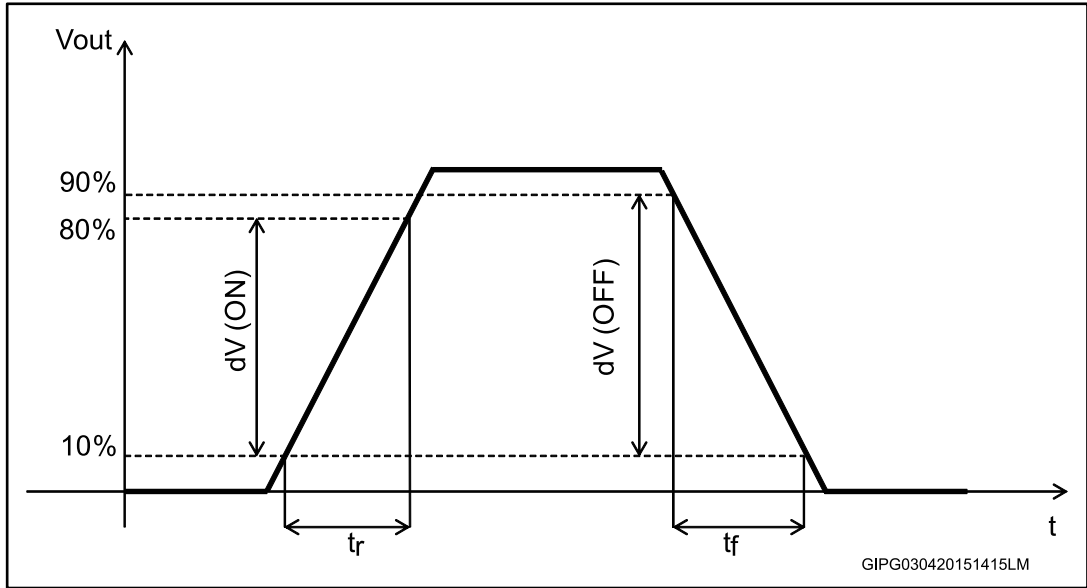
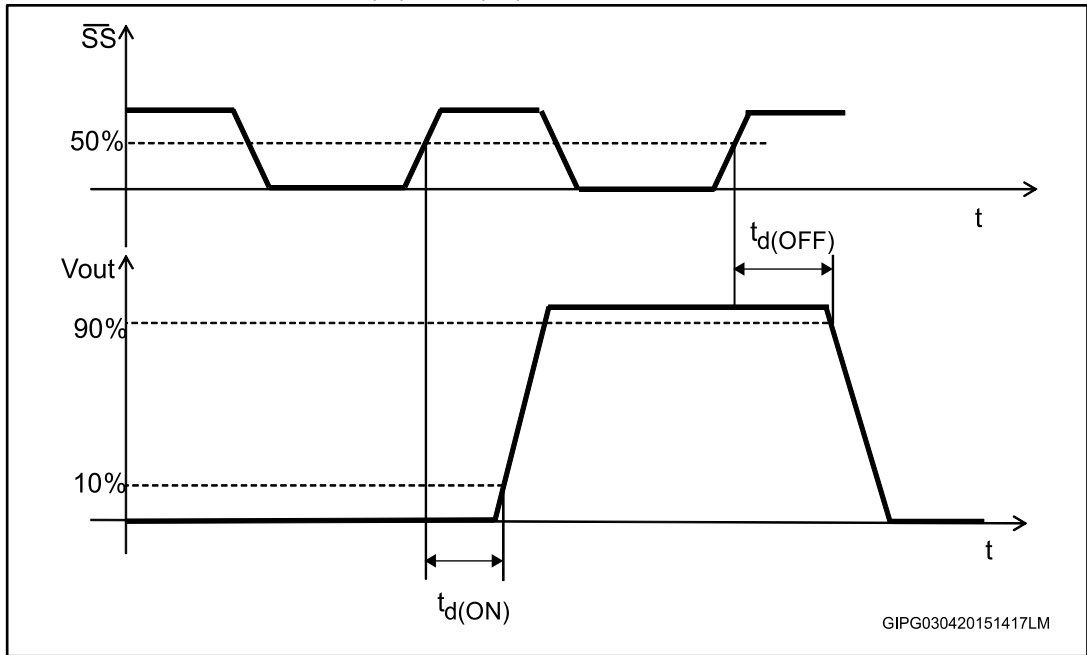


Figure 17:  $t_{d(ON)}$  and  $t_{d(OFF)}$  time diagram test conditions



## 16 Package information

In order to meet environmental requirements, ST offers these devices in different grades of ECOPACK<sup>®</sup> packages, depending on their level of environmental compliance. ECOPACK<sup>®</sup> specifications, grade definitions and product status are available at: [www.st.com](http://www.st.com). ECOPACK<sup>®</sup> is an ST trademark.

### 16.1 PowerSSO-36 package information

Figure 18: PowerSSO-36 package outline

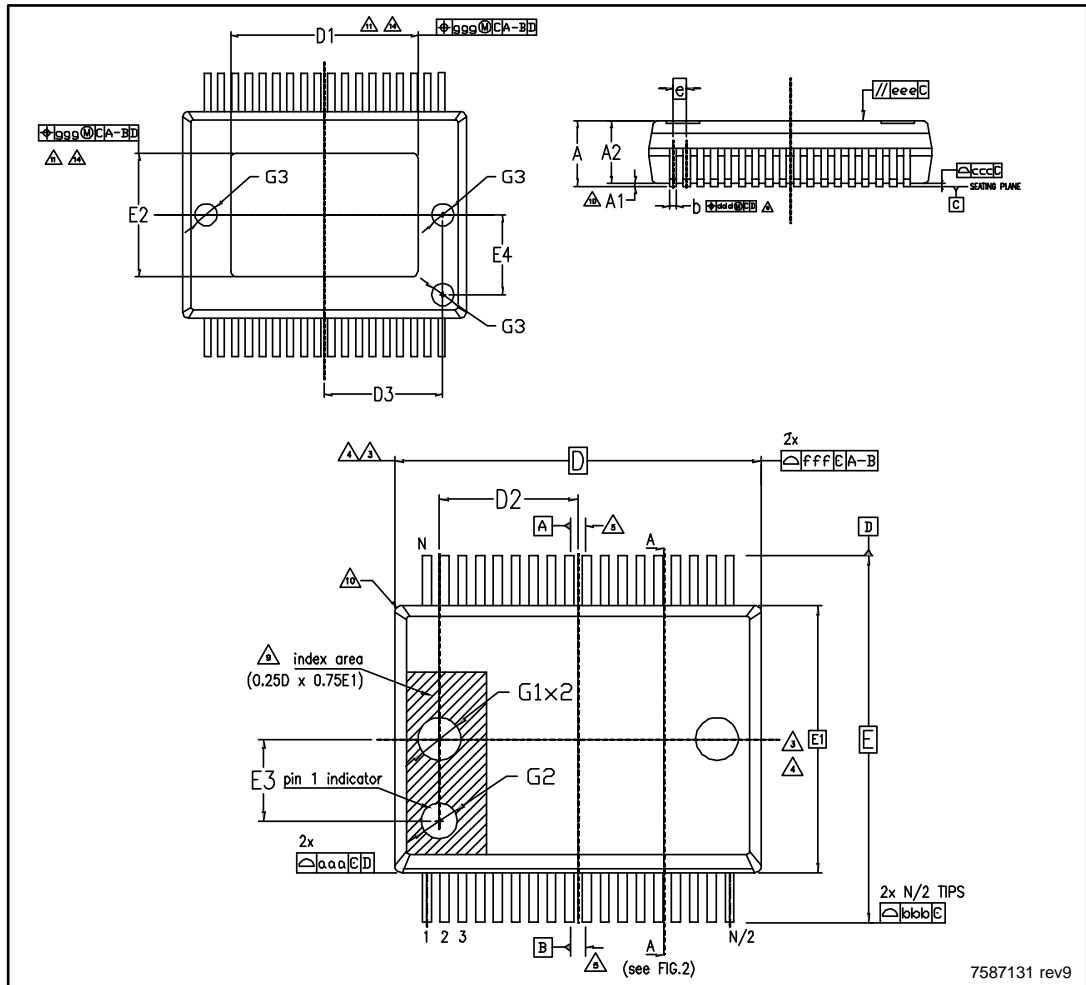


Figure 19: PowerSSO-36 package outline details

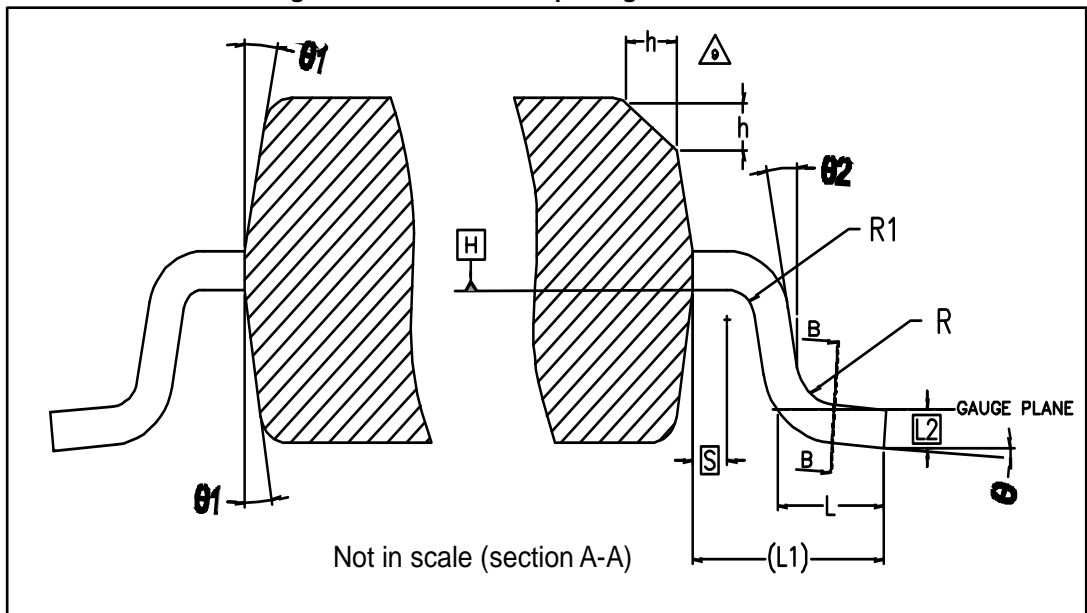


Figure 20: PowerSSO-36 package outline details (section B-B)

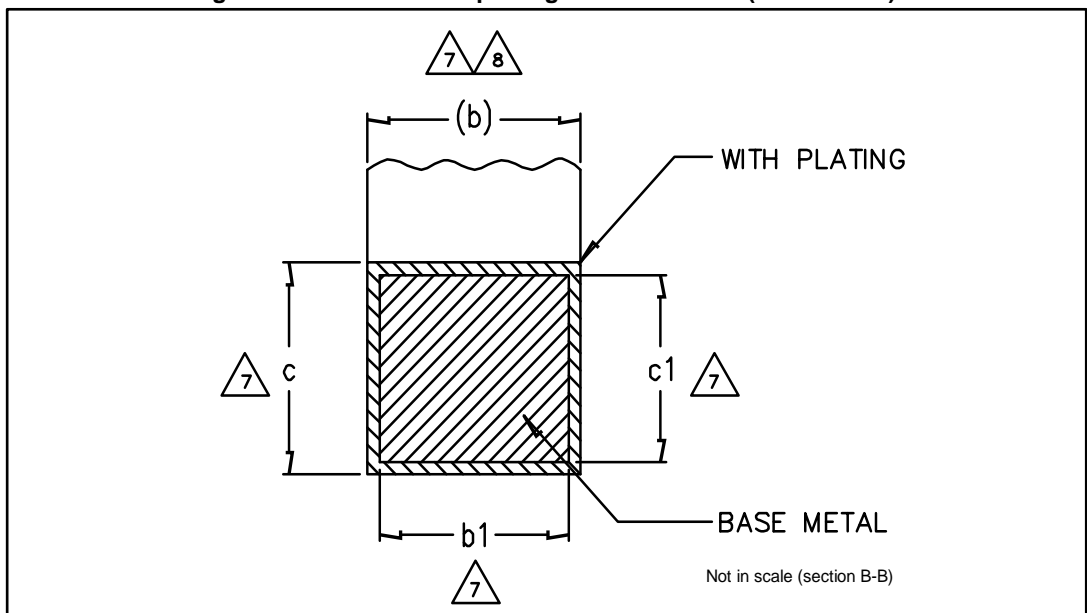


Table 19: PowerSSO-36 package mechanical data

Dim.	mm		
	Min.	Typ.	Max.
e	0°		8°
e1	5°		10°
e2	0°		
A	2.15		2.45
A1	0.00		0.10
A2	2.15		2.35
b	0.18		0.32
b1	0.13	0.25	0.30
c	0.23		0.32
c1	0.20	0.20	0.30
D	10.30 BSC		
D1	7.00		7.40
D2		3.65	4.200
D3		4.30	
e		0.50 BSC	
E		10.30 BSC	
E1		7.50 BSC	
E2	4.20		4.60
E3		2.30	
E4		2.90	
G1		1.20	
G2		1.00	
G3		0.80	
h	0.30		0.40
L	0.60	0.70	0.85
L1		1.40 REF	
L2		0.25 BSC	
N		36	
R	0.30		
R1	0.20		
S	0.25		

## 16.2 PowerSSO-36 packing information

Figure 21: PowerSSO-36 tube shipment outline

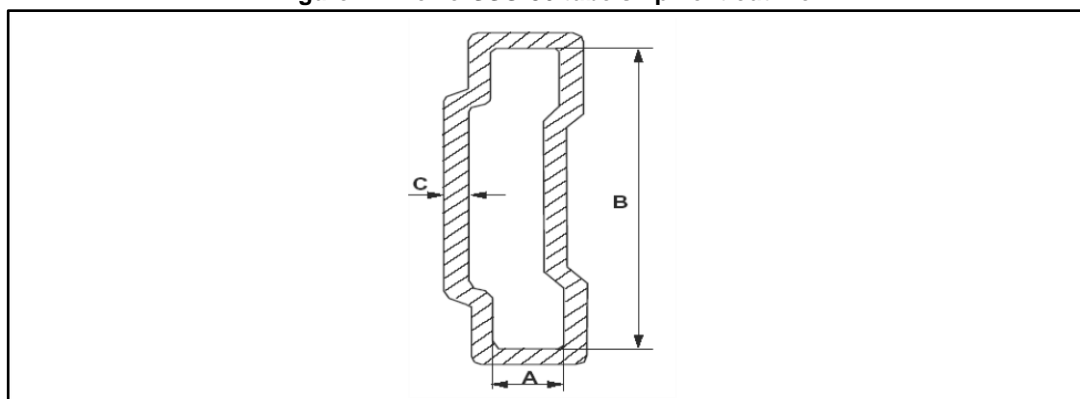


Table 20: PowerSSO-36 tube shipment mechanical data

Description	Value
Base quantity	49
Bulk quantity	1225
Tube length ( $\pm 0.5$ )	532
A	3.5
B	13.8
C ( $\pm 0.1$ )	0.6



All dimensions are in mm

Figure 22: PowerSSO-36 tape dimension outline

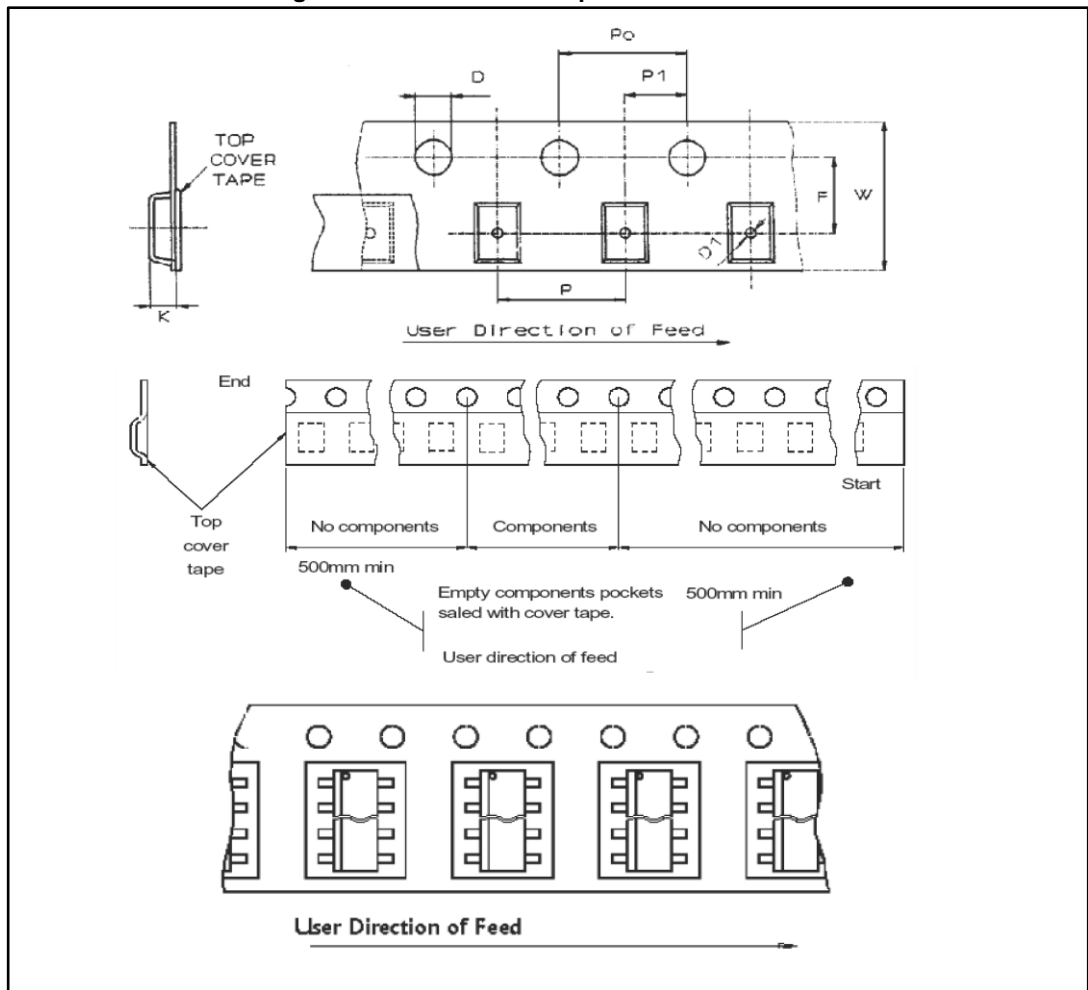


Table 21: PowerSSO-36 tape dimension mechanical data

Description	Dimension	Value
Tape width	W	24
Tape hole spacing	P0 (± 0.1)	4
Component spacing	P	12
Hole diameter	D (± 0.05)	1.55
Hole diameter	D1 (min.)	1.5
Hole position	F (± 0.1)	11.5
Compartment depth	K (max.)	2.85
Hole spacing	P1 (± 0.1)	2



According to the Electronic Industries Association (EIA) standard 481 rev. A, Feb 1986

Figure 23: PowerSSO-36 reel shipment outline

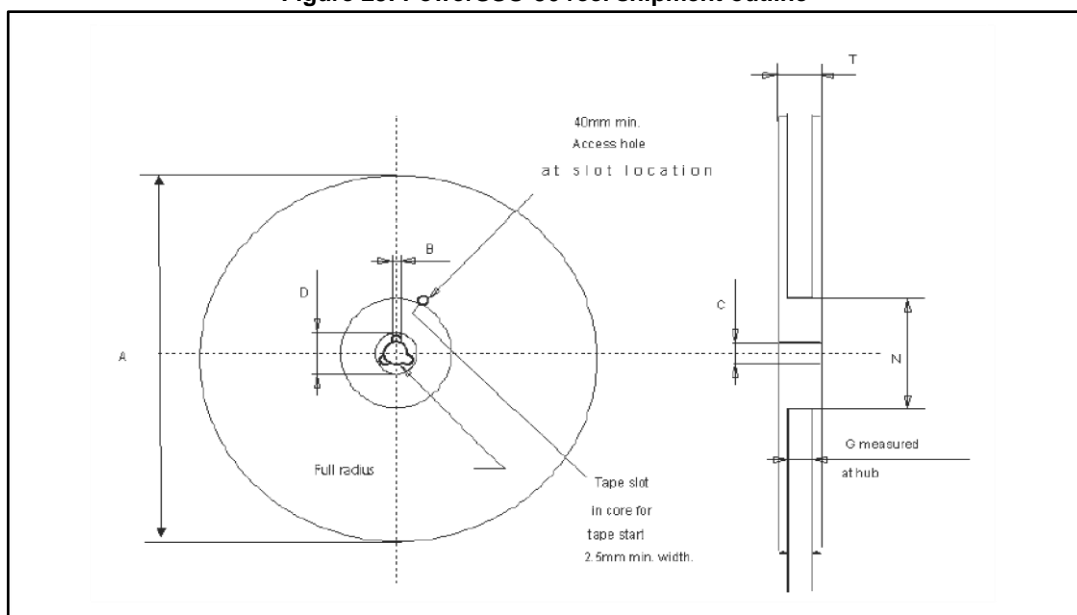


Table 22: PowerSSO-36 reel dimension mechanical data

Description	Value
Base quantity	1000
Bulk quantity	1000
A max.	330
B min.	1.5
C ( $\pm 0.2$ )	13
F	20.2
G ( $2 \pm 0$ )	24.4
N min.	100
T min.	30.4



## 17 Revision history

**Table 23: Document revision history**

Date	Revision	Changes
04-Dec-2008	1	Initial release.
29-Apr-2009	2	Updated table 5.
19-Jun-2012	3	Updated: Features, Section 9.4, Section 9.7, Section 9.9, Section 9.10, Section 12, Table 2, Table 3, Table 5, Table 7, Table 8, Table 9, Table 10, Table 11, Table 14, Figure 1, Figure 2. Changed: Figure 6, Figure 7, Figure 8, Figure 17, Figure 17. Content reworked to improve the readability.
27-Jun-2012	4	Updated section 10.2.
08-Mar-2013	5	Updated Table 5, Table 9, Table 10, Table 14. Updated footnote 2. in Table 4. Updated Section 12. Added Section 6. Changed Figure 10 and Figure 11. Added Table 12. Changed product status to production data.
04-Dec-2013	6	Updated EAS parameter in Table 3: Absolute maximum ratings. Updated Section 6: Reverse polarity protection. Added Section 7: Demagnetization energy.
20-Feb-2014	7	Changed figure 4
04-May-2015	8	Updated package information section.

**IMPORTANT NOTICE – PLEASE READ CAREFULLY**

STMicroelectronics NV and its subsidiaries ("ST") reserve the right to make changes, corrections, enhancements, modifications, and improvements to ST products and/or to this document at any time without notice. Purchasers should obtain the latest relevant information on ST products before placing orders. ST products are sold pursuant to ST's terms and conditions of sale in place at the time of order acknowledgement.

Purchasers are solely responsible for the choice, selection, and use of ST products and ST assumes no liability for application assistance or the design of Purchasers' products.

No license, express or implied, to any intellectual property right is granted by ST herein.

Resale of ST products with provisions different from the information set forth herein shall void any warranty granted by ST for such product.

ST and the ST logo are trademarks of ST. All other product or service names are the property of their respective owners.

Information in this document supersedes and replaces information previously supplied in any prior versions of this document.

© 2015 STMicroelectronics – All rights reserved

# AMEYA360

## Components Supply Platform

### Authorized Distribution Brand :



### Website :

Welcome to visit [www.ameya360.com](http://www.ameya360.com)

### Contact Us :

#### ➤ Address :

401 Building No.5, JiuGe Business Center, Lane 2301, Yishan Rd  
Minhang District, Shanghai , China

#### ➤ Sales :

Direct +86 (21) 6401-6692

Email [amall@ameya360.com](mailto:amall@ameya360.com)

QQ 800077892

Skype [ameyasales1](#) [ameyasales2](#)

#### ➤ Customer Service :

Email [service@ameya360.com](mailto:service@ameya360.com)

#### ➤ Partnership :

Tel +86 (21) 64016692-8333

Email [mkt@ameya360.com](mailto:mkt@ameya360.com)