

## Step-up controller for LED supply

### Features

- Input voltage range from 0.8 V to 3.6 V
- Overvoltage protection
- Drives N-channel MOSFET or NPN bipolar transistor
- No control loop compensation required
- FET driver for very precise PWM dimming

### Applications

- Single/dual cell NiMH, NiCd, or alkaline batteries
- Small appliances LED lighting
- Portable lighting

### Description

The STLDC08 LED driver step-up controller is optimized to operate from one or two NiCd/NiMH or alkaline cells. The IC is able to drive an external MOSFET (N-channel) enabling it for use with wide power levels. Hysteretic control eliminates the need for small signal control loop compensation. The IC integrates an FET driver for a precise PWM dimming. STLDC08 comes in a DFN10 (3 x 3 mm) package.

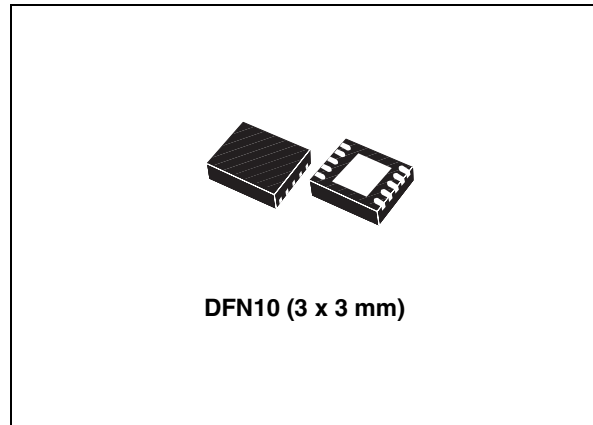

**Table 1. Device summary**

| Order code | Marking | Package           |
|------------|---------|-------------------|
| STLDC08PUR | STLDC08 | DFN10 (3 x 3 mm.) |

# Contents

|           |  |           |
|-----------|--|-----------|
| <b>1</b>  | <b>Application diagram</b> .....                 | <b>3</b>  |
| <b>2</b>  | <b>Absolute maximum ratings</b> .....            | <b>5</b>  |
| <b>3</b>  | <b>Pin configuration</b> .....                   | <b>6</b>  |
| <b>4</b>  | <b>Electrical characteristics</b> .....          | <b>7</b>  |
| <b>5</b>  | <b>Typical performance characteristics</b> ..... | <b>9</b>  |
| <b>6</b>  | <b>Block diagram</b> .....                       | <b>11</b> |
| <b>7</b>  | <b>Detailed description</b> .....                | <b>12</b> |
|           | 7.1 Main control loop .....                      | 12        |
|           | 7.2 Start up .....                               | 12        |
|           | 7.3 Over voltage protection (OVP) .....          | 13        |
|           | 7.4 Enable/PWM .....                             | 13        |
|           | 7.5 Dimming .....                                | 14        |
| <b>8</b>  | <b>Application information</b> .....             | <b>15</b> |
|           | 8.1 LED current programming .....                | 15        |
|           | 8.2 Duty cycle .....                             | 15        |
|           | 8.3 Inductor selection .....                     | 15        |
|           | 8.4 Inductor peak current limit .....            | 17        |
|           | 8.5 Power MOSFET selection .....                 | 18        |
|           | 8.6 Schottky diode selection .....               | 20        |
|           | 8.7 Input capacitor .....                        | 20        |
|           | 8.8 Output capacitor .....                       | 20        |
| <b>9</b>  | <b>Demonstration board</b> .....                 | <b>21</b> |
| <b>10</b> | <b>Layout suggestion</b> .....                   | <b>22</b> |
| <b>11</b> | <b>Package mechanical data</b> .....             | <b>24</b> |

**12**      **Revision history** ..... **28**

# 1 Application diagram

Figure 1. Electric schematic optimized for 2 LEDs and  $I_{LED} = 200\text{ mA}$

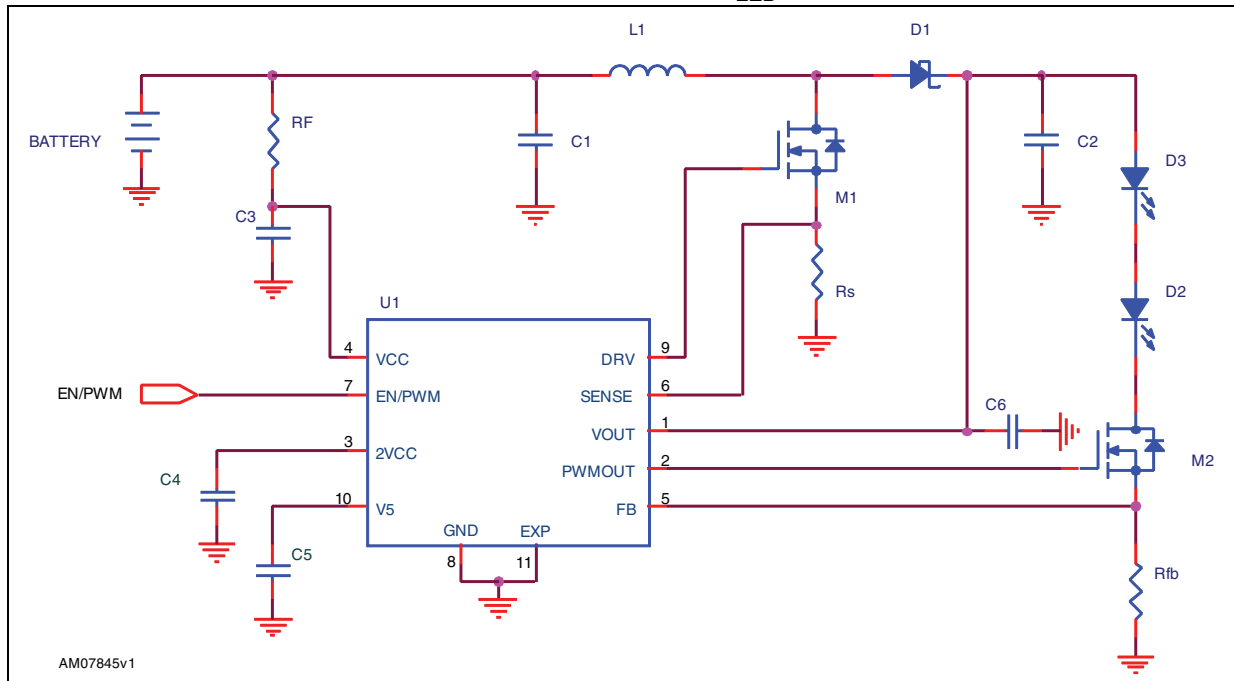

Table 2. List of components

| Reference  | Manufacturer       | Part number        | Value                     | Size        |
|------------|--------------------|--------------------|---------------------------|-------------|
| C1         | Murata             | GRM21BR60J475      | 4.7 $\mu\text{F}$ , 6.3 V | 0805        |
| C2         | Murata             | GRM31CB31C106K     | 10 $\mu\text{F}$ , 16 V   | 1206        |
| C4         | Murata             | GRM188R70J103KA01B | 10 nF, 6.3 V              | 0603        |
| C3, C5, C6 | Murata             | GRM188R61C105K     | 1 $\mu\text{F}$ , 16 V    | 0603        |
| L          | Coilcraft          | LPS6235-103ML      | 10 $\mu\text{H}$          | 6 mm x 6 mm |
| M1,M2      | STMicroelectronics | STS5DNF20V         |                           | SO-8        |
| D1         | STMicroelectronics | STPS2L30           |                           | SMA         |
| Rfb        |                    |                    | 0.47 $\Omega$             | 0805        |
| Rs         |                    |                    | 0.047 $\Omega$            | 0805        |
| RF         |                    |                    | 0 $\Omega$                | 0603        |

Figure 2. Electric schematic optimized for 4 LEDs and  $I_{LED} = 300\text{ mA}$

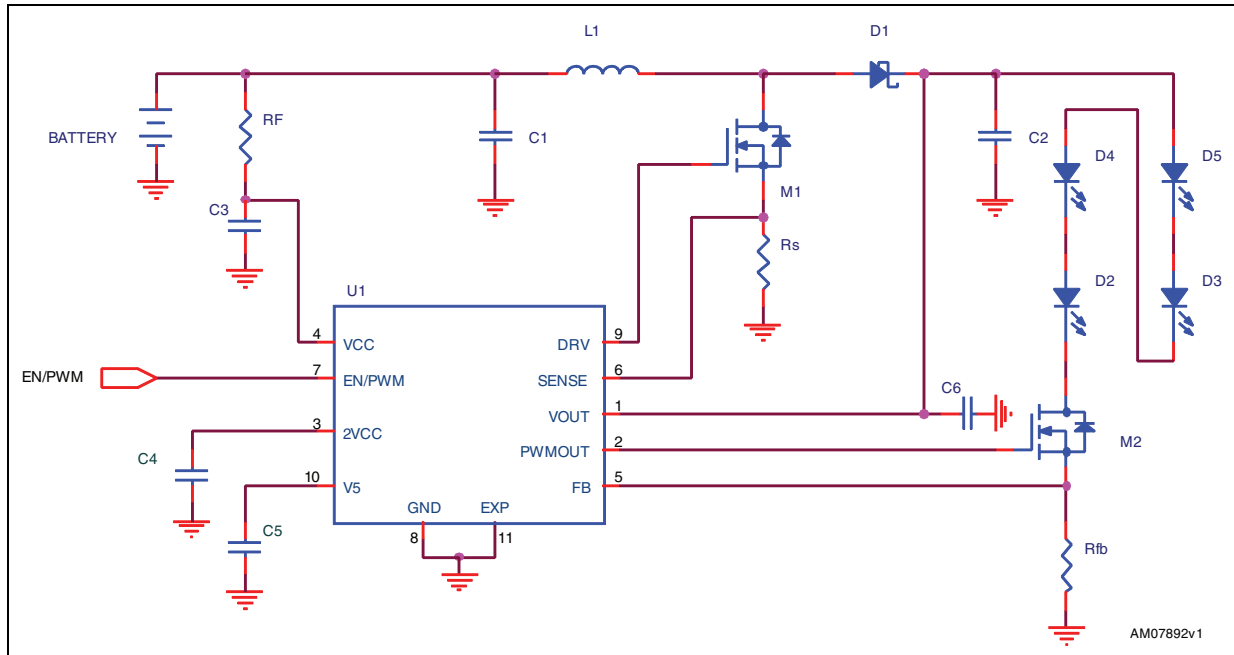

Table 3. List of components

| Part reference | Manufacturer       | Part number        | Value                    | Size              |
|----------------|--------------------|--------------------|--------------------------|-------------------|
| C1             | Murata             | GRM21BR60J106KE19  | 10 $\mu\text{F}$ , 6.3 V | 0805              |
| C2             | Murata             | GRM31CR61C226K     | 22 $\mu\text{F}$ , 16 V  | 1206              |
| C4             | Murata             | GRM188R70J103KA01B | 10 nF, 6.3 V             | 0603              |
| C3, C5, C6     | Murata             | GRM188R61C105K     | 1 $\mu\text{F}$ , 16 V   | 0603              |
| M1, M2         | STMicroelectronics | STS5DNF20V         |                          | SO-8              |
| D1             | STMicroelectronics | STPS2L30           |                          | SMA               |
| L              | Coilcraft          | DO3316P-223_L      | 22 $\mu\text{H}$         | 12.95 mm x 9.4 mm |
| Rfb            |                    |                    | 0.33 $\Omega$            | 0805              |
| Rs             |                    |                    | 0.033 $\Omega$           | 0805              |
| RF             |                    |                    | 0 $\Omega$               | 0603              |

## 2 Absolute maximum ratings

**Table 4. Absolute maximum ratings**

| Symbol      | Parameter                                   | Value               | Unit             |
|-------------|---|---------------------|------------------|
| $V_{CC}$    | Supply voltage                              | - 0.3 to 4.6        | V                |
| EN/PWM      | Analog input                                | - 0.3 to 7          | V                |
| FB          | Analog input                                | - 0.3 to 2          | V                |
| SENSE       | Analog input                                | - 0.3 to 20         | V                |
| $2V_{CC}$   | Analog outputs                              | 0 to 4              | V                |
| V5          | Analog outputs                              | - 0.3 to 7          | V                |
| DRV, PWMOUT | Analog outputs                              | $V_{CC} - 1.2$ to 7 | V                |
| $V_{OUT}$   | Output voltage                              | - 0.3 to 20         | V                |
| ESD         | Human body model (all pins)                 | $\pm 2$             | kV               |
| $P_D$       | DFN10L 3x3 $T_A = 25\text{ }^\circ\text{C}$ | 2.2                 | W                |
| $T_J$       | Junction temperature                        | - 40 to 85          | $^\circ\text{C}$ |
| $T_{STG}$   | Storage temperature range                   | - 55 to 85          | $^\circ\text{C}$ |

*Note: Absolute maximum ratings are those values beyond which damage to the device may occur. Functional operation under these conditions is not implied.*

**Table 5. Thermal data**

| Symbol     | Parameter                           | Value               | Unit                      |
|------------|-------------------------------------|---------------------|---------------------------|
| $R_{thJC}$ | Thermal resistance junction-case    | 3                   | $^\circ\text{C}/\text{W}$ |
| $R_{thJA}$ | Thermal resistance junction-ambient | 57.1 <sup>(1)</sup> | $^\circ\text{C}/\text{W}$ |

1. With two sides, two planes PCB following EIA/JEDEC JESD51-7 standard.

### 3 Pin configuration

Figure 3. Pin connections (top through view)

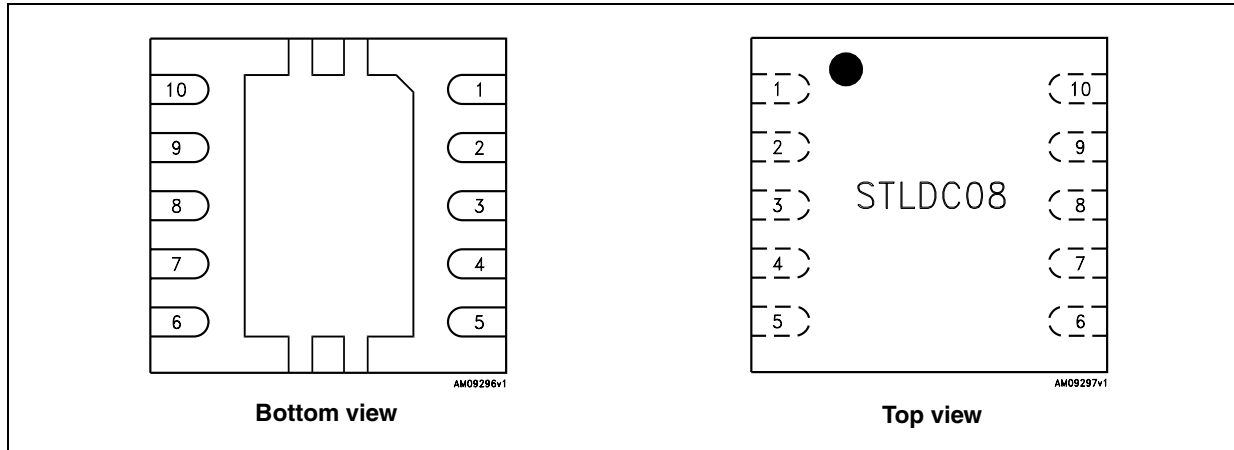

Table 6. Pin description

| Pin # | Pin name    | Pin function   |
|-------|-------------|--|
| 1     | VOUT        | Over voltage protection and supply pin for the IC when $V_{OUT} > 2\text{ V}$  |
| 2     | PWMOUT      | Driver of the external MOSFET for PWM dimming. The driver stage is controlled by EN/PWM signal                             |
| 3     | 2Vcc        | Charge pump output   |
| 4     | VCC         | Supply voltage when $V_{OUT} < 2\text{ V}$ , this pin represents the input of the internal charge pump                     |
| 5     | FB          | Feedback pin for LED current control   |
| 6     | SENSE       | Sense resistor for current mode control and peak current limit   |
| 7     | EN/PWM      | Enable pin and PWM control input for PWMOUT pin  |
| 8     | GND         | Ground reference   |
| 9     | DRV         | Driver output for Boost stage MOSFET   |
| 10    | V5          | Internal regulator output. Decouple this pin locally to the IC ground with a minimum of $1\ \mu\text{F}$ ceramic capacitor |
|       | Exposed Pad | The exposed pad needs to be connected and soldered to analog ground  |

## 4 Electrical characteristics

$T_A = -40$  to  $85$ ;  $C_{IN} = 22 \mu\text{F}$ ;  $C_{OUT} = 10 \mu\text{F}$ ;  $\text{PWMOUT} = 3300 \text{ pF}$ ;  $\text{DVR} = 3300 \text{ pF}$ ;  $2V_{CC} = 10 \text{ nF}$ ;  $V_5 = 1 \mu\text{F}$ ;  $V_{CC} = 1.5\text{V}$ ;  $V_{OUT} = 3 \text{ V}$ ;  $\text{FB} = \text{GND}$ ;  $\text{SENSE} = \text{GND}$ ;  $\text{EN/PWM} = V_{CC}$ ; unless otherwise specified.

**Table 7. Electrical characteristics**

| Symbol                             | Parameter   | Test conditions                                      | Min. | Typ. | Max. | Unit          |
|------------------------------------|---|--|------|------|------|---------------|
| <b>General section</b>             |   |  |      |      |      |               |
| $V_{CC}$                           | Supply voltage range  | $V_{OUT} = \text{GND}$                               | 0.8  |      | 3.6  | V             |
| $I_{VCC}$                          | Supply current measured on $V_{CC}$ pin with charge pump ON | $V_{OUT} = \text{GND}$                               |      | 3    |      | mA            |
|                                    | Shutdown current  | EN = GND Shutdown mode                               |      | 5    | 10   | $\mu\text{A}$ |
| OVP                                | Overvoltage protection                                      | Rising edge  | 18   |      | 19.5 | V             |
| $I_{VOUT}$                         | Operating supply current measured on $V_{OUT}$ pin          | $V_{OUT} = 3 \text{ V}$ , FB = 500 mV (no switching) |      | 60   | 100  | $\mu\text{A}$ |
|                                    |   | $V_{OUT} = 3 \text{ V}$ , FB = GND (switching)       |      | 800  |      | $\mu\text{A}$ |
|                                    |   | $V_{OUT} = 10 \text{ V}$ , FB = GND (switching)      |      | 1.3  | 2    | mA            |
|                                    | Shutdown current  | EN = GND   |      | 5    | 10   | $\mu\text{A}$ |
| 2VCC                               | Charge pump ON  | $V_{OUT}$ floating; $V_{CC} = 0.8 \text{ V}$         |      | 1.5  |      | V             |
| <b>Driver section (DRV output)</b> |   |  |      |      |      |               |
| $V_{DRVL}$                         | Low level voltage   | $I_{DRV} = 100 \text{ mA}$                           |      | 80   | 160  | mV            |
| $V_{DRVH}$                         | High level voltage  | $I_{DRV} = -100 \text{ mA}$                          |      | 120  | 240  | mV            |
| $t_R$                              | Rise time   | $C_{DRV} = 3300 \text{ pF}$                          |      | 30   |      | ns            |
| $t_F$                              | Fall time   | $C_{DRV} = 3300 \text{ pF}$                          |      | 20   |      | ns            |
| <b>FB</b>                          |   |  |      |      |      |               |
| $V_{FB}$                           | Feedback voltage  | $T_A = 25 \text{ }^\circ\text{C}$                    | 90   | 105  | 116  | mV            |
| $I_{FB}$                           | Bias current  | FB = 2 V   |      | 20   | 500  | nA            |
| <b>Timing</b>                      |   |  |      |      |      |               |
| $T_{OFF(MIN)}$                     | Minimum Off time  |  |      | 1    |      | $\mu\text{s}$ |
| $T_{ON(MAX)}$                      | Maximum On time   |  |      | 20   |      | $\mu\text{s}$ |
| <b>PWM OUT section</b>             |   |  |      |      |      |               |
| $V_{PWMOUTL}$                      | Low level voltage   | $I_{PWMOUT} = 100 \text{ mA}$                        |      | 200  | 400  | mV            |
| $V_{PWMOUTH}$                      | High level voltage  | $I_{PWMOUT} = -100 \text{ mA}$                       |      | 250  | 500  | mV            |
| $t_r$                              | Rise time   | $C_{PWMOUT} = 3300 \text{ pF}$                       |      | 30   |      | ns            |
| $t_f$                              | Fall time   | $C_{PWMOUT} = 3300 \text{ pF}$                       |      | 20   |      | ns            |

Table 7. Electrical characteristics (continued)

| Symbol                      | Parameter                       | Test conditions                        | Min. | Typ. | Max. | Unit    |
|-----------------------------|---------------------------------|--|------|------|------|---------|
| <b>SENSE</b>                |                                 |  |      |      |      |         |
| $V_{SENSE\ MAX}$            | Maximum current sense threshold |  | 70   | 100  | 130  | mV      |
| $I_{SENSE}$                 | Bias current                    | $V_{SENSE} = 20\ V$                    |      | 10   | 20   | $\mu A$ |
| <b>EN/PWM section</b>       |                                 |  |      |      |      |         |
| $V_{IL}$                    | Low level threshold             | $V_{CC} = 0.8\ V$                      |      |      | 0.3  | V       |
| $V_{IL}$                    | Low level threshold             | $V_{CC} = 3.6\ V$                      |      |      | 0.4  | V       |
| $V_{IH}$                    | High level threshold            | $V_{CC} = 0.8\ V$                      | 0.8  |      |      | V       |
| $V_{IH}$                    | High level threshold            | $V_{CC} = 3.6\ V$                      | 1.2  |      |      | V       |
| $I_{EN/PWM}$                | EN/PWM pin current              | EN/PWM = 3.6 V                         |      | 2    |      | $\mu A$ |
| $I_{EN/PWM}$                | EN/PWM pin current              | EN/PWM = 5 V                           |      | 5    |      | $\mu A$ |
| <b>+ 5 V regulator</b>      |                                 |  |      |      |      |         |
| V5                          | Output voltage                  | $V_{OUT} = 6\ V; I_5 = 10\ mA$         | 4.8  | 5    | 5.2  | V       |
| $\Delta V_5/\Delta V_{OUT}$ | Line regulation                 | $6\ V < V_{OUT} < 18\ V; I_5 = 10\ mA$ |      | 0.02 |      | %/V     |
| $\Delta V_5$                | Load regulation                 | $0 < I_5 < 10\ mA; V_{OUT} = 18\ V$    | 0.02 | 0.01 |      | %/mA    |
| $V_{DROPOUT}$               | Dropout voltage                 | $I_5 = 10\ mA$                         |      | 20   |      | mV      |
| $I_{CC}$                    | Short circuit current           | $V_{OUT} = 18\ V; V_5 = 0\ V$          |      | 140  |      | mA      |

## 5 Typical performance characteristics

Figure 4.  $V_{FB}$  vs. temperature

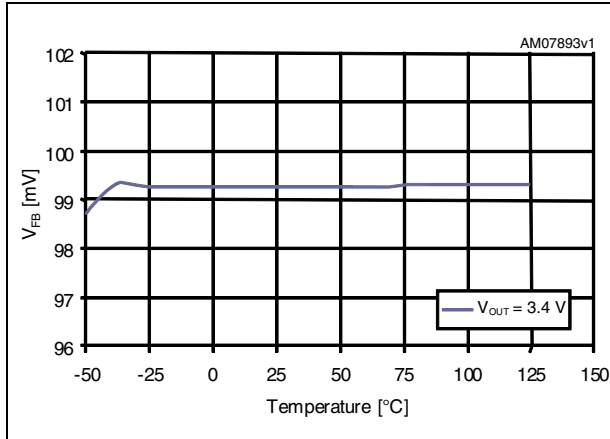

Figure 5. Maximum  $V_{SENSE}$  vs. temperature

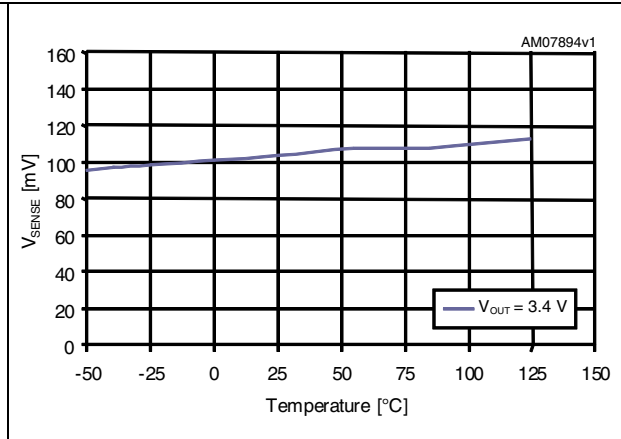

Figure 6.  $I_{OUT}$  vs. temperature FB = 0.5 V

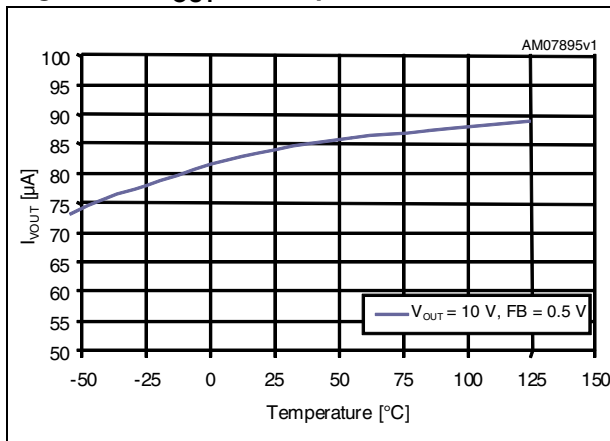

Figure 7.  $I_{OUT}$  vs. temperature FB = GND

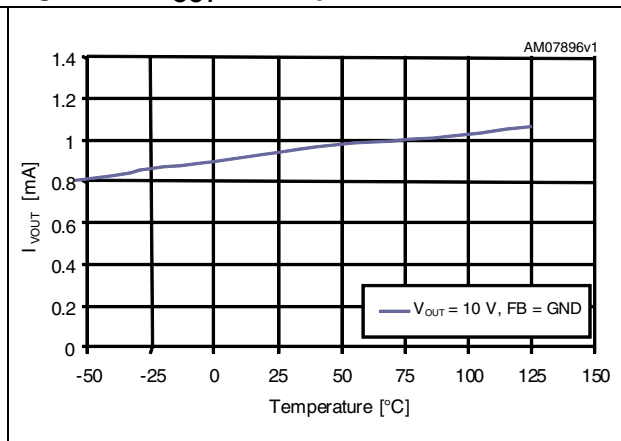

Figure 8. Efficiency vs. input voltage 2 LEDs

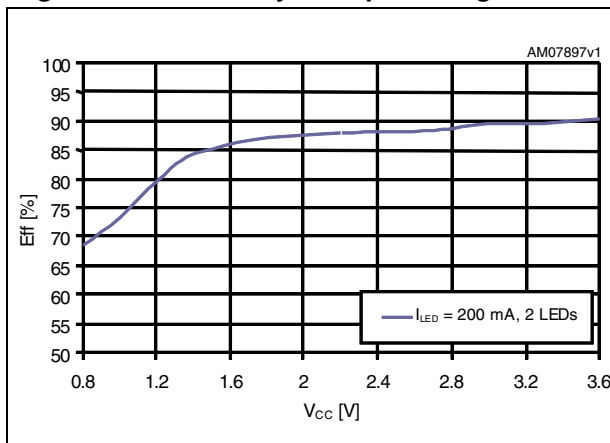

Figure 9. Efficiency vs. input voltage 4 LEDs

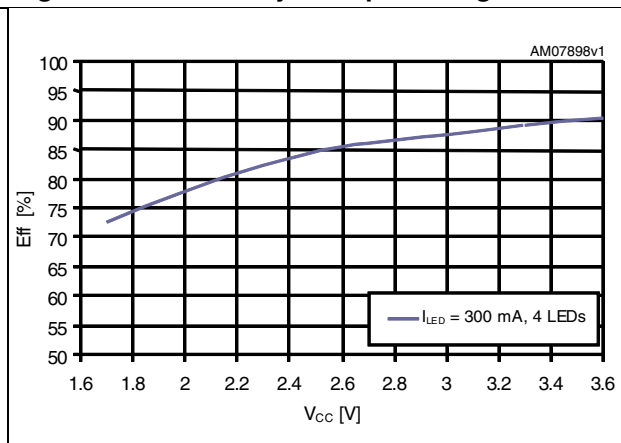

Figure 10. Startup timing and dimming  $I_{LED}$  vs. time, 2 LEDs

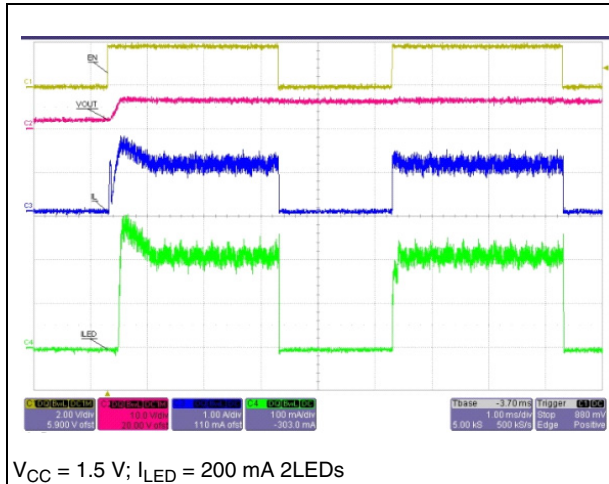

Figure 11. Dimming EN/PWM = 200 Hz, 2 LEDs

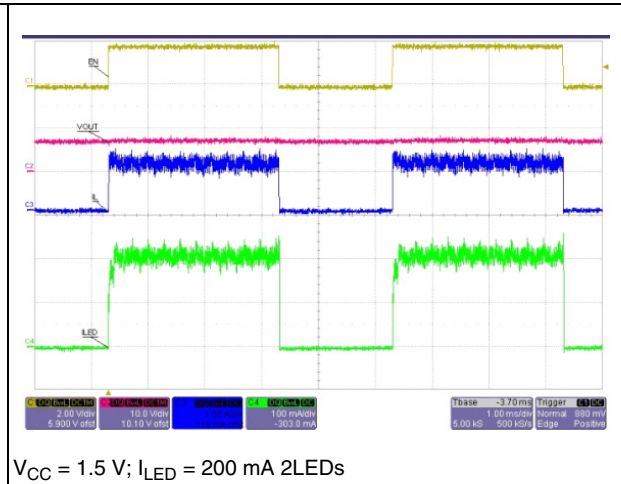

Figure 12. Startup timing and dimming  $I_{LED}$  vs. time, 4 LEDs

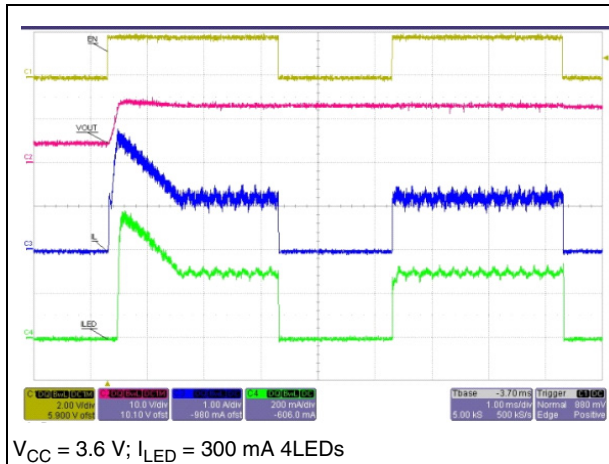

Figure 13. Dimming EN/PWM = 200 Hz, 4 LEDs

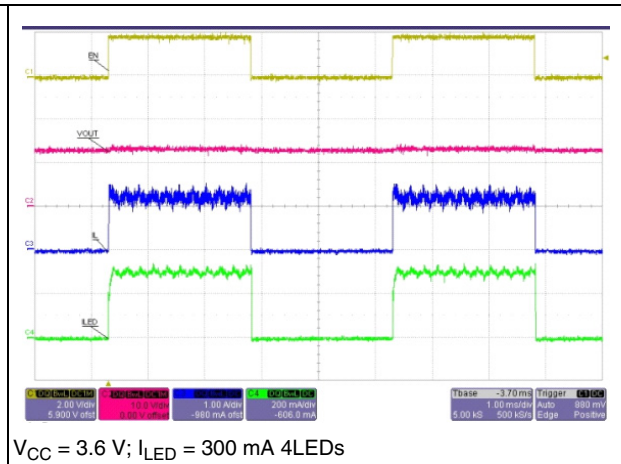

Figure 14.  $V_{CC} = 1.5\text{ V}$ ;  $I_{LED} = 200\text{ mA}$ , 2LEDs

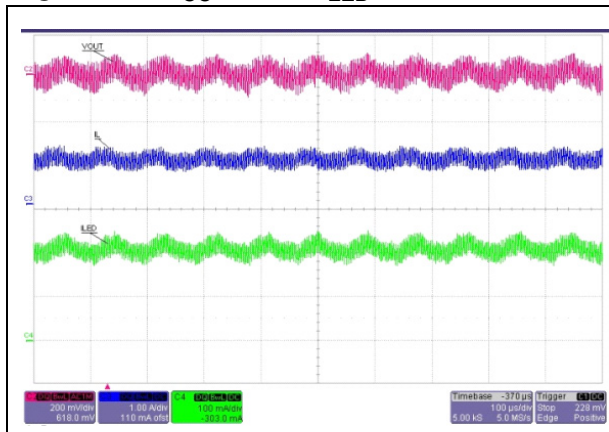
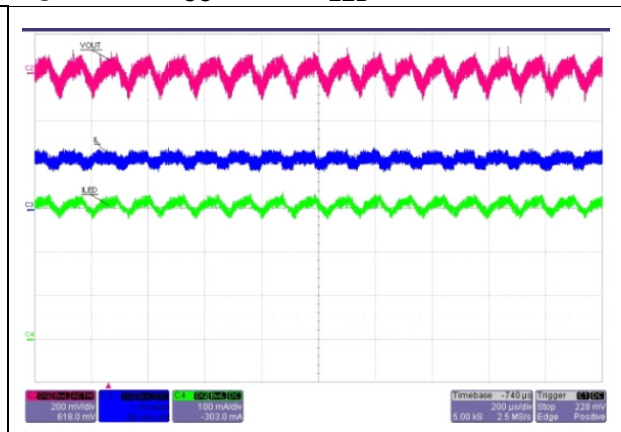
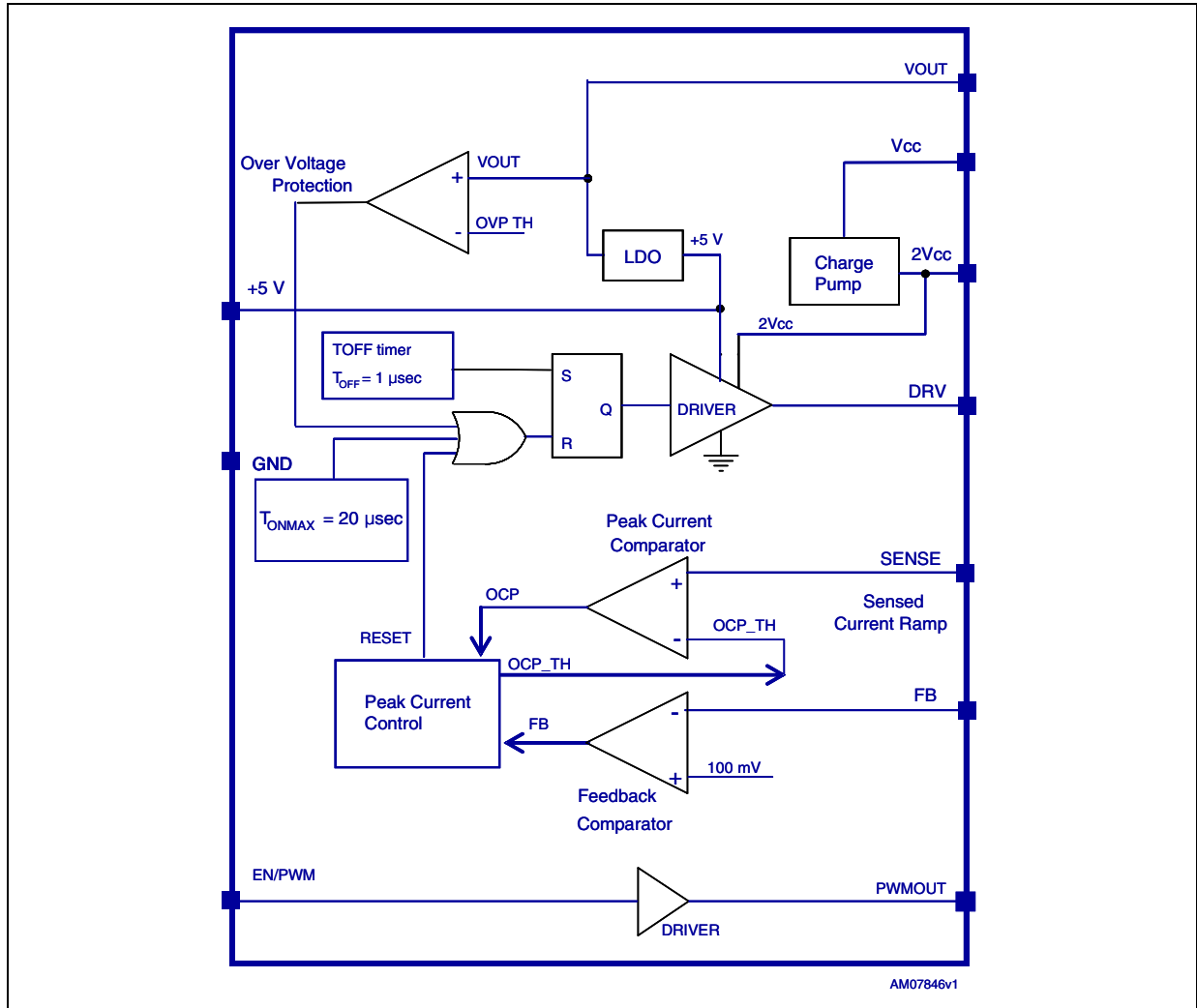

Figure 15.  $V_{CC} = 3.6\text{ V}$ ;  $I_{LED} = 300\text{ mA}$ , 4LEDs



# 6 Block diagram

Figure 16. Block diagram



## 7 Detailed description

### 7.1 Main control loop

The STLDC08 is an LED driver step-up controller dedicated to handheld equipment, having a typical voltage ranging from 0.8 V to 1.5 V. The controller drives an N-channel Power MOSFET and implements a hysteretic current mode control with constant OFF time. Hysteretic operation eliminates the need for small signal control loop compensation. The control loop adapts the value of the inductor peak current as needed to deliver the desired current on the LED branch. The LED current is set by an external sense resistor  $R_{FB}$  inserted between the feedback pin (FB) and GND. When the current mode control system operates in continuous mode the control peak current is almost equivalent to the average current control.

### 7.2 Start up

At the startup phase, when the device is connected to the battery or when the EN pin is pulled high, the internal 2x charge pump starts to work, boosting the voltage on the  $2V_{CC}$  pin. When the  $2V_{CC}$  pin reaches 1.7 V a soft-start cycle begins. The external main MOSFET is switched on/off allowing the charging of the output capacitor.

If the optional PWMOUT MOSFET is used for the dimming operation, the PWMOUT pin is held low, further assuring that no current is flowing. The PWMOUT pin starts to follow the PWM input when the soft-start cycle is ended.

When  $V_{OUT}$  voltage exceeds 1.9 V, the chip starts drawing its supply current from  $V_{OUT}$  rather than from  $V_{CC}$ , the charge pump is turned off and the voltage on the  $2V_{CC}$  pin goes to zero. When  $V_{OUT}$  exceeds the forward voltage of LED  $V_{LED}$ , the current starts flowing through the LED, but, at this point, the voltage on the DRV pin is high enough to allow the main MOSFET to carry the necessary current.

Figure 17. Timing diagram

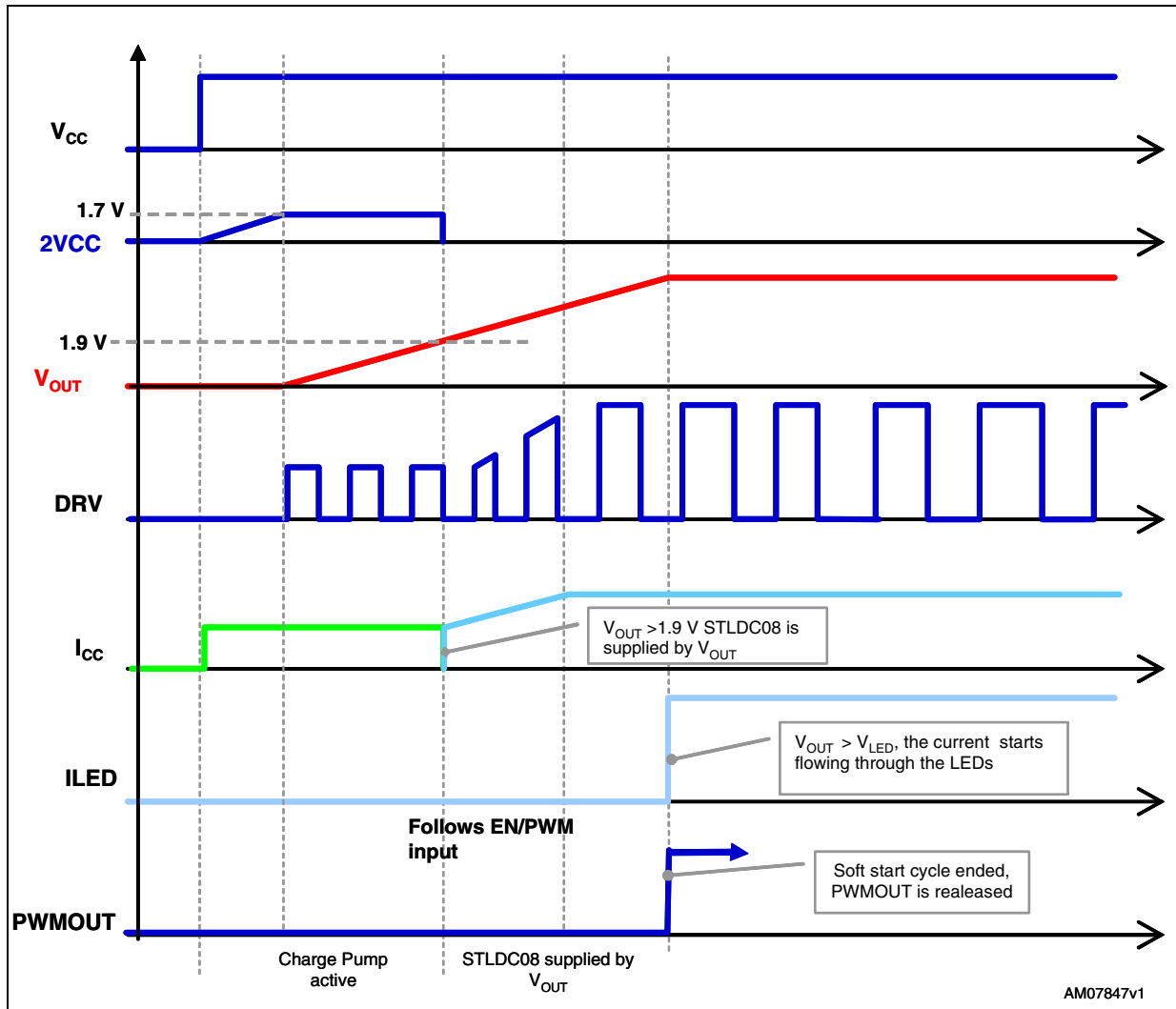

### 7.3 Over voltage protection (OVP)

As with any current source, the output voltage rises when the output gets high impedance or is disconnected. To prevent the output voltage exceeding the maximum switch voltage rating of the main switch, an overvoltage protection circuit is integrated. As soon as the output voltage exceeds the OVP threshold, the converter stops switching and the output voltage drops. When the output voltage falls below the OVP threshold, the converter continues operation until the output voltage exceeds the OVP threshold again.

### 7.4 Enable/PWM

The enable pin allows disabling and enabling of the device as well as brightness control of the LEDs by applying a PWM signal. In order to avoid visible flicker, the frequency of the PWM signal should be higher than 120 Hz. Changing the PWM duty cycle therefore changes the LED brightness.

## 7.5 Dimming

When PWMOUT goes to zero, the LED current immediately goes to zero and the energy stored in the coil is discharged on the output capacitor, causing an increase in the output voltage. As soon as the PWM goes back to high value, there is a big spike current on the LED. This could damage the LED itself. To avoid this, as soon as the input PWM signal goes to zero the controller immediately turns off the main switch (in order to discharge the coil current on the LED branch). In this way the PWM power is turned off with a delay in order to guarantee that FB goes high after PowerMOS turn off. After this delay, the flip-flop is ready to be set and the PWM power is turned off. In this condition the output voltage is slightly lower than the regulated value, but a current spike on the LED is avoided.

## 8 Application information

### 8.1 LED current programming

The LED current is set by an external resistor connected between the FB pin and GND. The following equation can be used to calculate the value of the  $R_{FB}$  resistor which guarantees the desired output current:

#### Equation 1

$$R_{FB} = \frac{0.1}{I_{LED}}$$

The feedback signal  $V_{FB}$  is compared with the internal precision 100 mV voltage reference by the error amplifier. The internal reference has a guaranteed tolerance of 10 %. Tolerance of the sense resistor adds additional error to the output voltage. 1 % resistors are recommended.

### 8.2 Duty cycle

The controlled off-time architecture is a hysteretic mode control. Hysteretic operation eliminates the need for small signal control loop compensation. When the converter runs in continuous conduction mode (CCM) the controller adapts the  $T_{ON}$  time in order to obtain the duty cycle given by the following relationship:

#### Equation 2

$$D = 1 - \frac{V_{IN}}{V_{OUT} + V_D}$$

where  $V_O$  is the output voltage given by:

#### Equation 3

$$V_O = n \times V_{F(LED)} + V_{FB}$$

and  $V_D$  is the forward voltage of the Schottky diode.

### 8.3 Inductor selection

As the hysteretic control scheme is inherently stable, the inductor value does not affect the stability of the regulator. The switching frequency, peak inductor current, and allowable ripple of the output current determine the value of the inductor.

LED manufacturers generally recommend a value for LED current ripple ranging from 5 % to 20 % of LED average current.

As a first approximation we choose the inductor ripple current,  $I_L$ , equal to approximately 40 % of the output current. Higher ripple current allows for smaller inductors, but it also increases the output capacitance for a given LED current ripple requirement. Conversely, lower ripple current can be obtained increasing the value of the inductance, and this enables a reduction of the output capacitor value. This trade-off can be altered once standard inductance and capacitance values are chosen.

$I_L$  is determined by the input and output voltage, the value of the inductance, and  $T_{OFF}$

Figure 18. Timing diagram

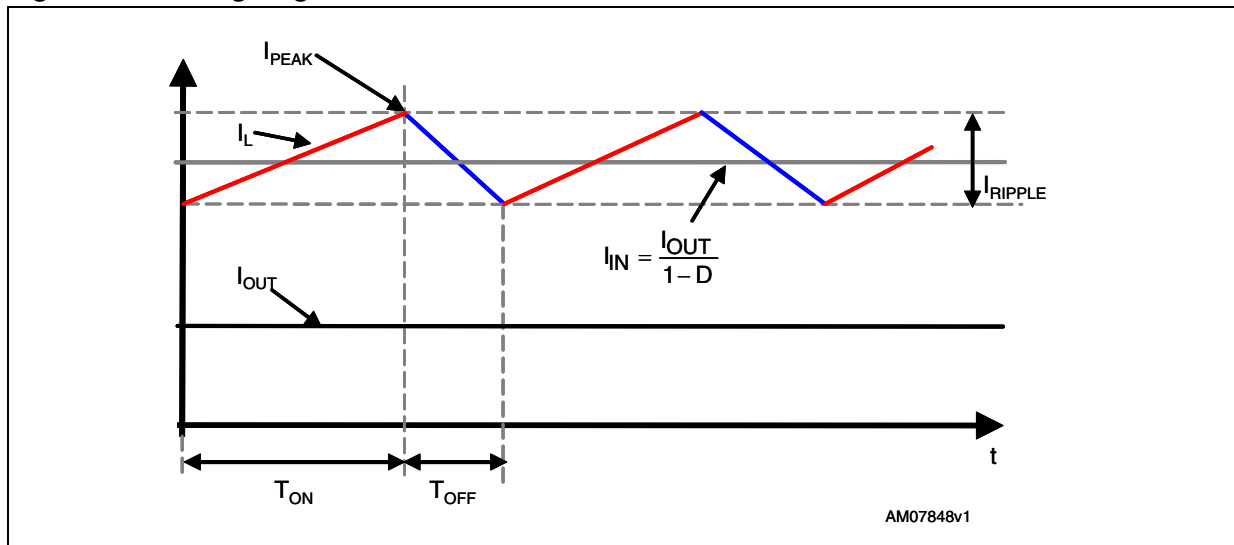

The minimum value of inductance which guarantees the fixed inductor ripple current can be determined using the following equation:

**Equation 4**

$$L > \frac{(V_{OUT} + V_d - V_{INMIN})}{(\Delta I_L)} \times T_{OFF}$$

where  $V_d$  is the forward drop of the Schottky diode,  $I_L$  is the fixed inductor ripple current, and  $T_{OFF}$  is the constant OFF time.

The following equation shows the average inductor current as a function of the output current and duty cycle.

**Equation 5**

$$I_{L(AVG)} = \frac{I_{LED}}{1-D}$$

An inductor that can carry the maximum input DC current which occurs at the minimum input voltage should be chosen. The peak-to-peak ripple current is set by the inductance and a good starting point is to choose a ripple current of at least 40 % of its maximum value of the:

**Equation 6**

$$\Delta I_L = 40\% \times I_{L(AVG)} = 40\% \times \frac{I_{LED}}{1 - D_{MAX}}$$

Where  $D_{MAX}$  is given by:

**Equation 7**

$$D_{MAX} = 1 - \frac{V_{IN(MIN)}}{V_{OUT} + V_D}$$

The value of the peak current on the inductor is given by the following equation:

**Equation 8**

$$I_{L(PK)} = I_{L(AVG)} + \frac{\Delta I_L}{2}$$

The minimum required saturation current of the inductor must be greater than  $I_{L(PK)}$  and can be expressed as follows:

**Equation 9**

$$I_{L(SAT)} > I_{L(PK)} = \frac{I_{OUT}}{1 - D_{MAX}} + \frac{\Delta I_L}{2}$$

The saturation current rating for the inductor should be checked at the maximum duty cycle and maximum output current.

## 8.4 Inductor peak current limit

The value of the inductor peak current limit can be programmed either by using a sense resistor or by using the  $R_{DS(ON)}$  of the main Power MOSFET.

The following equation gives the relationship between the peak current limit and the value of the sense resistor:

**Equation 10**

$$I_{IN(MAX)} = \frac{V_{SENSE}}{R_{SENSE}} = \frac{0.1}{R_{SENSE}}$$

The sense resistor value can be determined fixing the value of the inductor peak current limit equal to twice the value of the inductor peak current in steady-state conditions.

**Equation 11**

$$I_{N(MAX)} = 2 \times I_{L(PK)}$$

**Equation 12**

$$I_{L(PK)} = \frac{I_{LED}}{1 - D_{MAX}} + \frac{\Delta I_L}{2}$$

**Equation 13**

$$R_{SENSE} = \frac{0.1}{2 \times I_{L(PK)}}$$

If the  $R_{DS(ON)}$  of the main Power MOSFET is used to sense the current on the inductor the following procedure must be performed to choose the Power MOSFET. During ON time, the SENSE comparator limits the voltage across the Power MOSFET to a nominal 100 mV. In that case, the maximum inductor current is given by the following relationships:

**Equation 14**

$$I_{L(MAX)} = \frac{V_{SENSE}}{R_{DS(ON)}} = \frac{100mV}{R_{DS(ON)}}$$

**Equation 15**

$$I_{L(MAX)} = 2 \times I_{L(PK)} = 2 \times \frac{I_{LED}}{1 - D_{MAX}} \times \left(1 + \frac{\Delta I_L}{2}\right)$$

**Equation 16**

$$R_{DS(ON)} < 0.1 \times \frac{1 - D_{MAX}}{2 \times I_{LED} \times \left(1 + \frac{\Delta I_L}{2}\right)}$$

## 8.5 Power MOSFET selection

A key parameter to take into account in the selection of the N-MOSFET is the maximum continuous drain current. As a safety design, it is important to choose a maximum continuous drain current equal to twice the maximum input current.

Figure 19. Current diagram ON state

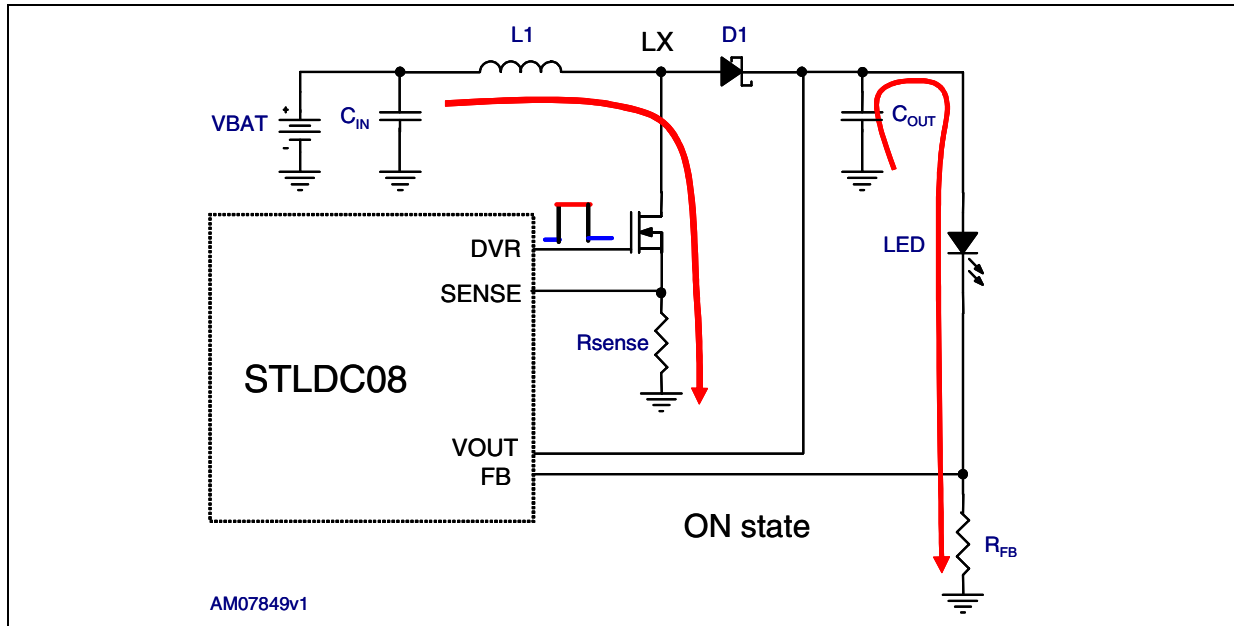

AM07849v1

Figure 20. Current diagram OFF state

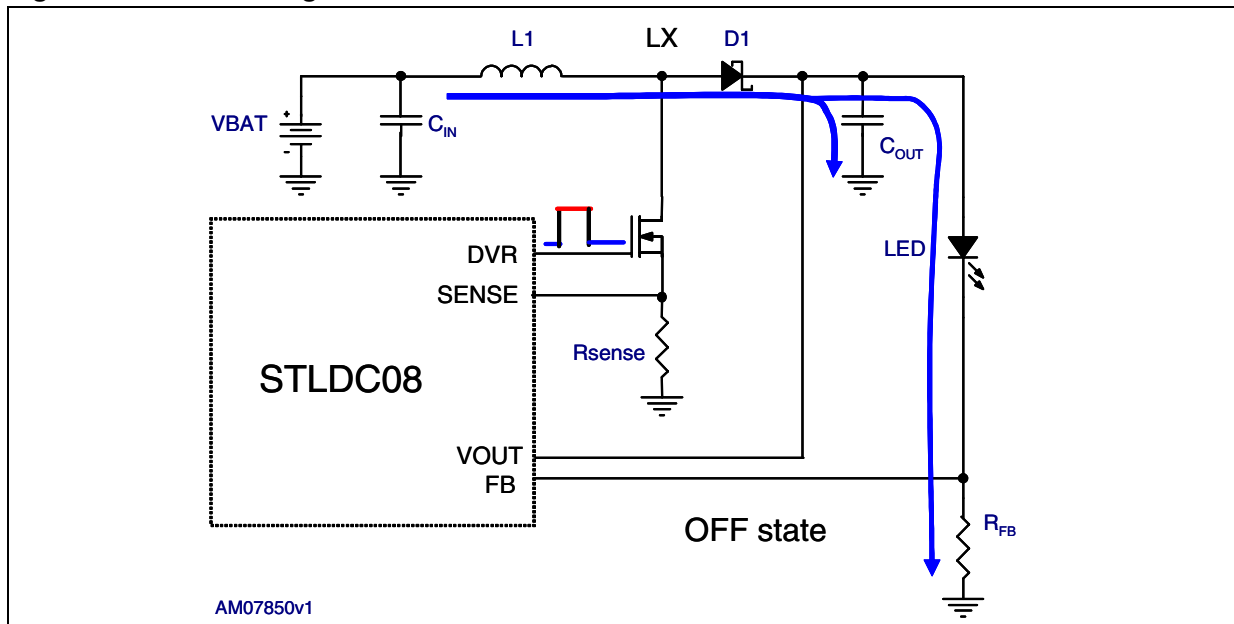

AM07850v1

Another important parameter is the drain source breakdown voltage. During the ON state, the potential of the LX point is 0 V, while during the OFF state the potential of this point rises to the output voltage plus the forward voltage of the D1. Therefore, the absolute  $V_{DS}$  rating of the main switch must be greater than this voltage to prevent main switch damage.

## 8.6 Schottky diode selection

Schottky diodes, with their low forward voltage and fast recovery time, are the ideal choice to maximize efficiency. The output diode in a boost converter conducts current only when the power switch is OFF. The average current is equal to the output current and the peak current is equal to the peak inductor current. Ensure that the diode's average and peak current ratings exceed the average and peak inductor current, respectively. In addition, the diode's reverse breakdown voltage must exceed the regulator output voltage.

## 8.7 Input capacitor

The input capacitor of a boost converter is less critical than the output capacitor, due to the fact that the input current waveform is continuous. The input voltage source impedance determines the size of the input capacitor, which is typically in the range of 10  $\mu\text{F}$  to 100  $\mu\text{F}$ . A low ESR capacitor is recommended though it is not as critical as the output capacitor.

## 8.8 Output capacitor

For best output voltage filtering, a low ESR output capacitor is recommended. Ceramic capacitors have a low ESR value but tantalum capacitors can be used as well, depending on the application.

The output voltage ripple consists of two parts, the first is the product  $I_{L(PK)} \text{ ESR}$ , the second is caused by the charging and discharging process of the output capacitor.

### Equation 17

$$\Delta V_{\text{OUT}} = \frac{T_{\text{ON}} \times I_{\text{LED}}}{C_{\text{OUT}}} + \text{ESR} \times I_{L(PK)}$$

where:

$I_{L(PK)}$  = Peak current

$I_{\text{LED}}$  = Load current

$C_{\text{OUT}}$  = Selected output capacitor

ESR = Output capacitor ESR value

# 9 Demonstration board

Figure 21. Electrical schematic

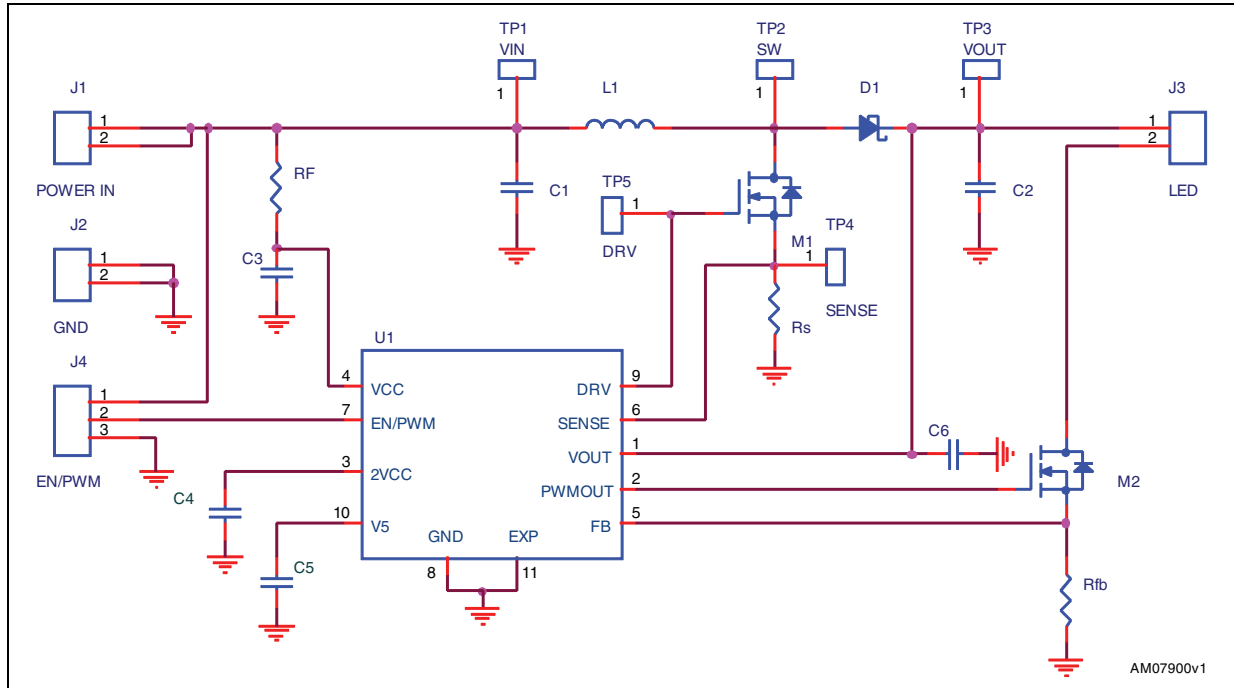

Table 8. Bill of material optimized for 2 LEDs and  $I_{LED} = 200 \text{ mA}$

| Reference  | Manufacturer       | Part number        | Value                  | Size        |
|------------|--------------------|--------------------|------------------------|-------------|
| C1         | Murata             | GRM21BR60J475      | 4.7 $\mu\text{F}$ 6.3V | 0805        |
| C2         | Murata             | GRM31CB31C106K     | 10 $\mu\text{F}$ 16 V  | 1206        |
| C4         | Murata             | GRM188R70J103KA01B | 10 nF, 6.3 V           | 0603        |
| C3, C5, C6 | Murata             | GRM188R61C105K     | 1 $\mu\text{F}$ , 16 V | 0603        |
| L          | Coilcraft          | LPS6235-103ML      | 10 $\mu\text{H}$       | 6 mm x 6 mm |
| M1,M2      | STMicroelectronics | STS5DNF20V         |                        | SO-8        |
| D1         | STMicroelectronics | STPS2L30           |                        | SMA         |
| Rfb        |                    |                    | 0.47 $\Omega$          | 0805        |
| Rs         |                    |                    | 0.047 $\Omega$         | 0805        |
| RF         |                    |                    | 0 $\Omega$             |             |

# 10 Layout suggestion

Figure 22. Assembly layer

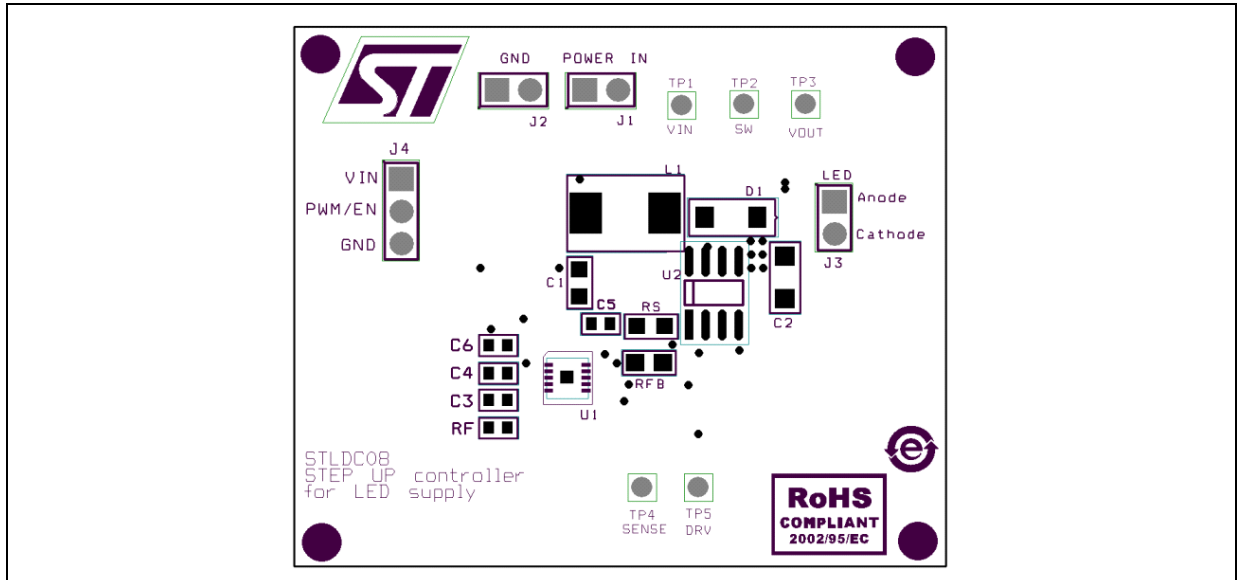

Figure 23. Top layer

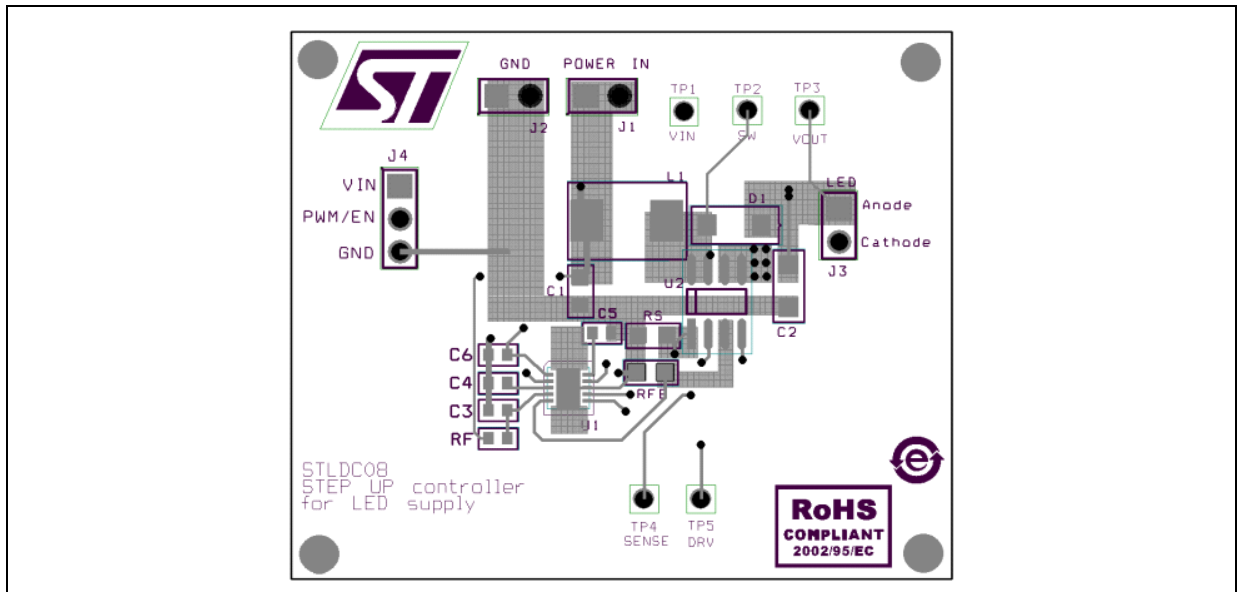
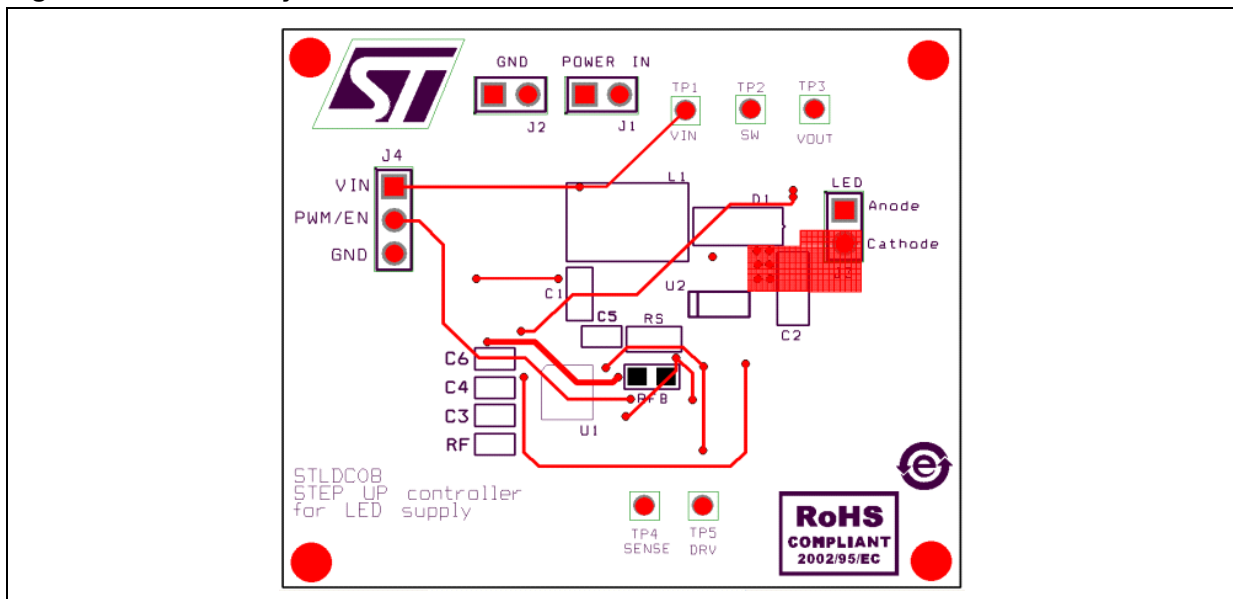

Figure 24. Bottom layer



## 11 Package mechanical data

In order to meet environmental requirements, ST offers these devices in different grades of ECOPACK® packages, depending on their level of environmental compliance. ECOPACK® specifications, grade definitions and product status are available at: [www.st.com](http://www.st.com). ECOPACK® is an ST trademark.

**DFN10 (3x3 mm) mechanical data**

| Dim. | mm.  |      |      | mils. |       |       |
|------|------|------|------|-------|-------|-------|
|      | Min. | Typ. | Max. | Min.  | Typ.  | Max.  |
| A    | 0.80 | 0.90 | 1.00 | 31.5  | 35.4  | 39.4  |
| A1   |      | 0.02 | 0.05 |       | 0.8   | 2.0   |
| A2   | 0.55 | 0.65 | 0.80 | 21.7  | 25.6  | 31.5  |
| A3   |      | 0.20 |      |       | 7.9   |       |
| b    | 0.18 | 0.25 | 0.30 | 7.1   | 9.8   | 11.8  |
| D    | 2.85 | 3.00 | 3.15 | 112.2 | 118.1 | 124.0 |
| D2   | 2.20 |      |      | 86.6  |       |       |
| E    | 2.85 | 3.00 | 3.15 | 112.2 | 118.1 | 124.0 |
| E2   | 1.40 |      | 1.75 | 55.1  |       | 68.9  |
| e    |      | 0.50 |      |       | 19.7  |       |
| L    | 0.30 | 0.40 | 0.50 | 11.8  | 15.7  | 19.7  |
| ddd  |      |      | 0.08 |       |       | 3.1   |

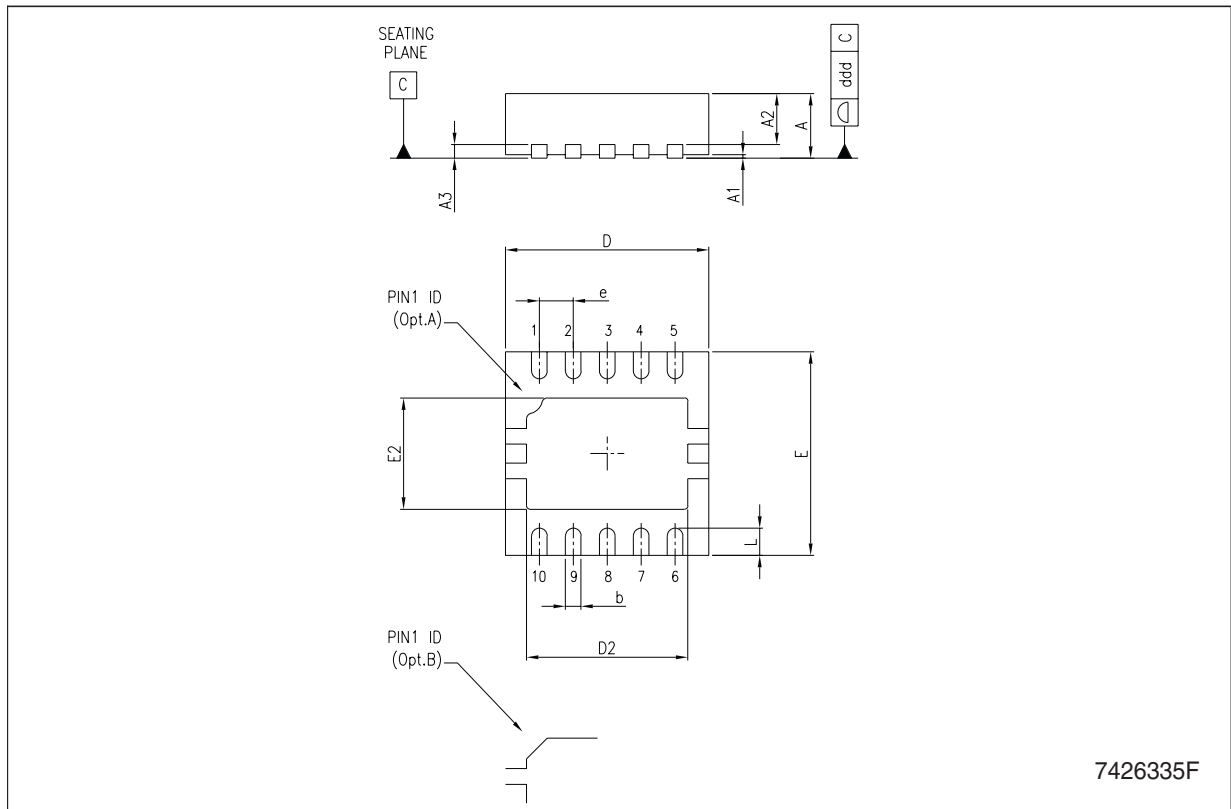

**Tape & reel QFNxx/DFNxx (3x3) mechanical data**

| Dim. | mm.  |      |      | inch. |       |       |
|------|------|------|------|-------|-------|-------|
|      | Min. | Typ. | Max. | Min.  | Typ.  | Max.  |
| A    |      |      | 180  |       |       | 7.087 |
| C    | 12.8 |      | 13.2 | 0.504 |       | 0.519 |
| D    | 20.2 |      |      | 0.795 |       |       |
| N    | 60   |      |      | 2.362 |       |       |
| T    |      |      | 14.4 |       |       | 0.567 |
| Ao   |      | 3.3  |      |       | 0.130 |       |
| Bo   |      | 3.3  |      |       | 0.130 |       |
| Ko   |      | 1.1  |      |       | 0.043 |       |
| Po   |      | 4    |      |       | 0.157 |       |
| P    |      | 8    |      |       | 0.315 |       |

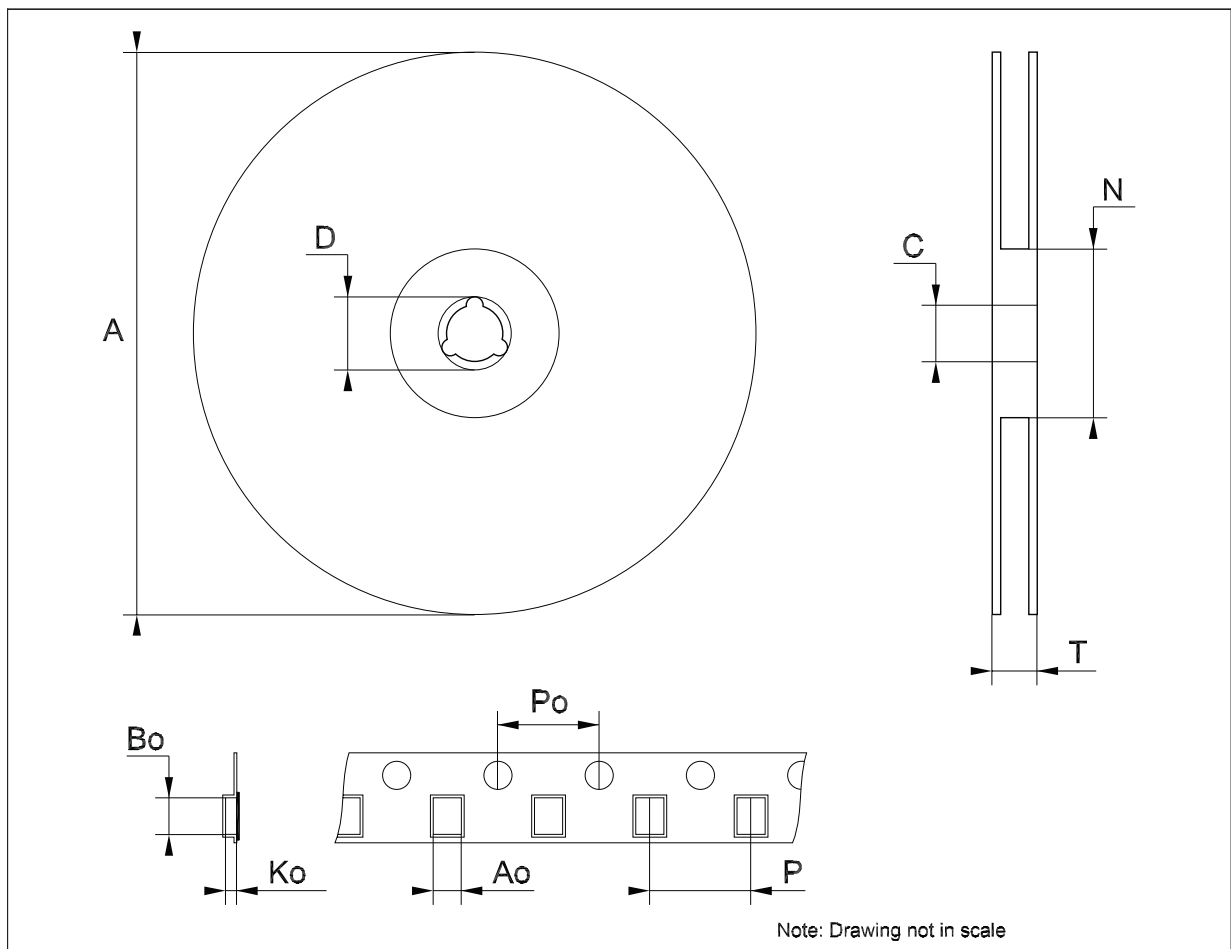

## 12 Revision history

**Table 9. Document revision history**

| Date        | Revision | Changes        |
|-------------|----------|----------------|
| 22-Feb-2011 | 1        | First release. |

**Please Read Carefully:**

Information in this document is provided solely in connection with ST products. STMicroelectronics NV and its subsidiaries ("ST") reserve the right to make changes, corrections, modifications or improvements, to this document, and the products and services described herein at any time, without notice.

All ST products are sold pursuant to ST's terms and conditions of sale.

Purchasers are solely responsible for the choice, selection and use of the ST products and services described herein, and ST assumes no liability whatsoever relating to the choice, selection or use of the ST products and services described herein.

No license, express or implied, by estoppel or otherwise, to any intellectual property rights is granted under this document. If any part of this document refers to any third party products or services it shall not be deemed a license grant by ST for the use of such third party products or services, or any intellectual property contained therein or considered as a warranty covering the use in any manner whatsoever of such third party products or services or any intellectual property contained therein.

**UNLESS OTHERWISE SET FORTH IN ST'S TERMS AND CONDITIONS OF SALE ST DISCLAIMS ANY EXPRESS OR IMPLIED WARRANTY WITH RESPECT TO THE USE AND/OR SALE OF ST PRODUCTS INCLUDING WITHOUT LIMITATION IMPLIED WARRANTIES OF MERCHANTABILITY, FITNESS FOR A PARTICULAR PURPOSE (AND THEIR EQUIVALENTS UNDER THE LAWS OF ANY JURISDICTION), OR INFRINGEMENT OF ANY PATENT, COPYRIGHT OR OTHER INTELLECTUAL PROPERTY RIGHT.**

**UNLESS EXPRESSLY APPROVED IN WRITING BY AN AUTHORIZED ST REPRESENTATIVE, ST PRODUCTS ARE NOT RECOMMENDED, AUTHORIZED OR WARRANTED FOR USE IN MILITARY, AIR CRAFT, SPACE, LIFE SAVING, OR LIFE SUSTAINING APPLICATIONS, NOR IN PRODUCTS OR SYSTEMS WHERE FAILURE OR MALFUNCTION MAY RESULT IN PERSONAL INJURY, DEATH, OR SEVERE PROPERTY OR ENVIRONMENTAL DAMAGE. ST PRODUCTS WHICH ARE NOT SPECIFIED AS "AUTOMOTIVE GRADE" MAY ONLY BE USED IN AUTOMOTIVE APPLICATIONS AT USER'S OWN RISK.**

Resale of ST products with provisions different from the statements and/or technical features set forth in this document shall immediately void any warranty granted by ST for the ST product or service described herein and shall not create or extend in any manner whatsoever, any liability of ST.

ST and the ST logo are trademarks or registered trademarks of ST in various countries.

Information in this document supersedes and replaces all information previously supplied.

The ST logo is a registered trademark of STMicroelectronics. All other names are the property of their respective owners.

© 2011 STMicroelectronics - All rights reserved

STMicroelectronics group of companies

Australia - Belgium - Brazil - Canada - China - Czech Republic - Finland - France - Germany - Hong Kong - India - Israel - Italy - Japan - Malaysia - Malta - Morocco - Philippines - Singapore - Spain - Sweden - Switzerland - United Kingdom - United States of America

[www.st.com](http://www.st.com)

# AMEYA360

## Components Supply Platform

### Authorized Distribution Brand :



### Website :

Welcome to visit [www.ameya360.com](http://www.ameya360.com)

### Contact Us :

#### ➤ Address :

401 Building No.5, JiuGe Business Center, Lane 2301, Yishan Rd  
Minhang District, Shanghai , China

#### ➤ Sales :

Direct +86 (21) 6401-6692

Email [amall@ameya360.com](mailto:amall@ameya360.com)

QQ 800077892

Skype [ameyasales1](#) [ameyasales2](#)

#### ➤ Customer Service :

Email [service@ameya360.com](mailto:service@ameya360.com)

#### ➤ Partnership :

Tel +86 (21) 64016692-8333

Email [mkt@ameya360.com](mailto:mkt@ameya360.com)