



FSA3000 — Two-Port, High-Speed, MHL™ Switch

Features

- Low On Capacitance: 2.7 pF/4.1 pF MHL/USB (Typical)
- Low Power Consumption: 30 μ A Maximum
- MHL Data Rate: 4.92 Gbps ($f_{3dB} = 2.46$ GHz)
- Packaged in 10-Lead MicroPak™
- Over-Voltage Tolerance (OVT) on all USB and MHL Ports; Up to 5.25 V without External Components

Applications

- Cell Phones and Digital Cameras

Description

The FSA3000 is a bi-directional, low-power, two-port, high-speed, USB2.0 and video data switch that supports the Mobile High-Definition Link (MHL) Specification Rev. 2.0. Configured as a double-pole, double-throw (DPDT) switch for data, FSA3000 is optimized for USB2.0 and MHL data sources.

The FSA3000 contains circuitry on the switch I/O pins that allows the device to withstand an over-voltage condition in applications where the V_{CC} supply is powered off ($V_{CC}=0$). The FSA3000 minimizes current consumption even when the voltage applied to the control pins is lower than the supply voltage (V_{CC}). This feature is especially valuable in mobile applications, such as cell phones; allowing direct interface with the general-purpose I/Os of the baseband processor. Other applications include switching and connector sharing in portable cell phones, digital cameras, and notebook computers.

Ordering Information

Part Number	Top Mark	Operating Temperature Range	Package
FSA3000L10X	LK	-40 to +85°C	10-Lead, MicroPak™ 1.6 x 2.1 mm JEDEC MO255B
FSA3000L10X_F131	LK		10-Lead, MicroPak™ 1.6 x 2.1 mm JEDEC MO255B, Package Rotated 90° in Tape and Reel

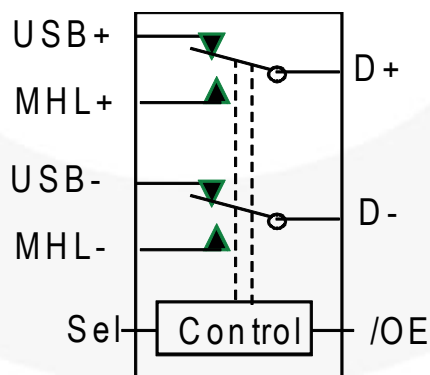

Figure 1. Analog Symbol

All trademarks are the property of their respective owners.

Data Switch Select Truth Table

SEL ⁽¹⁾	/OE ⁽¹⁾	Function
X	HIGH	USB and MHL paths both high impedance
LOW	LOW	D+/D- connected to USB+/USB-
HIGH	LOW	D+/D- connected to MHL+/MHL-

Note:

- Control inputs should never be left floating or unconnected.

Pin Configurations

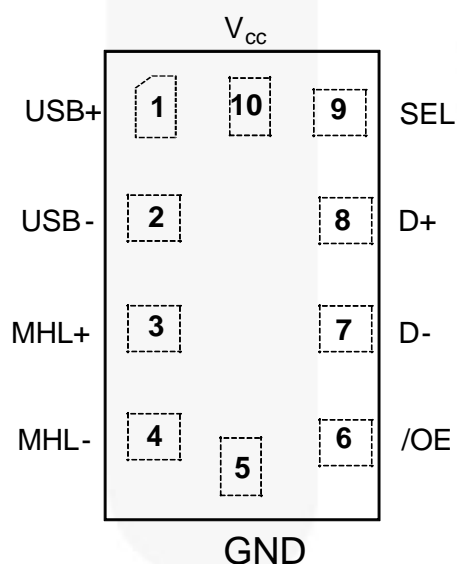

Figure 2. Pin Assignments (Top-Through View)

Pin Definitions

Pin#	Name	Description
1	USB+	USB Differential Data (Positive)
2	USB-	USB Differential Data (Negative)
3	MHL+	MHL Differential Data (Positive)
4	MHL-	MHL Differential Data (Negative)
5	GND	Ground
6	/OE	Output Enable (Active LOW)
7	D-	Data Switch Output (Negative)
8	D+	Data Switch Output (Positive)
9	SEL	Data Switch Select
10	V _{CC}	Supply

Absolute Maximum Ratings

Stresses exceeding the absolute maximum ratings may damage the device. The device may not function or be operable above the recommended operating conditions and stressing the parts to these levels is not recommended. In addition, extended exposure to stresses above the recommended operating conditions may affect device reliability. The absolute maximum ratings are stress ratings only.

Symbol	Parameter		Min.	Max.	Unit
V _{CC}	Supply Voltage		-0.5	5.5	V
V _{CNTRL}	DC Input Voltage (SEL, /OE) ⁽²⁾		-0.5	V _{CC}	V
V _{SW}	DC Switch I/O Voltage ^(2,3)		-0.50	5.25	V
I _{IK}	DC Input Diode Current		-50		mA
I _{OUT}	DC Output Current			100	mA
T _{STG}	Storage Temperature		-65	+150	°C
MSL	Moisture Sensitivity Level (JEDEC J-STD-020A)			1	
ESD	Human Body Model, JEDEC: JESD22-A114	All Pins		3.5	kV
	IEC 61000-4-2, Level 4, for D+/D- and V _{CC} Pins ⁽⁴⁾	Contact		8	
	IEC 61000-4-2, Level 4, for D+/D- and V _{CC} Pins ⁽⁴⁾	Air		15	
	Charged Device Model, JESD22-C101			2	

Notes:

- The input and output negative ratings may be exceeded if the input and output diode current ratings are observed.
- V_{SW} refers to analog data switch paths (USB and MHL).
- Testing performed in a system environment using TVS diodes.

Recommended Operating Conditions

The Recommended Operating Conditions table defines the conditions for actual device operation. Recommended operating conditions are specified to ensure optimal performance to the datasheet specifications. Fairchild does not recommend exceeding them or designing to Absolute Maximum Ratings.

Symbol	Parameter	Min.	Max.	Unit
V _{CC}	Supply Voltage	2.7	4.3	V
t _{RAMP(VCC)}	Power Supply Slew Rate	100	1000	µs/V
V _{CNTRL}	Control Input Voltage (SEL, /OE) ⁽⁵⁾	0	4.3	V
θ _{JA}	Thermal Resistance		313	C°/W
V _{SW(USB)}	Switch I/O Voltage (USB Switch Path)	-0.5	3.6	V
V _{SW(MHL)}	Switch I/O Voltage (MHL Switch Path)	1.65	3.45	V
T _A	Operating Temperature	-40	+85	°C

Note:

- The control inputs must be held HIGH or LOW; they must not float.

DC Electrical Characteristics

All typical value are at $T_A=25^\circ\text{C}$ unless otherwise specified.

Symbol	Parameter	Condition	V_{CC} (V)	$T_A = -40^\circ\text{C}$ to $+85^\circ\text{C}$			Unit
				Min.	Typ.	Max.	
V_{IK}	Clamp Diode Voltage	$I_{IN} = -18\text{ mA}$	2.7			-1.2	V
V_{IH}	Control Input Voltage High	SEL, /OE	2.7 to 4.3	1.25			V
V_{IL}	Control Input Voltage Low	SEL, /OE	2.7 to 4.3			0.6	V
I_{IN}	Control Input Leakage	$V_{SW}=0$ to 3.6 V, $V_{CNTRL}=0$ to V_{CC}	4.3	-500		500	nA
$I_{OZ(MHL)}$	Off-State Leakage for Open MHLn Data Paths	$V_{SW}=1.65 \leq \text{MHL} \leq 3.45\text{ V}$	4.3	-500		500	nA
$I_{OZ(USB)}$	Off-State Leakage for Open USBn Data Paths	$V_{SW}=0 \leq \text{USB} \leq 3.6\text{ V}$	4.3	-500		500	nA
$I_{CL(MHL)}$	On-State Leakage for Closed MHLn Data Paths ⁽⁶⁾	$V_{SW}=1.65 \leq \text{MHL} \leq 3.45\text{ V}$	4.3	-500		500	nA
$I_{CL(USB)}$	On-State Leakage for Closed USBn Data Paths ⁽⁶⁾	$V_{SW}=0 \leq \text{USB} \leq 3.6\text{ V}$	4.3	-500		500	nA
I_{OFF}	Power-Off Leakage Current (All I/O Ports)	$V_{SW}=0\text{ V}$ or 3.6 V, Figure 4	0	-500		500	nA
$R_{ON(USB)}$	HS Switch On Resistance (USB to Dn Path)	$V_{SW}=0.4\text{ V}$, $I_{ON}=-8\text{ mA}$, Figure 3	2.7		3.5	4.8	Ω
$R_{ON(MHL)}$	HS Switch On Resistance (MHL to Dn Path)	$V_{SW}=V_{CC}-1050\text{ mV}$, $I_{ON}=-8\text{ mA}$, Figure 3	2.7		4.7	6.0	Ω
$\Delta R_{ON(MHL)}$	Difference in R_{ON} Between MHL Positive-Negative	$V_{SW}=V_{CC}-1050\text{ mV}$, $I_{ON}=-8\text{ mA}$, Figure 3,	2.7		0.03		Ω
$\Delta R_{ON(USB)}$	Difference in R_{ON} Between USB Positive-Negative	$V_{SW}=0.4\text{ V}$, $I_{ON}=-8\text{ mA}$, Figure 3	2.7		0.18		Ω
$R_{ONF(MHL)}$	Flatness for R_{ON} MHL Path	$V_{SW}=1.65$ to 3.45 V, $I_{ON}=-8\text{ mA}$, Figure 3	2.7		0.9		Ω
I_{CC}	Quiescent Supply Current	$V_{IOE}=0$, $V_{SEL}=0$ or V_{CC} , $I_{OUT}=0$	4.3			30	μA
I_{CCZ}	Quiescent Supply Current (High Impedance)	$V_{SEL}=X$, $V_{IOE}=V_{CC}$, $I_{OUT}=0$	4.3			1	μA
I_{CCT}	Increase in Quiescent Supply Current	$V_{SEL}=X$, $V_{IOE}=1.65\text{ V}$	4.3		5	10	μA

Note:

6. For this test, the data switch is closed with the respective switch pin floating.

AC Electrical Characteristics

All typical value are for $V_{CC}=3.3\text{ V}$ and $T_A=25^\circ\text{C}$ unless otherwise specified.

Symbol	Parameter	Condition	V_{CC} (V)	$T_A = -40^\circ\text{C}$ to $+85^\circ\text{C}$			Unit
				Min.	Typ.	Max.	
t_{ON}	MHL Turn-On Time, SEL to Output	$R_L=50\ \Omega$, $C_L=5\ \text{pF}$, $V_{SW(USB)}=0.8\ \text{V}$, $V_{SW(MHL)}=3.3\ \text{V}$, Figure 5, Figure 6	2.7 to 3.6 V		350	600	ns
t_{OFF}	MHL Turn-Off Time, SEL to Output	$R_L=50\ \Omega$, $C_L=5\ \text{pF}$, $V_{SW(USB)}=0.8\ \text{V}$, $V_{SW(MHL)}=3.3\ \text{V}$, Figure 5, Figure 6	2.7 to 3.6 V		125	300	ns
$t_{ZHM,ZLM}$	MHL Enable Time, /OE to Output	$R_L=50\ \Omega$, $C_L=5\ \text{pF}$, $V_{SW(MHL)}=3.3\ \text{V}$, Figure 5, Figure 6	2.7 to 3.6 V		60	150	μs
$t_{ZHU,ZLU}$	USB Enable Time, /OE to Output	$R_L=50\ \Omega$, $C_L=5\ \text{pF}$, $V_{SW(USB)}=0.8\ \text{V}$, Figure 5, Figure 6	2.7 to 3.6 V		100	300	ns
$t_{LZM,HZM}$	MHL Disable Time, /OE to Output	$R_L=50\ \Omega$, $C_L=5\ \text{pF}$, $V_{SW(MHL)}=3.3\ \text{V}$, Figure 5, Figure 6	2.7 to 3.6 V		35	100	ns
$t_{LZU,HZU}$	USB Disable Time, /OE to Output	$R_L=50\ \Omega$, $C_L=5\ \text{pF}$, $V_{SW(USB)}=0.8\ \text{V}$, Figure 5, Figure 6	2.7 to 3.6 V		35	100	ns
t_{PD}	Propagation Delay ⁽⁷⁾	$C_L=5\ \text{pF}$, $R_L=50\ \Omega$, Figure 5, Figure 7	2.7 to 3.6 V		0.25		ns
t_{BBM}	Break-Before-Make ⁽⁷⁾	$R_L=50\ \Omega$, $C_L=5\ \text{pF}$, $V_{ID}=V_{MHL}=3.3\ \text{V}$, $V_{USB}=0.8\ \text{V}$, Figure 9	2.7 to 3.6 V	2		13	ns
$O_{IRR(MHL)}$	Off Isolation ⁽⁷⁾	$V_S=1\ \text{V}_{pk-pk}$, $R_L=50\ \Omega$, $f=240\ \text{MHz}$, Figure 11	2.7 to 3.6 V		-55		dB
$O_{IRR(USB)}$		$V_S=400\ \text{mV}_{pk-pk}$, $R_L=50\ \Omega$, $f=240\ \text{MHz}$, Figure 11	2.7 to 3.6 V		-45		dB
$Xtalk_{MHL}$	Non-Adjacent Channel ⁽⁷⁾ Crosstalk	$V_S=1\ \text{V}_{pk-pk}$, $R=50\ \Omega$, $f=240\ \text{MHz}$, Figure 12	2.7 to 3.6 V		-47		dB
$Xtalk_{USB}$		$V_S=400\ \text{mV}_{pk-pk}$, $R_L=50\ \Omega$, $f=240\ \text{MHz}$, Figure 12	2.7 to 3.6 V		-45		dB
BW (Insertion Loss)	Differential -3db Bandwidth ⁽⁷⁾	$V_{IN}=1\ \text{V}_{pk-pk}$, MHL Path, $R_L=50\ \Omega$, $C_L=0\ \text{pF}$, Figure 10, Figure 15	2.7 to 3.6 V		2.46		GHz
		$V_{IN}=400\ \text{mV}_{pk-pk}$, USB Path, $R_L=50\ \Omega$, $C_L=0\ \text{pF}$, Figure 10, Figure 16			1.22		

Note:

7. Guaranteed by characterization.

USB High-Speed AC Electrical Characteristics

Typical values are for $V_{CC}=3.3$ V and $T_A=25^\circ\text{C}$ unless otherwise specified.

Symbol	Parameter	Condition	V_{CC} (V)	Typ.	Unit
$t_{SK(P)}$	Skew of Opposite Transitions of the Same Output ⁽⁸⁾	$C_L=5$ pF, $R_L=50$ Ω , Figure 8	3.0 to 3.6	6	ps
t_J	Total Jitter ⁽⁸⁾	$R_L=50$ Ω , $C_L=5$ pf, $t_R=t_F=500$ ps (10-90%) at 480 Mbps, PN7	3.0 to 3.6	15	ps

Note:

8. Guaranteed by characterization.

MHL AC Electrical Characteristics

Typical values are for $V_{CC}=3.3$ V and $T_A=25^\circ\text{C}$ unless otherwise specified.

Symbol	Parameter	Condition	V_{CC} (V)	Typ.	Unit
$t_{SK(P)}$	Skew of Opposite Transitions of the Same Output ⁽⁹⁾	$R_{PU}=50$ Ω to V_{CC} , $C_L=0$ pF	3.0 to 3.6 V	6	ps
t_J	Total Jitter ⁽⁹⁾	$f=2.25$ Gbps, PN7, $R_{PU}=50$ Ω to V_{CC} , $C_L=0$ pF	3.0 to 3.6 V	15	ps

Note:

9. Guaranteed by characterization.

Capacitance

Typical values are for $V_{CC}=3.3$ V and $T_A=25^\circ\text{C}$ unless otherwise specified.

Symbol	Parameter	Condition	Typ.	Max.	Unit
C_{IN}	Control Pin Input Capacitance ⁽¹⁰⁾	$V_{CC}=0$ V, $f=1$ MHz	2.1		pF
$C_{ON(USB)}$	USB Path On Capacitance ⁽¹⁰⁾	$V_{CC}=3.3$ V, $f=240$ MHz, Figure 14	4.1	5.0	pF
$C_{OFF(USB)}$	USB Path Off Capacitance ⁽¹⁰⁾	$V_{CC}=3.3$ V, $f=240$ MHz, Figure 13	2.8	3.2	pF
$C_{ON(MHL)}$	MHL Path On Capacitance ⁽¹⁰⁾	$V_{CC}=3.3$ V, $f=240$ MHz, Figure 14	2.7	3.0	pF
$C_{OFF(MHL)}$	MHL Path Off Capacitance ⁽¹⁰⁾	$V_{CC}=3.3$ V, $f=240$ MHz, Figure 13	1.1	1.5	pF

Note:

10. Guaranteed by characterization, not production tested.

Test Diagrams

Note:

11. HSD refers to the high-speed data on USB or MHL paths.

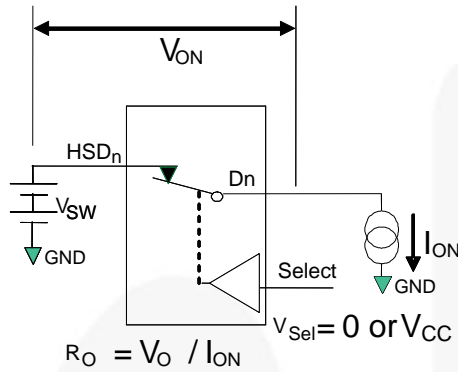
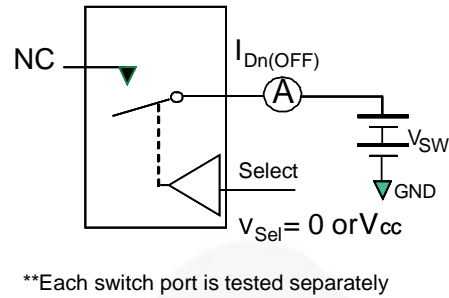
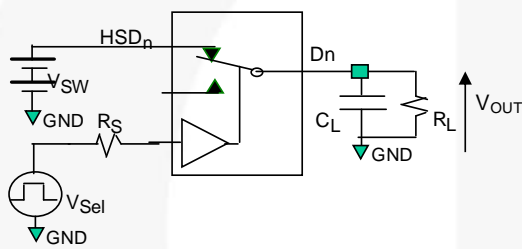

Figure 3. On Resistance



**Each switch port is tested separately

Figure 4. Off Leakage



R_L , R_S and C_L are function of application environment (see AC Tables for specific values)
 C_L includes test fixture and stray capacitance

Figure 5. AC Test Circuit Load

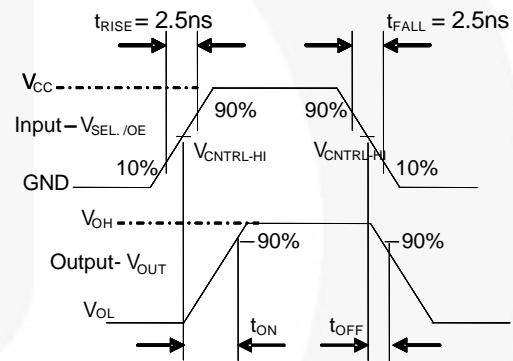

Figure 6. Turn-On / Turn-Off Waveforms

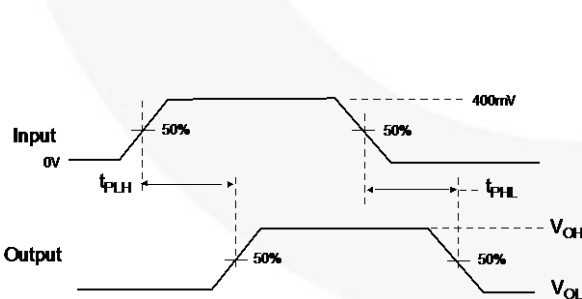

Figure 7. Propagation Delay ($t_{RTf} = 500$ ps)

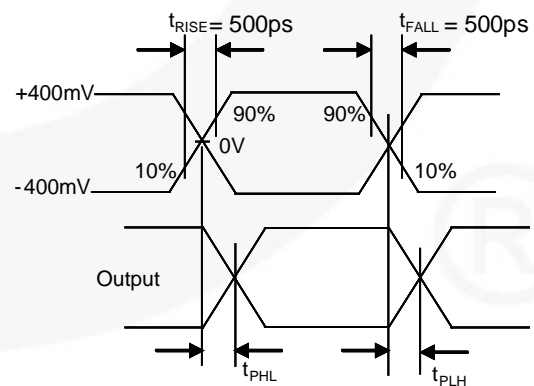
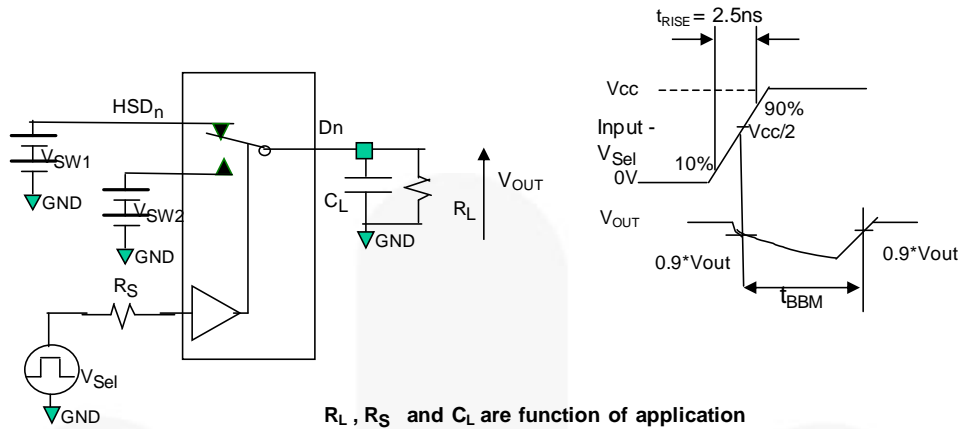

Figure 8. Intra-Pair Skew Test $t_{SK(P)}$

Test Diagrams (Continued)



R_L , R_S and C_L are function of application environment (see AC Tables for specific values)
 C_L includes test fixture and stray capacitance

Figure 9. Break-Before-Make Interval Timing

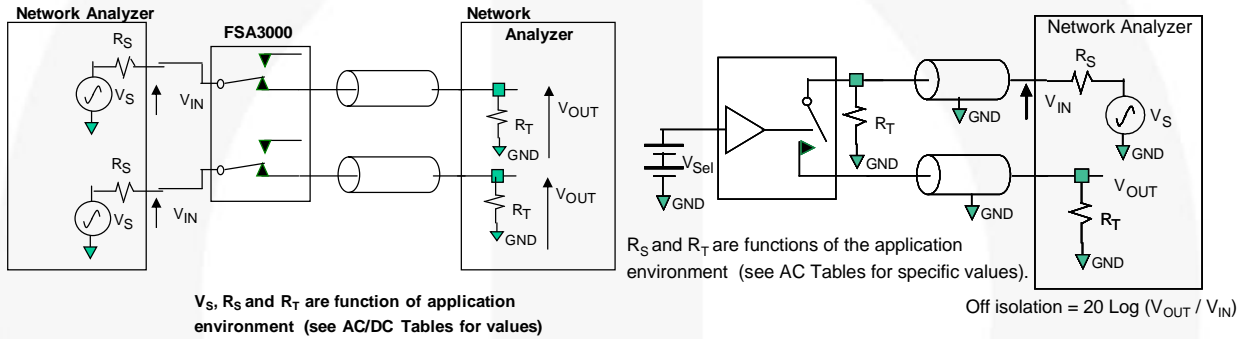

V_S , R_S and R_T are function of application environment (see AC/DC Tables for values)

Figure 10. Insertion Loss

Figure 11. Channel Off Isolation

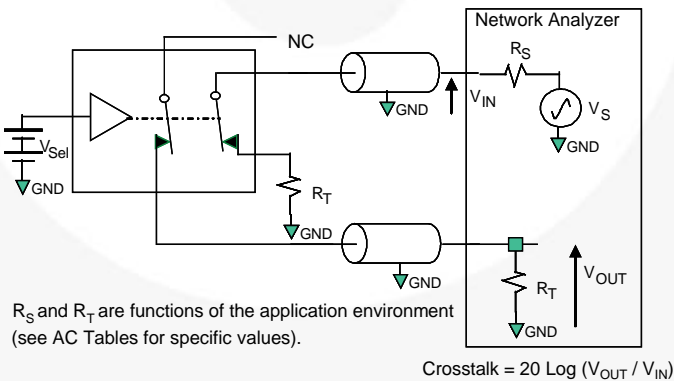

R_S and R_T are functions of the application environment (see AC Tables for specific values).

Crosstalk = $20 \text{ Log } (V_{OUT} / V_{IN})$

Figure 12. Non-Adjacent Channel-to-Channel Crosstalk

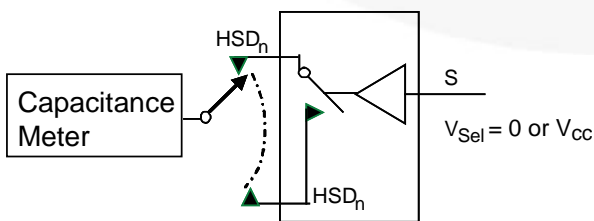

Figure 13. Channel Off Capacitance

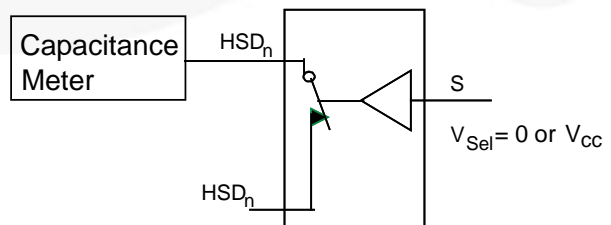

Figure 14. Channel On Capacitance

Insertion Loss

One of the key factors for the FSA3000 in mobile digital video applications is the small amount of insertion loss in the received signal as it passes through the switch. This results in minimal degradation of the received eye. One of the ways to measure the quality of the high data rate channels is using balanced ports and 4-port differential S-parameter analysis, particularly SDD21.

Bandwidth is measured using the S-parameter SDD21 methodology. Figure 15 shows the bandwidth (GHz) for the MHL path and Figure 16 shows the bandwidth curve for the USB path.

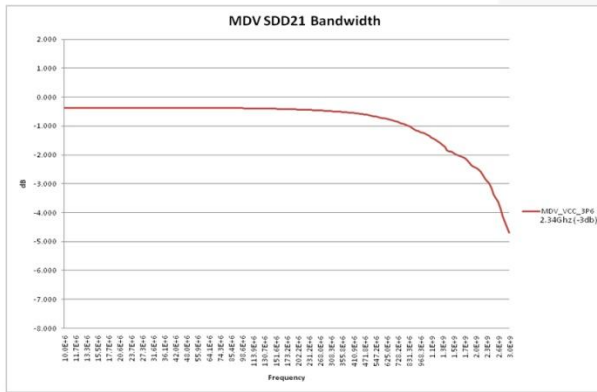

Figure 15. MHL (MDV) Path SDD21 Insertion Loss Curve

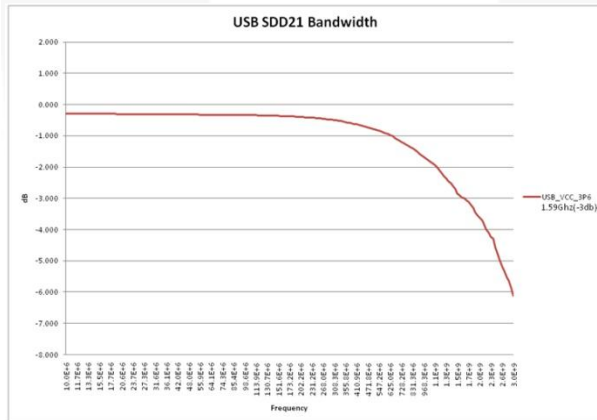

Figure 16. USB Path SDD21 Insertion Loss Curve

Typical Application

Figure 17 shows a typical mobile application using the FSA3000 for MHL switching. The FSA3157 is used for OTG dual-role device implementations where the CBUS of MHL and the ID pin for USB needs to be switched. The 3M resistor for MHL_SEL is optional to ensure that on power up the USB switch path is selected as default.

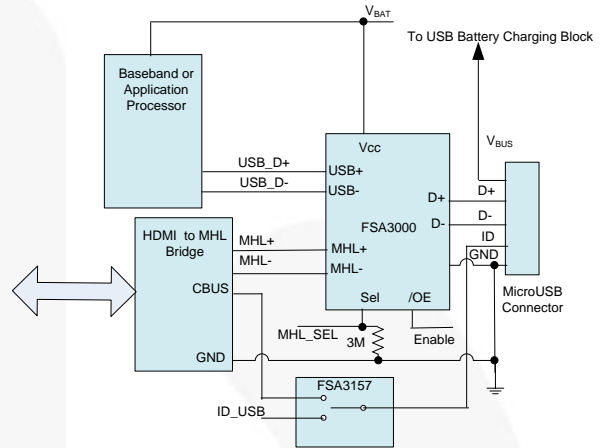

Figure 17. Typical Mobile MHL Application

Physical Dimensions

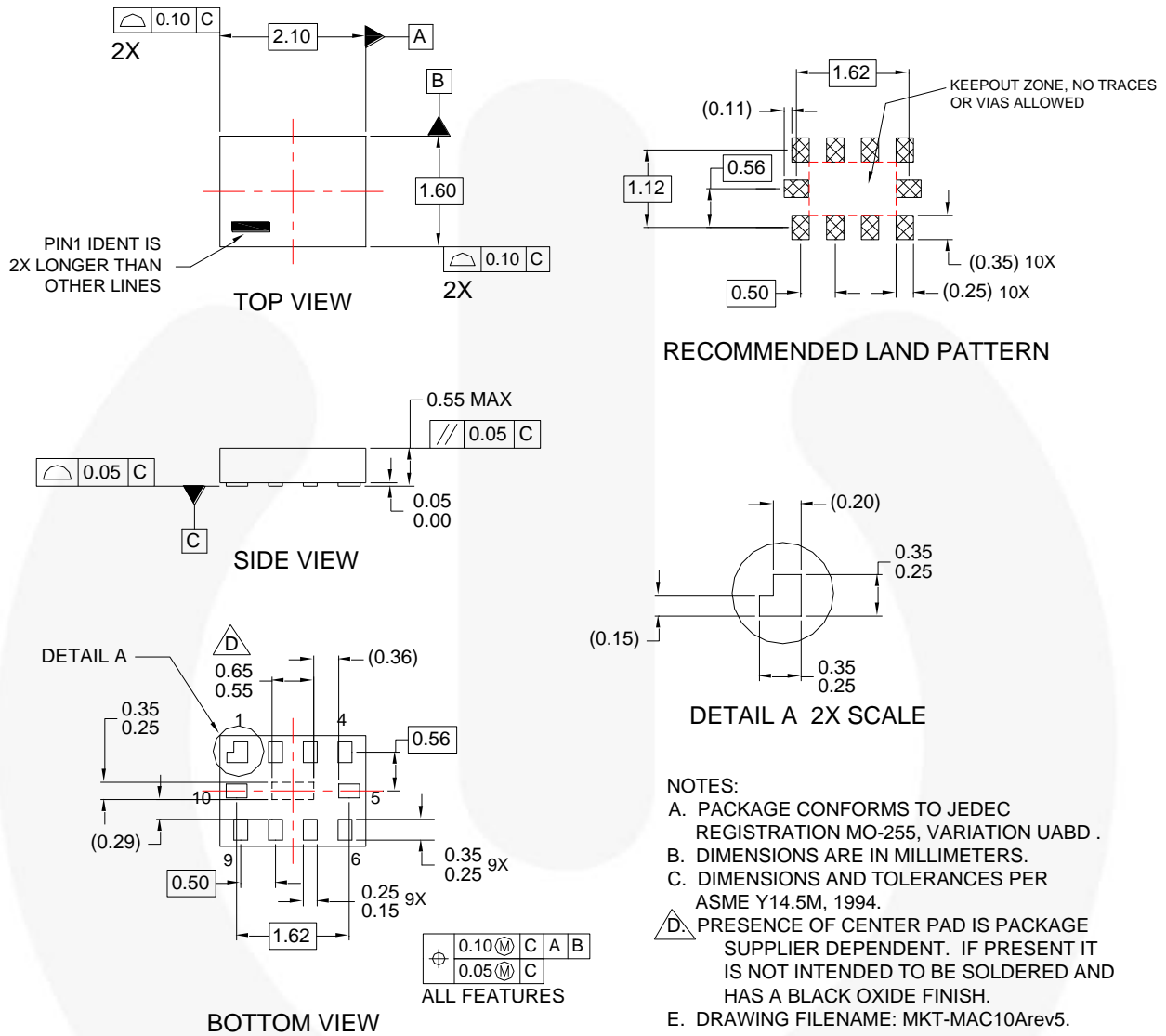

Figure 18. 10-Lead, MicroPak™ 1.6 x 2.1 mm JEDEC MO255B

Package drawings are provided as a service to customers considering Fairchild components. Drawings may change in any manner without notice. Please note the revision and/or date on the drawing and contact a Fairchild Semiconductor representative to verify or obtain the most recent revision. Package specifications do not expand the terms of Fairchild's worldwide terms and conditions, specifically the warranty therein, which covers Fairchild products.

Always visit Fairchild Semiconductor's online packaging area for the most recent package drawings:

<http://www.fairchildsemi.com/packaging/>

Packing Specifications

MicroPak 1.6x2.1 F131, Packing Drawing



Packing Description:

MicroPak 1.6x2.1 F131 products are classified under Moisture Sensitive Level 1.

The carrier tape is made from dissipative polystyrene or polycarbonate resin. The cover tape is a multilayer film primarily composed of polyester film, adhesive layer, heat activated sealant, and anti-static sprayed agent. These reeled parts in standard option are shipped with 5000 units per 178 mm diameter reel. Up to three reels are packed in each intermediate box. The reels is made of polystyrene plastic (anti-static coated or intrinsic).

These full reels are individually barcode labeled and placed inside a pizza box made of recyclable corrugated brown paper with a Fairchild logo printing. Up to 3 reels could be packed in the pizza box. And these pizza boxes are placed inside a barcode labeled shipping box which comes in different sizes depending on the number of parts shipped.

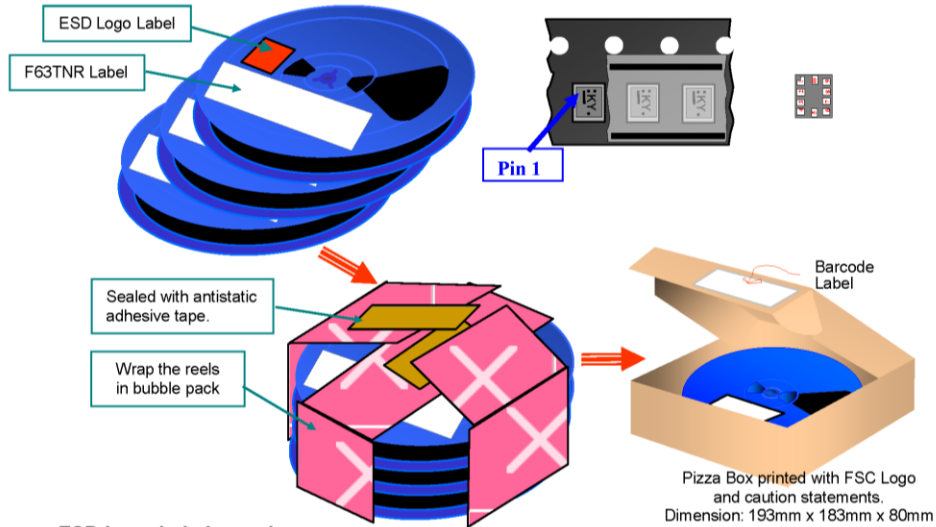

ESD Logo Label sample



F63TNR Label sample

LOT: PMH01008888	QTY: 5000
FSID: FSA831L10X	SPEC: F131
D/C1: P1136AA QTY1:	SPEC REV: 2 nd Level Interconnect
D/C2: QTY2:	1. Category G4
Green Component	2. Maximum safe temperature 260 deg C
RoHS COMPLIANT	3. MSL 1
	FAIRCHILD SEMICONDUCTOR (F63TNR)8.0

Tape Leader and Trailer Configuration

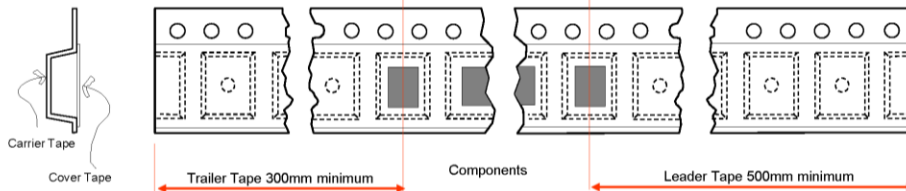

Figure 19. MicroPak™ 1.6 x 2.1 mm, Packing Drawing, Page 1

Package drawings are provided as a service to customers considering Fairchild components. Drawings may change in any manner without notice. Please note the revision and/or date on the drawing and contact a Fairchild Semiconductor representative to verify or obtain the most recent revision. Package specifications do not expand the terms of Fairchild's worldwide terms and conditions, specifically the warranty therein, which covers Fairchild products.

Always visit Fairchild Semiconductor's online packaging area for the most recent package drawings:

<http://www.fairchildsemi.com/packaging/>.

For current tape and reel specifications, visit Fairchild Semiconductor's online packaging area:

http://www.fairchildsemi.com/packaging_dwq/PKG-MAC10A-F131.pdf

Packing Specifications (Continued)

Embossed Tape Dimension

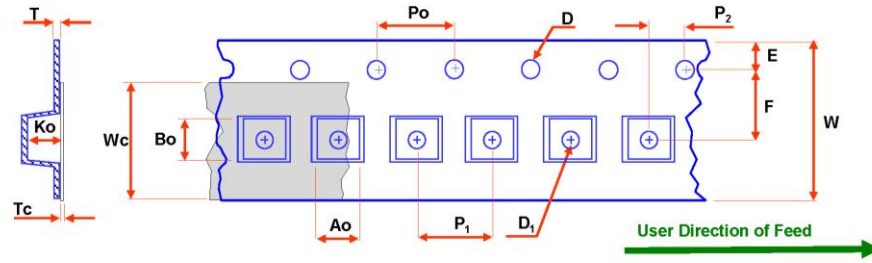

Dimensions are in millimeters

Package	Ao +/-0.05	Bo +/-0.05	D +/-0.10	D ₁ min.	E +/-0.1	F +/-0.1	Ko +/-0.05	P ₁ TYP	Po TYP	P ₂ +/-0/05	T TYP	Tc +/-0.005	W +/-0.3	Wc TYP
MAC10A	1.83	2.34	1.5	0.5	1.75	3.5	0.65	4	4	2.0	0.254	0.06	8	5.3

Notes: Ao, Bo, and Ko dimensions are determined with respect to the EIA /Jedec RS-481 rotational and lateral movement requirements (see sketches A, B, and C).

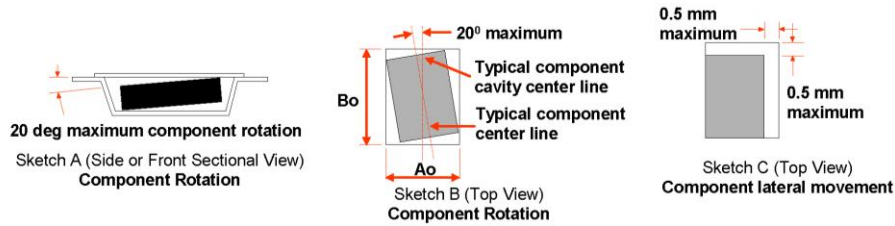

Shipping Reel Dimension

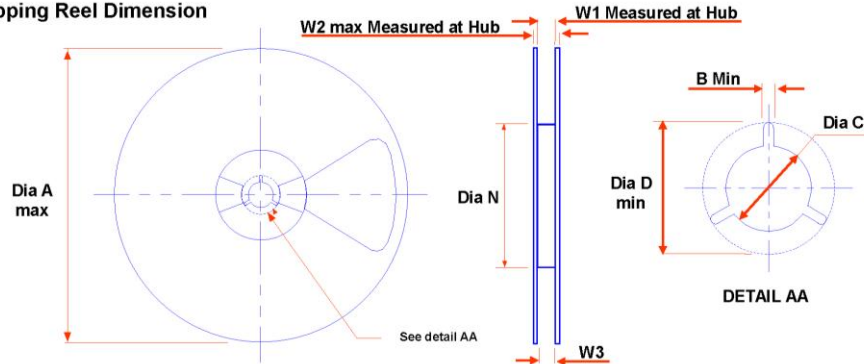

Dimensions are in millimeters

Tape Width	Dia A max	Dim B min	Dia C +5/-2	Dia D min	Dim N min	Dim W1 +2/-0	Dim W2 max	Dim W3 (LSL - USL)
8	178	1.5	13	20.2	55	8.4	14.4	7.9-10.4

APPROVALS	DATE		
DESIGN			MicroPak 1.6x2.1 F131 Packing Configuration
DATE CHG.			
ENGR. CHG.		SCALE: 1:1 SIZE: N/A PKG - MAC10A-F131 SHEET 1 of 1	

Figure 20. MicroPak™ 1.6 x 2.1 mm, Packing Drawing, Page 2

Package drawings are provided as a service to customers considering Fairchild components. Drawings may change in any manner without notice. Please note the revision and/or date on the drawing and contact a Fairchild Semiconductor representative to verify or obtain the most recent revision. Package specifications do not expand the terms of Fairchild's worldwide terms and conditions, specifically the warranty therein, which covers Fairchild products.





Always visit Fairchild Semiconductor's online packaging area for the most recent package drawings:
<http://www.fairchildsemi.com/packaging/>.

For current tape and reel specifications, visit Fairchild Semiconductor's online packaging area:
http://www.fairchildsemi.com/packing_dwq/PKG-MAC10A-F131.pdf



TRADEMARKS

The following includes registered and unregistered trademarks and service marks, owned by Fairchild Semiconductor and/or its global subsidiaries, and is not intended to be an exhaustive list of all such trademarks.

2Cool™	FPS™		Sync-Lock™
AccuPower™	F-PFS™	PowerTrench®	 SYSTEM GENERAL®
AX-CAP®*	FRFET®	PowerXS™	TinyBoost™
BitSiC™	Global Power Resource™	Programmable Active Droop™	TinyBuck™
Build it Now™	GreenBridge™	QFET®	TinyCalc™
CorePLUS™	Green FPS™	QS™	TinyLogic®
CorePOWER™	Green FPS™ e-Series™	Quiet Series™	TINYOPTO™
CROSSVOLT™	Gmax™	RapidConfigure™	TinyPower™
CTL™	GTO™		TinyPWM™
Current Transfer Logic™	IntelliMAX™	Saving our world, 1mW/W/kW at a time™	TinyWire™
DEUXPEED®	ISOPLANAR™	SignalWise™	TranSiC™
Dual Cool™	Making Small Speakers Sound Louder and Better™	SmartMax™	TriFault Detect™
EcoSPARK®	MegaBuck™	SMART START™	TRUECURRENT®*
EfficientMax™	MICROCOUPLER™	Solutions for Your Success™	μSerDes™
ESBC™	MicroFET™	SPM®	 SerDes®
	MicroPak™	STEALTH™	UHC®
Fairchild®	MicroPak2™	SuperFET®	Ultra FRFET™
Fairchild Semiconductor®	MillerDrive™	SuperSOT™-3	UniFET™
FACT Quiet Series™	MotionMax™	SuperSOT™-6	VCX™
FACT®	mWSaver™	SuperSOT™-8	VisualMax™
FAST®	OptoHi™	SupreMOS®	VoltagePlus™
FastvCore™	OPTOLOGIC®	SyncFET™	XS™
FETBench™	OPTOPLANAR®		

* Trademarks of System General Corporation, used under license by Fairchild Semiconductor.

DISCLAIMER

FAIRCHILD SEMICONDUCTOR RESERVES THE RIGHT TO MAKE CHANGES WITHOUT FURTHER NOTICE TO ANY PRODUCTS HEREIN TO IMPROVE RELIABILITY, FUNCTION, OR DESIGN. FAIRCHILD DOES NOT ASSUME ANY LIABILITY ARISING OUT OF THE APPLICATION OR USE OF ANY PRODUCT OR CIRCUIT DESCRIBED HEREIN; NEITHER DOES IT CONVEY ANY LICENSE UNDER ITS PATENT RIGHTS, NOR THE RIGHTS OF OTHERS. THESE SPECIFICATIONS DO NOT EXPAND THE TERMS OF FAIRCHILD'S WORLDWIDE TERMS AND CONDITIONS, SPECIFICALLY THE WARRANTY THEREIN, WHICH COVERS THESE PRODUCTS.

LIFE SUPPORT POLICY

FAIRCHILD'S PRODUCTS ARE NOT AUTHORIZED FOR USE AS CRITICAL COMPONENTS IN LIFE SUPPORT DEVICES OR SYSTEMS WITHOUT THE EXPRESS WRITTEN APPROVAL OF FAIRCHILD SEMICONDUCTOR CORPORATION.

As used herein:

- Life support devices or systems are devices or systems which, (a) are intended for surgical implant into the body or (b) support or sustain life, and (c) whose failure to perform when properly used in accordance with instructions for use provided in the labeling, can be reasonably expected to result in a significant injury of the user.
- A critical component in any component of a life support, device, or system whose failure to perform can be reasonably expected to cause the failure of the life support device or system, or to affect its safety or effectiveness.

ANTI-COUNTERFEITING POLICY

Fairchild Semiconductor Corporation's Anti-Counterfeiting Policy. Fairchild's Anti-Counterfeiting Policy is also stated on our external website, www.fairchildsemi.com, under Sales Support.

Counterfeiting of semiconductor parts is a growing problem in the industry. All manufacturers of semiconductor products are experiencing counterfeiting of their parts. Customers who inadvertently purchase counterfeit parts experience many problems such as loss of brand reputation, substandard performance, failed applications, and increased cost of production and manufacturing delays. Fairchild is taking strong measures to protect ourselves and our customers from the proliferation of counterfeit parts. Fairchild strongly encourages customers to purchase Fairchild parts either directly from Fairchild or from Authorized Fairchild Distributors who are listed by country on our web page cited above. Products customers buy either from Fairchild directly or from Authorized Fairchild Distributors are genuine parts, have full traceability, meet Fairchild's quality standards for handling and storage and provide access to Fairchild's full range of up-to-date technical and product information. Fairchild and our Authorized Distributors will stand behind all warranties and will appropriately address any warranty issues that may arise. Fairchild will not provide any warranty coverage or other assistance for parts bought from Unauthorized Sources. Fairchild is committed to combat this global problem and encourage our customers to do their part in stopping this practice by buying direct or from authorized distributors.

PRODUCT STATUS DEFINITIONS

Definition of Terms

Datasheet Identification	Product Status	Definition
Advance Information	Formative / In Design	Datasheet contains the design specifications for product development. Specifications may change in any manner without notice.
Preliminary	First Production	Datasheet contains preliminary data; supplementary data will be published at a later date. Fairchild Semiconductor reserves the right to make changes at any time without notice to improve design.
No Identification Needed	Full Production	Datasheet contains final specifications. Fairchild Semiconductor reserves the right to make changes at any time without notice to improve the design.
Obsolete	Not In Production	Datasheet contains specifications on a product that is discontinued by Fairchild Semiconductor. The datasheet is for reference information only.

Rev. 164

AMEYA360

Components Supply Platform

Authorized Distribution Brand :



Website :

Welcome to visit www.ameya360.com

Contact Us :

➤ Address :

401 Building No.5, JiuGe Business Center, Lane 2301, Yishan Rd
Minhang District, Shanghai , China

➤ Sales :

Direct +86 (21) 6401-6692

Email amall@ameya360.com

QQ 800077892

Skype [ameyasales1](#) [ameyasales2](#)

➤ Customer Service :

Email service@ameya360.com

➤ Partnership :

Tel +86 (21) 64016692-8333

Email mkt@ameya360.com