

## Single-Cell Protector for Li-Ion Batteries

 Check for Samples: [bq294602](#), [bq294604](#)

### FEATURES

- **Single-Cell Monitor for Secondary Protection**
- **Fixed Programmable Delay Timer**
- **Fixed OVP Threshold**
  - bq294602 = 4.35 V with 4-s Delay Timer
  - bq294604 = 4.35 V with 6.5-s Delay Timer
  - bq294622 = 4.45 V with 4-s Delay Timer
  - bq294624 = 4.45 V with 6.5-s Delay Timer
  - bq294682 = 4.225 V with 4-s Delay Timer
  - bq294684 = 4.225 V with 6.5-s Delay Timer
- **High-Accuracy Overvoltage Protection:**  
± 10 mV

- **Low Power Consumption**  $I_{CC} \approx 1 \mu A$   
( $V_{CELL(ALL)} < V_{PROTECT}$ )
- **Low leakage current per cell input** < 100 nA
- **Small package footprint**
  - 6-pin SON

### APPLICATIONS

- **2<sup>nd</sup>-Level Protection in Li-Ion Battery Packs in:**
  - Tablets
  - Slates
  - Portable Equipment and Instrumentation

### DESCRIPTION

The bq2946xy family of products is a secondary level voltage monitor and protector for Li-Ion battery pack systems. The cell is monitored for over voltage condition and triggers an internal counter once the OVP threshold is exceeded and after a fixed set delay the out is transitioned to a high level. The output is reset (goes low) if the cell voltage drops below the set threshold minus the hysteresis.

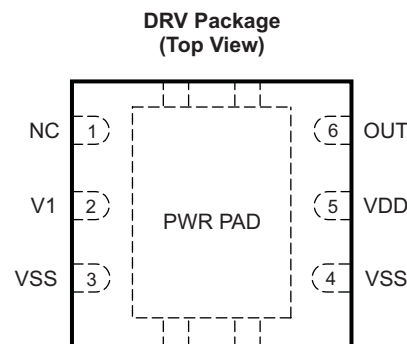

Please be aware that an important notice concerning availability, standard warranty, and use in critical applications of Texas Instruments semiconductor products and disclaimers thereto appears at the end of this data sheet.



These devices have limited built-in ESD protection. The leads should be shorted together or the device placed in conductive foam during storage or handling to prevent electrostatic damage to the MOS gates.

### ORDERING INFORMATION<sup>(1)</sup>

T <sub>A</sub>	PART NUMBER	PACKAGE	PACKAGE DESIGNATOR	OVP (V)	DELAY TIME (S)	TAPE AND REEL (LARGE)	TAPE AND REEL (SMALL)
-40°C to 110°C	bq294602	SON-6	DRV	4.35	4.0	bq294602DRVR	bq294602DRVT
	bq294604			4.35	6.5	bq294604DRVR	bq294604DRVT
	bq294622 <sup>(2)</sup>			4.45	4.0	bq294622DRVR	bq294622DRVT
	bq294624 <sup>(2)</sup>			4.45	6.5	bq294624DRVR	bq294624DRVT
	bq294682 <sup>(2)</sup>			4.225	4.0	bq294682DRVR	bq294682DRVT
	bq294684 <sup>(2)</sup>			4.225	6.5	bq294684DRVR	bq294684DRVT

(1) For the most current package and ordering information, see the Package Option Addendum at the end of this document, or visit the device product folder on ti.com ([www.ti.com](http://www.ti.com)).

(2) Product Preview only

### THERMAL INFORMATION

THERMAL METRIC <sup>(1)</sup>		bq2946xy	UNITS
		SON	
		6 PINS	
$\theta_{JA}$	Junction-to-ambient thermal resistance	186.4	°C/W
$\theta_{JC(top)}$	Junction-to-case(top) thermal resistance	90.4	
$\theta_{JB}$	Junction-to-board thermal resistance	110.7	
$\Psi_{JT}$	Junction-to-top characterization parameter	96.7	
$\Psi_{JB}$	Junction-to-board characterization parameter	90	
$\theta_{JC(bottom)}$	Junction-to-case(bottom) thermal resistance	n/a	

(1) For more information about traditional and new thermal metrics, see the *IC Package Thermal Metrics* application report, [SPRA953](#).

## PIN FUNCTIONS

bq2946xy	Pin Name	Type I/O	Description
1	NC	—	No Connection
2	V1	IA	Sense input for positive voltage of the cell
3	VSS	P	Electrically connected to IC ground and negative terminal of the cell
4	VSS	P	Electrically connected to IC ground and negative terminal of the cell
5	VDD	P	Power supply
6	OUT	OA	Output drive for external N-Channel FET
Thermal Pad	PWRPAD	—	VSS pin to be connected to the PWRPAD on the printed circuit board for proper operation

## PIN DETAILS

### Description

The method of overvoltage detection is comparing the cell voltage to an overvoltage protection threshold voltage  $V_{OV}$ . Once the cell voltage exceeds the programmed fixed value  $V_{OV}$ , the delay timer circuit is activated. This delay ( $t_{DELAY}$ ) is fixed for 4 s for the bq294602 device. When these conditions are satisfied, the OUT terminal is transitioned to a high level. This output (OUT) is released to a low condition if the cell input (V1) is below the OVP threshold minus the  $V_{HYS}$ .

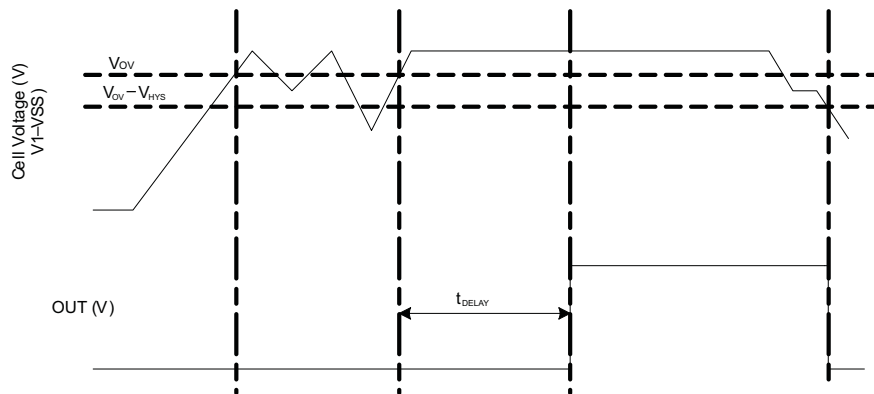

**Figure 1. Timing for Overvoltage Sensing**

### Sense Positive Input for V1

This is an input to sense single battery cell voltage. A series resistor and a capacitor across the cell is required for noise filtering and stable voltage monitoring.

### Output Drive, OUT

The gate of an external N-Channel MOSFET is connected to this terminal. This output transitions to a high level when an overvoltage condition is detected and after the programmed delay timer. The out will reset to a low level if the cell voltage falls below the  $V_{OV}$  threshold before the fixed delay timer expires.

### Supply Input, VDD

This terminal is the unregulated input power source for the IC. A series resistor is connected to limit the current, and a capacitor is connected to ground for noise filtering.

### Thermal Pad, PWRPAD

For correct operation, the power pad (PWRPAD) is connected to the  $V_{SS}$  terminal on the printed circuit board.

## FUNCTIONAL BLOCK DIAGRAM

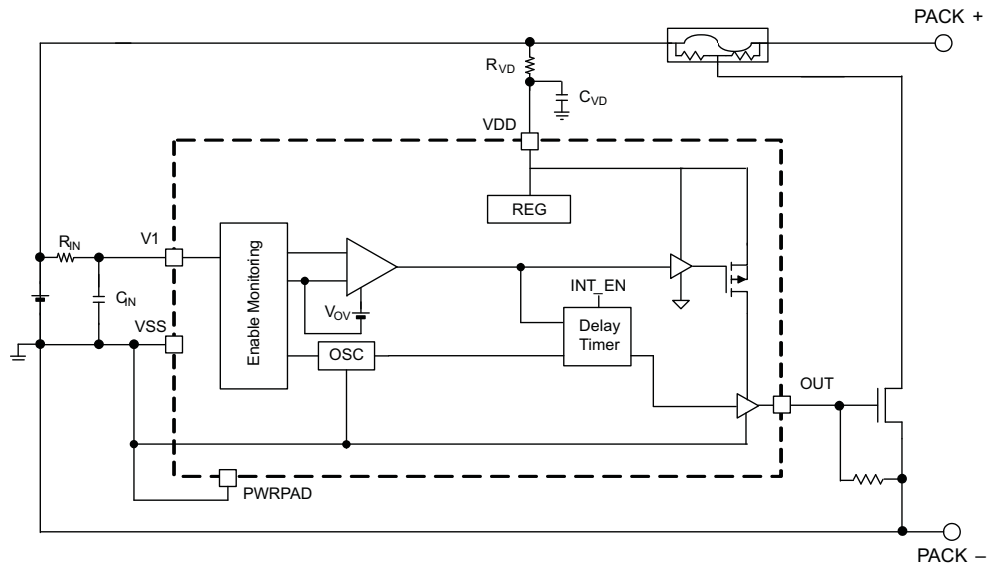

## ABSOLUTE MAXIMUM RATINGS

Over operating free-air temperature range (unless otherwise noted)<sup>(1)</sup>

PARAMETER	CONDITION	VALUE/UNIT
Supply voltage range	VDD–VSS	–0.3 to 30 V
Input voltage range	V1–VSS	–0.3 to 8 V
Output voltage range	OUT–VSS	–0.3 to 30 V
Continuous total power dissipation, P <sub>TOT</sub>		See package dissipation rating.
Functional temperature		–65 to 110°C
Storage temperature range, T <sub>STG</sub>		–65 to 150°C
Lead temperature (soldering, 10 s), T <sub>SOLDER</sub>		300°C

(1) Stresses beyond those listed under “absolute maximum ratings” may cause permanent damage to the device. These are stress ratings only and functional operation of the device at these or any other conditions beyond those indicated under “recommended operating conditions” is not implied. Exposure to absolute-maximum-rated conditions for extended periods may affect device reliability.

## RECOMMENDED OPERATING CONDITIONS

Over operating free-air temperature range (unless otherwise noted)

PARAMETER	MIN	NOM	MAX	UNIT
Supply voltage, V <sub>DD</sub> <sup>(1)</sup>	3		8	V
Input voltage range   V1–VSS	0		5	V
Operating ambient temperature range, T <sub>A</sub>	–40		110	°C

(1) See [APPLICATION SCHEMATIC](#).

## DC CHARACTERISTICS

Typical values stated where  $T_A = 25^\circ\text{C}$  and  $V_{DD} = 4\text{ V}$ , MIN/MAX values stated where  $T_A = -40^\circ\text{C}$  to  $110^\circ\text{C}$  and  $V_{DD} = 4\text{ V}$  (unless otherwise noted).

Test #	Symbol	Parameter	Condition	Min	Typ	Max	Unit
<b>Voltage Protection Threshold VCx</b>							
1.0	$V_{OV}$	V <sup>(PROTECT)</sup> – Overvoltage Detection	bq294602, fixed delay 4 s, $V_1 > V_{OV}$		4.35		V
1.1			bq294604, fixed delay 6.5 s, $V_1 > V_{OV}$		4.35		V
1.2			bq294622, fixed delay 4 s, $V_1 > V_{OV}$ <sup>(1)</sup>		4.45		V
1.3			bq294624, fixed delay 6.5 s, $V_1 > V_{OV}$ <sup>(1)</sup>		4.45		V
1.4			bq294682, fixed delay 4 s, $V_1 > V_{OV}$ <sup>(1)</sup>		4.225		V
1.5			bq294684, fixed delay 6.5 s, $V_1 > V_{OV}$ <sup>(1)</sup>		4.225		V
1.6	$V_{HYS}$	Overvoltage Detection Hysteresis		250	300	400	V
1.7	$V_{OA}$	OV Detection Accuracy	$T_A = 25^\circ\text{C}$	-10		10	mV
1.8	$V_{OA-DRIFT}$	OV Detection Accuracy due to Temperature	$T_A = -40^\circ\text{C}$ $T_A = 0^\circ\text{C}$ $T_A = 60^\circ\text{C}$ $T_A = 110^\circ\text{C}$	-40 -20 -24 -54		44 20 24 54	mV mV mV mV
<b>Supply and Leakage Current</b>							
1.9	$I_{CC}$	Supply Current	$(V_1 - V_{SS}) = 4.0\text{ V}$ (See <a href="#">Figure 9</a> for reference) $(V_1 - V_{SS}) = 2.8\text{ V}$ with $T_A = -40^\circ\text{C}$ to $60^\circ\text{C}$		1	2	$\mu\text{A}$
						1.25	
1.10	$I_{IN}$	Input Current at V1 Pins	Measured at $V_1 = 4.0\text{ V}$ $(V_1 - V_{SS}) = 4.0\text{ V}$ $T_A = 0^\circ\text{C}$ to $60^\circ\text{C}$ (See <a href="#">Figure 9</a> for reference.)	-0.1		0.1	$\mu\text{A}$
<b>Output Drive OUT</b>							
1.11	$V_{OUT}$	Output Drive Voltage	$(V_1 - V_{SS}) > V_{OV}$ $V_{DD} = V_1$ , $I_{OH} = 100\ \mu\text{A}$ , $T_A = -40^\circ\text{C}$ to $110^\circ\text{C}$	3.0	$V_{DD} - 0.3$		V
1.12			$(V_1 - V_{SS}) < V_{OV}$ , $I_{OL} = 100\ \mu\text{A}$ , $T_A = 25^\circ\text{C}$ $T_A = -40^\circ\text{C}$ to $110^\circ\text{C}$		250	400	mV
1.13							
1.14	$I_{OUT(Short)}$	OUT Short Circuit Current	OUT = 0 V, $(V_1 - V_{SS}) > V_{OV}$		1.5	3.0	mA
1.15	$t_R$	Output Rise Time	CL = 1 nF, $V_{OH(OUT)} = 0\text{ V}$ to $5\text{ V}$ <sup>(2)</sup>		5		$\mu\text{s}$
1.16	$Z_O$	Output Impedance			2	5	k $\Omega$
<b>Fixed Delay Timer</b>							
1.17	$t_{DELAY}$	Fault Detection Delay Time	Fixed Delay, bq2946x2 Fixed Delay, bq2946x4	3.2 5.2	4 6.5	4.8 7.8	s
1.18	$t_{DELAY\_CTM}$	Fault Detection Delay Time in Test Mode	Fixed delay (Internal settings)		15		ms

(1) Product Preview only

(2) Specified by design. Not 100% tested in production.

**TYPICAL CHARACTERISTICS**

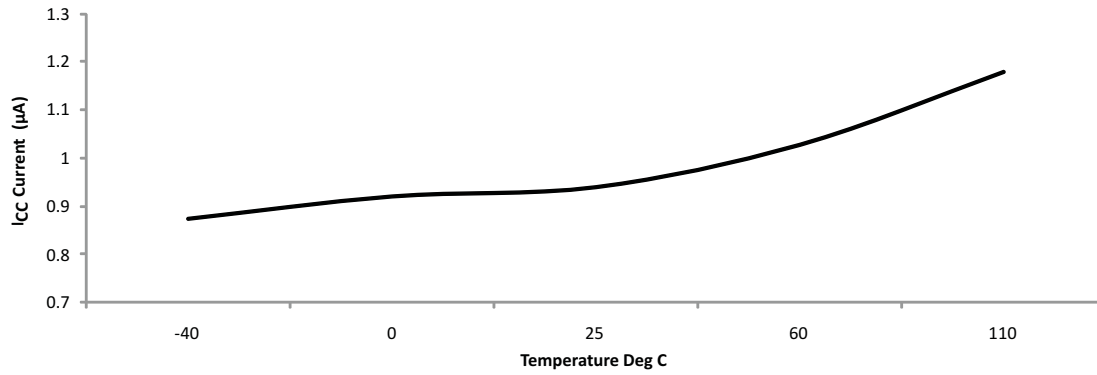

**Figure 2. I<sub>CC</sub> Current Consumption Versus Temperature**

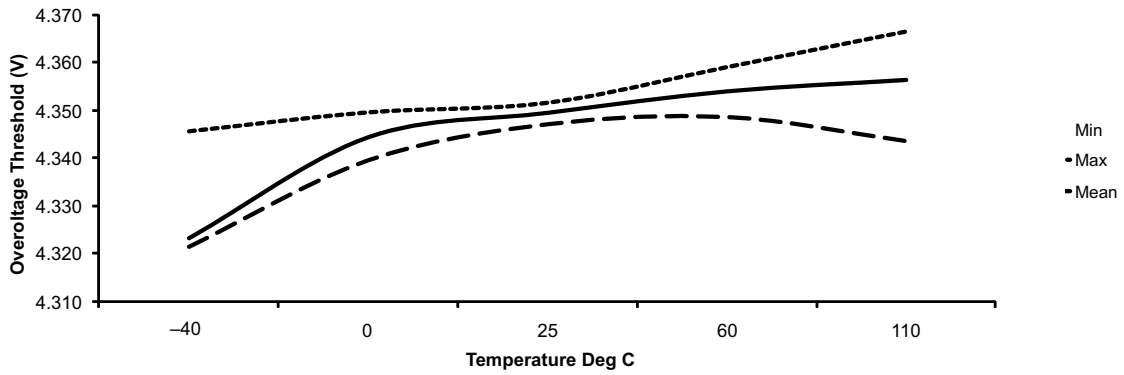

**Figure 3. bq294602 Overvoltage Threshold (OVT) vs. Temp**

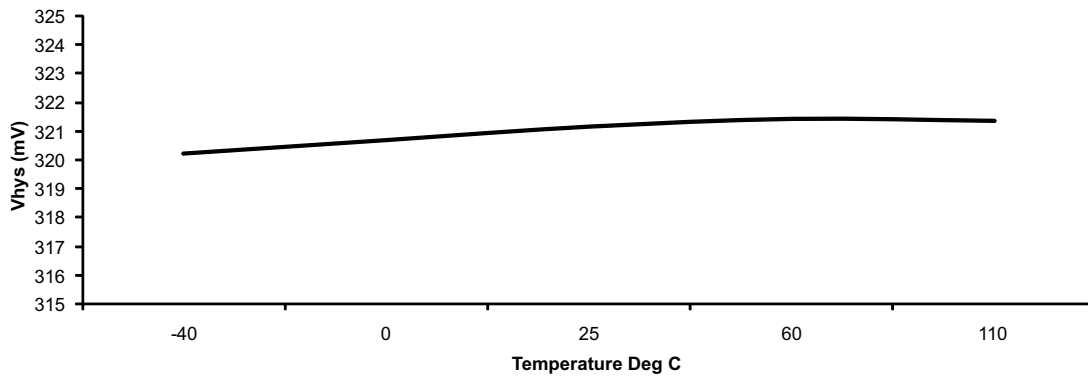

**Figure 4. Hysteresis V<sub>HYS</sub> Versus Temperature**

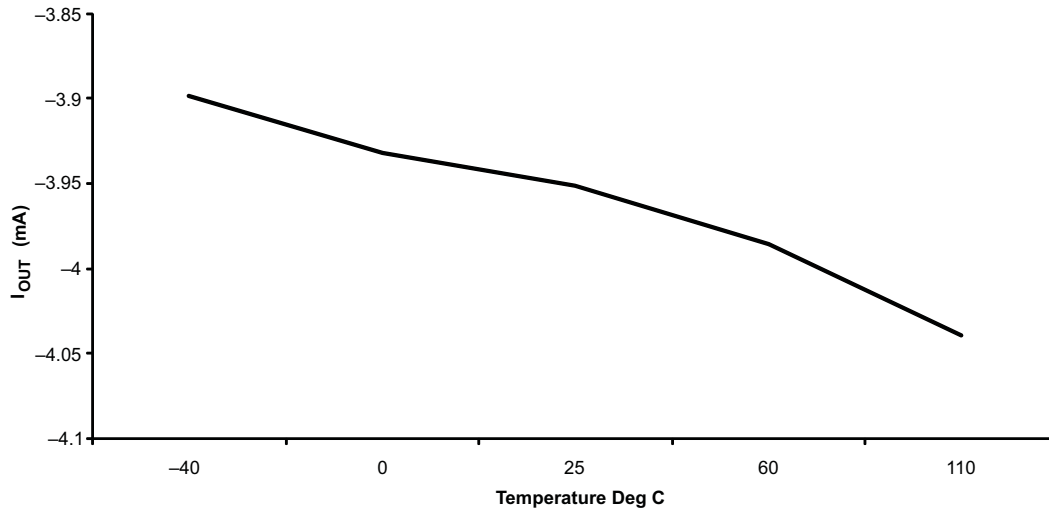

Figure 5. Output Current  $I_{OUT}$  Versus Temperature

### APPLICATION INFORMATION

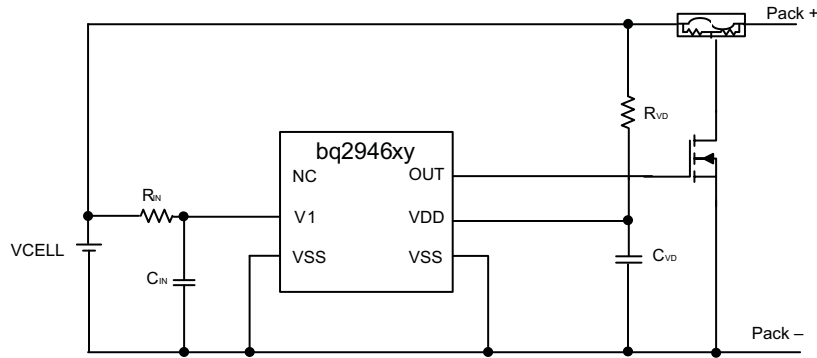

Figure 6. Application Configuration

**NOTE**

Connect VSS (Pins 3 and 4) externally to the CELL– terminal.

Changes to the ranges stated in Table 1 will impact the accuracy of the cell measurements. Figure 6 shows each external component.

Table 1. Parameters

PARAMETER	External Component	MIN	NOM	MAX	UNIT
Voltage monitor filter resistance	RIN	900	1000	1100	Ω
Voltage monitor filter capacitance	CIN	0.01	0.1		μF
Supply voltage filter resistance	RVD	100		1K	Ω
Supply voltage filter capacitance	CVD		0.1		μF

### APPLICATION SCHEMATIC

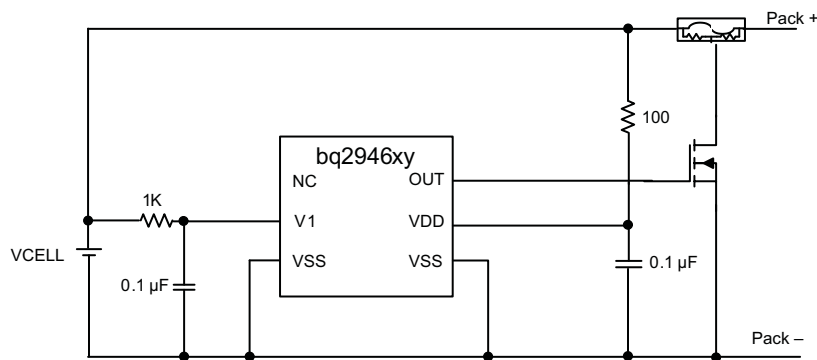

Figure 7. 1-Cell Configuration with Fixed Delay

**NOTE**

Connect VSS (Pins 3 and 4) externally to the CELL– terminal.

## CUSTOMER TEST MODE

Customer Test Mode (CTM) helps to reduce test time for checking the overvoltage delay timer parameter once the circuit is implemented in the battery pack. To enter CTM, VDD should be set to at least 10 V higher than V1 (see Figure 8). The delay timer is greater than 10 ms, but considerably shorter than the timer delay in normal operation. To exit Customer Test Mode, remove the VDD to V1 voltage differential of 10 V so that the decrease in this value automatically causes an exit.

**CAUTION**

Avoid exceeding any Absolute Maximum Voltages on any pins when placing the part into Customer Test Mode. Also avoid exceeding Absolute Maximum Voltage for the cell voltage (V1–VSS). Stressing the pins beyond the rated limits may cause permanent damage to the device.

Figure 8 shows the timing for the Customer Test Mode.

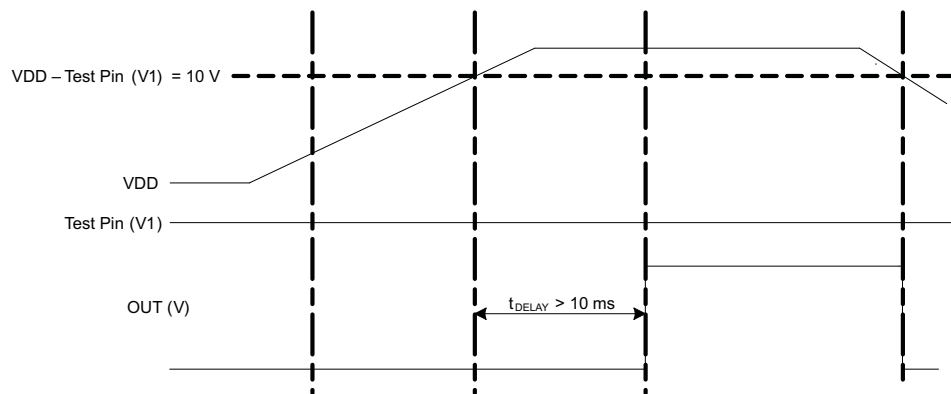

Figure 8. Timing for Customer Test Mode

Figure 9 shows the measurement for current consumption for the product for both VDD and Vx.

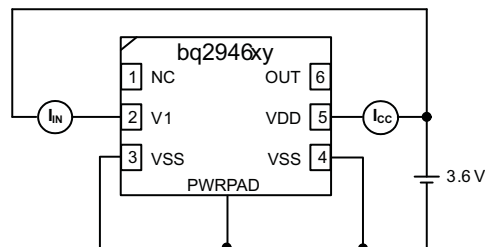

Figure 9. Configuration for IC Current Consumption Test

## REVISION HISTORY

---

<b>Changes from Original (December 2011) to Revision A</b>	<b>Page</b>
--	-------------

---

- Added the bq294604 device into production. .... [2](#)
- 

<b>Changes from Original (February 2012) to Revision B</b>	<b>Page</b>
--	-------------

---

- Added a second  $I_{CC}$  Test Condition ..... [5](#)
-

## PACKAGING INFORMATION

Orderable Device	Status (1)	Package Type	Package Drawing	Pins	Package Qty	Eco Plan (2)	Lead/Ball Finish	MSL Peak Temp (3)	Op Temp (°C)	Top-Side Markings (4)	Samples
BQ294602DRVR	PREVIEW	SON	DRV	6		Green (RoHS & no Sb/Br)	CU NIPDAU	Level-2-260C-1 YEAR	-40 to 85	4602	
BQ294602DRVT	PREVIEW	SON	DRV	6		Green (RoHS & no Sb/Br)	CU NIPDAU	Level-2-260C-1 YEAR	-40 to 85	4602	
BQ294604DRVR	ACTIVE	SON	DRV	6	3000	Green (RoHS & no Sb/Br)	CU NIPDAU	Level-2-260C-1 YEAR	-40 to 85	4604	<a href="#">Samples</a>
BQ294604DRVT	ACTIVE	SON	DRV	6	250	Green (RoHS & no Sb/Br)	CU NIPDAU	Level-2-260C-1 YEAR	-40 to 85	4604	<a href="#">Samples</a>

(1) The marketing status values are defined as follows:

**ACTIVE:** Product device recommended for new designs.

**LIFEBUY:** TI has announced that the device will be discontinued, and a lifetime-buy period is in effect.

**NRND:** Not recommended for new designs. Device is in production to support existing customers, but TI does not recommend using this part in a new design.

**PREVIEW:** Device has been announced but is not in production. Samples may or may not be available.

**OBSOLETE:** TI has discontinued the production of the device.

(2) Eco Plan - The planned eco-friendly classification: Pb-Free (RoHS), Pb-Free (RoHS Exempt), or Green (RoHS & no Sb/Br) - please check <http://www.ti.com/productcontent> for the latest availability information and additional product content details.

**TBD:** The Pb-Free/Green conversion plan has not been defined.

**Pb-Free (RoHS):** TI's terms "Lead-Free" or "Pb-Free" mean semiconductor products that are compatible with the current RoHS requirements for all 6 substances, including the requirement that lead not exceed 0.1% by weight in homogeneous materials. Where designed to be soldered at high temperatures, TI Pb-Free products are suitable for use in specified lead-free processes.

**Pb-Free (RoHS Exempt):** This component has a RoHS exemption for either 1) lead-based flip-chip solder bumps used between the die and package, or 2) lead-based die adhesive used between the die and leadframe. The component is otherwise considered Pb-Free (RoHS compatible) as defined above.

**Green (RoHS & no Sb/Br):** TI defines "Green" to mean Pb-Free (RoHS compatible), and free of Bromine (Br) and Antimony (Sb) based flame retardants (Br or Sb do not exceed 0.1% by weight in homogeneous material)

(3) MSL, Peak Temp. -- The Moisture Sensitivity Level rating according to the JEDEC industry standard classifications, and peak solder temperature.

(4) Only one of markings shown within the brackets will appear on the physical device.

**Important Information and Disclaimer:** The information provided on this page represents TI's knowledge and belief as of the date that it is provided. TI bases its knowledge and belief on information provided by third parties, and makes no representation or warranty as to the accuracy of such information. Efforts are underway to better integrate information from third parties. TI has taken and continues to take reasonable steps to provide representative and accurate information but may not have conducted destructive testing or chemical analysis on incoming materials and chemicals. TI and TI suppliers consider certain information to be proprietary, and thus CAS numbers and other limited information may not be available for release.

In no event shall TI's liability arising out of such information exceed the total purchase price of the TI part(s) at issue in this document sold by TI to Customer on an annual basis.



## TAPE AND REEL INFORMATION



### QUADRANT ASSIGNMENTS FOR PIN 1 ORIENTATION IN TAPE



\*All dimensions are nominal

Device	Package Type	Package Drawing	Pins	SPQ	Reel Diameter (mm)	Reel Width W1 (mm)	A0 (mm)	B0 (mm)	K0 (mm)	P1 (mm)	W (mm)	Pin1 Quadrant
BQ294602DRVR	SON	DRV	6	0	330.0	12.4	2.2	2.2	1.1	8.0	12.0	Q2
BQ294602DRVT	SON	DRV	6	0	180.0	12.4	2.2	2.2	1.1	8.0	12.0	Q2
BQ294604DRVR	SON	DRV	6	3000	330.0	12.4	2.2	2.2	1.1	8.0	12.0	Q2
BQ294604DRVT	SON	DRV	6	250	180.0	12.4	2.2	2.2	1.1	8.0	12.0	Q2

**TAPE AND REEL BOX DIMENSIONS**

\*All dimensions are nominal

Device	Package Type	Package Drawing	Pins	SPQ	Length (mm)	Width (mm)	Height (mm)
BQ294602DRVR	SON	DRV	6	0	367.0	367.0	35.0
BQ294602DRVT	SON	DRV	6	0	210.0	185.0	35.0
BQ294604DRVR	SON	DRV	6	3000	367.0	367.0	35.0
BQ294604DRVT	SON	DRV	6	250	210.0	185.0	35.0

DRV (S-PWSON-N6)

PLASTIC SMALL OUTLINE NO-LEAD

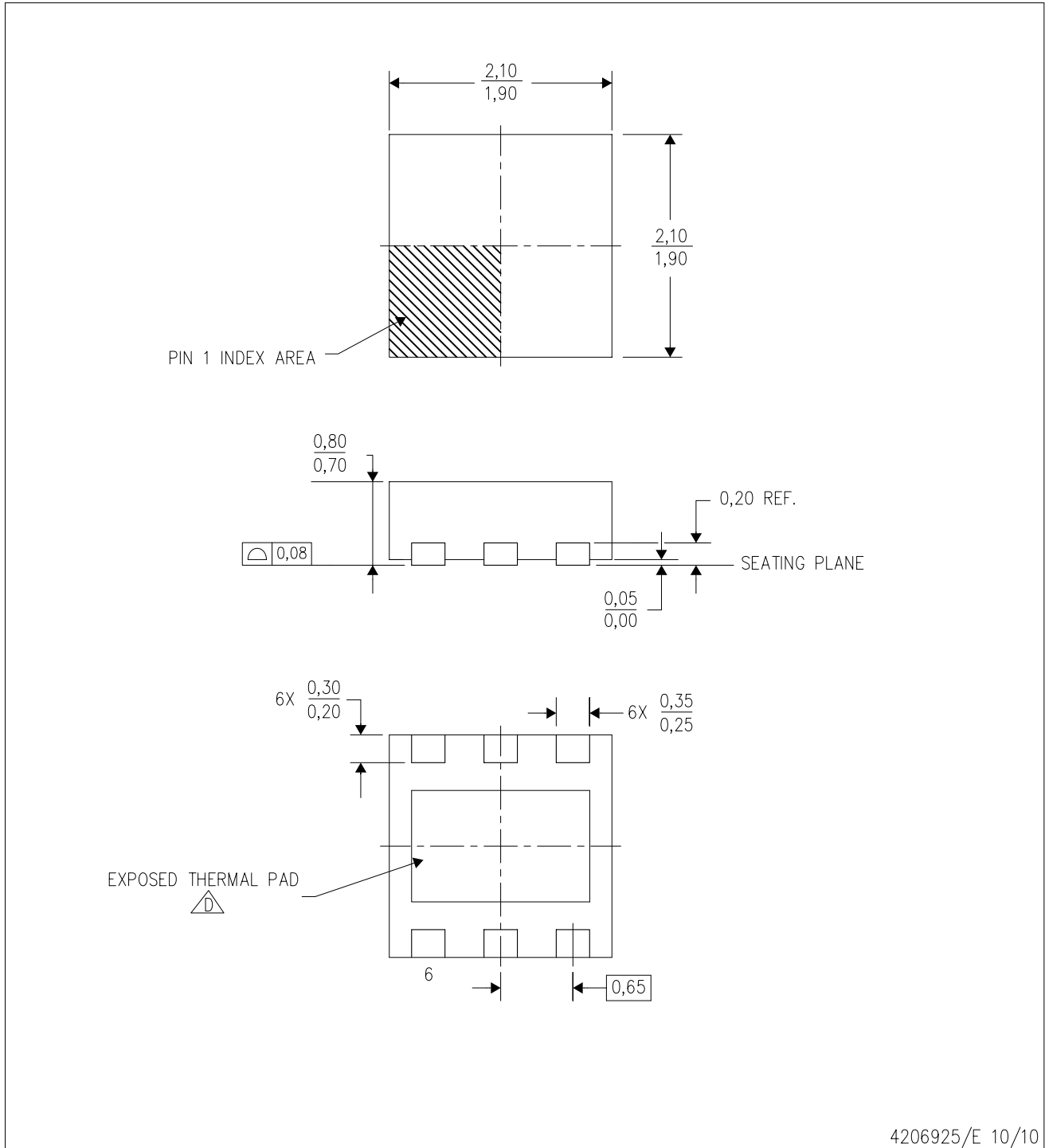

4206925/E 10/10

- NOTES:
- A. All linear dimensions are in millimeters. Dimensioning and tolerancing per ASME Y14.5M-1994.
  - B. This drawing is subject to change without notice.
  - C. Small Outline No-Lead (SON) package configuration.
  - $\triangle D$  The package thermal pad must be soldered to the board for thermal and mechanical performance. See the Product Data Sheet for details regarding the exposed thermal pad dimensions.

## THERMAL PAD MECHANICAL DATA

DRV (S-PWSON-N6)

PLASTIC SMALL OUTLINE NO-LEAD

### THERMAL INFORMATION

This package incorporates an exposed thermal pad that is designed to be attached directly to an external heatsink. The thermal pad must be soldered directly to the printed circuit board (PCB). After soldering, the PCB can be used as a heatsink. In addition, through the use of thermal vias, the thermal pad can be attached directly to the appropriate copper plane shown in the electrical schematic for the device, or alternatively, can be attached to a special heatsink structure designed into the PCB. This design optimizes the heat transfer from the integrated circuit (IC).

For information on the Quad Flatpack No-Lead (QFN) package and its advantages, refer to Application Report, QFN/SON PCB Attachment, Texas Instruments Literature No. SLUA271. This document is available at [www.ti.com](http://www.ti.com).

The exposed thermal pad dimensions for this package are shown in the following illustration.

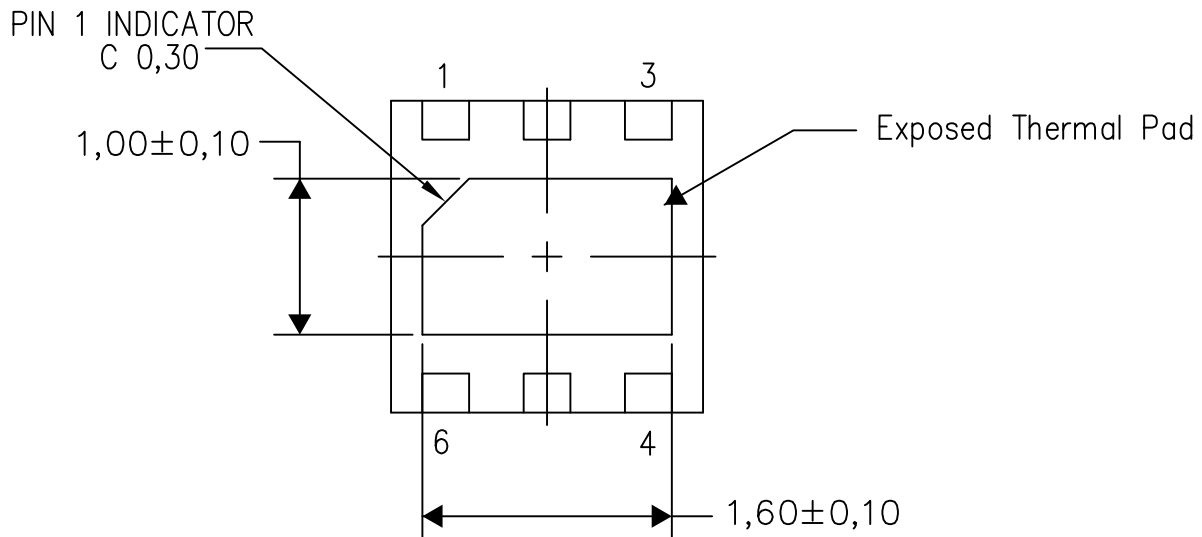

Bottom View

Exposed Thermal Pad Dimensions

4206926/N 03/13

NOTE: All linear dimensions are in millimeters

DRV (S-PWSON-N6)

PLASTIC SMALL OUTLINE NO-LEAD

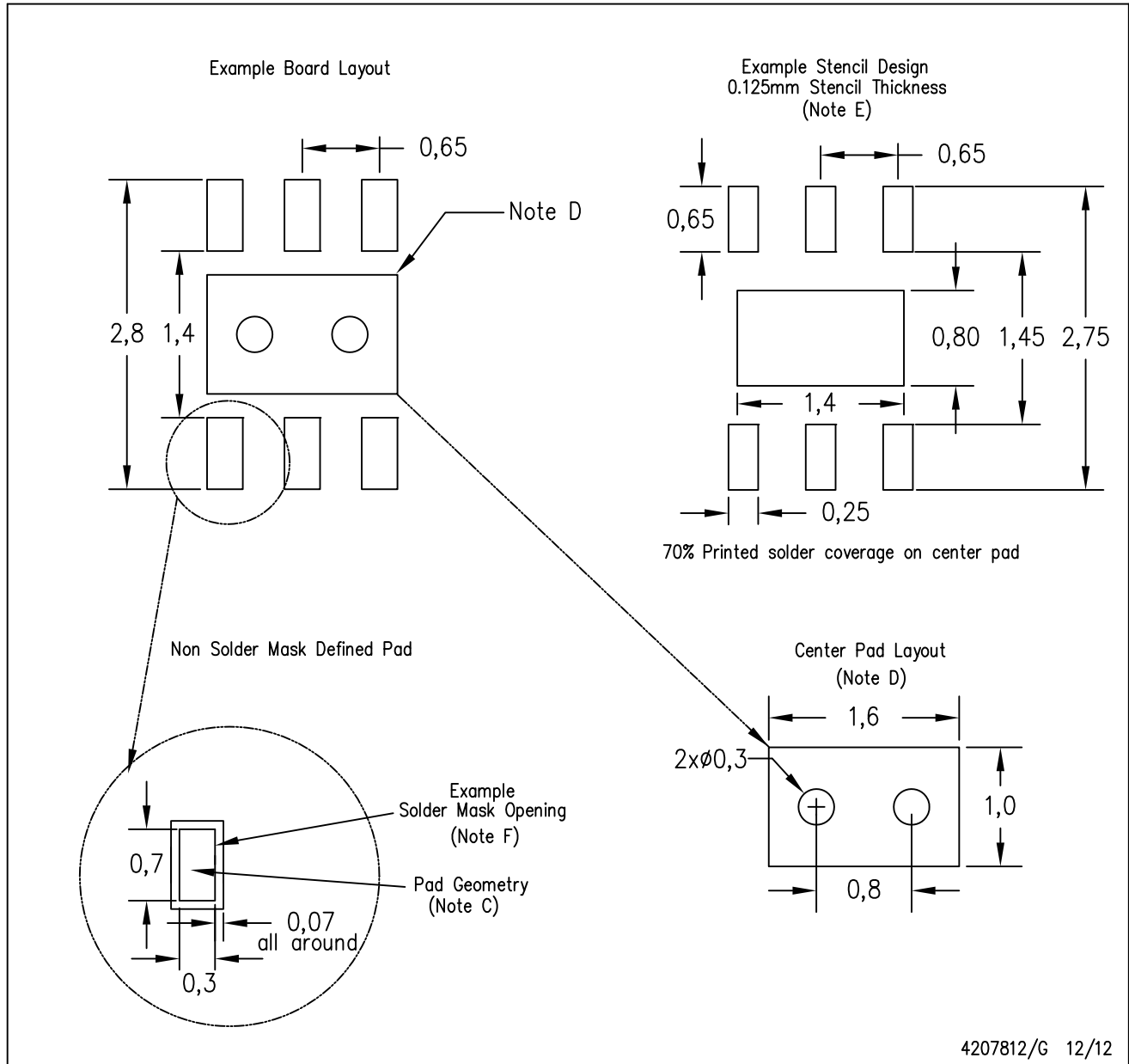

- NOTES:
- All linear dimensions are in millimeters.
  - This drawing is subject to change without notice.
  - Publication IPC-7351 is recommended for alternate designs.
  - This package is designed to be soldered to a thermal pad on the board. Refer to Application Note, QFN/SON PCB Attachment, Texas Instruments Literature No. SLUA271, and also the Product Data Sheets for specific thermal information, via requirements, and recommended board layout. These documents are available at [www.ti.com](http://www.ti.com) <<http://www.ti.com>>.
  - Laser cutting apertures with trapezoidal walls and also rounding corners will offer better paste release. Customers should contact their board assembly site for stencil design recommendations. Refer to IPC 7525 for stencil design considerations.
  - Customers should contact their board fabrication site for solder mask tolerances.

## IMPORTANT NOTICE

Texas Instruments Incorporated and its subsidiaries (TI) reserve the right to make corrections, enhancements, improvements and other changes to its semiconductor products and services per JESD46, latest issue, and to discontinue any product or service per JESD48, latest issue. Buyers should obtain the latest relevant information before placing orders and should verify that such information is current and complete. All semiconductor products (also referred to herein as "components") are sold subject to TI's terms and conditions of sale supplied at the time of order acknowledgment.

TI warrants performance of its components to the specifications applicable at the time of sale, in accordance with the warranty in TI's terms and conditions of sale of semiconductor products. Testing and other quality control techniques are used to the extent TI deems necessary to support this warranty. Except where mandated by applicable law, testing of all parameters of each component is not necessarily performed.

TI assumes no liability for applications assistance or the design of Buyers' products. Buyers are responsible for their products and applications using TI components. To minimize the risks associated with Buyers' products and applications, Buyers should provide adequate design and operating safeguards.

TI does not warrant or represent that any license, either express or implied, is granted under any patent right, copyright, mask work right, or other intellectual property right relating to any combination, machine, or process in which TI components or services are used. Information published by TI regarding third-party products or services does not constitute a license to use such products or services or a warranty or endorsement thereof. Use of such information may require a license from a third party under the patents or other intellectual property of the third party, or a license from TI under the patents or other intellectual property of TI.

Reproduction of significant portions of TI information in TI data books or data sheets is permissible only if reproduction is without alteration and is accompanied by all associated warranties, conditions, limitations, and notices. TI is not responsible or liable for such altered documentation. Information of third parties may be subject to additional restrictions.

Resale of TI components or services with statements different from or beyond the parameters stated by TI for that component or service voids all express and any implied warranties for the associated TI component or service and is an unfair and deceptive business practice. TI is not responsible or liable for any such statements.

Buyer acknowledges and agrees that it is solely responsible for compliance with all legal, regulatory and safety-related requirements concerning its products, and any use of TI components in its applications, notwithstanding any applications-related information or support that may be provided by TI. Buyer represents and agrees that it has all the necessary expertise to create and implement safeguards which anticipate dangerous consequences of failures, monitor failures and their consequences, lessen the likelihood of failures that might cause harm and take appropriate remedial actions. Buyer will fully indemnify TI and its representatives against any damages arising out of the use of any TI components in safety-critical applications.

In some cases, TI components may be promoted specifically to facilitate safety-related applications. With such components, TI's goal is to help enable customers to design and create their own end-product solutions that meet applicable functional safety standards and requirements. Nonetheless, such components are subject to these terms.

No TI components are authorized for use in FDA Class III (or similar life-critical medical equipment) unless authorized officers of the parties have executed a special agreement specifically governing such use.

Only those TI components which TI has specifically designated as military grade or "enhanced plastic" are designed and intended for use in military/aerospace applications or environments. Buyer acknowledges and agrees that any military or aerospace use of TI components which have **not** been so designated is solely at the Buyer's risk, and that Buyer is solely responsible for compliance with all legal and regulatory requirements in connection with such use.

TI has specifically designated certain components as meeting ISO/TS16949 requirements, mainly for automotive use. In any case of use of non-designated products, TI will not be responsible for any failure to meet ISO/TS16949.

### Products

Audio	<a href="http://www.ti.com/audio">www.ti.com/audio</a>
Amplifiers	<a href="http://amplifier.ti.com">amplifier.ti.com</a>
Data Converters	<a href="http://dataconverter.ti.com">dataconverter.ti.com</a>
DLP® Products	<a href="http://www.dlp.com">www.dlp.com</a>
DSP	<a href="http://dsp.ti.com">dsp.ti.com</a>
Clocks and Timers	<a href="http://www.ti.com/clocks">www.ti.com/clocks</a>
Interface	<a href="http://interface.ti.com">interface.ti.com</a>
Logic	<a href="http://logic.ti.com">logic.ti.com</a>
Power Mgmt	<a href="http://power.ti.com">power.ti.com</a>
Microcontrollers	<a href="http://microcontroller.ti.com">microcontroller.ti.com</a>
RFID	<a href="http://www.ti-rfid.com">www.ti-rfid.com</a>
OMAP Applications Processors	<a href="http://www.ti.com/omap">www.ti.com/omap</a>
Wireless Connectivity	<a href="http://www.ti.com/wirelessconnectivity">www.ti.com/wirelessconnectivity</a>

### Applications

Automotive and Transportation	<a href="http://www.ti.com/automotive">www.ti.com/automotive</a>
Communications and Telecom	<a href="http://www.ti.com/communications">www.ti.com/communications</a>
Computers and Peripherals	<a href="http://www.ti.com/computers">www.ti.com/computers</a>
Consumer Electronics	<a href="http://www.ti.com/consumer-apps">www.ti.com/consumer-apps</a>
Energy and Lighting	<a href="http://www.ti.com/energy">www.ti.com/energy</a>
Industrial	<a href="http://www.ti.com/industrial">www.ti.com/industrial</a>
Medical	<a href="http://www.ti.com/medical">www.ti.com/medical</a>
Security	<a href="http://www.ti.com/security">www.ti.com/security</a>
Space, Avionics and Defense	<a href="http://www.ti.com/space-avionics-defense">www.ti.com/space-avionics-defense</a>
Video and Imaging	<a href="http://www.ti.com/video">www.ti.com/video</a>

### TI E2E Community

[e2e.ti.com](http://e2e.ti.com)

# AMEYA360

## Components Supply Platform

Authorized Distribution Brand :



Website :

Welcome to visit [www.ameya360.com](http://www.ameya360.com)

Contact Us :

➤ Address :

401 Building No.5, JiuGe Business Center, Lane 2301, Yishan Rd  
Minhang District, Shanghai , China

➤ Sales :

Direct +86 (21) 6401-6692

Email [amall@ameya360.com](mailto:amall@ameya360.com)

QQ 800077892

Skype [ameyasales1](#) [ameyasales2](#)

➤ Customer Service :

Email [service@ameya360.com](mailto:service@ameya360.com)

➤ Partnership :

Tel +86 (21) 64016692-8333

Email [mkt@ameya360.com](mailto:mkt@ameya360.com)