

LM101A/LM201A/LM301A Operational Amplifiers

 Check for Samples: [LM101A-N](#), [LM201A-N](#), [LM301A-N](#)

FEATURES

- Improved Specifications include:
- Offset Voltage 3 mV Maximum Over Temperature (LM101A/LM201A)
- Input Current 100 nA Maximum Over Temperature (LM101A/LM201A)
- Offset Current 20 nA Maximum Over Temperature (LM101A/LM201A)
- Specified Drift Characteristics
- Offsets Specified Over Entire Common Mode and Supply Voltage Ranges
- Slew Rate of 10V/μs as a Summing Amplifier

DESCRIPTION

The LM101A series are general purpose operational amplifiers which feature improved performance over industry standards like the LM709. Advanced processing techniques make possible an order of magnitude reduction in input currents, and a redesign of the biasing circuitry reduces the temperature drift of input current.

This amplifier offers many features which make its application nearly foolproof: Overload protection on the input and output, no latch-up when the common mode range is exceeded, and freedom from oscillations and compensation with a single 30 pF Capacitor. It has advantages over internally compensated amplifiers in that the frequency compensation can be tailored to the particular application. For example, in low frequency circuits it can be overcompensated for increased stability margin or the compensation can be optimized to give more than a factor of ten improvement in high frequency performance for most applications.

In Addition, the device provides better accuracy and lower noise in high impedance circuitry. The low input currents also make it particularly well suited for long interval integrators or timers, sample and hold circuits and low frequency waveform generators. Further, replacing circuits where matched transistor pairs buffer the inputs of conventional IC op amps, It can give lower offset voltage and a drift at a lower cost.

The LM101A is ensured over a temperature range of -55°C to +125°C, the LM201A from -25°C to +85°C, and the LM301A from 0°C to +70°C.

Fast AC-DC Converter

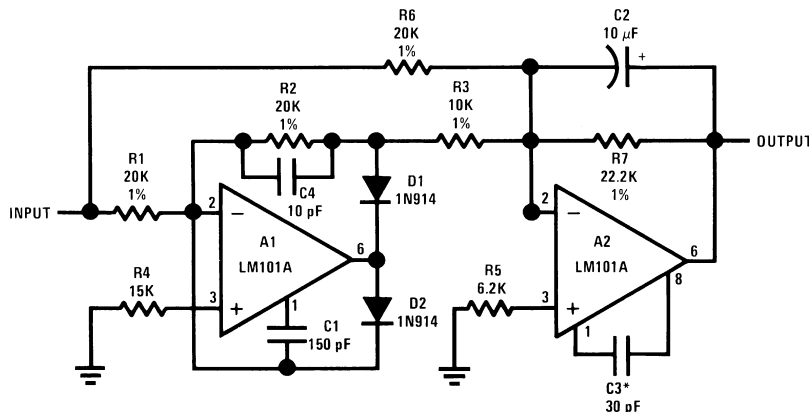

Feedforward compensation can be used to make a fast full wave rectifier without a filter.



Please be aware that an important notice concerning availability, standard warranty, and use in critical applications of Texas Instruments semiconductor products and disclaimers thereto appears at the end of this data sheet.



These devices have limited built-in ESD protection. The leads should be shorted together or the device placed in conductive foam during storage or handling to prevent electrostatic damage to the MOS gates.

Absolute Maximum Ratings⁽¹⁾⁽²⁾

	LM101A/LM201A	LM301A
Supply Voltage	±22V	±18V
Differential Input Voltage	±30V	±30V
Input Voltage ⁽³⁾	±15V	±15V
Output Short Circuit Duration ⁽⁴⁾	Continuous	Continuous
Operating Ambient Temp. Range	-55°C to +125°C (LM101A)	0°C to +70°C
	-25°C to +85°C (LM201A)	
T _J Max		
LMC0008C Package	150°C	100°C
P0008E Package	150°C	100°C
NAB0008A, J0014A Package	150°C	100°C
Power Dissipation at T _A = 25°C		
LMC0008C-Package (Still Air) (400 LF/Min Air Flow)	500 mW	300 mW
	1200 mW	700 mW
P0008E Package	900 mW	500 mW
NAB0008A, J0014A Package	1000 mW	650 mW
Thermal Resistance (Typical) θ _{JA}		
LMC0008C Package (Still Air) (400 LF/Min Air Flow)	165°C/W	165°C/W
	67°C/W	67°C/W
P0008E Package	135°C/W	135°C/W
NAB0008A, J0014A Package	110°C/W	110°CmW
(Typical) θ _{JC}		
LMC0008C Package	25°C/W	25°C/W
Storage Temperature Range	-65°C to +150°C	-65°C to +150°C
Lead Temperature (Soldering, 10 sec.)		
LMC0008C or NAB0008A, J0014A, NAD0010A	300°C	300°C
P0008E	260°C	260°C
ESD Tolerance ⁽⁵⁾	2000V	2000V

- (1) Absolute Maximum Ratings indicate limits beyond which damage to the device may occur. Operating ratings indicate for which the device is functional, but do not ensure specific performance limits. Electrical Characteristics state DC and AC electrical specifications under particular test conditions which ensure specific limits. This assumes that the device is within the Operating Ratings. Specifications are not ensured for parameters where no limit is given, however, the typical value is a good indication of device performance.
- (2) If Military/Aerospace specified devices are required, please contact the Texas Instruments Sales Office/Distributors for availability and specifications.
- (3) For supply voltages less than ±15V, the absolute maximum input voltage is equal to the supply voltage.
- (4) Continuous short circuit is allowed for case temperatures to 125°C and ambient temperatures to 75°C for LM101A/LM201A, and 70°C and 55°C respectively for LM301A.
- (5) Human body model, 100 pF discharged through 1.5 kΩ.

Electrical Characteristics⁽¹⁾

$T_A = T_J$

Parameter	Test Conditions	LM101A/LM201A			LM301A			Units	
		Min	Typ	Max	Min	Typ	Max		
Input Offset Voltage	$T_A = 25^\circ\text{C}$, $R_S \leq 50\text{ k}\Omega$		0.7	2.0		2.0	7.5	mV	
Input Offset Current	$T_A = 25^\circ\text{C}$		1.5	10		3.0	50	nA	
Input Bias Current	$T_A = 25^\circ\text{C}$		30	75		70	250	nA	
Input Resistance	$T_A = 25^\circ\text{C}$	1.5	4.0		0.5	2.0		M Ω	
Supply Current	$T_A = 25^\circ\text{C}$	$V_S = \pm 20\text{V}$		1.8	3.0				mA
		$V_S = \pm 15\text{V}$					1.8	3.0	mA
Large Signal Voltage Gain	$T_A = 25^\circ\text{C}$, $V_S = \pm 15\text{V}$ $V_{OUT} = \pm 10\text{V}$, $R_L \geq 2\text{ k}\Omega$	50	160		25	160		V/mV	
Input Offset Voltage	$R_S \leq 50\text{ k}\Omega$			3.0			10	mV	
Average Temperature Coefficient of Input Offset Voltage	$R_S \leq 50\text{ k}\Omega$		3.0	15		6.0	30	$\mu\text{V}/^\circ\text{C}$	
Input Offset Current				20			70	nA	
Average Temperature Coefficient of Input Offset Current	$25^\circ\text{C} \leq T_A \leq T_{MAX}$ $T_{MIN} \leq T_A \leq 25^\circ\text{C}$		0.01	0.1		0.01	0.3	nA/ $^\circ\text{C}$	
			0.02	0.2		0.02	0.6	nA/ $^\circ\text{C}$	
Input Bias Current				0.1			0.3	μA	
Supply Current	$T_A = T_{MAX}$, $V_S = \pm 20\text{V}$		1.2	2.5				mA	
Large Signal Voltage Gain	$V_S = \pm 15\text{V}$, $V_{OUT} = \pm 10\text{V}$ $R_L \geq 2\text{ k}\Omega$	25			15			V/mV	
Output Voltage Swing	$V_S = \pm 15\text{V}$	$R_L = 10\text{ k}\Omega$	± 12	± 14		± 12	± 14	V	
		$R_L = 2\text{ k}\Omega$	± 10	± 13		± 10	± 13	V	
Input Voltage Range	$V_S = \pm 20\text{V}$	± 15						V	
	$V_S = \pm 15\text{V}$		+15, -13		± 12	+15, -13		V	
Common-Mode Rejection Ratio	$R_S \leq 50\text{ k}\Omega$	80	96		70	90		dB	
Supply Voltage Rejection Ratio	$R_S \leq 50\text{ k}\Omega$	80	96		70	96		dB	

(1) Unless otherwise specified, these specifications apply for $C_1 = 30\text{ pF}$, $\pm 5\text{V} \leq V_S \leq \pm 20\text{V}$ and $-55^\circ\text{C} \leq T_A \leq +125^\circ\text{C}$ (LM101A), $\pm 5\text{V} \leq V_S \leq \pm 20\text{V}$ and $-25^\circ\text{C} \leq T_A \leq +85^\circ\text{C}$ (LM201A), $\pm 5\text{V} \leq V_S \leq \pm 15\text{V}$ and $0^\circ\text{C} \leq T_A \leq +70^\circ\text{C}$ (LM301A).

Typical Performance Characteristics

LM101A/LM201A

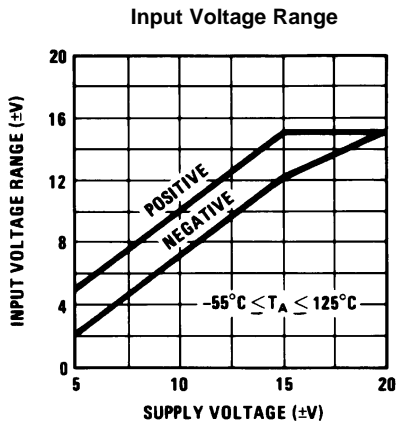

Figure 1.

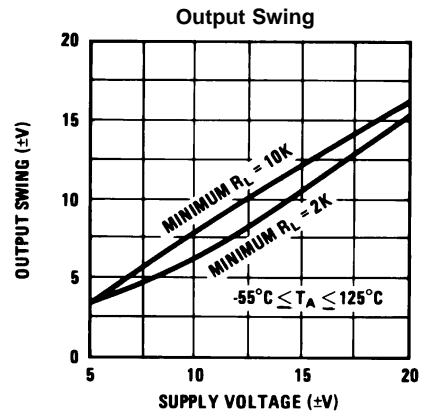

Figure 2.

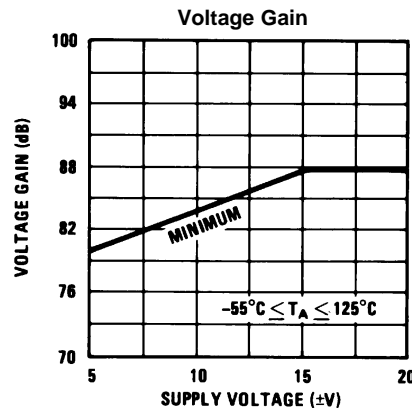

Figure 3.

Performance Characteristics

LM301A

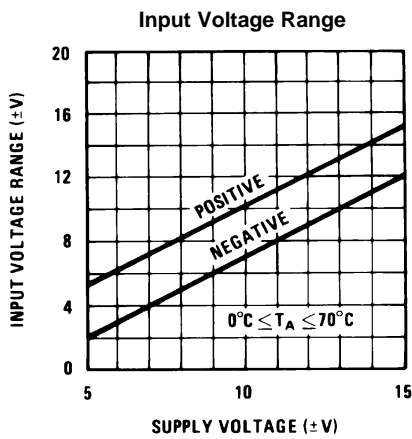

Figure 4.

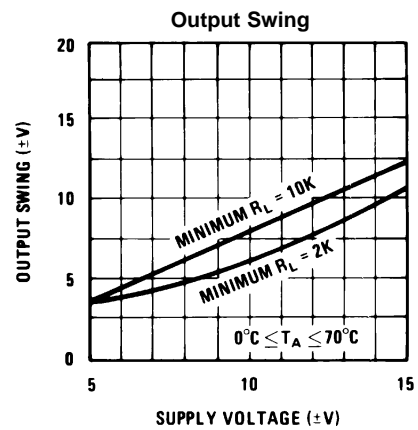

Figure 5.

Performance Characteristics (continued)

LM301A

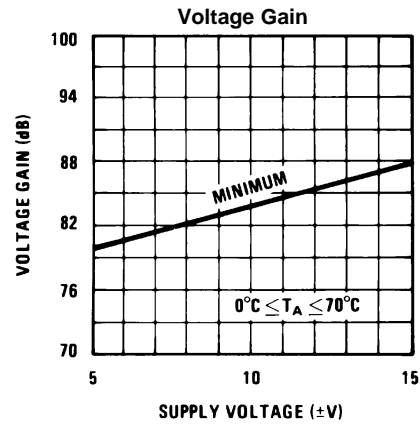

Figure 6.

Typical Performance Characteristics

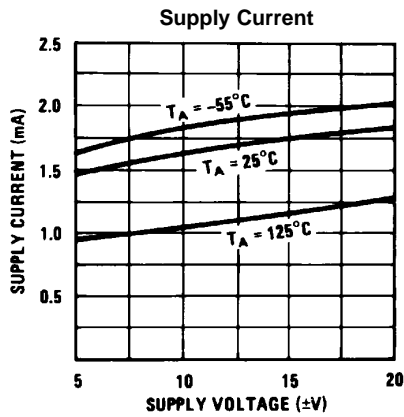

Figure 7.

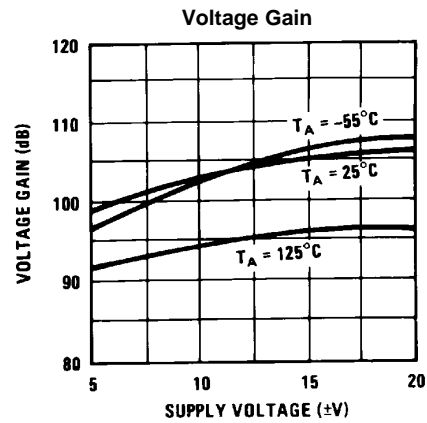

Figure 8.

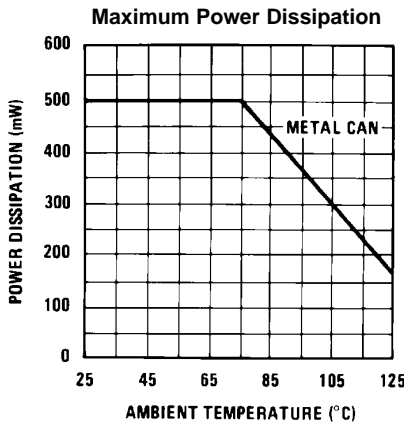

Figure 9.

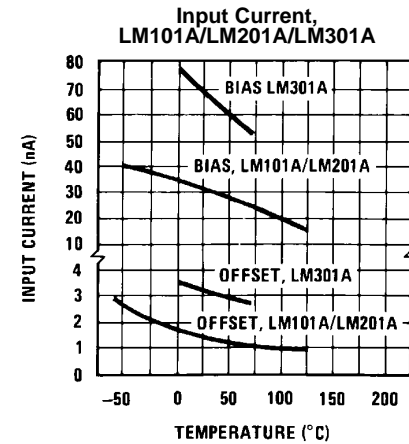

Figure 10.

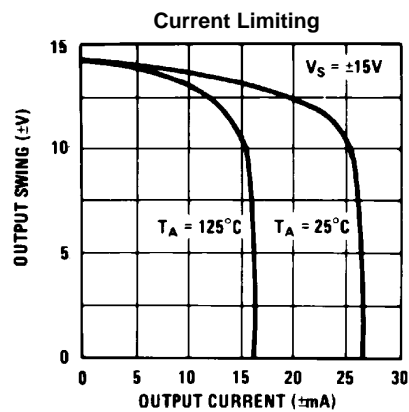

Figure 11.

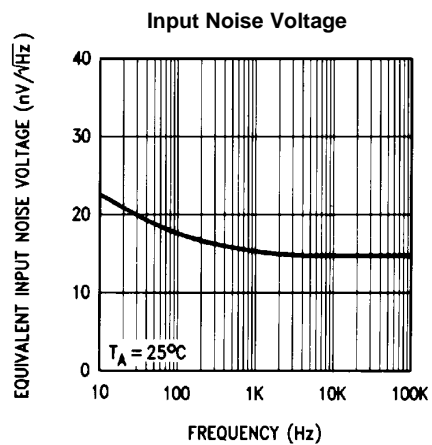

Figure 12.

Typical Performance Characteristics (continued)

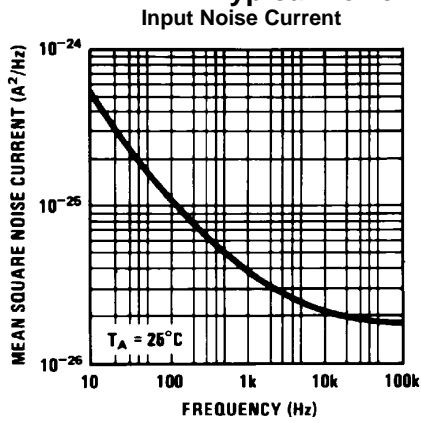

Figure 13.

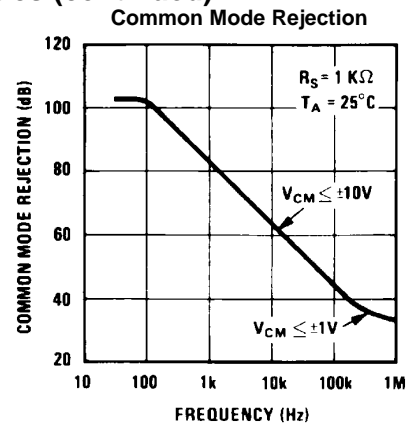

Figure 14.

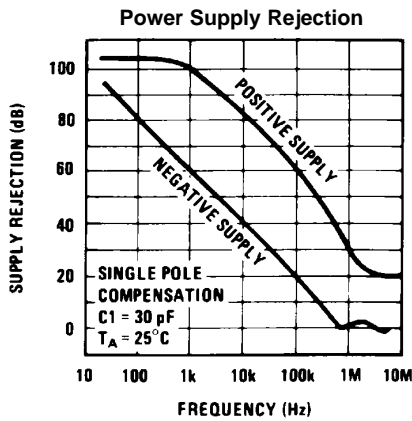

Figure 15.

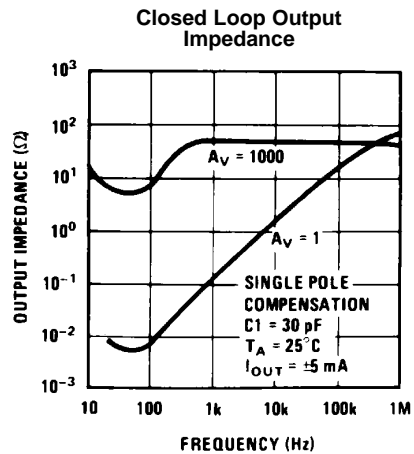
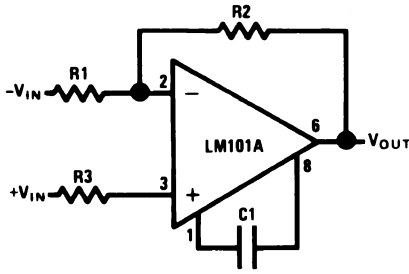

Figure 16.

Typical Performance Characteristics for Various Compensation Circuits

Pin connections shown are for 8-pin packages.



$$C1 \geq \frac{R1 C_S}{R1 + R2}$$

$$C_S = 30 \text{ pF}$$

Figure 17. Single Pole Compensation

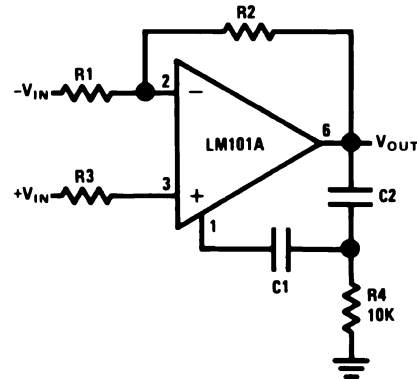

$$C1 \geq \frac{R1 C_S}{R1 + R2}$$

$$C_S = 30 \text{ pF}$$

$$C2 = 10 C1$$

Figure 18. Two Pole Compensation

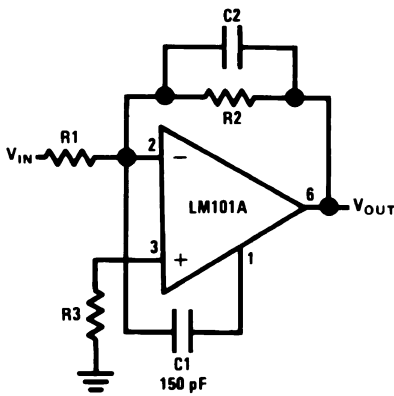

$$C2 = \frac{1}{2\pi f_0 R2}$$

$$f_0 = 3 \text{ MHz}$$

Figure 19. Feedforward Compensation

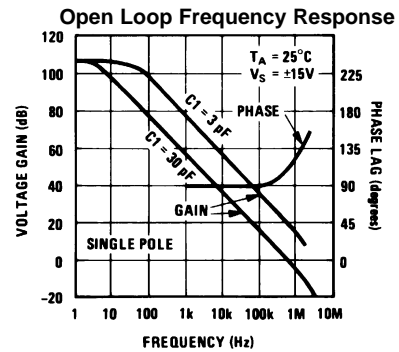

Figure 20.

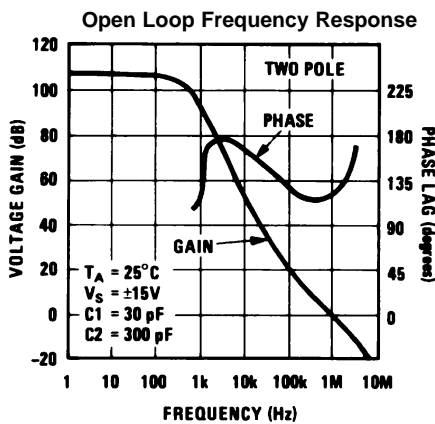

Figure 21.

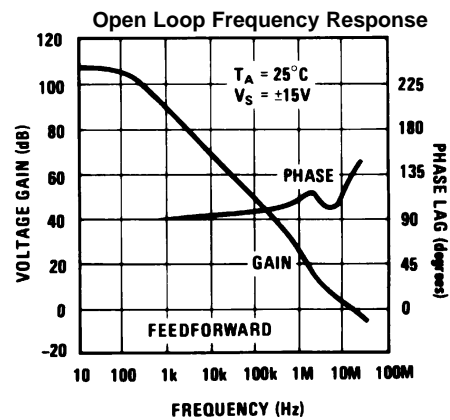

Figure 22.

Typical Performance Characteristics for Various Compensation Circuits (continued)

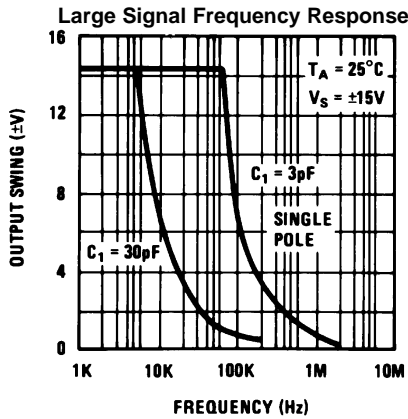

Figure 23.

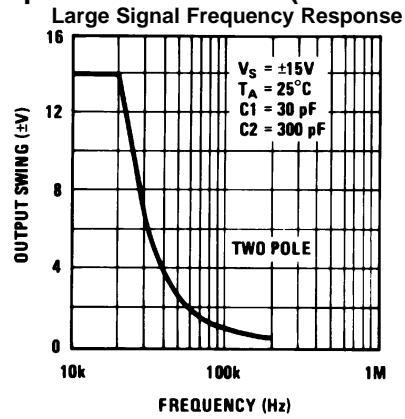

Figure 24.

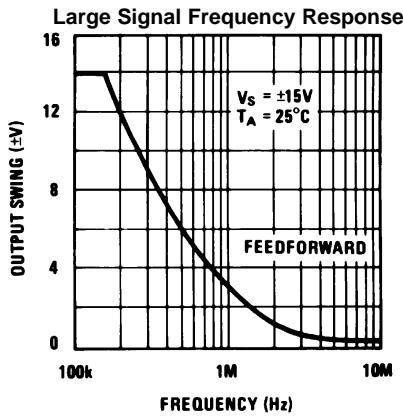

Figure 25.

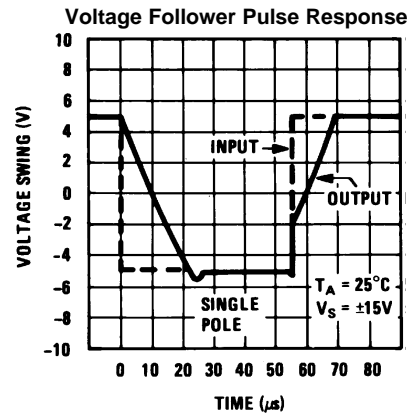

Figure 26.

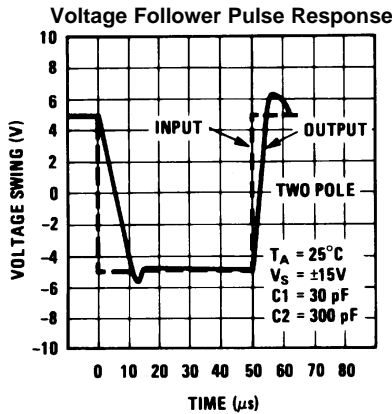

Figure 27.

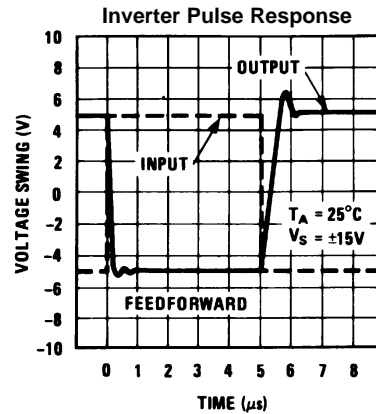
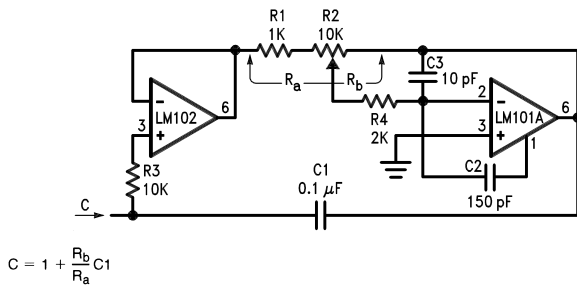

Figure 28.

TYPICAL APPLICATIONS

Pin connections shown are for 8-pin packages



$$C = 1 + \frac{R_b}{R_a} C_1$$

Figure 29. Variable Capacitance Multiplier

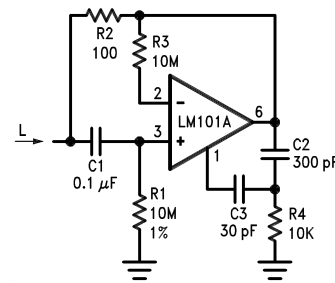

$$L = R_1 R_2 C_1$$

$$R_S = R_2$$

$$R_P = R_1$$

Figure 30. Simulated Inductor

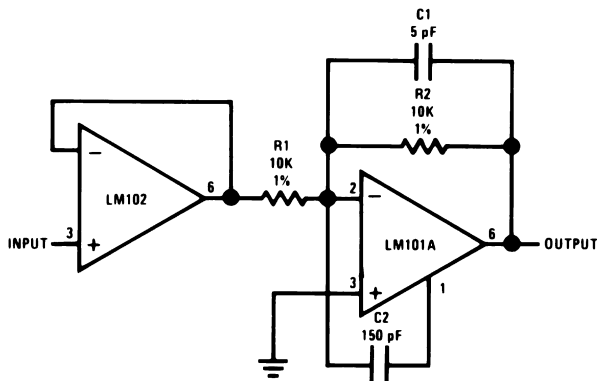
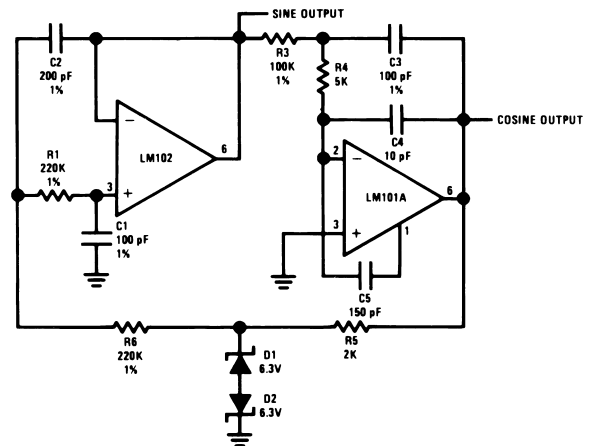
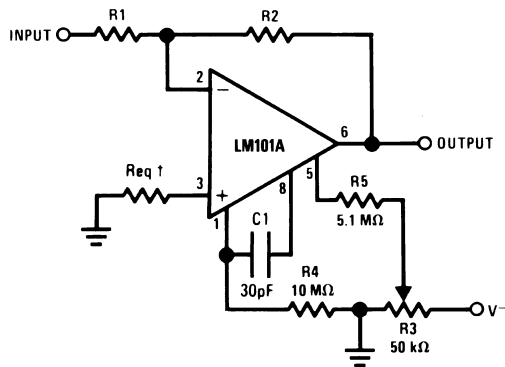

Figure 31. Fast Inverting Amplifier with High Input Impedance



f_o = 10 kHz

Figure 33. Sine Wave Oscillator



†May be zero or equal to parallel combination of R1 and R2 for minimum offset.

Figure 32. Inverting Amplifier with Balancing Circuit

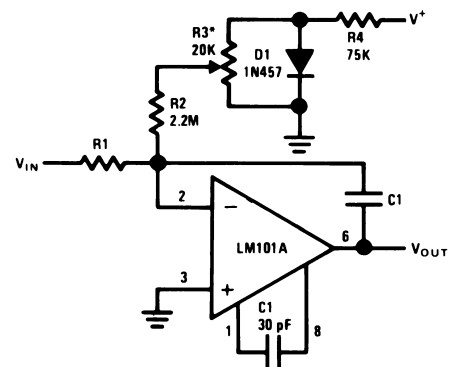

*Adjust for zero integrator drift. Current drift typically 0.1 nA/°C over -55°C to +125°C temperature range.

Figure 34. Integrator with Bias Current Compensation

Application Hints

Pin connections shown are for 8-pin packages.

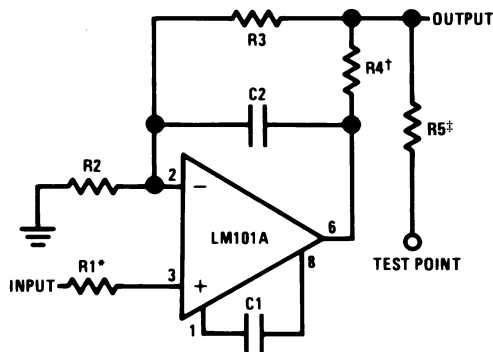

*Protects input

†Protects output

‡Protects output—not needed when R4 is used.

Figure 35. Protecting Against Gross Fault Conditions

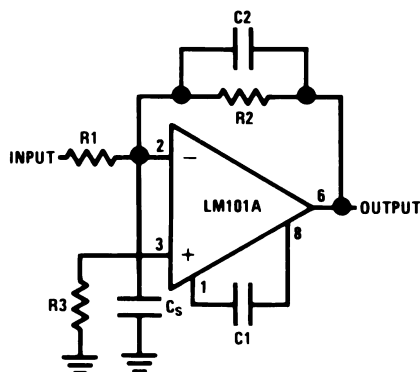

$$C_2 = \frac{R_1 C_s}{R_2}$$

Figure 36. Compensating for Stray Input Capacitances or Large Feedback Resistor

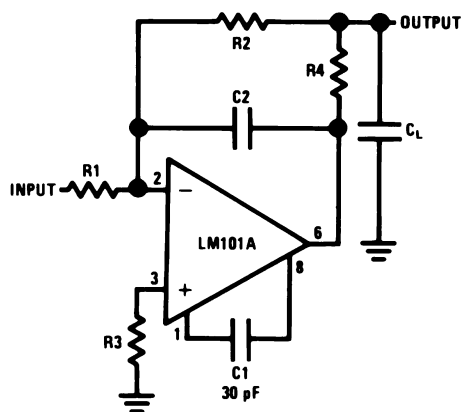

Figure 37. Isolating Large Capacitive Loads

Although the LM101A is designed for trouble free operation, experience has indicated that it is wise to observe certain precautions given below to protect the devices from abnormal operating conditions. It might be pointed out that the advice given here is applicable to practically any IC op amp, although the exact reason why may differ with different devices.

When driving either input from a low-impedance source, a limiting resistor should be placed in series with the input lead to limit the peak instantaneous output current of the source to something less than 100 mA. This is especially important when the inputs go outside a piece of equipment where they could accidentally be connected to high voltage sources. Large capacitors on the input (greater than 0.1 μF) should be treated as a low source impedance and isolated with a resistor. Low impedance sources do not cause a problem unless their output voltage exceeds the supply voltage. However, the supplies go to zero when they are turned off, so the isolation is usually needed.

The output circuitry is protected against damage from shorts to ground. However, when the amplifier output is connected to a test point, it should be isolated by a limiting resistor, as test points frequently get shorted to bad places. Further, when the amplifier drives a load external to the equipment, it is also advisable to use some sort of limiting resistance to preclude mishaps.

Precautions should be taken to insure that the power supplies for the integrated circuit never become reversed—even under transient conditions. With reverse voltages greater than 1V, the IC will conduct excessive current, fusing internal aluminum interconnects. If there is a possibility of this happening, clamp diodes with a high peak current rating should be installed on the supply lines. Reversal of the voltage between V^+ and V^- will always cause a problem, although reversals with respect to ground may also give difficulties in many circuits.

The minimum values given for the frequency compensation capacitor are stable only for source resistances less than 10 k Ω , stray capacitances on the summing junction less than 5 pF and capacitive loads smaller than 100 pF. If any of these conditions are not met, it becomes necessary to overcompensate the amplifier with a larger compensation capacitor. Alternately, lead capacitors can be used in the feedback network to negate the effect of stray capacitance and large feedback resistors or an RC network can be added to isolate capacitive loads.

Although the LM101A is relatively unaffected by supply bypassing, this cannot be ignored altogether. Generally it is necessary to bypass the supplies to ground at least once on every circuit card, and more bypass points may be required if more than five amplifiers are used. When feed-forward compensation is employed, however, it is advisable to bypass the supply leads of each amplifier with low inductance capacitors because of the higher frequencies involved.

Typical Applications

Pin connections shown are for 8-pin packages.

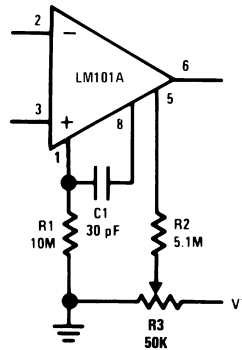
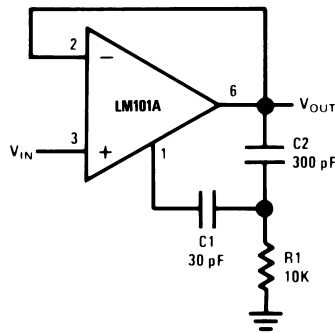
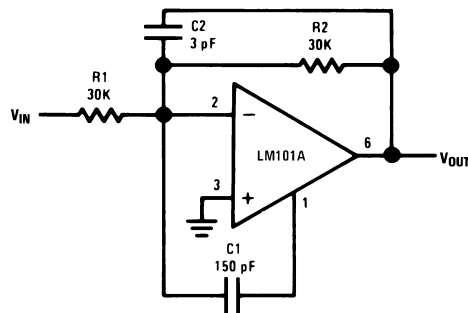

Figure 38. Standard Compensation and Offset Balancing Circuit



Power Bandwidth: 15 kHz
Slew Rate: 1V/ μ s

Figure 39. Fast Voltage Follower



Power Bandwidth: 250 kHz
Small Signal Bandwidth: 3.5 MHz
Slew Rate: 10V/ μ s

Figure 40. Fast Summing Amplifier

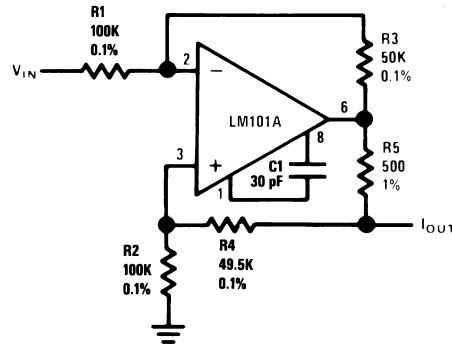

$$I_{OUT} = \frac{R3 V_{IN}}{R1 R5}$$

$$R3 = R4 + R5$$

$$R1 = R2$$

Figure 41. Bilateral Current Source

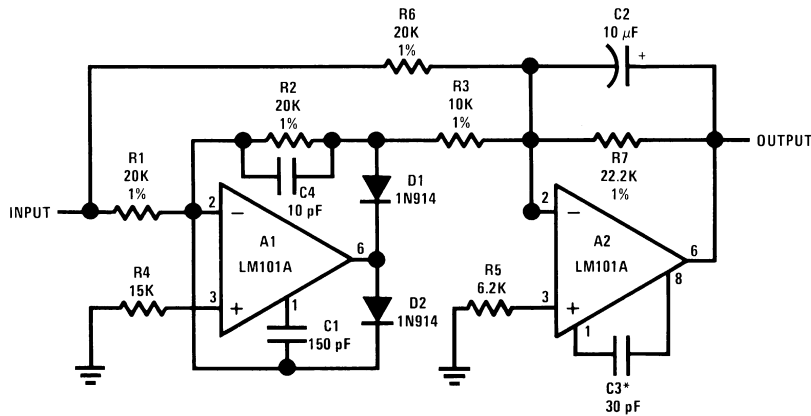
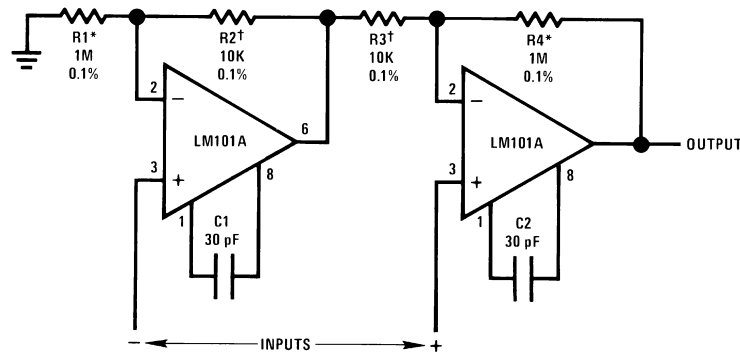

Figure 42. Fast AC/DC Converter⁽¹⁾



$$R1 = R4; R2 = R3$$

$$A_v = 1 + \frac{R1}{R2}$$

* † Matching determines CMRR.

Figure 43. Instrumentation Amplifier

(1) Feedforward compensation can be used to make a fast full wave rectifier without a filter

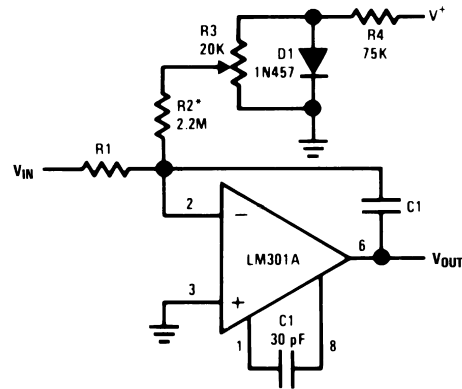

*Adjust for zero integrator drift. Current drift typically 0.1 nA/°C over 0°C to +70°C temperature range.

Figure 44. Integrator with Bias Current Compensation

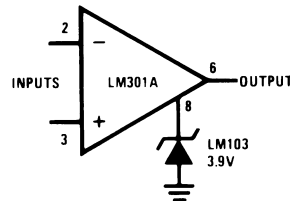

Figure 45. Voltage Comparator for Driving RTL Logic or High Current Driver

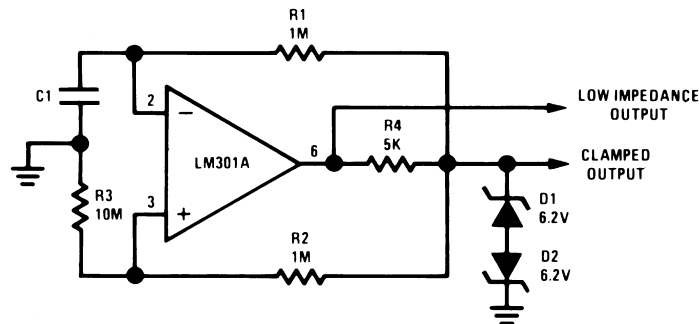
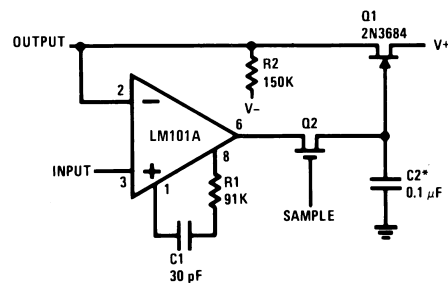

Figure 46. Low Frequency Square Wave Generator



*Polycarbonate-dielectric capacitor

Figure 47. Low Drift Sample and Hold

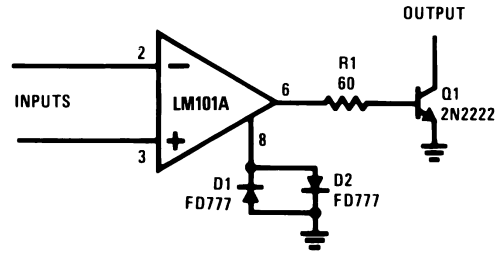
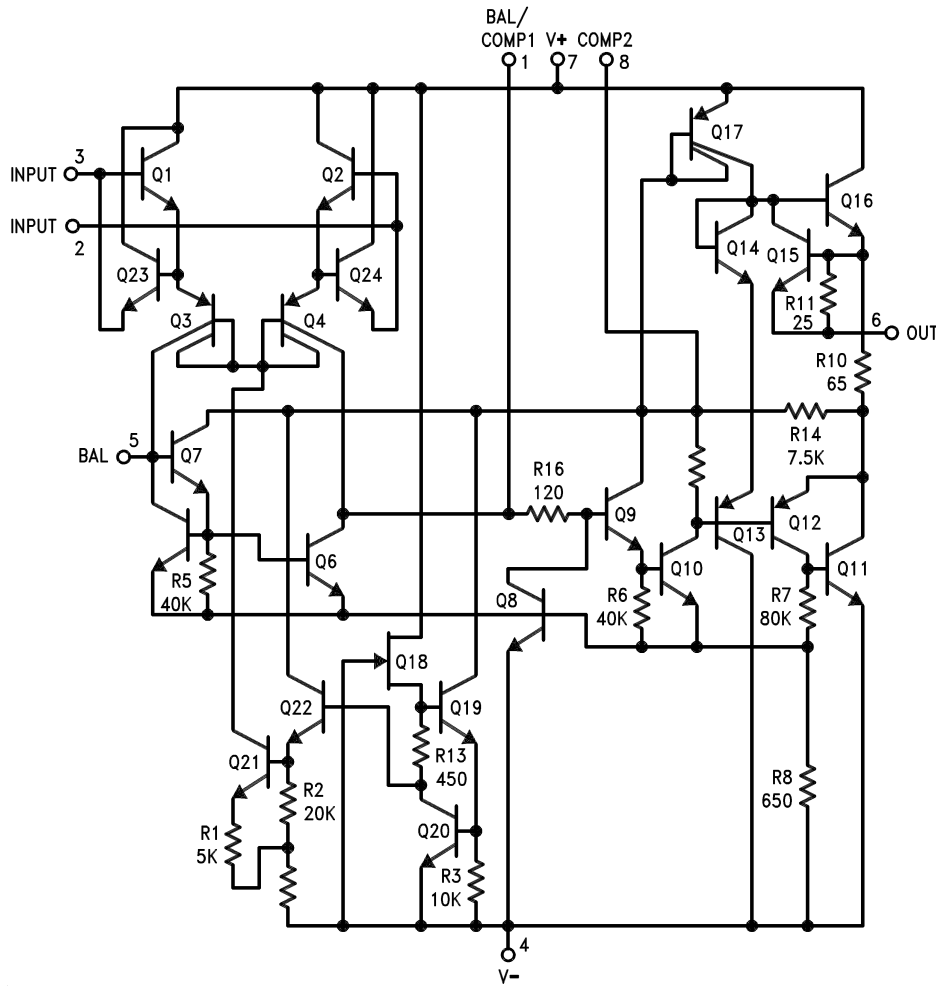

Figure 48. Voltage Comparator for Driving DTL or TTL Integrated Circuits

Schematic



Pin connections shown are for 8-pin packages.

Connection Diagrams

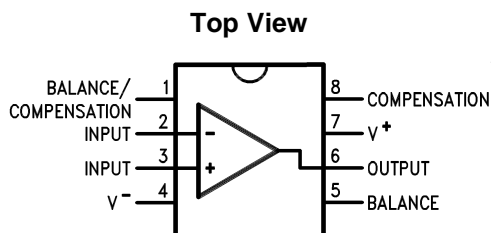

Figure 49. CDIP and PDIP Packages
Package Number NAB0008A or P0008E

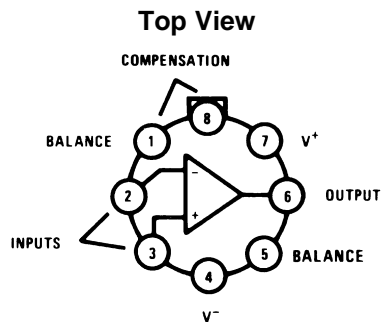

Figure 51. TO-99 Package
See Package Number LMC0008C

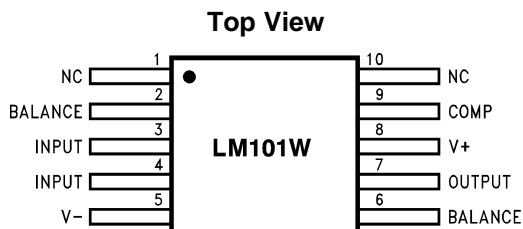

Figure 50. CLGA Package
Package Number NAD0010A

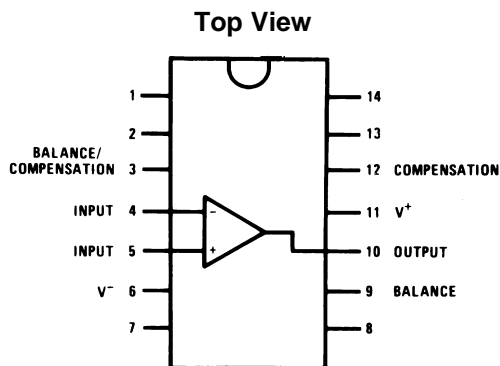

Figure 52. CDIP Package
See Package Number J0014A,

REVISION HISTORY

Changes from Revision C (March 2013) to Revision D

Page

-
- Changed layout of National Data Sheet to TI format [17](#)
-

PACKAGING INFORMATION

Orderable Device	Status (1)	Package Type	Package Drawing	Pins	Package Qty	Eco Plan (2)	Lead/Ball Finish (6)	MSL Peak Temp (3)	Op Temp (°C)	Device Marking (4/5)	Samples
LM101AH	ACTIVE	TO-99	LMC	8	500	TBD	Call TI	Call TI	-55 to 125	LM101AH	Samples
LM101AH/NOPB	ACTIVE	TO-99	LMC	8	500	Green (RoHS & no Sb/Br)	POST-PLATE	Level-1-NA-UNLIM	-55 to 125	LM101AH	Samples
LM101AJ	ACTIVE	CDIP	NAB	8	40	TBD	Call TI	Call TI	-55 to 125	LM101AJ	Samples
LM201AH	ACTIVE	TO-99	LMC	8	500	TBD	Call TI	Call TI	-40 to 85	LM201AH	Samples
LM201AH/NOPB	ACTIVE	TO-99	LMC	8	500	Green (RoHS & no Sb/Br)	POST-PLATE	Level-1-NA-UNLIM	-40 to 85	LM201AH	Samples
LM301AH	ACTIVE	TO-99	LMC	8	500	TBD	Call TI	Call TI	0 to 70	LM301AH	Samples
LM301AH/NOPB	ACTIVE	TO-99	LMC	8	500	Green (RoHS & no Sb/Br)	POST-PLATE	Level-1-NA-UNLIM	0 to 70	LM301AH	Samples
LM301AN	NRND	PDIP	P	8	40	TBD	Call TI	Call TI	0 to 70	LM301AN	
LM301AN/NOPB	ACTIVE	PDIP	P	8	40	Green (RoHS & no Sb/Br)	CU SN	Level-1-NA-UNLIM	0 to 70	LM301AN	Samples

(1) The marketing status values are defined as follows:

ACTIVE: Product device recommended for new designs.

LIFEBUY: TI has announced that the device will be discontinued, and a lifetime-buy period is in effect.

NRND: Not recommended for new designs. Device is in production to support existing customers, but TI does not recommend using this part in a new design.

PREVIEW: Device has been announced but is not in production. Samples may or may not be available.

OBSELETE: TI has discontinued the production of the device.

(2) Eco Plan - The planned eco-friendly classification: Pb-Free (RoHS), Pb-Free (RoHS Exempt), or Green (RoHS & no Sb/Br) - please check <http://www.ti.com/productcontent> for the latest availability information and additional product content details.

TBD: The Pb-Free/Green conversion plan has not been defined.

Pb-Free (RoHS): TI's terms "Lead-Free" or "Pb-Free" mean semiconductor products that are compatible with the current RoHS requirements for all 6 substances, including the requirement that lead not exceed 0.1% by weight in homogeneous materials. Where designed to be soldered at high temperatures, TI Pb-Free products are suitable for use in specified lead-free processes.

Pb-Free (RoHS Exempt): This component has a RoHS exemption for either 1) lead-based flip-chip solder bumps used between the die and package, or 2) lead-based die adhesive used between the die and leadframe. The component is otherwise considered Pb-Free (RoHS compatible) as defined above.

Green (RoHS & no Sb/Br): TI defines "Green" to mean Pb-Free (RoHS compatible), and free of Bromine (Br) and Antimony (Sb) based flame retardants (Br or Sb do not exceed 0.1% by weight in homogeneous material)

(3) MSL, Peak Temp. - The Moisture Sensitivity Level rating according to the JEDEC industry standard classifications, and peak solder temperature.

(4) There may be additional marking, which relates to the logo, the lot trace code information, or the environmental category on the device.

(5) Multiple Device Markings will be inside parentheses. Only one Device Marking contained in parentheses and separated by a "~" will appear on a device. If a line is indented then it is a continuation of the previous line and the two combined represent the entire Device Marking for that device.

(6) Lead/Ball Finish - Orderable Devices may have multiple material finish options. Finish options are separated by a vertical ruled line. Lead/Ball Finish values may wrap to two lines if the finish value exceeds the maximum column width.

Important Information and Disclaimer:The information provided on this page represents TI's knowledge and belief as of the date that it is provided. TI bases its knowledge and belief on information provided by third parties, and makes no representation or warranty as to the accuracy of such information. Efforts are underway to better integrate information from third parties. TI has taken and continues to take reasonable steps to provide representative and accurate information but may not have conducted destructive testing or chemical analysis on incoming materials and chemicals. TI and TI suppliers consider certain information to be proprietary, and thus CAS numbers and other limited information may not be available for release.

In no event shall TI's liability arising out of such information exceed the total purchase price of the TI part(s) at issue in this document sold by TI to Customer on an annual basis.

NAB0008A

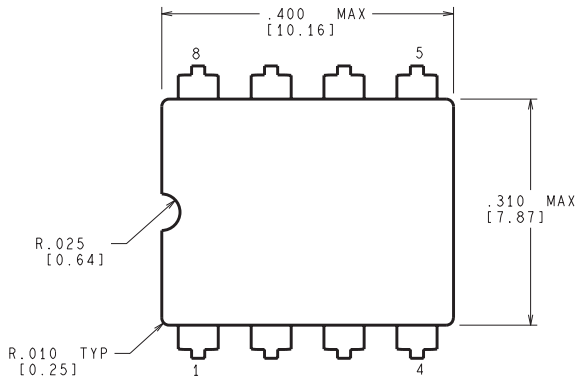

CONTROLLING DIMENSION IS INCH
VALUES IN [] ARE MILLIMETERS

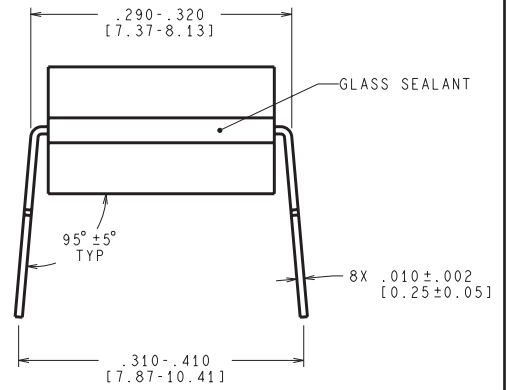
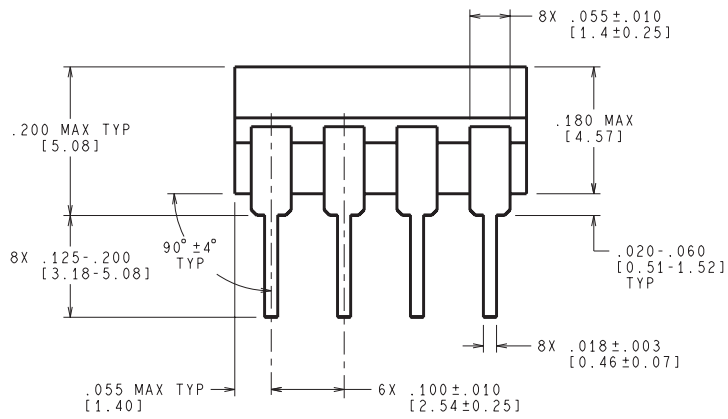

J08A (Rev M)

LMC (O-MBCY-W8)

METAL CYLINDRICAL PACKAGE

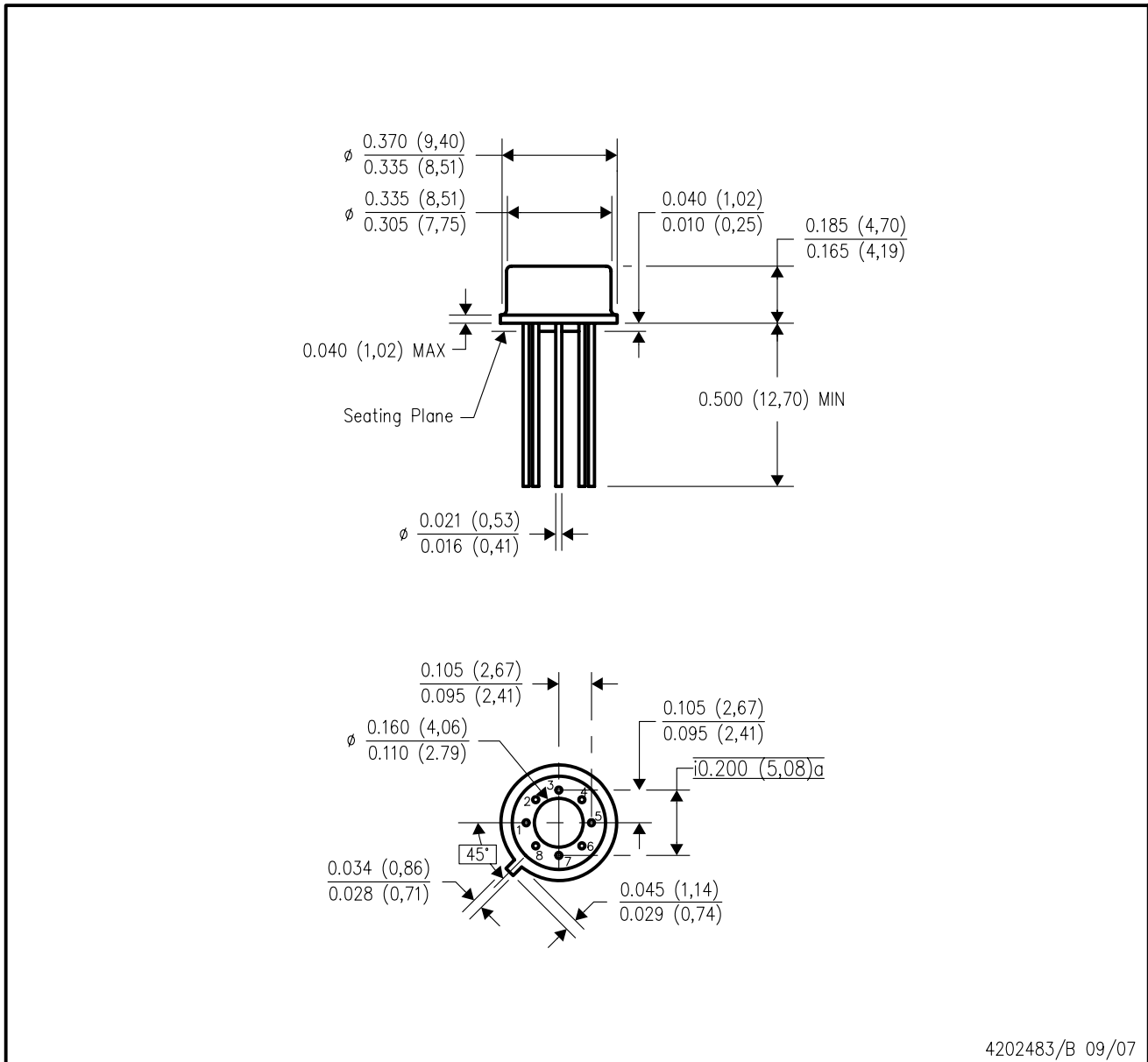

- NOTES:
- A. All linear dimensions are in inches (millimeters).
 - B. This drawing is subject to change without notice.
 - C. Leads in true position within 0.010 (0,25) R @ MMC at seating plane.
 - D. Pin numbers shown for reference only. Numbers may not be marked on package.
 - E. Falls within JEDEC MO-002/TO-99.

P (R-PDIP-T8)

PLASTIC DUAL-IN-LINE PACKAGE



- NOTES:
- A. All linear dimensions are in inches (millimeters).
 - B. This drawing is subject to change without notice.
 - C. Falls within JEDEC MS-001 variation BA.

IMPORTANT NOTICE

Texas Instruments Incorporated and its subsidiaries (TI) reserve the right to make corrections, enhancements, improvements and other changes to its semiconductor products and services per JESD46, latest issue, and to discontinue any product or service per JESD48, latest issue. Buyers should obtain the latest relevant information before placing orders and should verify that such information is current and complete. All semiconductor products (also referred to herein as "components") are sold subject to TI's terms and conditions of sale supplied at the time of order acknowledgment.

TI warrants performance of its components to the specifications applicable at the time of sale, in accordance with the warranty in TI's terms and conditions of sale of semiconductor products. Testing and other quality control techniques are used to the extent TI deems necessary to support this warranty. Except where mandated by applicable law, testing of all parameters of each component is not necessarily performed.

TI assumes no liability for applications assistance or the design of Buyers' products. Buyers are responsible for their products and applications using TI components. To minimize the risks associated with Buyers' products and applications, Buyers should provide adequate design and operating safeguards.

TI does not warrant or represent that any license, either express or implied, is granted under any patent right, copyright, mask work right, or other intellectual property right relating to any combination, machine, or process in which TI components or services are used. Information published by TI regarding third-party products or services does not constitute a license to use such products or services or a warranty or endorsement thereof. Use of such information may require a license from a third party under the patents or other intellectual property of the third party, or a license from TI under the patents or other intellectual property of TI.

Reproduction of significant portions of TI information in TI data books or data sheets is permissible only if reproduction is without alteration and is accompanied by all associated warranties, conditions, limitations, and notices. TI is not responsible or liable for such altered documentation. Information of third parties may be subject to additional restrictions.

Resale of TI components or services with statements different from or beyond the parameters stated by TI for that component or service voids all express and any implied warranties for the associated TI component or service and is an unfair and deceptive business practice. TI is not responsible or liable for any such statements.

Buyer acknowledges and agrees that it is solely responsible for compliance with all legal, regulatory and safety-related requirements concerning its products, and any use of TI components in its applications, notwithstanding any applications-related information or support that may be provided by TI. Buyer represents and agrees that it has all the necessary expertise to create and implement safeguards which anticipate dangerous consequences of failures, monitor failures and their consequences, lessen the likelihood of failures that might cause harm and take appropriate remedial actions. Buyer will fully indemnify TI and its representatives against any damages arising out of the use of any TI components in safety-critical applications.

In some cases, TI components may be promoted specifically to facilitate safety-related applications. With such components, TI's goal is to help enable customers to design and create their own end-product solutions that meet applicable functional safety standards and requirements. Nonetheless, such components are subject to these terms.

No TI components are authorized for use in FDA Class III (or similar life-critical medical equipment) unless authorized officers of the parties have executed a special agreement specifically governing such use.

Only those TI components which TI has specifically designated as military grade or "enhanced plastic" are designed and intended for use in military/aerospace applications or environments. Buyer acknowledges and agrees that any military or aerospace use of TI components which have **not** been so designated is solely at the Buyer's risk, and that Buyer is solely responsible for compliance with all legal and regulatory requirements in connection with such use.

TI has specifically designated certain components as meeting ISO/TS16949 requirements, mainly for automotive use. In any case of use of non-designated products, TI will not be responsible for any failure to meet ISO/TS16949.

Products

Audio	www.ti.com/audio
Amplifiers	amplifier.ti.com
Data Converters	dataconverter.ti.com
DLP® Products	www.dlp.com
DSP	dsp.ti.com
Clocks and Timers	www.ti.com/clocks
Interface	interface.ti.com
Logic	logic.ti.com
Power Mgmt	power.ti.com
Microcontrollers	microcontroller.ti.com
RFID	www.ti-rfid.com
OMAP Applications Processors	www.ti.com/omap
Wireless Connectivity	www.ti.com/wirelessconnectivity

Applications

Automotive and Transportation	www.ti.com/automotive
Communications and Telecom	www.ti.com/communications
Computers and Peripherals	www.ti.com/computers
Consumer Electronics	www.ti.com/consumer-apps
Energy and Lighting	www.ti.com/energy
Industrial	www.ti.com/industrial
Medical	www.ti.com/medical
Security	www.ti.com/security
Space, Avionics and Defense	www.ti.com/space-avionics-defense
Video and Imaging	www.ti.com/video

TI E2E Community

e2e.ti.com

AMEYA360

Components Supply Platform

Authorized Distribution Brand :



Website :

Welcome to visit www.ameya360.com

Contact Us :

➤ Address :

401 Building No.5, JiuGe Business Center, Lane 2301, Yishan Rd
Minhang District, Shanghai , China

➤ Sales :

Direct +86 (21) 6401-6692

Email amall@ameya360.com

QQ 800077892

Skype [ameyasales1](#) [ameyasales2](#)

➤ Customer Service :

Email service@ameya360.com

➤ Partnership :

Tel +86 (21) 64016692-8333

Email mkt@ameya360.com