

1.2A High Voltage Boost Converter in 2x2mm² QFN Package

Check for Samples: [TPS61170-Q1](#)

FEATURES

- Qualified for Automotive Applications
- 3-V to 18-V Input Voltage Range
- High Output Voltage: Up to 38 V
- 1.2-A integrated Switch
- 1.2-MHz Fixed Switching Frequency
- 12 V at 300 mA and 24 V at 150 mA from 5-V Input (Typical)
- Up to 93% Efficiency
- *On-The-Fly* Output Voltage Reprogramming
- Skip-Switching Cycle for Output Regulation at Light Load
- Built-in Soft Start
- 6-Pin, 2 mm × 2 mm QFN Package

APPLICATIONS

- 5-V to 12-V and 24-V, 12-V to 24-V Boost Converter
- Buck Boost Regulation Using SEPIC Topology

DESCRIPTION

The TPS61170-Q1 is a monolithic, high-voltage switching regulator with integrated 1.2-A, 40-V power MOSFET. It can be configured in several standard switching-regulator topologies, including boost and SEPIC. The device has a wide input-voltage range to support applications with input voltage from multi-cell batteries or regulated 5-V, 12-V power rails.

The TPS61170-Q1 operates at a 1.2-MHz switching frequency, allowing the use of low-profile inductors and low-value ceramic input and output capacitors. External loop compensation components give the user flexibility to optimize loop compensation and transient response. The device has built-in protection features, such as pulse-by-pulse overcurrent limit, soft start and thermal shutdown.

The reference voltage to which the FB pin regulates is 1.229V. The reference voltage can be lowered using a 1-wire digital interface (Easyscale™ protocol) through the CTRL pin. Alternatively, a pulse width-modulation (PWM) signal can be applied to the CTRL pin. The duty cycle of the signal reduces the feedback reference voltage proportionally.

The TPS61170-Q1 is available in a 6-pin 2 mm × 2 mm QFN package, allowing a compact power-supply solution.

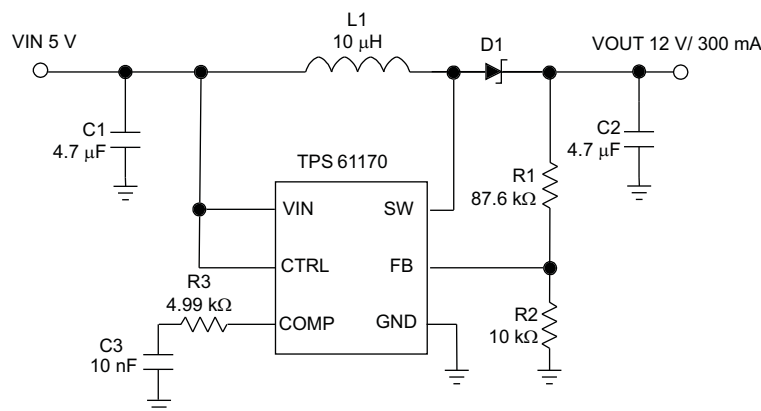

L1: TOKO#A915_Y-100M
C1: Murata GRM188R61A475K
C2: Murata GRM21BR61E475K
D1: ONsemi MBR0540T1
*R3, C3: Compensation RC network

Figure 1. Typical Application

Please be aware that an important notice concerning availability, standard warranty, and use in critical applications of Texas Instruments semiconductor products and disclaimers thereto appears at the end of this data sheet.



This integrated circuit can be damaged by ESD. Texas Instruments recommends that all integrated circuits be handled with appropriate precautions. Failure to observe proper handling and installation procedures can cause damage.

ESD damage can range from subtle performance degradation to complete device failure. Precision integrated circuits may be more susceptible to damage because very small parametric changes could cause the device not to meet its published specifications.

ORDERING INFORMATION⁽¹⁾

T _A	PACKAGE		ORDERABLE PART NUMBER	TOP-SIDE MARKING
-40°C to 125°C	QFN - DRV	Reel of 3000	TPS61170QDRVRQ1	RAP

(1) For the most current package and ordering information, see the TI Web site at www.ti.com.

ABSOLUTE MAXIMUM RATINGS

over operating free-air temperature range (unless otherwise noted) ⁽¹⁾

		VALUE	UNIT
V _I	Supply Voltages on VIN ⁽²⁾	-0.3 to 20	V
	Voltages on CTRL ⁽²⁾	-0.3 to 20	V
	Voltage on FB and COMP ⁽²⁾	-0.3 to 3	V
	Voltage on SW ⁽²⁾	-0.3 to 40	V
P _D	Continuous Power Dissipation	See Dissipation Ratings Table	
T _J	Operating Junction Temperature Range	-40 to 150	°C
T _{STG}	Storage Temperature Range	-65 to 150	°C

(1) Stresses beyond those listed under *absolute maximum ratings* may cause permanent damage to the device. These are stress ratings only, and functional operation of the device at these or any other conditions beyond those indicated under *recommended operating conditions* is not implied. Exposure to absolute-maximum-rated conditions for extended periods may affect device reliability.

(2) All voltage values are with respect to network ground terminal.

DISSIPATION RATINGS

BOARD PACKAGE	R _{θJC}	R _{θJA}	DERATING FACTOR ABOVE T _A = 25°C	T _A < 25°C	T _A = 70°C	T _A = 85°C
Low-K ⁽¹⁾ DRV	20°C/W	140°C/W	7.1 mW/°C	715 mW	395 mW	285 mW
High-K ⁽²⁾ DRV	20°C/W	65°C/W	15.4 mW/°C	1540 mW	845 mW	615 mW

(1) The JEDEC low-K (1s) board used to derive this data was a 3in×3in, two-layer board with 2-ounce copper traces on top of the board.

(2) The JEDEC high-K (2s2p) board used to derive this data was a 3in×3in, multilayer board with 1-ounce internal power and ground planes and 2-ounce copper traces on top and bottom of the board.

RECOMMENDED OPERATING CONDITIONS

		MIN	TYP	MAX	UNIT
V _I	Input voltage range, VIN	3		18	V
V _O	Output voltage range	V _{IN}		38	V
L	Inductor ⁽¹⁾	10		22	μH
C _I	Input capacitor	1			μF
C _O	Output capacitor ⁽¹⁾	1		10	μF
T _A	Operating ambient temperature	-40		125	°C
T _J	Operating junction temperature	-40		125	°C

(1) These values are recommended values that have been successfully tested in several applications. Other values may be acceptable in other applications but should be fully tested by the user.

ELECTRICAL CHARACTERISTICS

VIN = 3.6 V, CTRL = VIN, TA = –40°C to 125°C, typical values are at TA = 25°C (unless otherwise noted)

PARAMETER		TEST CONDITIONS	MIN	TYP	MAX	UNIT
SUPPLY CURRENT						
VI	Input voltage range, VIN		3.0		18	V
IQ	Operating quiescent current into VIN	Device PWM switching no load			2.3	mA
ISD	Shutdown current	CRTL=GND, VIN = 4.2 V			1	µA
UVLO	Under-voltage lockout threshold	VIN falling		2.2	2.5	V
Vhys	Under-voltage lockout Hysteresis			70		mV
ENABLE AND REFERENCE CONTROL						
V(CTRLh)	CTRL logic high voltage	VIN = 3 V to 18 V	1.2			V
V(CTRLl)	CTRL logic low voltage	VIN = 3 V to 18 V			0.4	V
R(CTRL)	CTRL pull down resistor		400	800	1600	kΩ
t _{off}	CTRL pulse width to shutdown	CTRL high to low	2.5			ms
t _{es_det}	Easy Scale detection time ⁽¹⁾	CTRL pin low	260			µs
t _{es_delay}	Easy Scale detection delay		100			µs
t _{es_win}	Easy Scale detection window time		1			ms
VOLTAGE AND CURRENT CONTROL						
VREF	Voltage feedback regulation voltage		1.204	1.229	1.254	V
V(REF_PWM)	Voltage feedback regulation voltage under reprogram	VFB = 492 mV	477	492	507	mV
IFB	Voltage feedback input bias current	VFB = 1.229 V			200	nA
fS	Oscillator frequency		1.0	1.2	1.5	MHz
D _{max}	Maximum duty cycle	VFB = 100 mV	90%	93%		
t _{min_on}	Minimum on pulse width			40		ns
ISink	Comp pin sink current			100		µA
ISource	Comp pin source current			100		µA
G _{ea}	Error amplifier transconductance		240	320	400	µmho
R _{ea}	Error amplifier output resistance	5 pF connected to COMP		6		MΩ
f _{ea}	Error amplifier crossover frequency	5 pF connected to COMP		500		kHz
POWER SWITCH						
R _{DS(on)}	N-channel MOSFET on-resistance	VIN = 3.6 V		0.3	0.6	Ω
		VIN = 3.0 V			0.7	
ILN_NFET	N-channel leakage current	V _{SW} = 35 V, TA = 25°C			1	µA
OC and SS						
ILIM	N-Channel MOSFET current limit	D = D _{max}	0.96	1.2	1.44	A
ILIM_Start	Start up current limit	D = D _{max}		0.7		A
t _{Half_LIM}	Time step for half current limit			5		ms
t _{REF}	Vref filter time constant			180		µs
t _{step}	VREF ramp up time			213		µs

(1) EasyScale communication is allowed immediately after the CTRL pin has been low for more than t_{es_det}. To select EasyScale™ mode, the CTRL pin must be low for more than t_{es_det} the end of t_{es_win}.

ELECTRICAL CHARACTERISTICS (continued)

VIN = 3.6 V, CTRL = VIN, TA = -40°C to 125°C, typical values are at TA = 25°C (unless otherwise noted)

PARAMETER		TEST CONDITIONS	MIN	TYP	MAX	UNIT
EasyScale TIMING						
t _{start}	Start time of program stream		2			μs
t _{EOS}	End time of program stream		2		360	μs
t _{H_LB}	High time low bit	Logic 0	2		180	μs
t _{L_LB}	Low time low bit	Logic 0		2 × t _{H_LB}	360	μs
t _{H_HB}	High time high bit	Logic 1		2 × t _{L_HB}	360	μs
t _{L_HB}	Low time high bit	Logic 1	2		180	μs
V _{ACKNL}	Acknowledge output voltage low	Open drain, R _{pullup} = 15 kΩ to Vin			0.4	V
t _{valACKN}	Acknowledge valid time	See (2)			2	μs
t _{ACKN}	Duration of acknowledge condition	See (2)			512	μs
THERMAL SHUTDOWN						
T _{shutdown}	Thermal shutdown threshold			160		°C
T _{hysteresis}	Thermal shutdown threshold hysteresis			15		°C

(2) Acknowledge condition active 0, this condition will only be applied if the RFA bit is set. Open drain output, line needs to be pulled high by the host with resistor load.

PIN ASSIGNMENTS

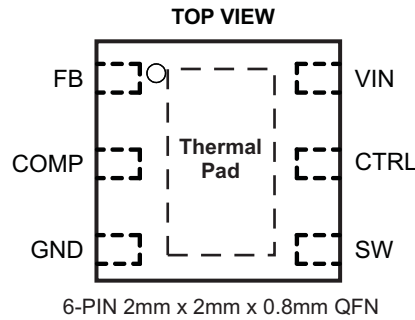

TERMINAL FUNCTIONS

TERMINAL		I/O	DESCRIPTION
NAME	NO.		
VIN	6	I	The input supply pin for the IC. Connect VIN to a supply voltage between 3 V and 18 V.
SW	4	I	This is the switching node of the IC. Connect SW to the switched side of the inductor.
GND	3	O	Ground
FB	1	I	Feedback pin for current. Connect to the center tap of a resistor divider to program the output voltage.
COMP	2	O	Output of the transconductance error amplifier. Connect an external RC network to this pin to compensate the regulator.
CTRL	5	I	Control pin of the boost regulator. CTRL is a multi-functional pin which can be used to enable the device and control the feedback voltage with a PWM signal or for digital communications.
Thermal Pad			The thermal pad should be soldered to the analog ground plane to avoid thermal issue. If possible, use thermal vias to connect to ground plane for ideal power dissipation.

FUNCTIONAL BLOCK DIAGRAM

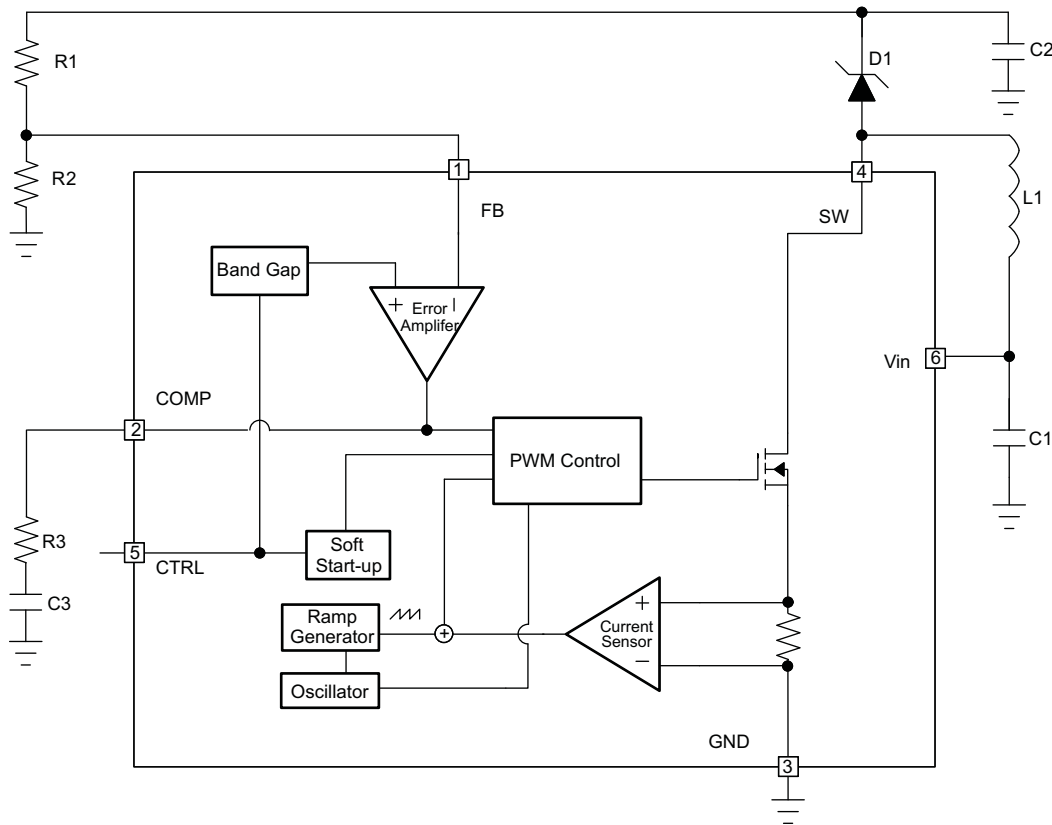

TYPICAL CHARACTERISTICS

TABLE OF GRAPHS

Circuit of Figure 1, L = TOKO A915_Y-100M, D1 = ONsemi MBR0540T1, unless otherwise noted.		FIGURE
Efficiency	VIN = 5V; VOUT = 12V,18V,24V,30V	Figure 2
Efficiency	VIN = 5V, 8.5V, 12V; VOUT = 24V	Figure 3
Output voltage accuracy	I _{LOAD} = 100 mA	Figure 4
Switch current limit	T _A = 25°C	Figure 5
Switch current limit		Figure 6
Error amplifier transconductance		Figure 7
Easyscale step		Figure 8
PWM switching operation	VIN = 5V; VOUT = 12V; I _{LOAD} = 250mA	Figure 9
Load transient response	VIN = 5V; VOUT = 12V; I _{LOAD} = 50mA to 150mA	Figure 10
Start-up	VIN = 5V; VOUT = 12V; I _{LOAD} = 250mA	Figure 11
Skip-cycle switching	VIN = 9V ; VOUT = 12V, I _{LOAD} = 100µA	Figure 12

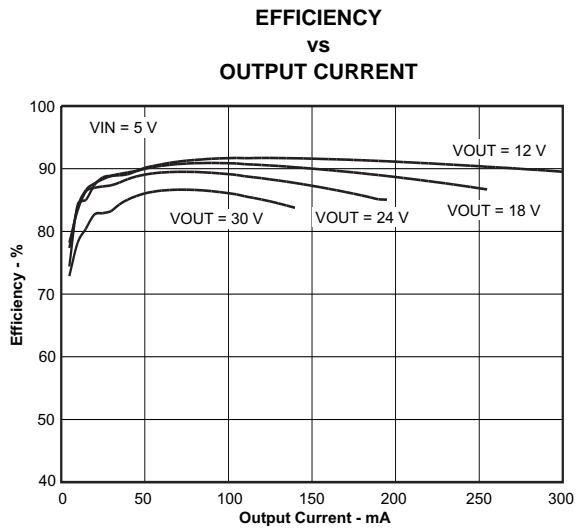

Figure 2.

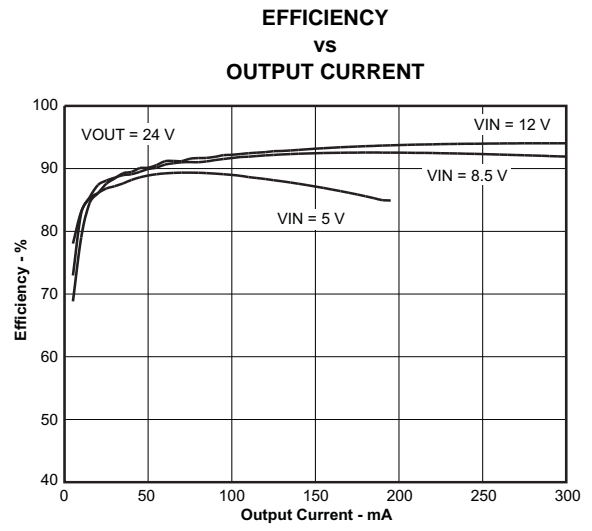

Figure 3.

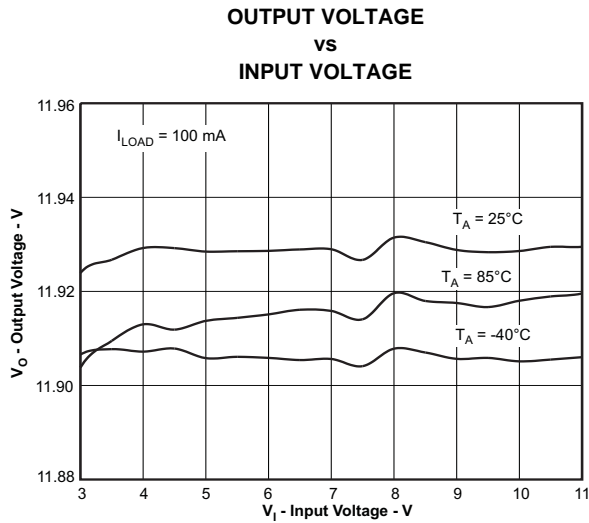

Figure 4.

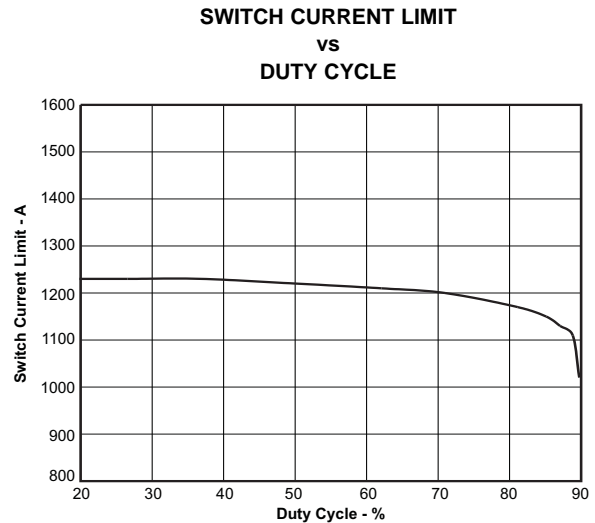

Figure 5.

**SWITCH CURRENT LIMIT
vs
TEMPERATURE**

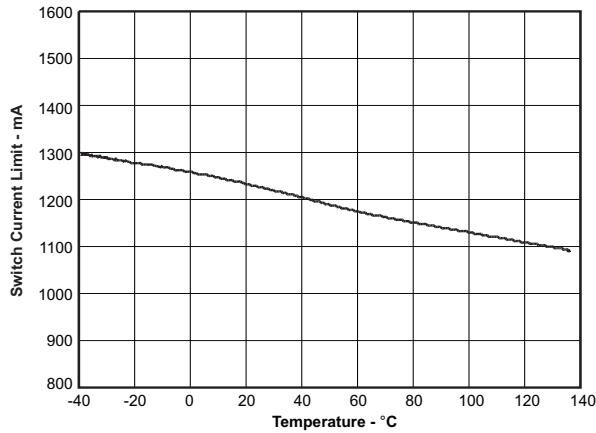

Figure 6.

**ERROR AMPLIFIER TRANSCONDUCTANCE
vs
TEMPERATURE**

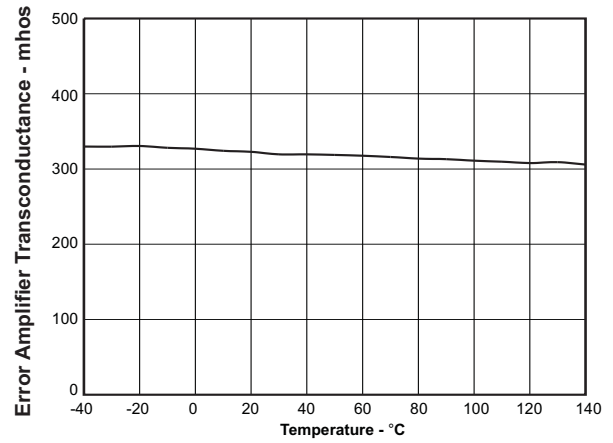

Figure 7.

**FB VOLTAGE
vs
EASY SCALE STEP**

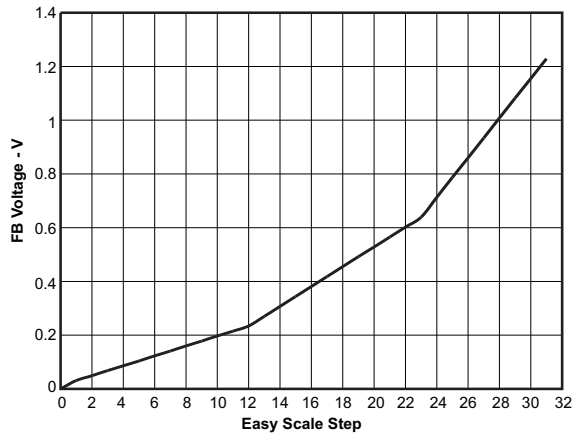

Figure 8.

PWM SWITCHING OPERATION

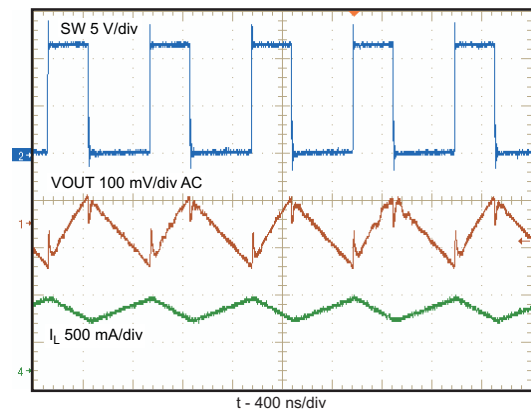

Figure 9.

LOAD TRANSIENT RESPONSE

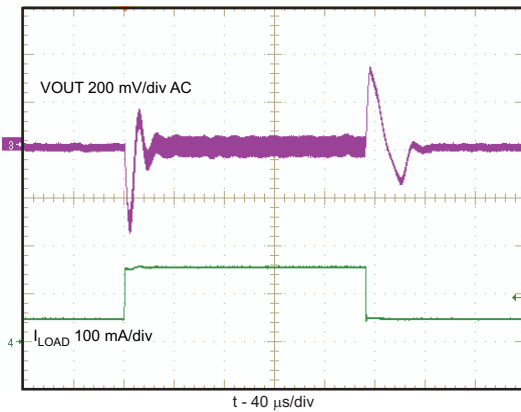

Figure 10.

START-UP

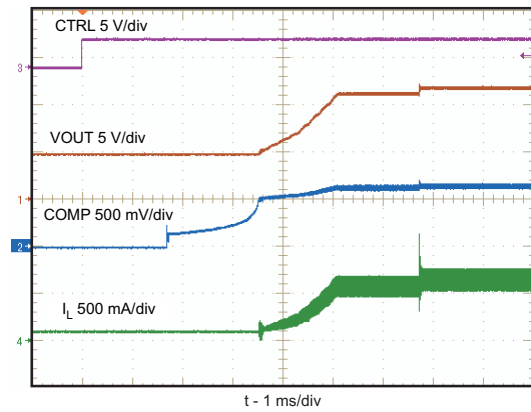
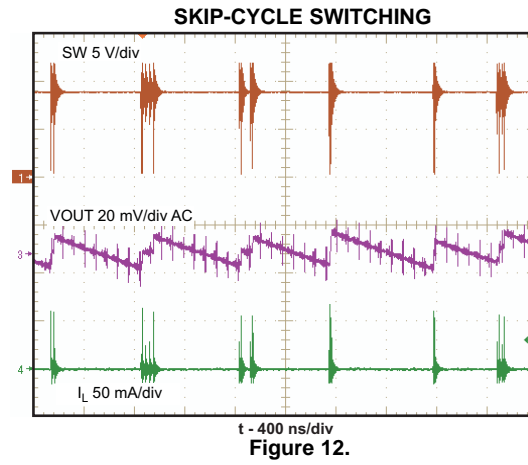

Figure 11.



DETAILED DESCRIPTION

OPERATION

The TPS61170-Q1 integrates a 40-V low side FET for providing output voltages up to 38 V. The device regulates the output with current mode PWM (pulse width modulation) control. The switching frequency of the PWM is fixed at 1.2MHz (typical). The PWM control circuitry turns on the switch at the beginning of each switching cycle. The input voltage is applied across the inductor and stores the energy as the inductor current ramps up. During this portion of the switching cycle, the load current is provided by the output capacitor. When the inductor current rises to the threshold set by the error amplifier output, the power switch turns off and the external Schottky diode is forward biased. The inductor transfers stored energy to replenish the output capacitor and supply the load current. This operation repeats each switching cycle. As shown in the block diagram, the duty cycle of the converter is determined by the PWM control comparator which compares the error amplifier output and the current signal.

A ramp signal from the oscillator is added to the current ramp. This *slope* compensation ramp is necessary to avoid sub-harmonic oscillations that are intrinsic to current mode control at duty cycles higher than 50%. The feedback loop regulates the FB pin to a reference voltage through an error amplifier. The output of the error amplifier must be connected to the COMP pin. An external RC compensation network must be connected to the COMP pin to optimize the feedback loop for stability and transient response.

SOFT START-UP

Soft-start circuitry is integrated into the IC to avoid a high inrush current during start-up. After the device is enabled by a logic high signal on the CTRL pin, the FB pin reference voltage ramps up in 32 steps, with each step taking 213 μ s. This ensures that the output voltage rises slowly to reduce inrush current. Additionally, for the first 5 msec after the COMP voltage ramps, the current limit of the PWM switch is set to half of the normal current limit specification or below 700mA (typical). See the start-up waveform for a typical example, [Figure 11](#).

OVERCURRENT PROTECTION

TPS61170-Q1 has a cycle-by-cycle overcurrent limit feature that turns off the power switch once the inductor current reaches the overcurrent limit. The PWM circuitry resets itself at the beginning of the next switch cycle. During an over-current event, this results in a decrease of output voltage that is directly proportional to load current. The current limit threshold as well as input voltage, output voltage, switching frequency and inductor value determine the maximum available output current. Larger inductance values typically increase the current output capability because of the reduced current ripple. See the *APPLICATION INFORMATION* section for the output current calculation.

UNDERVOLTAGE LOCKOUT (UVLO)

An undervoltage lockout prevents mis-operation of the device at input voltages below 2.2V (typical). When the input voltage is below the undervoltage threshold, the device remains off and the internal switch FET is turned off. The undervoltage lockout threshold is set below minimum operating voltage of 3V to avoid any transient VIN dip triggering the UVLO and causing the device to reset. For the input voltages between UVLO threshold and 3V, the device attempts operation, but the specifications are not ensured.

THERMAL SHUTDOWN

An internal thermal shutdown turns off the device when the typical junction temperature of 160°C is exceeded. The IC restarts when the junction temperature drops by 15°C.

ENABLE AND SHUTDOWN

The TPS61170-Q1 enters shutdown when the CTRL voltage is less than 0.4V for more than 2.5ms. In shutdown, the input supply current for the device is less than 1 μ A (max). The CTRL pin has an internal 800k Ω (typical) pull down resistor to disable the device when the pin is left unconnected.

FEEDBACK REFERENCE PROGRAM MODE SELECTION

The CTRL pin is used for changing the FB pin reference voltage *on-the-fly*. There are two methods to program the reference voltage, PWM signal and 1 wire interface (EasyScale™). The programming mode is selected each time the device is enabled. The default mode is to use the duty cycle of the PWM signal on the CTRL pin to modulate the reference voltage. To enter the 1 wire interface mode, the following digital pattern on the CTRL pin must be recognized by the IC every time the IC starts from the shutdown mode.

1. Pull CTRL pin high to enable the TPS61170-Q1 and to start the 1 wire mode detection window.
2. After the EasyScale detection delay (t_{es_delay} , 100µsec) expires, drive CTRL low for more than the EasyScale detection time (t_{es_detect} , 260µsec).
3. The CTRL pin has to be low for more than EasyScale detection time before the EasyScale detection window (t_{es_win} , 1msec) expires. EasyScale detection window starts from the first CTRL pin low to high transition.

The IC immediately enters the 1 wire mode once the above 3 conditions are met. The EasyScale communication can start before the detection window expires. Once the mode is programmed, it can not be changed without another start up. In other words, the IC must be shutdown by pulling the CTRL low for 2.5ms and restarted in order to exit EasyScale Mode. See the *Mode Detection of Feedback Reference Program* figure (Figure 13) for a graphical explanation.

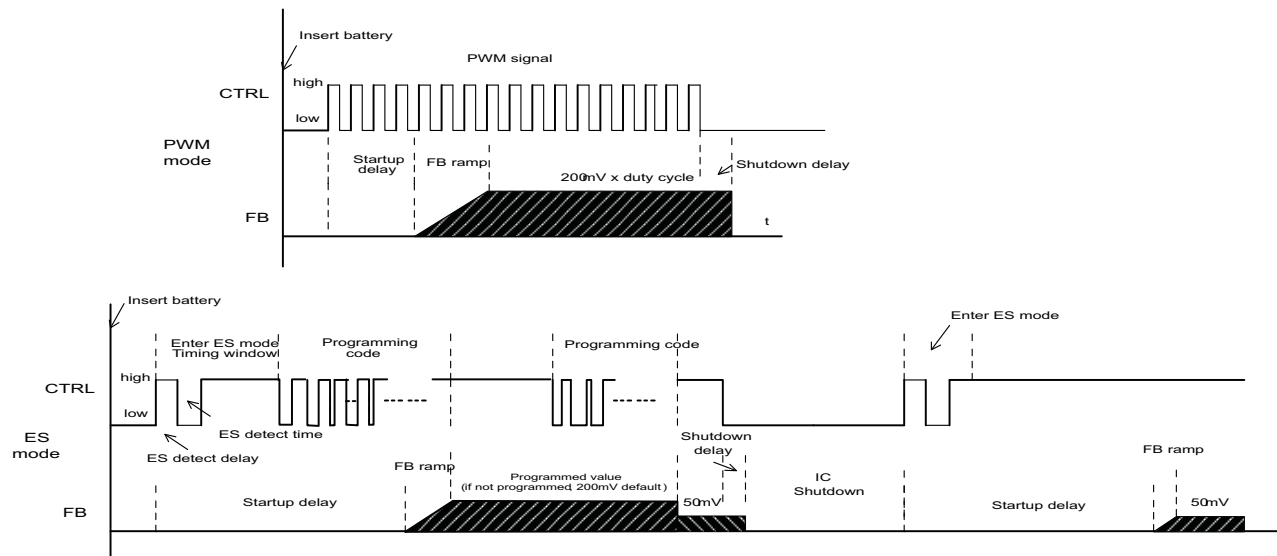

Figure 13. Mode Detection of Feedback Reference Program

PWM PROGRAM MODE

When the CTRL pin is constantly high, the FB voltage is regulated to 1.229V typically. However, the CTRL pin allows a PWM signal to lower this regulation voltage. The relationship between the duty cycle and FB voltage is given in Equation 1:

$$V_{FB} = \text{Duty} \times 1.229 \text{ V} \quad (1)$$

Where:

Duty = duty cycle of the PWM signal

1.229 V = internal reference voltage

As shown in Figure 14, the IC chops up the internal 1.229V reference voltage at the duty cycle of the PWM signal. The pulse signal is then filtered by an internal low pass filter. The output of the filter is connected to the error amplifier as the reference voltage for the FB pin regulation. The regulation voltage is independent of the PWM logic voltage level which often has large variations.

For optimum performance, use the PWM mode in the range of 5kHz to 100kHz. The requirement of minimum frequency comes from the EasyScale detection delay and detection time specification for the mode selection. The device can mistakenly enter 1 wire mode if the PWM signal frequency is less than 5kHz. Because there is an internal fixed ON-time error of 40nS, the FB voltage absolute value will be different than expected when the PWM frequency is above 100kHz. For example, the additional duty cycle of 3.2% due to the ON-time error increases the FB voltage when using an 800kHz PWM signal. A compromise between PWM frequency and FB voltage accuracy extends the frequency range. Adding an external RC filter to the pin serves no purpose.

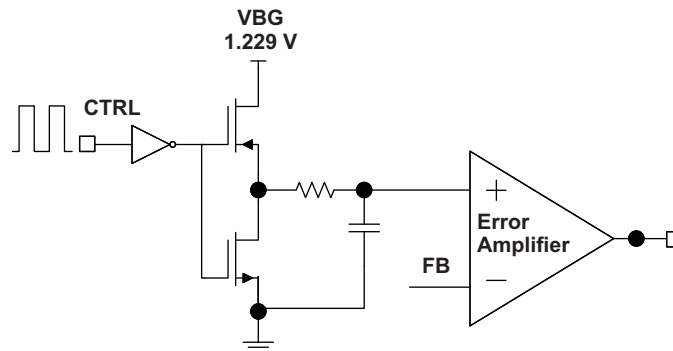

Figure 14. Block Diagram of Programmable FB Voltage Using PWM Signal

1 WIRE PROGRAM MODE

The CTRL pin features a simple digital interface to control the feedback reference voltage. The 1 wire mode can save the processor power and battery life as it does not require a PWM signal all the time, and the processor can enter idle mode if available.

The TPS61170-Q1 adopts the EasyScale™ protocol, which can program the FB voltage to any of the 32 steps with single command. See Table 1 for the FB pin voltage steps. The programmed reference voltage is stored in an internal register. The default value is full scale when the device is first enabled ($V_{FB} = 1.229V$). A power reset clears the register value and reset it to default.

EasyScale™

EasyScale is a simple but very flexible one pin interface to configure the FB voltage. The interface is based on a master-slave structure, where the master is typically a microcontroller or application processor. Figure 15 and Table 1 give an overview of the protocol. The protocol consists of a device specific address byte and a data byte. The device specific address byte is fixed to 72 hex. The data byte consists of five bits for information, two address bits, and the RFA bit. The RFA bit set to high indicates the *Request for Acknowledge* condition. The Acknowledge condition is only applied if the protocol was received correctly. The advantage of EasyScale compared with other on pin interfaces is that its bit detection is in a large extent independent from the bit transmission rate. It can automatically detect bit rates between 1.7kBit/sec and up to 160kBit/sec.

Table 1. Selectable FB Voltage

	FB voltage (mV)	D4	D3	D2	D1	D0
0	0.000	0	0	0	0	0
1	0.031	0	0	0	0	1
2	0.049	0	0	0	1	0
3	0.068	0	0	0	1	1
4	0.086	0	0	1	0	0
5	0.104	0	0	1	0	1
6	0.123	0	0	1	1	0
7	0.141	0	0	1	1	1
8	0.160	0	1	0	0	0
9	0.178	0	1	0	0	1

Table 1. Selectable FB Voltage (continued)

	FB voltage (mV)	D4	D3	D2	D1	D0
10	0.197	0	1	0	1	0
11	0.215	0	1	0	1	1
12	0.234	0	1	1	0	0
13	0.270	0	1	1	0	1
14	0.307	0	1	1	1	0
15	0.344	0	1	1	1	1
16	0.381	1	0	0	0	0
17	0.418	1	0	0	0	1
18	0.455	1	0	0	1	0
19	0.492	1	0	0	1	1
20	0.528	1	0	1	0	0
21	0.565	1	0	1	0	1
22	0.602	1	0	1	1	0
23	0.639	1	0	1	1	1
24	0.713	1	1	0	0	0
25	0.787	1	1	0	0	1
26	0.860	1	1	0	1	0
27	0.934	1	1	0	1	1
28	1.008	1	1	1	0	0
29	1.082	1	1	1	0	1
30	1.155	1	1	1	1	0
31	1.229	1	1	1	1	1

DATA IN

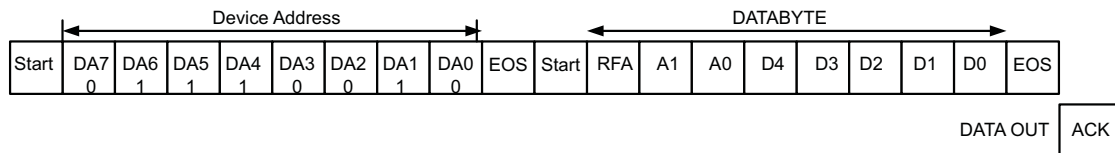

Figure 15. EasyScale™ Protocol Overview

Table 2. EasyScale™ Bit Description

BYTE	BIT NUMBER	NAME	TRANSMISSION DIRECTION	DESCRIPTION
Device Address Byte 72 hex	7	DA7	IN	0 MSB device address
	6	DA6		1
	5	DA5		1
	4	DA4		1
	3	DA3		0
	2	DA2		0
	1	DA1		1
	0	DA0		0 LSB device address

Table 2. EasyScale™ Bit Description (continued)

BYTE	BIT NUMBER	NAME	TRANSMISSION DIRECTION	DESCRIPTION
Data byte	7 (MSB)	RFA	IN	Request for acknowledge. If high, acknowledge is applied by device
	6	A1		0 Address bit 1
	5	A0		0 Address bit 0
	4	D4		Data bit 4
	3	D3		Data bit 3
	2	D2		Data bit 2
	1	D1		Data bit 1
	0 (LSB)	D0		Data bit 0
		ACK	OUT	Acknowledge condition active 0, this condition will only be applied in case RFA bit is set. Open drain output, Line needs to be pulled high by the host with a pullup resistor. This feature can only be used if the master has an open drain output stage. In case of a push pull output stage Acknowledge condition may not be requested!

Easy Scale Timing, without acknowledge RFA = 0

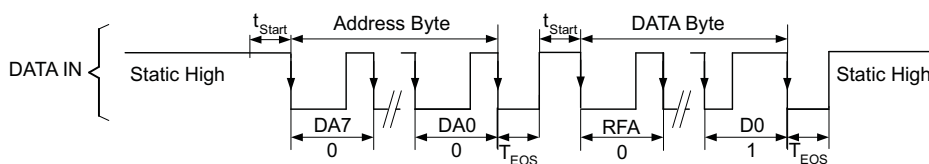

Easy Scale Timing, with acknowledge RFA = 1

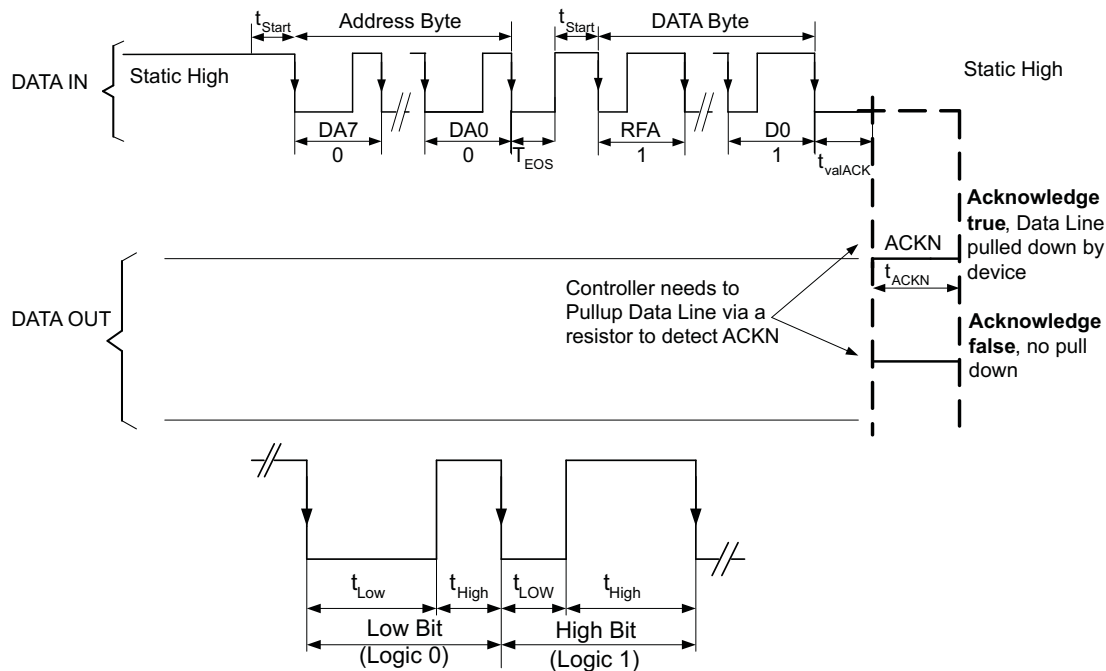

Figure 16. EasyScale™— Bit Coding

All bits are transmitted MSB first and LSB last. Figure 16 shows the protocol without acknowledge request (Bit RFA = 0), Figure 16 with acknowledge (Bit RFA = 1) request. Prior to both bytes, device address byte and data byte, a start condition must be applied. For this, the CTRL pin must be pulled high for at least t_{start} (2µs) before the bit transmission starts with the falling edge. If the CTRL pin is already at high level, no start condition is needed prior to the device address byte. The transmission of each byte is closed with an End of Stream condition for at least t_{EOS} (2µs).

The bit detection is based on a Logic Detection scheme, where the criterion is the relation between t_{LOW} and t_{HIGH} . It can be simplified to:

High Bit: $t_{HIGH} > t_{LOW}$, but with t_{HIGH} at least $2x t_{LOW}$, see [Figure 16](#).

Low Bit: $t_{HIGH} < t_{LOW}$, but with t_{LOW} at least $2x t_{HIGH}$, see [Figure 16](#).

The bit detection starts with a falling edge on the CTRL pin and ends with the next falling edge. Depending on the relation between t_{HIGH} and t_{LOW} , the logic 0 or 1 is detected.

The acknowledge condition is only applied if:

- Acknowledge is requested by a set RFA bit.
- The transmitted device address matches with the device address of the device.
- 16 bits is received correctly.

If the device turns on the internal ACKN-MOSFET and pulls the CTRL pin low for the time t_{ACKN} , which is $512\mu s$ maximum then the Acknowledge condition is valid after an internal delay time t_{valACK} . This means that the internal ACKN-MOSFET is turned on after t_{valACK} , when the last falling edge of the protocol was detected. The master controller keeps the line low in this period. The master device can detect the acknowledge condition with its input by releasing the CTRL pin after t_{valACK} and read back a logic 0. The CTRL pin can be used again after the acknowledge condition ends.

Note that the acknowledge condition may only be requested if the master device has an open drain output. For the push-pull output stage, the use a series resistor in the CTRL line to limit the current to $500\mu A$ is recommended for such cases as:

- an accidentally requested acknowledge, or
- to protect the internal ACKN-MOSFET.

APPLICATION INFORMATION

PROGRAM OUTPUT VOLTAGE

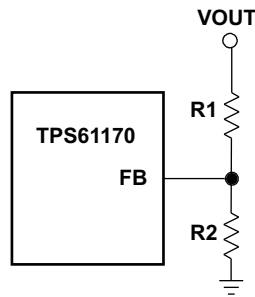

Figure 17. Program Output Voltage

To program the output voltage, select the values of R1 and R2 (See Figure 17) according to Equation 2.

$$V_{out} = 1.229 \text{ V} \times \left(\frac{R1}{R2} + 1 \right) \quad R1 = R2 \times \left(\frac{V_{out}}{1.229 \text{ V}} - 1 \right) \quad (2)$$

Considering the leakage current through the resistor divider and noise decoupling to FB pin, an optimum value for R2 is around 10k. The output voltage tolerance depends on the accuracy of the reference voltage and the tolerance of R1 and R2.

MAXIMUM OUTPUT CURRENT

The overcurrent limit in a boost converter limits the maximum input current, and thus the maximum input power for a given input voltage. The maximum output power is less than the maximum input power due to power conversion losses. Therefore, the current-limit setting, input voltage, output voltage and efficiency can all affect the maximum output current. The current limit clamps the peak inductor current; therefore, the ripple must be subtracted to derive the maximum DC current. The ripple current is a function of the switching frequency, inductor value and duty cycle. The following equations take into account of all the above factors for maximum output current calculation.

$$I_P = \frac{1}{\left[L \times F_s \times \left(\frac{1}{V_{out} + V_f - V_{in}} + \frac{1}{V_{in}} \right) \right]} \quad (3)$$

where:

I_P = inductor peak to peak ripple current

L = inductor value

V_f = Schottky diode forward voltage

F_s = switching frequency

V_{out} = output voltage

$$I_{out_max} = \frac{V_{in} \times (I_{lim} - I_P / 2) \times \eta}{V_{out}} \quad (4)$$

where:

I_{out_max} = Maximum output current of the boost converter

I_{lim} = overcurrent limit

η = efficiency

For instance, when V_{in} is 5 V, V_{out} is 12 V, the inductor is 10 μH , the Schottky forward voltage is 0.2 V; and then the maximum output current is 300 mA in a typical operation.

SWITCH DUTY CYCLE

The maximum switch duty cycle (D) of the TPS61170-Q1 is 90% (min). The duty cycle of a boost converter under continuous conduction mode (CCM) is given by:

$$D = \frac{V_{out} - V_{in}}{V_{out}} \quad (5)$$

For a 5V to 12V application, the duty cycle is 58.3%, and for a 5V to 24V application, the duty cycle is 79.2%. The duty cycle must be lower than the maximum specification of 90% in the application; otherwise, the output voltage can not be regulated.

Once the PWM switch is turned on, the TPS61170-Q1 has minimum ON pulse width. This sets the limit of the minimum duty cycle. When operating at low duty cycles, the TPS61170-Q1 enters pulse-skipping mode. In this mode, the device turns the power switch off for several switching cycles to prevent the output voltage from rising above regulation. This operation typically occurs in light load condition when the PWM operates in discontinuous mode. See the [Figure 12](#).

INDUCTOR SELECTION

The selection of the inductor affects steady state operation as well as transient behavior and loop stability. These factors make it the most important component in power regulator design. There are three important inductor specifications: inductor value, DC resistance (DCR) and saturation current. Considering inductor value alone is not enough.

The inductance value of the inductor determines its ripple current. It is recommended that the peak-to-peak ripple current given by [Equation 3](#) be set to 30–40% of the DC current. Inductance values shown in the Recommended Operating Conditions (ROC) table are recommended for most applications. Inductor DC current can be calculated as

$$I_{in_DC} = \frac{V_{out} \times I_{out}}{V_{in} \times \eta} \quad (6)$$

Inductor values can have $\pm 20\%$ tolerance with no current bias. When the inductor current approaches saturation level, its inductance can decrease 20% to 35% from the 0A value depending on how the inductor vendor defines saturation current. Using an inductor with a smaller inductance value forces discontinuous PWM where the inductor current ramps down to zero before the end of each switching cycle. This reduces the boost converter's maximum output current, causes large input voltage ripple and reduces efficiency. In general, inductors with large inductance and low DCR values provide much more output current and higher conversion efficiency. Inductors with smaller inductance values can give better load transient response. For these reasons, a 10 μ H to 22 μ H inductance value range is recommended. [Table 3](#) lists some recommended inductors for the TPS61170-Q1.

TPS61170-Q1 has built-in slope compensation to avoid sub-harmonic oscillation associated with current mode control. If the inductor value is lower than 10 μ H, the slope compensation may not be adequate, and the loop can become unstable. Therefore, customers need to verify operation in their application if the inductor is different from the recommended values.

Table 3. Recommended Inductors for TPS61170-Q1

PART NUMBER	L (μ H)	DCR MAX (m Ω)	SATURATION CURRENT (A)	SIZE (L \times W \times H mm)	VENDOR
A915_Y-100M	10	90	1.3	5.2 \times 5.2 \times 3.0	TOKO
VLCF5020T-100M1R1-1	10	237	1.1	5 \times 5 \times 2.0	TDK
CDRH4D22/HP	10	144	1.2	5 \times 5 \times 2.4	Sumida
LQH43PN100MR0	10	247	0.84	4.5 \times 3.2 \times 2.0	Murata

SCHOTTKY DIODE SELECTION

The high switching frequency of the TPS61170-Q1 demands a high-speed rectifying switch for optimum efficiency. Ensure that the diode's average and peak current rating exceeds the average output current and peak inductor current. In addition, the diode's reverse breakdown voltage must exceed the switch FET rating voltage of 40V. So, the ONSemiconductor MBR0540 is recommended for TPS61170-Q1. However, Schottky diodes with lower rated voltages can be used for lower output voltages to save the solution size and cost. For example, a converter providing a 12V output with 20V diode is a good choice.

COMPENSATION CAPACITOR SELECTION

The TPS61170-Q1 has an external compensation, COMP pin, which allows the loop response to be optimized for each application. The COMP pin is the output of the internal error amplifier. An external resistor R3 and ceramic capacitor C3 are connected to COMP pin to provide a pole and a zero. This pole and zero, along with the inherent pole of a current mode control boost converter, determine the close loop frequency response. This is important to a converter stability and transient response.

The following equations summarize the poles, zeros and DC gain of a TPS61170-Q1 boost converter with ceramic output capacitor (C2), as shown in the block diagram. They include the dominant pole (f_{P1}), the output pole (f_{P2}) of a boost converter, the right-half-plane zero (f_{RHPZ}) of a boost converter, the zero (f_z) generated by R3 and C3, and the DC gain (A).

$$f_{P1} = \frac{1}{2\pi \times 6 \text{ M}\Omega \times C3} \quad (7)$$

$$f_{P2} = \frac{2}{2\pi \times R_{out} \times C2} \quad (8)$$

$$f_{RHPZ} = \frac{R_{out}}{2\pi \times L} \times \left(\frac{V_{in}}{V_{out}} \right)^2 \quad (9)$$

$$f_z = \frac{1}{2\pi \times R3 \times C3} \quad (10)$$

$$A = \frac{1.229}{V_{out}} \times G_{ea} \times 6 \text{ M}\Omega \times \frac{V_{in}}{V_{out} \times R_{sense}} \times R_{out} \times \frac{1}{2} \quad (11)$$

where R_{out} is the load resistance, G_{ea} is the error amplifier transconductance located in the ELECTRICAL CHARACTERISTICS table, R_{sense} (100m Ω typical) is a sense resistor in the current control loop. These equations help generate a simple bode plot for TPS61170-Q1 loop analysis.

Increasing R3 or reducing C3 increases the close loop bandwidth which improves the transient response. Adjusting R3 and C3 in opposite directions increase the phase, and help loop stability. For many of the applications, the recommended value of 10k and 680pF makes an ideal compromise between transient response and loop stability. To optimize the compensation, use C3 in the range of 100pF to 10nF, and R3 of 10k. See the TI application report [SLVA319](#) for thorough analysis and description of the boost converter small signal model and compensation design.

INPUT AND OUTPUT CAPACITOR SELECTION

The output capacitor is mainly selected to meet the requirements for the output ripple and loop stability. The ripple voltage is related to the capacitor's capacitance and its equivalent series resistance (ESR). Assuming a capacitor with zero ESR, the minimum capacitance needed for a given ripple can be calculated using [Equation 12](#).

$$C_{out} = \frac{(V_{out} - V_{in}) I_{out}}{V_{out} \times F_s \times V_{ripple}} \quad (12)$$

Where, V_{ripple} = peak-to-peak output ripple. The additional output ripple component caused by ESR is calculated using:

$$V_{ripple_ESR} = I_{out} \times R_{ESR} \quad (13)$$

Due to its low ESR, V_{ripple_ESR} can be neglected for ceramic capacitors, but must be considered if tantalum or electrolytic capacitors are used.

Care must be taken when evaluating a ceramic capacitor's derating under dc bias, aging and AC signal. For example, larger form factor capacitors (in 1206 size) have a resonant frequencies in the range of the switching frequency. So, the effective capacitance is significantly lower. The DC bias can also significantly reduce capacitance. Ceramic capacitors can lose as much as 50% of its capacitance at its rated voltage. Therefore, choose a ceramic capacitor with a voltage rating at least 1.5X its expected dc bias voltage.

The capacitor in the range of 1 μ F to 4.7 μ F is recommended for input side. The output typically requires a capacitor in the range of 1 μ F to 10 μ F. The output capacitor affects the loop stability of the boost regulator. If the output capacitor is below the range, the boost regulator can potentially become unstable.

The popular vendors for high value ceramic capacitors are:

TDK (<http://www.component.tdk.com/components.php>)

Murata (<http://www.murata.com/cap/index.html>)

LAYOUT CONSIDERATIONS

As for all switching power supplies, especially those switching at high frequencies and/or providing high currents, layout is an important design step. If layout is not carefully done, the regulator could suffer from instability as well as noise problems. To maximize efficiency, switch rise and fall times should be as short as possible. To reduce radiation of high frequency switching noise and harmonics, proper layout of the high frequency switching path is essential. Minimize the length and area of all traces connected to the SW pin and always use a ground plane under the switching regulator to minimize interplane coupling. The high current path including the switch, Schottky diode, and output capacitor, contains nanosecond rise and fall times and should be kept as short as possible. The input capacitor needs not only to be close to the VIN pin, but also to the GND pin in order to reduce the IC supply ripple. Figure 18 shows a sample layout

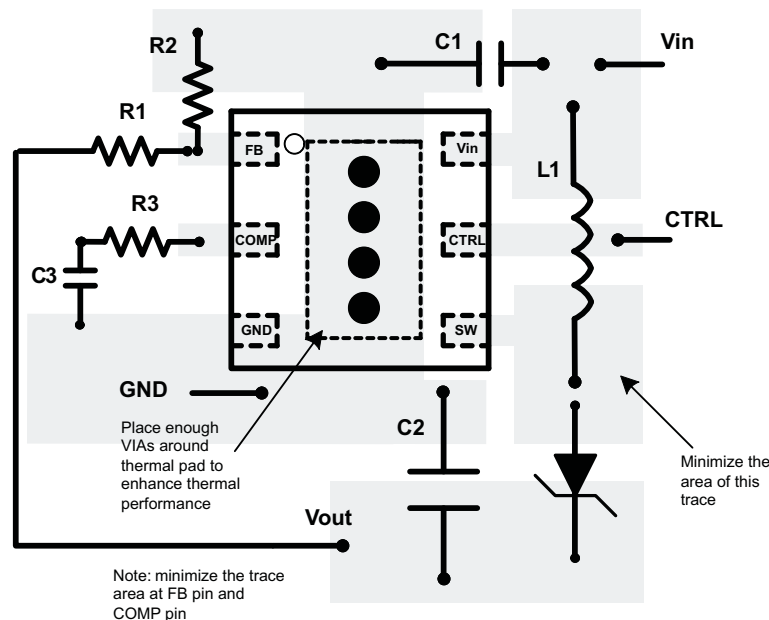

Figure 18. PCB Layout Recommendation

THERMAL CONSIDERATIONS

The maximum IC junction temperature should be restricted to 125°C under normal operating conditions. This restriction limits the power dissipation of the TPS61170-Q1. Calculate the maximum allowable dissipation, $P_{D(max)}$, and keep the actual dissipation less than or equal to $P_{D(max)}$. The maximum-power-dissipation limit is determined using Equation 14:

$$P_{D(max)} = \frac{125^{\circ}\text{C} - T_A}{R_{\theta JA}} \quad (14)$$

where, T_A is the maximum ambient temperature for the application. $R_{\theta JA}$ is the thermal resistance junction-to-ambient given in Power Dissipation Table.

The TPS61170-Q1 comes in a thermally enhanced QFN package. This package includes a thermal pad that improves the thermal capabilities of the package. The $R_{\theta JA}$ of the QFN package greatly depends on the PCB layout and thermal pad connection. The thermal pad must be soldered to the analog ground on the PCB. Using thermal vias underneath the thermal pad as illustrated in the layout example. Also see the *QFN/SON PCB Attachment* application report (SLUA271).

ADDITIONAL TYPICAL APPLICATIONS

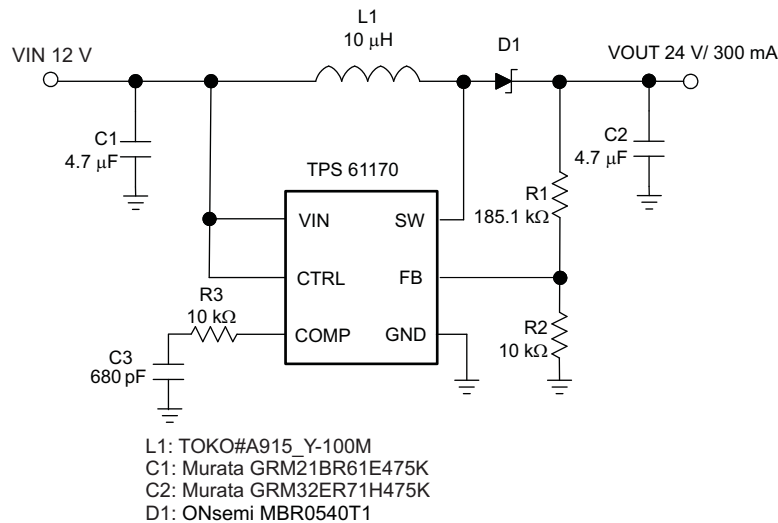

Figure 19. 12V to 24V DCDC Power Conversion

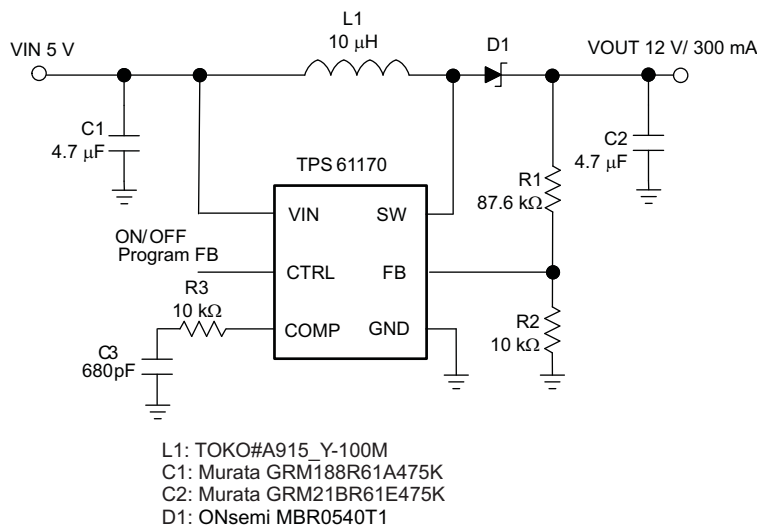

Figure 20. 5V to 12V DCDC Power Conversion With Programmable Feedback Reference Voltage

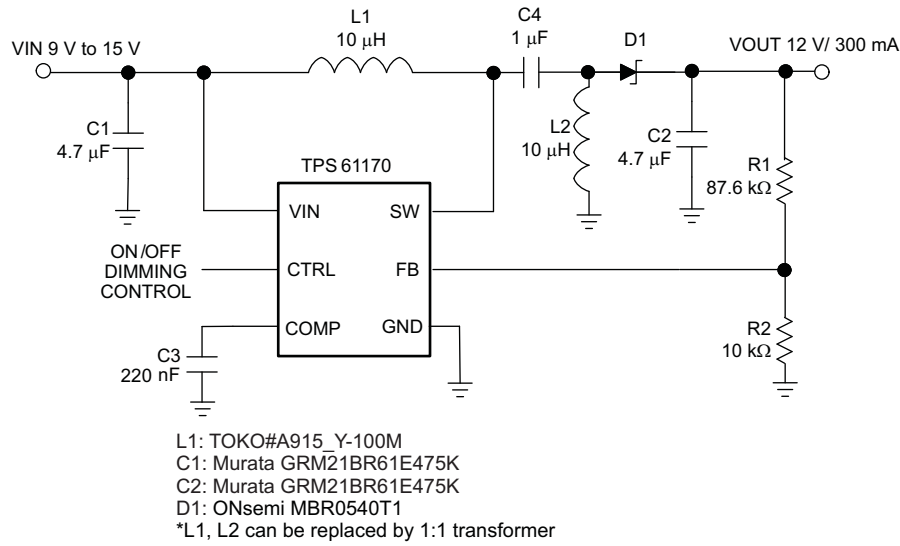

Figure 21. 12V SEPIC (Buck-Boost) Converter

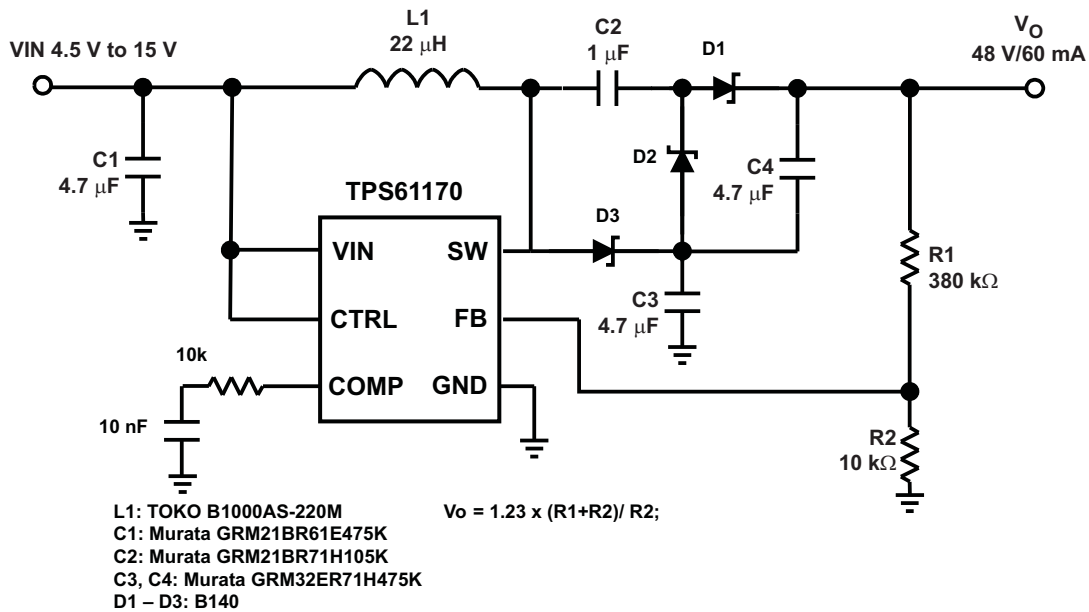

Figure 22. 48V Phantom Power Application Circuit

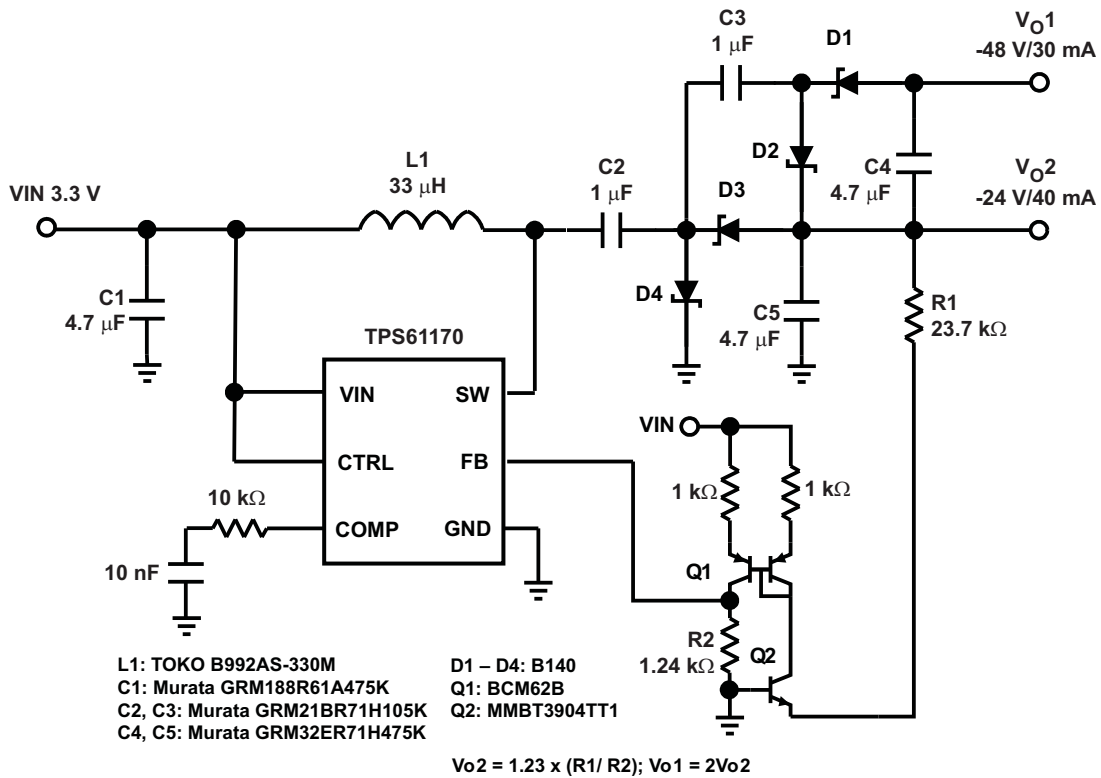

Figure 23. –24V / –48V Buck-Boost Converter from 3.3-V Input

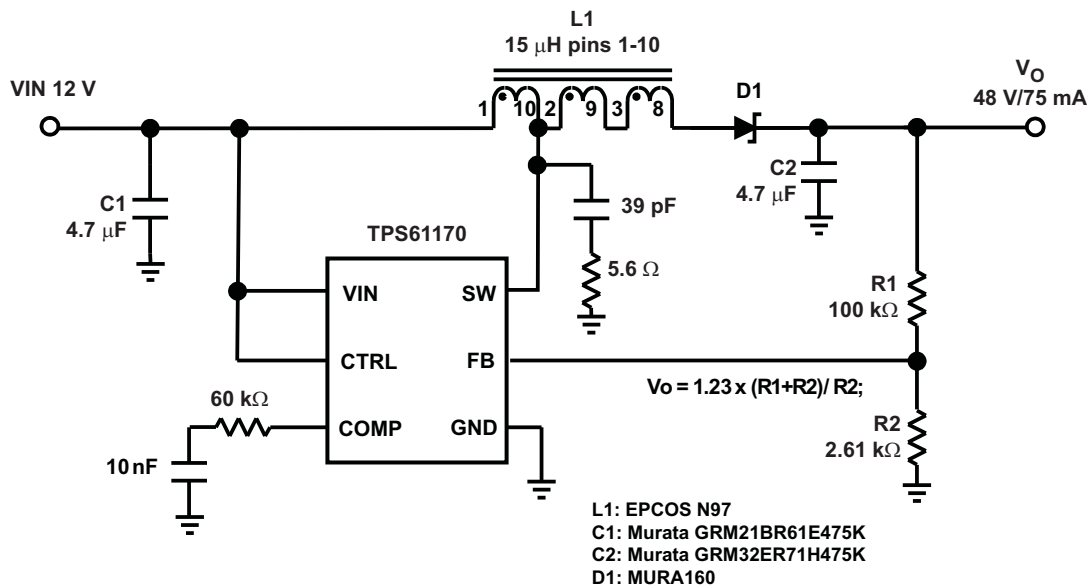

Figure 24. 12V to 48V Flyback Topology

PACKAGING INFORMATION

Orderable Device	Status (1)	Package Type	Package Drawing	Pins	Package Qty	Eco Plan (2)	Lead/Ball Finish	MSL Peak Temp (3)	Op Temp (°C)	Top-Side Markings (4)	Samples
TPS61170QDRVRQ1	ACTIVE	SON	DRV	6	3000	Green (RoHS & no Sb/Br)	CU NIPDAU	Level-2-260C-1 YEAR	-40 to 125	RAP	Samples

(1) The marketing status values are defined as follows:

ACTIVE: Product device recommended for new designs.

LIFEBUY: TI has announced that the device will be discontinued, and a lifetime-buy period is in effect.

NRND: Not recommended for new designs. Device is in production to support existing customers, but TI does not recommend using this part in a new design.

PREVIEW: Device has been announced but is not in production. Samples may or may not be available.

OBSOLETE: TI has discontinued the production of the device.

(2) Eco Plan - The planned eco-friendly classification: Pb-Free (RoHS), Pb-Free (RoHS Exempt), or Green (RoHS & no Sb/Br) - please check <http://www.ti.com/productcontent> for the latest availability information and additional product content details.

TBD: The Pb-Free/Green conversion plan has not been defined.

Pb-Free (RoHS): TI's terms "Lead-Free" or "Pb-Free" mean semiconductor products that are compatible with the current RoHS requirements for all 6 substances, including the requirement that lead not exceed 0.1% by weight in homogeneous materials. Where designed to be soldered at high temperatures, TI Pb-Free products are suitable for use in specified lead-free processes.

Pb-Free (RoHS Exempt): This component has a RoHS exemption for either 1) lead-based flip-chip solder bumps used between the die and package, or 2) lead-based die adhesive used between the die and leadframe. The component is otherwise considered Pb-Free (RoHS compatible) as defined above.

Green (RoHS & no Sb/Br): TI defines "Green" to mean Pb-Free (RoHS compatible), and free of Bromine (Br) and Antimony (Sb) based flame retardants (Br or Sb do not exceed 0.1% by weight in homogeneous material)

(3) MSL, Peak Temp. -- The Moisture Sensitivity Level rating according to the JEDEC industry standard classifications, and peak solder temperature.

(4) Multiple Top-Side Markings will be inside parentheses. Only one Top-Side Marking contained in parentheses and separated by a "~" will appear on a device. If a line is indented then it is a continuation of the previous line and the two combined represent the entire Top-Side Marking for that device.

Important Information and Disclaimer: The information provided on this page represents TI's knowledge and belief as of the date that it is provided. TI bases its knowledge and belief on information provided by third parties, and makes no representation or warranty as to the accuracy of such information. Efforts are underway to better integrate information from third parties. TI has taken and continues to take reasonable steps to provide representative and accurate information but may not have conducted destructive testing or chemical analysis on incoming materials and chemicals. TI and TI suppliers consider certain information to be proprietary, and thus CAS numbers and other limited information may not be available for release.

In no event shall TI's liability arising out of such information exceed the total purchase price of the TI part(s) at issue in this document sold by TI to Customer on an annual basis.

OTHER QUALIFIED VERSIONS OF TPS61170-Q1 :

- Catalog: [TPS61170](#)

NOTE: Qualified Version Definitions:

- Catalog - TI's standard catalog product

TAPE AND REEL INFORMATION
REEL DIMENSIONS

TAPE DIMENSIONS

A0	Dimension designed to accommodate the component width
B0	Dimension designed to accommodate the component length
K0	Dimension designed to accommodate the component thickness
W	Overall width of the carrier tape
P1	Pitch between successive cavity centers

TAPE AND REEL INFORMATION

*All dimensions are nominal

Device	Package Type	Package Drawing	Pins	SPQ	Reel Diameter (mm)	Reel Width W1 (mm)	A0 (mm)	B0 (mm)	K0 (mm)	P1 (mm)	W (mm)	Pin1 Quadrant
TPS61170QDRVRQ1	SON	DRV	6	3000	180.0	8.4	2.3	2.3	1.15	4.0	8.0	Q2

TAPE AND REEL BOX DIMENSIONS



*All dimensions are nominal

Device	Package Type	Package Drawing	Pins	SPQ	Length (mm)	Width (mm)	Height (mm)
TPS61170QDRVRQ1	SON	DRV	6	3000	210.0	185.0	35.0

MECHANICAL DATA

DRV (S-PWSON-N6)

PLASTIC SMALL OUTLINE NO-LEAD

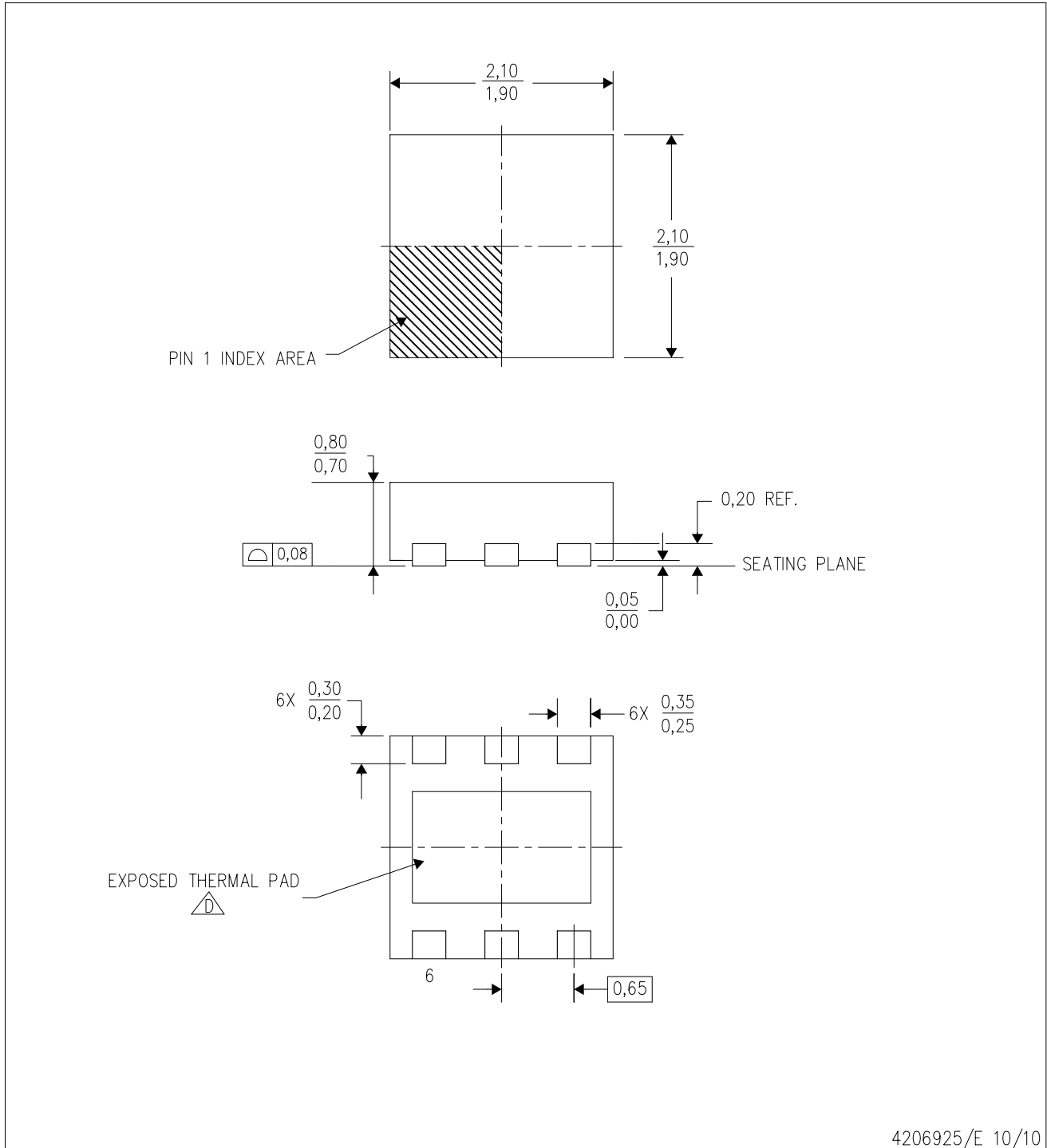

4206925/E 10/10

- NOTES:
- All linear dimensions are in millimeters. Dimensioning and tolerancing per ASME Y14.5M-1994.
 - This drawing is subject to change without notice.
 - Small Outline No-Lead (SON) package configuration.
- (D) The package thermal pad must be soldered to the board for thermal and mechanical performance. See the Product Data Sheet for details regarding the exposed thermal pad dimensions.

THERMAL PAD MECHANICAL DATA

DRV (S-PWSON-N6)

PLASTIC SMALL OUTLINE NO-LEAD

THERMAL INFORMATION

This package incorporates an exposed thermal pad that is designed to be attached directly to an external heatsink. The thermal pad must be soldered directly to the printed circuit board (PCB). After soldering, the PCB can be used as a heatsink. In addition, through the use of thermal vias, the thermal pad can be attached directly to the appropriate copper plane shown in the electrical schematic for the device, or alternatively, can be attached to a special heatsink structure designed into the PCB. This design optimizes the heat transfer from the integrated circuit (IC).

For information on the Quad Flatpack No-Lead (QFN) package and its advantages, refer to Application Report, QFN/SON PCB Attachment, Texas Instruments Literature No. SLUA271. This document is available at www.ti.com.

The exposed thermal pad dimensions for this package are shown in the following illustration.

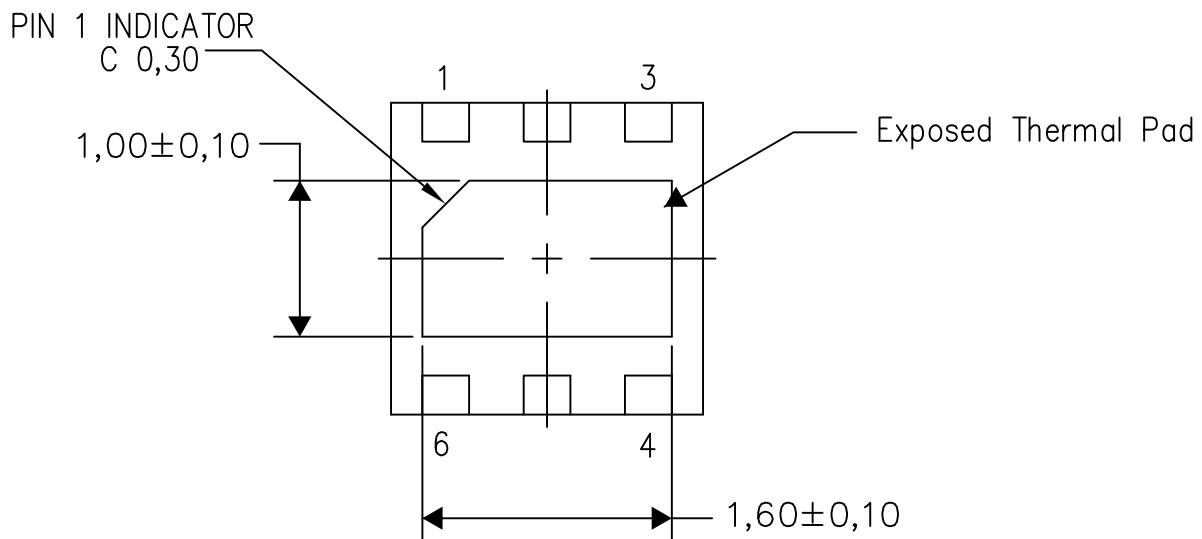

Bottom View

Exposed Thermal Pad Dimensions

4206926/N 03/13

NOTE: All linear dimensions are in millimeters

DRV (S-PWSON-N6)

PLASTIC SMALL OUTLINE NO-LEAD

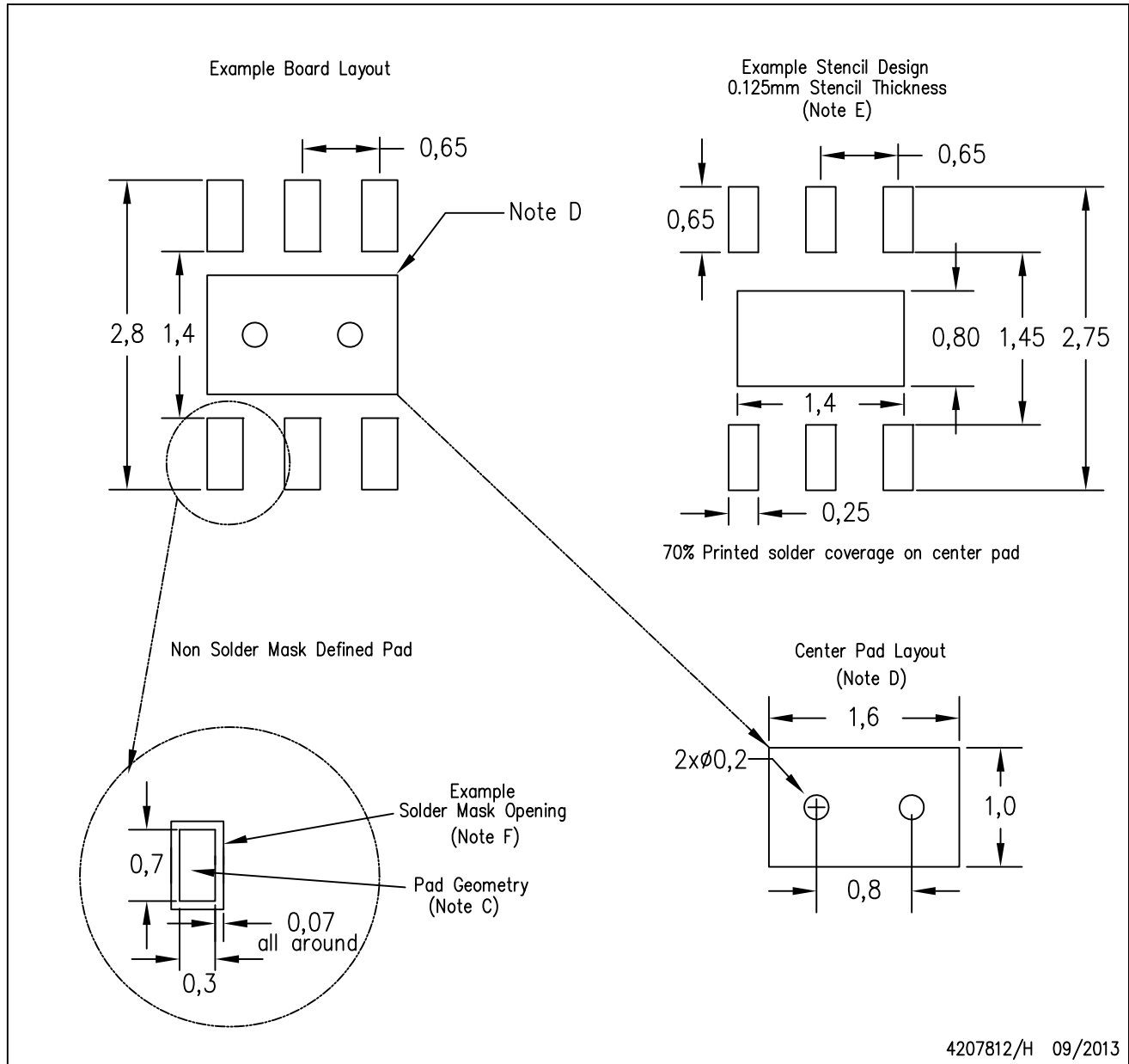

- NOTES:
- All linear dimensions are in millimeters.
 - This drawing is subject to change without notice.
 - Publication IPC-7351 is recommended for alternate designs.
 - This package is designed to be soldered to a thermal pad on the board. Refer to Application Note, QFN/SON PCB Attachment, Texas Instruments Literature No. SLUA271, and also the Product Data Sheets for specific thermal information, via requirements, and recommended board layout. These documents are available at www.ti.com <<http://www.ti.com>>.
 - Laser cutting apertures with trapezoidal walls and also rounding corners will offer better paste release. Customers should contact their board assembly site for stencil design recommendations. Refer to IPC 7525 for stencil design considerations.
 - Customers should contact their board fabrication site for solder mask tolerances.

IMPORTANT NOTICE

Texas Instruments Incorporated and its subsidiaries (TI) reserve the right to make corrections, enhancements, improvements and other changes to its semiconductor products and services per JESD46, latest issue, and to discontinue any product or service per JESD48, latest issue. Buyers should obtain the latest relevant information before placing orders and should verify that such information is current and complete. All semiconductor products (also referred to herein as "components") are sold subject to TI's terms and conditions of sale supplied at the time of order acknowledgment.

TI warrants performance of its components to the specifications applicable at the time of sale, in accordance with the warranty in TI's terms and conditions of sale of semiconductor products. Testing and other quality control techniques are used to the extent TI deems necessary to support this warranty. Except where mandated by applicable law, testing of all parameters of each component is not necessarily performed.

TI assumes no liability for applications assistance or the design of Buyers' products. Buyers are responsible for their products and applications using TI components. To minimize the risks associated with Buyers' products and applications, Buyers should provide adequate design and operating safeguards.

TI does not warrant or represent that any license, either express or implied, is granted under any patent right, copyright, mask work right, or other intellectual property right relating to any combination, machine, or process in which TI components or services are used. Information published by TI regarding third-party products or services does not constitute a license to use such products or services or a warranty or endorsement thereof. Use of such information may require a license from a third party under the patents or other intellectual property of the third party, or a license from TI under the patents or other intellectual property of TI.

Reproduction of significant portions of TI information in TI data books or data sheets is permissible only if reproduction is without alteration and is accompanied by all associated warranties, conditions, limitations, and notices. TI is not responsible or liable for such altered documentation. Information of third parties may be subject to additional restrictions.

Resale of TI components or services with statements different from or beyond the parameters stated by TI for that component or service voids all express and any implied warranties for the associated TI component or service and is an unfair and deceptive business practice. TI is not responsible or liable for any such statements.

Buyer acknowledges and agrees that it is solely responsible for compliance with all legal, regulatory and safety-related requirements concerning its products, and any use of TI components in its applications, notwithstanding any applications-related information or support that may be provided by TI. Buyer represents and agrees that it has all the necessary expertise to create and implement safeguards which anticipate dangerous consequences of failures, monitor failures and their consequences, lessen the likelihood of failures that might cause harm and take appropriate remedial actions. Buyer will fully indemnify TI and its representatives against any damages arising out of the use of any TI components in safety-critical applications.

In some cases, TI components may be promoted specifically to facilitate safety-related applications. With such components, TI's goal is to help enable customers to design and create their own end-product solutions that meet applicable functional safety standards and requirements. Nonetheless, such components are subject to these terms.

No TI components are authorized for use in FDA Class III (or similar life-critical medical equipment) unless authorized officers of the parties have executed a special agreement specifically governing such use.

Only those TI components which TI has specifically designated as military grade or "enhanced plastic" are designed and intended for use in military/aerospace applications or environments. Buyer acknowledges and agrees that any military or aerospace use of TI components which have **not** been so designated is solely at the Buyer's risk, and that Buyer is solely responsible for compliance with all legal and regulatory requirements in connection with such use.

TI has specifically designated certain components as meeting ISO/TS16949 requirements, mainly for automotive use. In any case of use of non-designated products, TI will not be responsible for any failure to meet ISO/TS16949.

Products

Audio	www.ti.com/audio
Amplifiers	amplifier.ti.com
Data Converters	dataconverter.ti.com
DLP® Products	www.dlp.com
DSP	dsp.ti.com
Clocks and Timers	www.ti.com/clocks
Interface	interface.ti.com
Logic	logic.ti.com
Power Mgmt	power.ti.com
Microcontrollers	microcontroller.ti.com
RFID	www.ti-rfid.com
OMAP Applications Processors	www.ti.com/omap
Wireless Connectivity	www.ti.com/wirelessconnectivity

Applications

Automotive and Transportation	www.ti.com/automotive
Communications and Telecom	www.ti.com/communications
Computers and Peripherals	www.ti.com/computers
Consumer Electronics	www.ti.com/consumer-apps
Energy and Lighting	www.ti.com/energy
Industrial	www.ti.com/industrial
Medical	www.ti.com/medical
Security	www.ti.com/security
Space, Avionics and Defense	www.ti.com/space-avionics-defense
Video and Imaging	www.ti.com/video

TI E2E Community

e2e.ti.com

AMEYA360

Components Supply Platform

Authorized Distribution Brand :



Website :

Welcome to visit www.ameya360.com

Contact Us :

➤ Address :

401 Building No.5, JiuGe Business Center, Lane 2301, Yishan Rd
Minhang District, Shanghai , China

➤ Sales :

Direct +86 (21) 6401-6692

Email amall@ameya360.com

QQ 800077892

Skype [ameyasales1](#) [ameyasales2](#)

➤ Customer Service :

Email service@ameya360.com

➤ Partnership :

Tel +86 (21) 64016692-8333

Email mkt@ameya360.com