

QUAD LOW SIDE DRIVER

- WIDE INPUT VOLTAGE RANGE -24V UP TO +45V
- WIDE OPERATING SUPPLY VOLTAGE RANGE FROM 4.5V UP TO 32V.
- REVERSE BIASING PROTECTED ($V_S = -24V$)
- VERY LOW STANDBY QUIESCENT CURRENT $< 2\mu A$
- PROGRAMMABLE SIGNAL TRANSFER POLARITY
- TTL AND CMOS COMPATIBLE INPUTS
- DEFINED OUTPUT OFF STATE OFF FOR OPEN INPUTS
- FOUR OPEN DRAIN DMOS OUTPUTS, WITH $R_{Dson} = 1.5 \Omega$ at $25^\circ C$ and $V_S > 6V$
- OUTPUT CURRENT LIMITATION
- CONTROLLED OUTPUT SLOPE FOR LOW EMI
- OVERTEMPERATURE SHUT-DOWN
- INTEGRATED OUTPUT CLAMPING FOR FAST INDUCTIVE RECIRCULATION $V_{FB} > 45V$
- STATUS MONITORING FOR
 - OVERTEMPERATURE

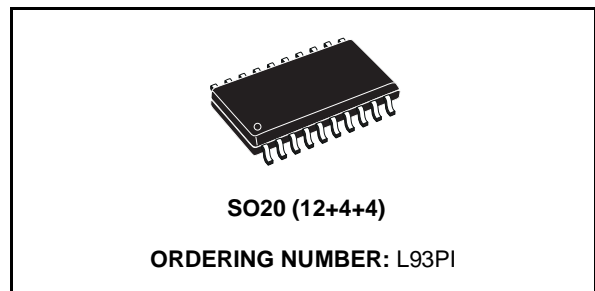

- DISCONNECTED GROUND OR SUPPLY VOLTAGE
- ESD: ALL PINS ARE GUARANTEED TILL 2kV HUMAN BODY MODEL

DESCRIPTION

The L93PI is a monolithic integrated quad low side driver realized in advanced Multipower-BCD technology. It is intended to drive lines, lamps or relays in automotive or industrial applications.

BLOCK DIAGRAM

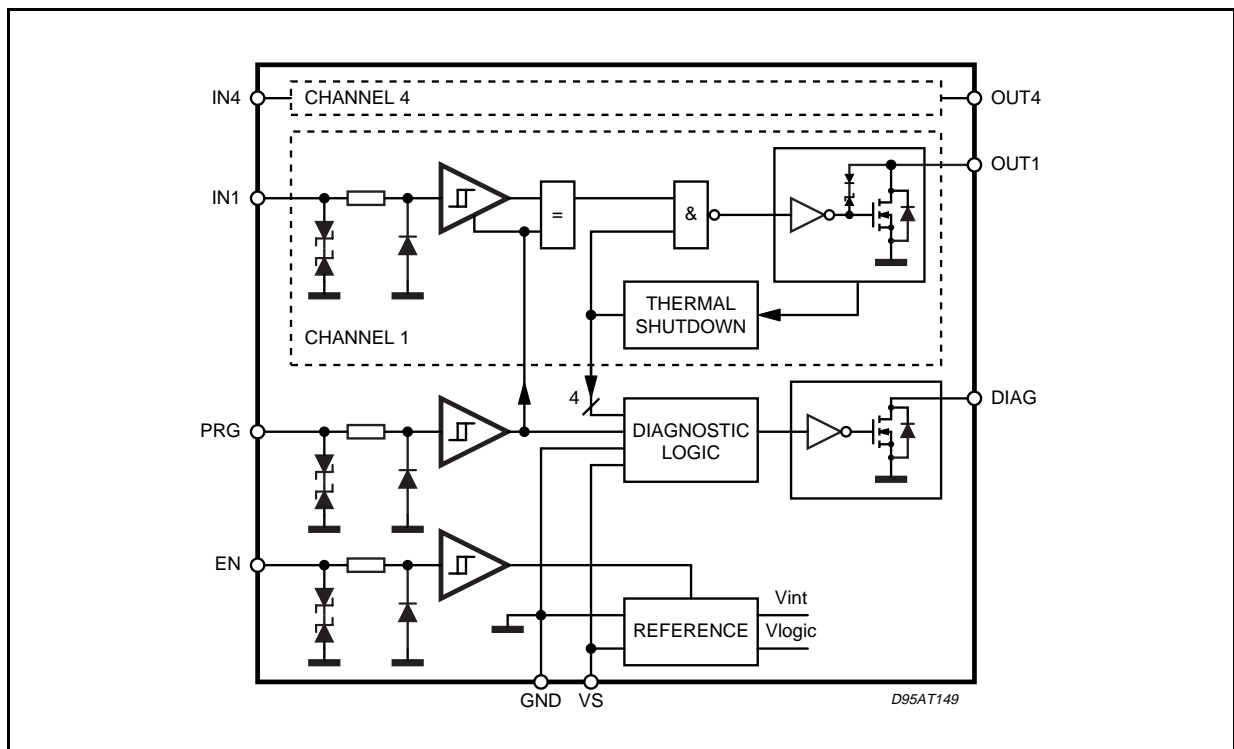

L93PI

ABSOLUTE MAXIMUM RATINGS (no damage or latch)

Symbol	Parameter	Value	Unit
V_S	Supply voltage	-24 to 45	V
Pin voltages			
V_{IN}	Input, enable, program	-24 to 45	V
V_{OUT}	Output	-0.3 to 45	V
V_{DIAG}	Diagnostic output	-0.3 to 45	V
E_X	Max. Energy During Flyback	2	mJ

PIN CONNECTION (Top view)

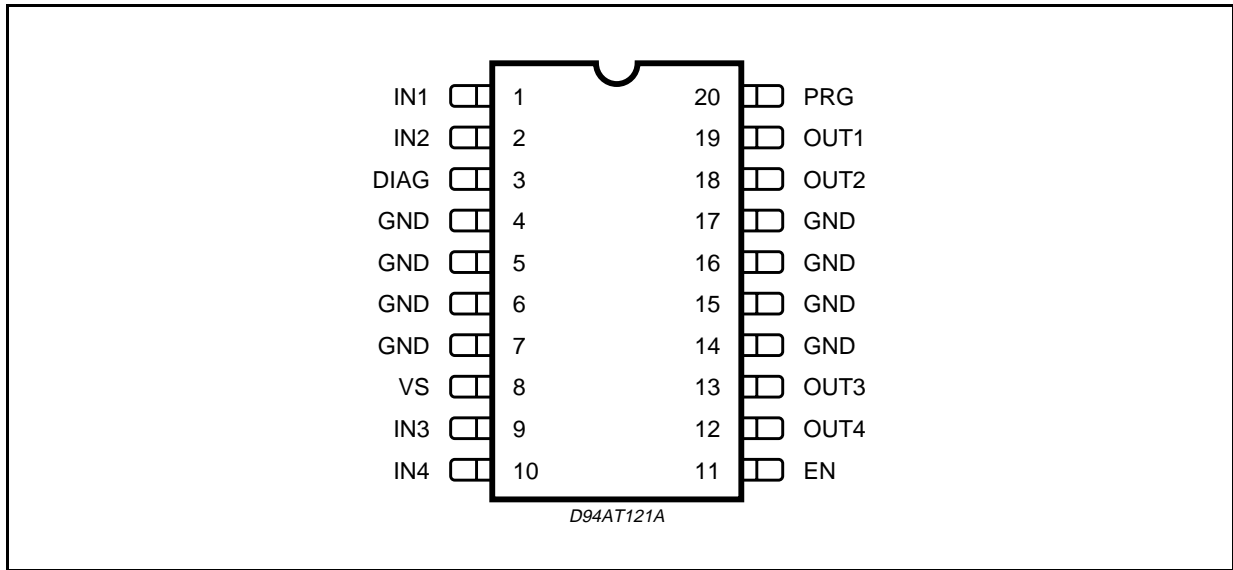

PIN DESCRIPTION

No	Pin Name	Function
8	VS	SUPPLY VOLTAGE
4,5,6,7,14, 15,16,17	GND	GROUND
11	EN	ENABLE
20	PRG	PROGRAM
3	DIAG	DIAGNOSTIC
1	IN1	INPUT 1
2	IN2	INPUT 2
9	IN3	INPUT 3
10	IN4	INPUT 4
19	OUT 1	OUTPUT 1
18	OUT 2	OUTPUT 2
13	OUT 3	OUTPUT 3
12	OUT 4	OUTPUT 4
–	NC	NOT CONNECTED

THERMAL DATA

Symbol	Parameter	SO20 (2)	SO(12+4+4) (1)	Unit
$R_{th(j-pins)}$	Thermal resistance junction to pin	–	14 (Typ.)	°C/W
$R_{th(j-amb)}$	Thermal resistance junction to ambient mounted on SMPCB2 board	77 to 97	–	°C/W
T_{jMon}	Temperature-monitoring Switch-off-level Switch-on-level		160 to 190 140 to 170	°C °C

(1) See SGS-THOMSON Microelectronics databook: "Thermal Management in Surface Mount Technology"

(2) See SGS-THOMSON Microelectronics databook: "Thermal characteristics of SO20"

OPERATING CONDITIONS (The electrical characteristics are valid within the below defined operating ranges, unless otherwise specified. The function will be guaranteed by design until T_{jMON} switch-OFF-level.

Symbol	Parameter	Value	Unit
V_S	Supply Voltage	4.5 to 40	V
V_{IN}	Input pin voltage	-24 to 10	V
V_{EN}	Enable pin voltage	-24 to 45	V
V_{OUT}, V_D	Output pin voltage	-0.3 to 45	V
T_j	Junction temperature	-40 to 150	°C

ELECTRICAL CHARACTERISTICS (Refer to the test circuit, unless otherwise specified.)

Symbol	Parameter	Test Condition	Min.	Typ.	Max.	Unit
I_Q	Quiescent current	$-0.3V \leq V_{EN} \leq 0.5V$; $V_S = 14V$; $T_j = 85^\circ C$		<2	10	μA
		EN = high; $V_S \leq 14V$		1.5	2	mA
Inputs IN1 - IN4, PRG						
V_{INlow}	Input voltage LOW		-24		2.0	V
V_{INhigh}	Input voltage HIGH		2.8		45	V
I_{IN}	Input current	$-24V \leq V_i \leq 10V$	-10		15	μA
Enable Input EN						
V_{ENlow}	Input voltage LOW		-24		1	V
V_{ENhigh}	Input voltage HIGH		3.2		VS	V
R_{EN}	Input impedance	$-24V < V_i < 2.5V$	10			K Ω
I_{EN}	Input current	$2.5V \leq V_i \leq 25V$		20	50	μA
Outputs OUT1-OUT4						
R_{DSon}	Output ON-resistor to ground	$V_S \geq 6V$, $I_O = 0.3A$ $T_j = 25^\circ C$ $T_j = 125^\circ C$		1.7	2.3 3.5	Ω Ω
I_{OLeak}	Leakage current	$V_O = V_S = 14V$; $T_j = 85^\circ C$		≤ 1	5	μA
V_{OClamp}	Output voltage during clamping	time < 200 μs ; $10mA \leq I_O \leq 0.3A$	45	52	60	V
I_{OSC}	Short-circuit current		400	700	1200	mA
C_O	Internal output capacities	$V_O \geq 4.5V$			100	pF
Diagnostic output DIAG						
V_{Dlow}	Output voltage LOW	$I_{DL} \leq 1mA$		0.3	0.5	V
I_{Dmax}	Max. Output current	Internal current limitation	1	5	15	mA
I_{Dleak}	Leakage current	$V_S = 14V$; $T_j = 85^\circ C$		≤ 0.1	1	μA

ELECTRICAL CHARACTERISTICS (Continued)

Symbol	Parameter	Test conditions	Min.	Typ.	Max.	Unit
Timing (see Fig. 1)						
$t_{d,on}$	On delay time	$V_S = 14V, C_{ext} = 0pF$ $10mA \leq I_o \leq 200mA$		2.5	3.5	μs
$t_{d,off}$	Off delay time			3	4.5	μs
t_{set}	Enable settling time				10	μs
$t_{d,DIAG}$	On or Off diagnostic delay time				10	μs
S_{out}	Output slopes		2.5	9	16	$V/\mu s$

Figure 1

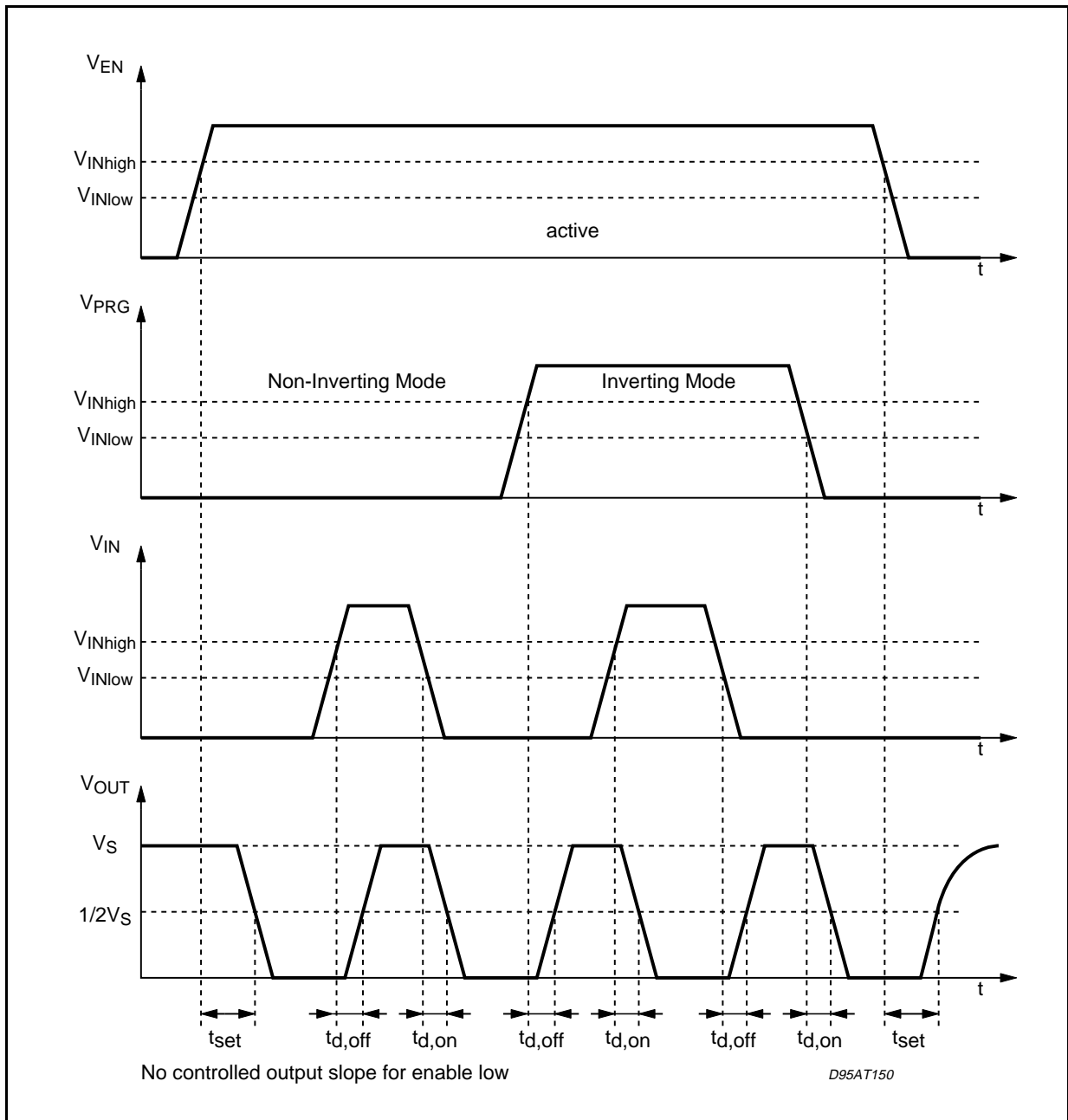

CIRCUIT DESCRIPTION

The L93PI is a quad low side driver for lines, lamps or inductive loads in automotive and industrial applications.

All Inputs are TTL or CMOS compatible. This allows the device to be driven directly by a micro-controller. For the noise immunity, all inputs have a Schmitt-trigger with a hysteresis of typ. 100mV. Each input stage has an input voltage protection from -24V to 45V. The device can be activated with a 'high' signal on ENable input. ENable 'low' switches the device into the sleep mode. In this mode the quiescent current is less than 10µA. A high signal on PRoGramming input changes the signal transfer polarity from noninverting into the inverting mode. Normally this pin is connected to V_S or GND. These pins (PRG and EN) are internally fixed at low status by open input condition. Independent of the PRoGramming input, the OUTput switches off, if the signal INput pin is not connected.

Each output driver has a current limitation of min 0.4A and a separate thermal shut-down. The thermal shut-down deactivates that output which ex-

ceeds Temperature switch off level. About 20K below this temperature threshold the output will be activated again. This means, that each output is able to sink continuously 285mA without activating thermal shut-down at 85°C ambient temperature (SO20). The slew rate of the output is limited to max. 14V/µs to reduce the electromagnetic interference, but not for the enable transfer characteristic (see fig. 1). An integrated active fly-back voltage limitation clamps the output voltage during the flyback phase of inductive loads to typ. 50V. The power DMOS switches ON, if the device is enabled and the OUTput swings below ground. This protection avoids the activation of parasitics inside the power DMOS.

The DIAGnostic is an open drain output. The logic status depends on the PRoGramming pin. If the PRG pin is 'low' the DIAG output becomes low, if the device works correctly.

At thermal shut-down of one channel, disconnected ground or supply voltage the DIAGnostic output becomes high. If the PRG pin is 'high' this output is switched off at normal function and switched on at overtemperature.

DIAGNOSTIC TABLE

Pins	EN	PRG	IN	OUT	DIAG
Normal function	H	L	L	L (on)	L (on)
	H	L	H	H (off)	L (on)
	H	H	L	H (off)	H(off)
	H	H	H	L (on)	H(off)
	L	X	X	H (off)	H(off)
Overtemperature, disconnected ground or supply voltage	H	L	X	H (off) *	H (off)
Overtemperature	H	H	X	H (off) *	L (on)

X = not relevant * selective for each channel at overtemperature

Figure 2: Application circuit for inverting transfer polarity.

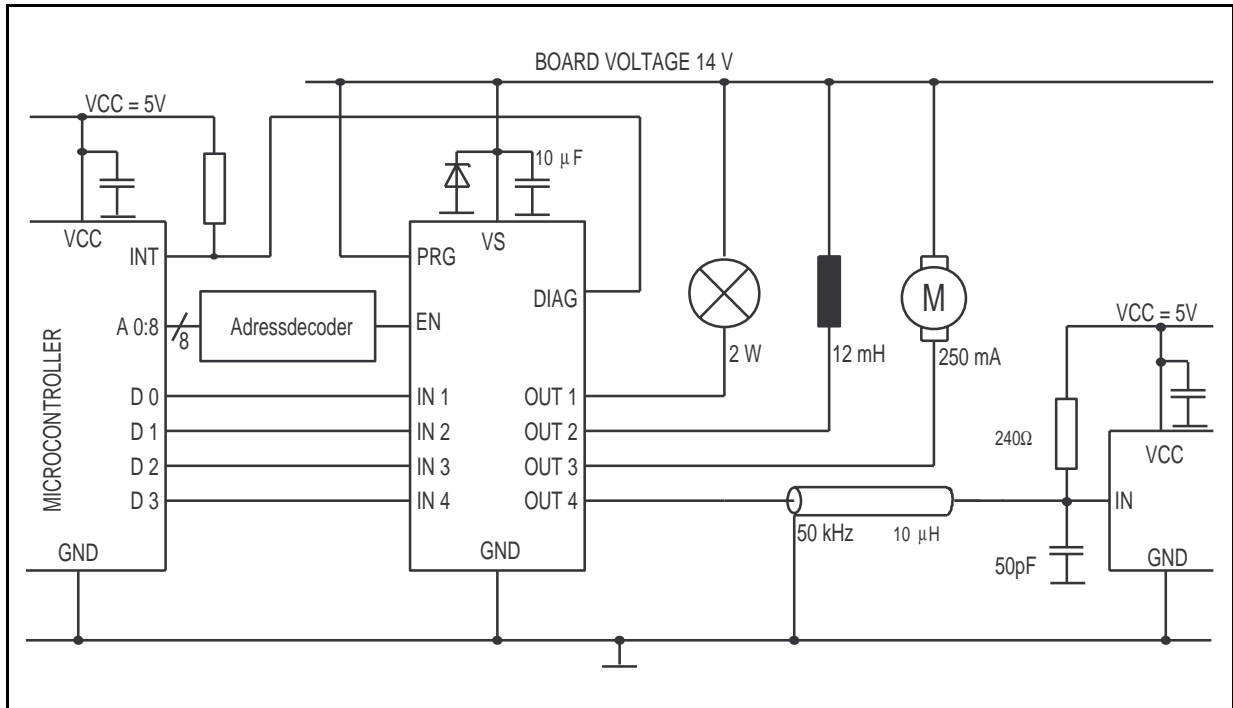

DIM.	mm			inch		
	MIN.	TYP.	MAX.	MIN.	TYP.	MAX.
A	2.35		2.65	0.093		0.104
A1	0.1		0.3	0.004		0.012
B	0.33		0.51	0.013		0.020
C	0.23		0.32	0.009		0.013
D	12.6		13	0.496		0.512
E	7.4		7.6	0.291		0.299
e		1.27			0.050	
H	10		10.65	0.394		0.419
h	0.25		0.75	0.010		0.030
L	0.4		1.27	0.016		0.050
K	0° (min.)8° (max.)					

OUTLINE AND MECHANICAL DATA

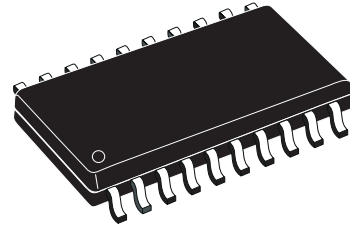

SO20

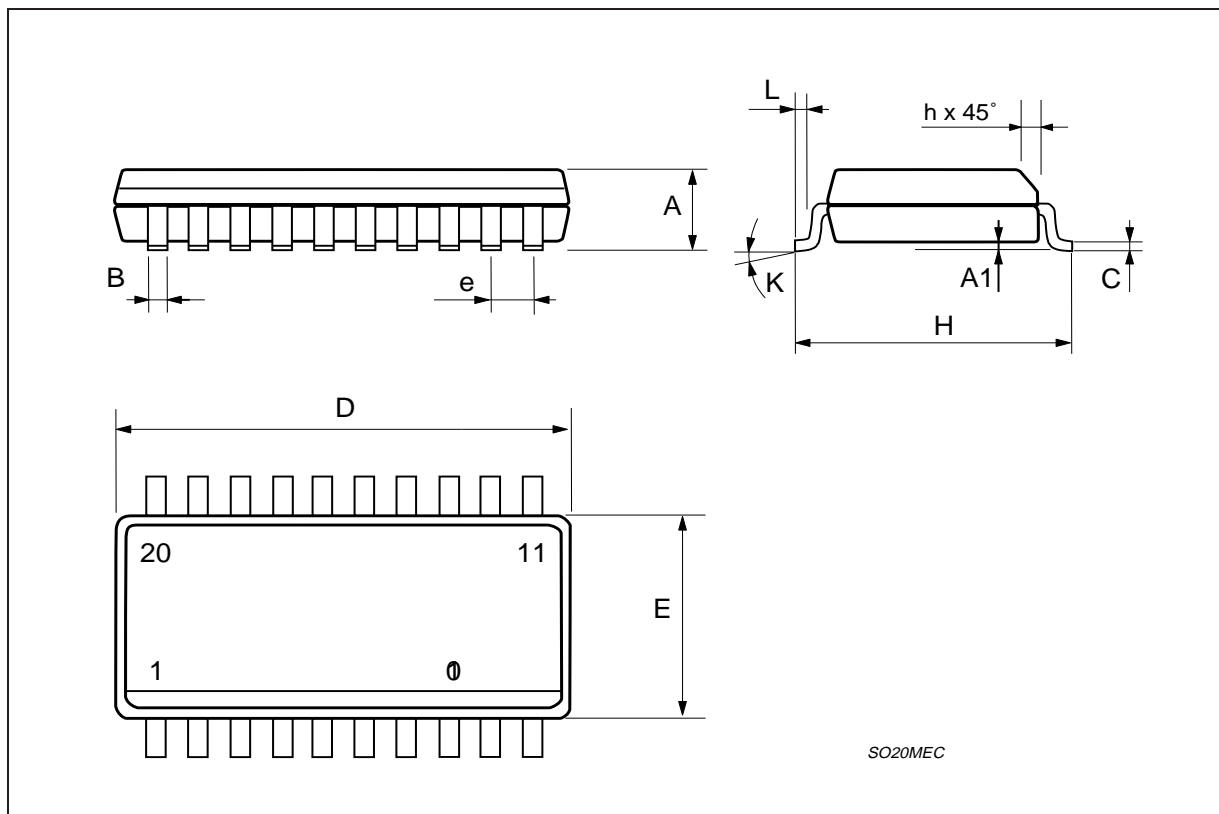

Please Read Carefully:

Information in this document is provided solely in connection with ST products. STMicroelectronics NV and its subsidiaries ("ST") reserve the right to make changes, corrections, modifications or improvements, to this document, and the products and services described herein at any time, without notice.

All ST products are sold pursuant to ST's terms and conditions of sale.

Purchasers are solely responsible for the choice, selection and use of the ST products and services described herein, and ST assumes no liability whatsoever relating to the choice, selection or use of the ST products and services described herein.

No license, express or implied, by estoppel or otherwise, to any intellectual property rights is granted under this document. If any part of this document refers to any third party products or services it shall not be deemed a license grant by ST for the use of such third party products or services, or any intellectual property contained therein or considered as a warranty covering the use in any manner whatsoever of such third party products or services or any intellectual property contained therein.

UNLESS OTHERWISE SET FORTH IN ST'S TERMS AND CONDITIONS OF SALE ST DISCLAIMS ANY EXPRESS OR IMPLIED WARRANTY WITH RESPECT TO THE USE AND/OR SALE OF ST PRODUCTS INCLUDING WITHOUT LIMITATION IMPLIED WARRANTIES OF MERCHANTABILITY, FITNESS FOR A PARTICULAR PURPOSE (AND THEIR EQUIVALENTS UNDER THE LAWS OF ANY JURISDICTION), OR INFRINGEMENT OF ANY PATENT, COPYRIGHT OR OTHER INTELLECTUAL PROPERTY RIGHT.

ST PRODUCTS ARE NOT DESIGNED OR AUTHORIZED FOR USE IN: (A) SAFETY CRITICAL APPLICATIONS SUCH AS LIFE SUPPORTING, ACTIVE IMPLANTED DEVICES OR SYSTEMS WITH PRODUCT FUNCTIONAL SAFETY REQUIREMENTS; (B) AERONAUTIC APPLICATIONS; (C) AUTOMOTIVE APPLICATIONS OR ENVIRONMENTS, AND/OR (D) AEROSPACE APPLICATIONS OR ENVIRONMENTS. WHERE ST PRODUCTS ARE NOT DESIGNED FOR SUCH USE, THE PURCHASER SHALL USE PRODUCTS AT PURCHASER'S SOLE RISK, EVEN IF ST HAS BEEN INFORMED IN WRITING OF SUCH USAGE, UNLESS A PRODUCT IS EXPRESSLY DESIGNATED BY ST AS BEING INTENDED FOR "AUTOMOTIVE, AUTOMOTIVE SAFETY OR MEDICAL" INDUSTRY DOMAINS ACCORDING TO ST PRODUCT DESIGN SPECIFICATIONS. PRODUCTS FORMALLY ESCC, QML OR JAN QUALIFIED ARE DEEMED SUITABLE FOR USE IN AEROSPACE BY THE CORRESPONDING GOVERNMENTAL AGENCY.

Resale of ST products with provisions different from the statements and/or technical features set forth in this document shall immediately void any warranty granted by ST for the ST product or service described herein and shall not create or extend in any manner whatsoever, any liability of ST.

ST and the ST logo are trademarks or registered trademarks of ST in various countries.

Information in this document supersedes and replaces all information previously supplied.

The ST logo is a registered trademark of STMicroelectronics. All other names are the property of their respective owners.

© 2013 STMicroelectronics - All rights reserved

STMicroelectronics group of companies

Australia - Belgium - Brazil - Canada - China - Czech Republic - Finland - France - Germany - Hong Kong - India - Israel - Italy - Japan - Malaysia - Malta - Morocco - Philippines - Singapore - Spain - Sweden - Switzerland - United Kingdom - United States of America

www.st.com



AMEYA360

Components Supply Platform

Authorized Distribution Brand :



Website :

Welcome to visit www.ameya360.com

Contact Us :

➤ Address :

401 Building No.5, JiuGe Business Center, Lane 2301, Yishan Rd
Minhang District, Shanghai , China

➤ Sales :

Direct +86 (21) 6401-6692

Email amall@ameya360.com

QQ 800077892

Skype [ameyasales1](#) [ameyasales2](#)

➤ Customer Service :

Email service@ameya360.com

➤ Partnership :

Tel +86 (21) 64016692-8333

Email mkt@ameya360.com