

NB3N5573DTGEVB

NB3N5573DTGEVB Evaluation Board User's Manual



ON Semiconductor®

<http://onsemi.com>

Device Name: NB3N5573DTG (TSSOP-16)
Board Name: NB35573DTGEVB

EVAL BOARD USER'S MANUAL

Description

The NB3N5573 is a high precision, low phase noise clock generator that supports PCI Express and Ethernet requirements. The device takes a 25 MHz fundamental mode parallel resonant crystal and generates differential HCSL output at 25 MHz, 100 MHz, 125 MHz or 200 MHz clock frequencies.

See datasheet NB3N5573/D (www.onsemi.com). The NB3N5573DTGEVB Evaluation board is designed to provide a flexible and convenient platform to quickly program, evaluate and verify the performance and operation of the NB3N5573DTG TSSOP-16 (Package Case 948F) device under test: With the device removed, this NB3N5573DTGEVB Evaluation board is designed to accept a 16 Lead TSSOP Socket (M&M Specialties, Inc., 1-800-892-8760, www.mmspec.com, M&M #50-000-00809) to permit use as an insertion test fixture.

Board Features

- Crystal mount source, or input external clock source (SMA)
- A TSSOP-16 NB3N5573DTG device is solder mounted or the board may be adapted for insertion testing by adding a TSSOP-16 socket.
- Separate supply connectors for VDD (banana jack and Anvil Clip) and GND (banana jack)

Contents

Description
Board Features
Board Layout Maps
Test and Measurement Setup Procedures
Appendix 1: Pin to Board Connection Information
Appendix 2: Schematic
Appendix 3: Bill of Materials, Lamination Stackup

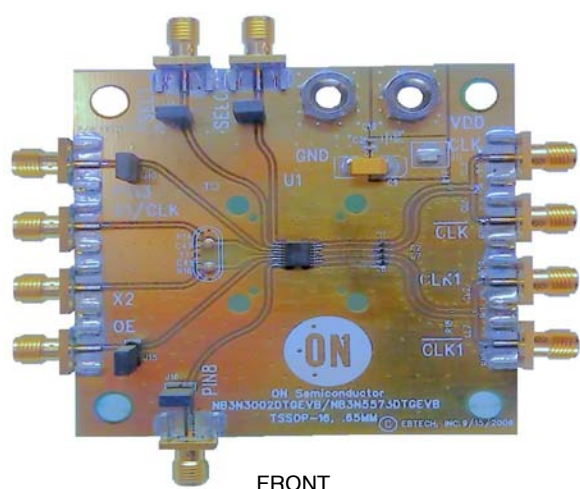

FRONT

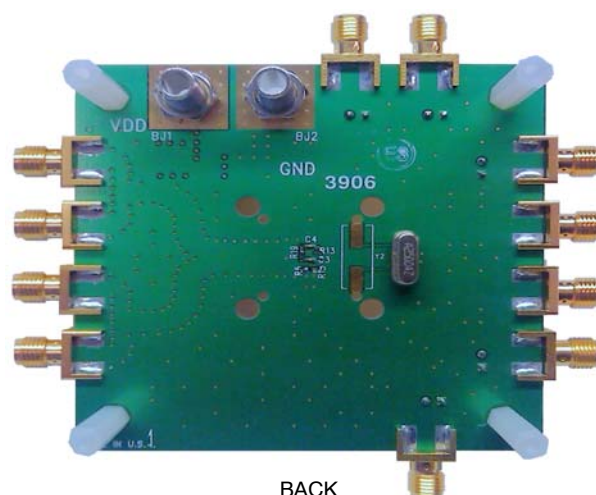

BACK

Figure 1. NB3N5573DTGEVB Evaluation Board

NB3N5573DTGEVB

BOARD LAYOUT

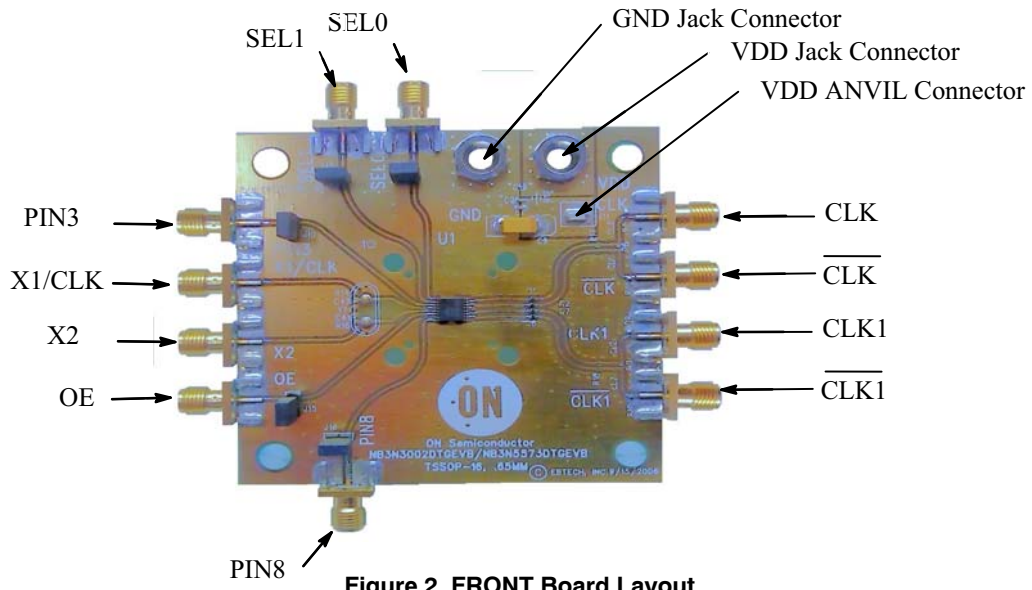

Figure 2. FRONT Board Layout

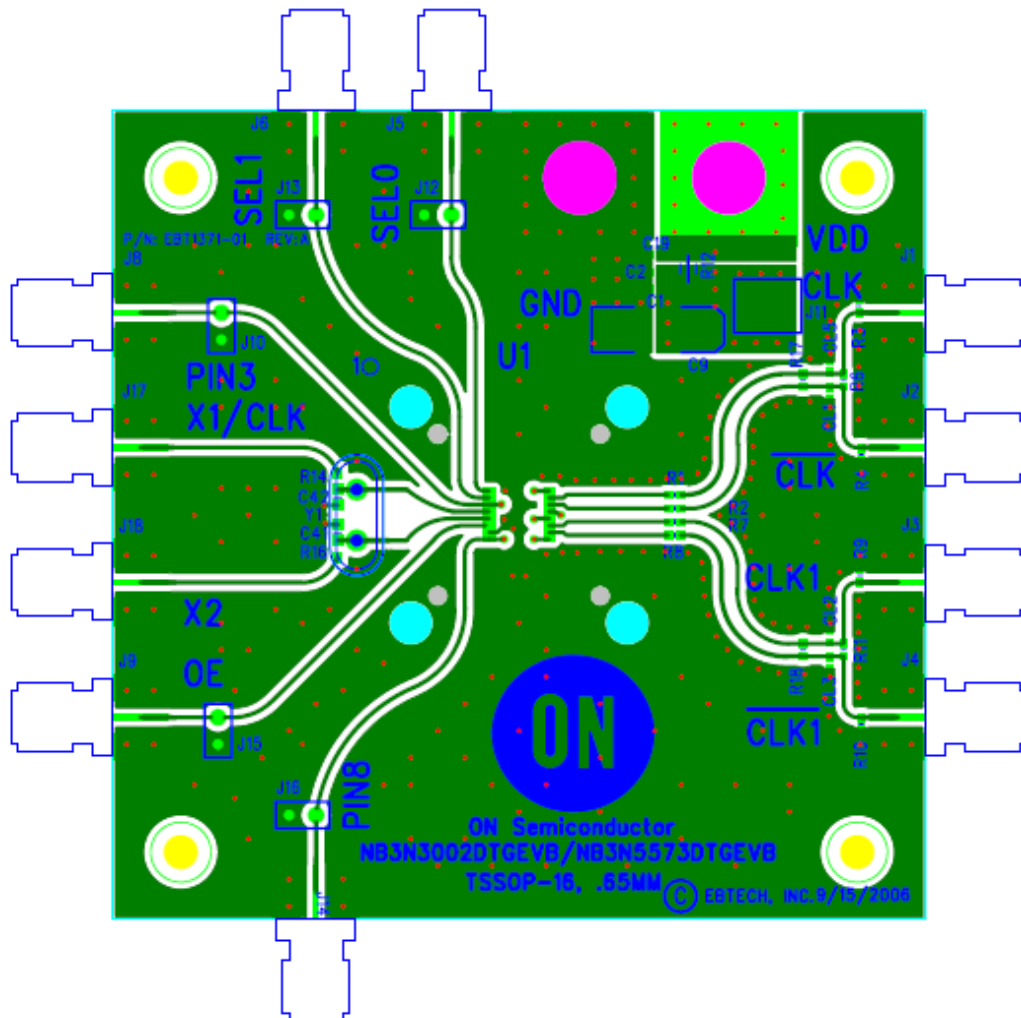

Figure 3. FRONT Layer Design

NB3N5573DTGEVB

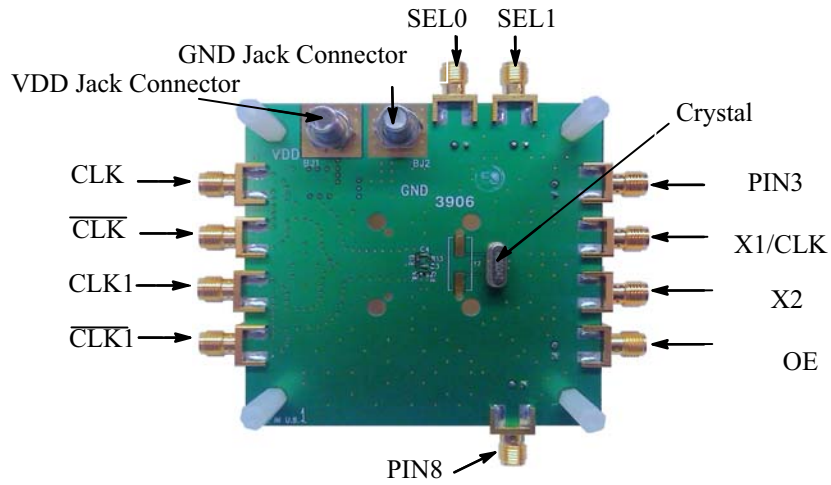

Figure 4. BACK Board Layout

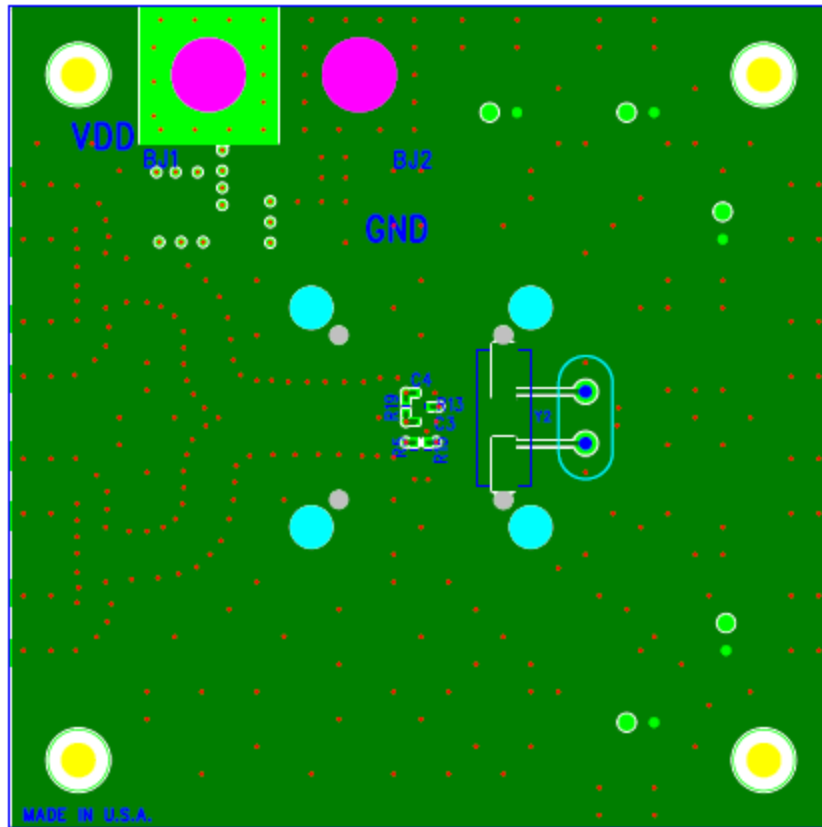

Figure 5. BACK Layer Design

NB3N5573DTGEVB

TEST AND MEASUREMENT SET-UP AND PROCEDURE

Step 1: Equipment

1. Signal Generator: Agilent #33250A or HP8133 (or equivalent)
2. Tektronix TDS8000 Oscilloscope
3. Power Supply: Agilent #6624A or AG6626A DC (or equivalent)
4. Digital Voltmeter: Agilent 34410A or 34401 (or equivalent)
5. Matched Cables (> 20 GHz, SMA connectors): Storm or Semflex (or equivalent)

6. Time Transition Converter: Agilent 14534 250 ps (or equivalent)
7. Phase noise Analyzer: Agilent E5052B (or equivalent)

Step 2: Lab Set-Up Procedure

1. Test Supply Setup:
Board and Device Power Supply Connections are shown in Table 1. VDD (Banana Jack or Anvil Clip test point) and GND (Banana Jack) and may be connected by.

Table 1. POWER SUPPLY CONNECTIONS

Device	Board	Banana Jack	Anvil Clip Test Point	Comments
VDD	VDD	BJ1	J11	
GND	GND	BJ2	J7	DUTGND and SMA GND

SUPPLY (VDD = 3.3 V; GND = 0.0 V' VEE = 0.0 V)

Single supply operation may be accomplished by connecting VDD and GND. HCSL CLK, CLKb, CLK1, and

CLK1b outputs are directly connected to a LOW impedance (50 Ω) module, scope, or probe per Figure 6. Both lines in an HCSL pair must be terminated.

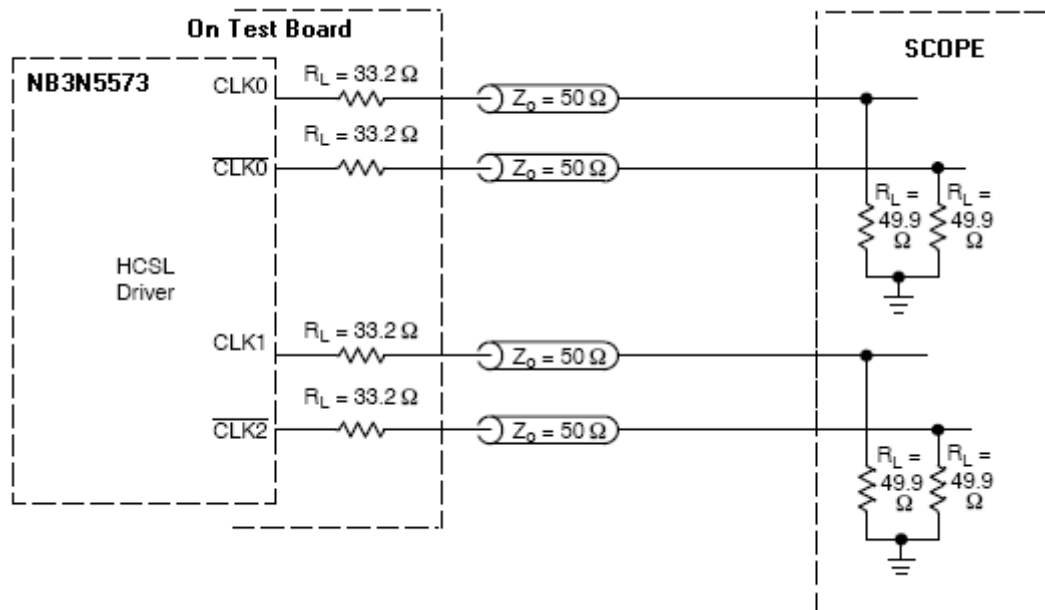

Figure 6. Typical Termination for Output Driver and Device Evaluation

2. Inputs: (see Appendix 1, Device Pin to Board Connection Information)

For a Single Ended input to X1/CLK operation, install a zero ohm jumper resistor at R14. Do not install R16. Do not drive X2. Use a LVCMOS Clock amplitude signal at 25 MHz which satisfies datasheet VIH and VIL to drive X1/CLK. Input tr/tf transition edges should be about 250 ps. Use a TTC (Time transition Converter) such as Agilent 14534 (250 ps) or equivalent, if needed to slow faster edges.

Termination of a signal generator may be accomplished by placing a 50 Ω resistor (to GND) at location C42. The mounted crystal does not need to be removed for Single Ended input operation.

For Crystal operation use a fundamental Parallel Resonant crystal (see Datasheet section on “Recommended Crystal Parameters”) of 25 MHz. The board is supplied with a thru-hole 25 MHz crystal installed, but alternatively has the tabs for a surface mount crystal. The Crystal mount is

NB3N5573DTGEVB

located on the back (underside) of the board and is permanently connected to the device inputs by traces. Crystal load caps should be mounted from each crystal pin to GND (16 74– 20 pF) to fine tune frequency.

Device frequency is selected by LVTTL/LVCMOS level inputs SEL0 and SEL1 per datasheet Table 2. Jumpers J12 (SEL0), J13 (SEL1) may be set to either VDD (HI) or GND (LO), or floated open (HI) to program the output frequency of operation. Jumpers may be removed to drive SEL0/1b directly with spec VIH or VIL levels. Note SEL0/1 inputs will default to VDD when left floating open. High Impedance probes must be used to sense the

LVTTL/LVCMOS input signal levels. Load cap may be added to fine tune frequency such as 15 pF to GND on both crystal pins.

Output current reference pin, IREF (Pin9) has a precision 475 Ω resistor (R5) installed from the output pin to GND to set the output current.

Inputs OE1 and OE2 may be jumpered to VEE (GND) for a LOW level (DISABLED) using J15 (OE1) or J12 (OE2). If floated open (jumper removed), pin will default to a HIGH level (ENABLED). High Impedance probes must be used to sense the signal levels.

APPENDIX 1: DEVICE PIN TO BOARD CONNECTION INFORMATION (see current Datasheet)

Table 2. DEVICE PINS TO BOARD CONNECTION

Device Pin	Device Pin Name	Board Connection	I/O	Description
1	S0	SEL0	LVTTL/LVCMOS Input	Frequency select input 0. Internal pullup resistor to VDD. See datasheet Table 2
2	S1	SEL1	LVTTL/LVCMOS Input	Frequency select input 1. Internal pullup resistor to VDD. See datasheet Table 2
3	NC	PIN3	No Connect	No Connect
4	X1/CLK	X1/CLK	Crystal Interface	Oscillator Input from Crystal. Single ended 25 Mhz LVTTL/LVCMOS Clock Input.
5	X2	X2	Crystal Interface	Oscillator Output to drive Crystal
6	OE	OE	LVTTL/LVCMOS Input	Output Enable Input pin to control CLKx (tri-states CLKx when LOW, open pin defaults to HIGH)
7	GND	GND	Ground Supply	DUT and SMA GND Supply. All Supply pins must be connected for proper operation
8	NC	PIN3	No Connect	No Connect
9	IREF	(-)		(connects Pin 9 through 475 Ω to GND)
10	CLK1b	CLK1b	HCSL Output	HCSL Invert Output
11	CLK1	CLK1	HCSL Output	HCSL True Output
12	VDD	VDD	Positive Supply	Positive Supply pin. All Supply pins must be connected for proper operation.
13	GND	GND	Ground Supply	DUT and SMA GND Supply. All Supply pins must be connected for proper operation
14	CLK0b	CLK0b	HCSL Output	HCSL Invert Output
15	CLK0	CLK0	HCSL Output	HCSL True Output
16	GND	GND	Ground Supply	DUT and SMA GND Supply. All Supply pins must be connected for proper operation

NB3N5573DTGEVB

APPENDIX 2: SCHEMATIC

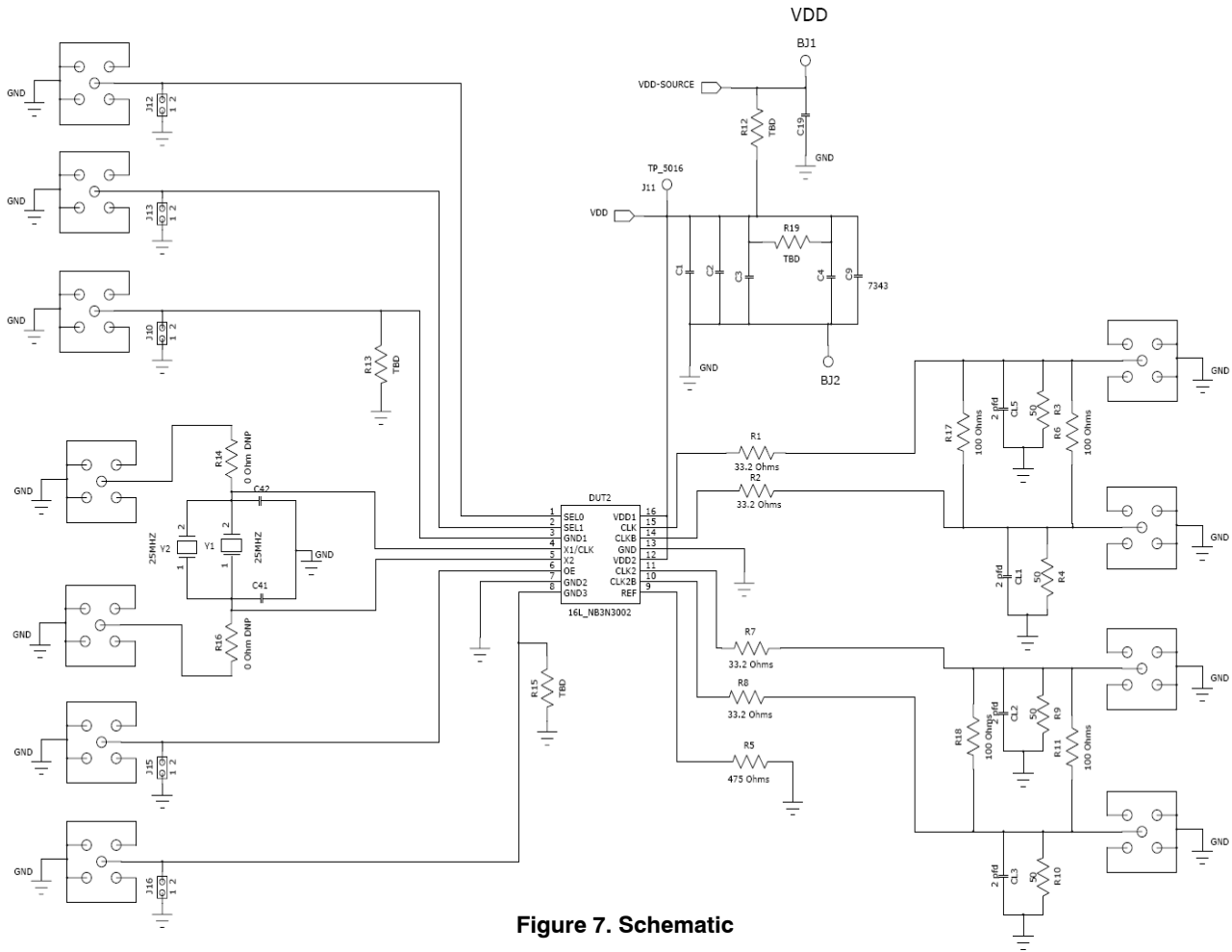

Figure 7. Schematic

NB3N5573DTGEVB

APPENDIX 3: BILL OF MATERIALS, LAMINATION STACKUP, AND ASSEMBLY NOTES

Table 3. BILL OF MATERIAL

Item	Qty	Schematic	Value	Size	MFG	P/N	Description
1	2	BJ1-BJ2			ITT POMONA ELECTRONICS	B-JACK 1/4-32 THREAD	BANANAJACK
2	2	C1,C2	0.1 μ F	0402	Panasonic - ECG	ECJ-DEB1A104K	CAP CERM .1UF 10% 10V X5R
3	2	C3,C4	0.01 μ F	0402	AVX Corporation	04023C103KAT2A	CAP CERM .01UF 10% 25V X7R
4	1	C9	10 μ F	7343	Kemet	T491C106K016AT	CAP TANT 10UF 16V 10% SMD
5	5	J10,J12,J13,J15,J16	2pin		Sullins Electronics Corp	PEC36SACN	CONN HEADER .100 SINGL STR 36 POS
6	5	J10,J12,J13,J15,J16			Sullins Electronics Corp	STC02SYAN	CONN JUMPER SHORTING TIN
7	4	R1,R2,R7,R8	33.2	0402	Panasonic - ECG	ERJ-2RKF33R2X	RES 33.2 Ω 1/16W 1% 0805 SMD
8	4	R3,R4,R9,R10	49.9	0402	YAGEO AMERICA	9C04021A49R8FLHF3	RES 49.9 Ω 1/16W 1% 0805 SMD
9	1	R5	475	0402	Panasonic - ECG	ERJ-2RKF49R9X	RES 475 Ω 1/16W 1% 0805 SMD
10	11	J1-6,J8,J9,J14,J17,J18			Emerson Network Power Connectivity Solutions	142-0701-801	CONN JACK END LAUNCH PCB .187" G
11	1	J11	SMT		KEystone ELECTRONICS	5016	PC TEST POINT COMPACT SMT
12	2	Y1 Socket Pins			Ampere	2-330808-8	CONN SOCKET RCPT .013-.021 30AU
13	U1				On Semiconductor	NB3N5573DT	16 lead Tssop Dut
14	4	Standoff					Nylon Standoff
15	4	Screw					Nylon Screw
16	1	Xtal			ECLIPTEK	ECX-6150-25.000M	XTAL (Do Not Solder)
17	1	SOCKET			M&M	50-000-00809	NOT INSTALLED, Not Provided

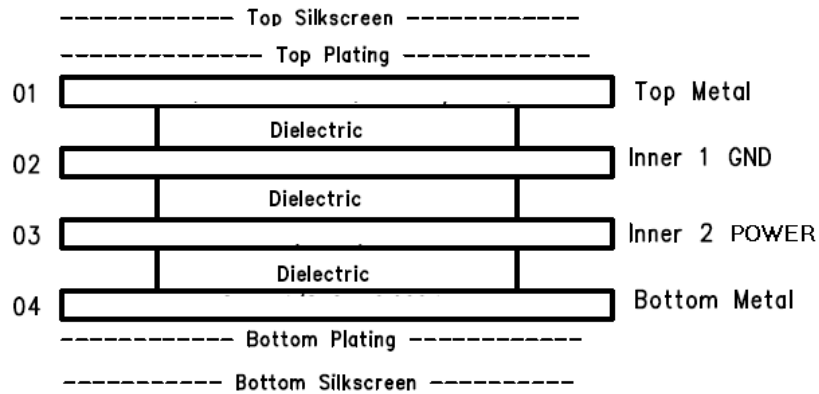



Figure 8. Lamination Stack

NB3N5573DTGEVB

1. Latest revisions shall apply to all specifications.
2. Fabricate PCB in accordance with IPC-A-600; using supplied CAD Data. Board data viewed from primary side (layer 1).
Board shall meet the requirements of UL796 with a flammability rating of 94V-0. Vendors UL logo or designation, date code, and UL rating shall be located in etch on the secondary side of the board. If space is limited, it is permissible to locate markings on secondary legend.
3. Materials: 180 TG FR4 or better, RoHS Compliant
Refer to layer stack-up for copper weight and dielectric thickness.
4. Impedance: Refer to layer stack-up.
5. Finish - .00005" of Hard Gold over .0002" Nickel
6. Soldermask: Color - Green, Type - LPI, Sides - Bottom ONLY.
7. Legend (silkscreen): No legend allowed on exposed lands.
Color - White, permanent, organic, non-conductive epoxy ink.
8. Electrical Test - 100% electrical test required and verified to IPC-356 netlist provided. Not applicable for double sided boards.
9. Warp and twist shall not exceed 10% (.010" per linear inch).
10. Tolerances:
Finished Plated through hole tolerance is +/- .003".
Non-plated through hole tolerance is +/- .001".
Board profile +/- .010".
11. Conductor widths shall be within +/- .001 of supplied artwork (except for impedance signals).
12. Remove all burrs and sharp edges > .015".

ON Semiconductor and  are registered trademarks of Semiconductor Components Industries, LLC (SCILLC). SCILLC reserves the right to make changes without further notice to any products herein. SCILLC makes no warranty, representation or guarantee regarding the suitability of its products for any particular purpose, nor does SCILLC assume any liability arising out of the application or use of any product or circuit, and specifically disclaims any and all liability, including without limitation special, consequential or incidental damages. "Typical" parameters which may be provided in SCILLC data sheets and/or specifications can and do vary in different applications and actual performance may vary over time. All operating parameters, including "Typicals" must be validated for each customer application by customer's technical experts. SCILLC does not convey any license under its patent rights nor the rights of others. SCILLC products are not designed, intended, or authorized for use as components in systems intended for surgical implant into the body, or other applications intended to support or sustain life, or for any other application in which the failure of the SCILLC product could create a situation where personal injury or death may occur. Should Buyer purchase or use SCILLC products for any such unintended or unauthorized application, Buyer shall indemnify and hold SCILLC and its officers, employees, subsidiaries, affiliates, and distributors harmless against all claims, costs, damages, and expenses, and reasonable attorney fees arising out of, directly or indirectly, any claim of personal injury or death associated with such unintended or unauthorized use, even if such claim alleges that SCILLC was negligent regarding the design or manufacture of the part. SCILLC is an Equal Opportunity/Affirmative Action Employer. This literature is subject to all applicable copyright laws and is not for resale in any manner.

PUBLICATION ORDERING INFORMATION

LITERATURE FULFILLMENT:

Literature Distribution Center for ON Semiconductor
P.O. Box 5163, Denver, Colorado 80217 USA
Phone: 303-675-2175 or 800-344-3860 Toll Free USA/Canada
Fax: 303-675-2176 or 800-344-3867 Toll Free USA/Canada
Email: orderlit@onsemi.com

N. American Technical Support: 800-282-9855 Toll Free
USA/Canada
Europe, Middle East and Africa Technical Support:
Phone: 421 33 790 2910
Japan Customer Focus Center
Phone: 81-3-5817-1050

ON Semiconductor Website: www.onsemi.com

Order Literature: <http://www.onsemi.com/orderlit>

For additional information, please contact your local
Sales Representative

AMEYA360

Components Supply Platform

Authorized Distribution Brand :



Website :

Welcome to visit www.ameya360.com

Contact Us :

➤ Address :

401 Building No.5, JiuGe Business Center, Lane 2301, Yishan Rd
Minhang District, Shanghai , China

➤ Sales :

Direct +86 (21) 6401-6692

Email amall@ameya360.com

QQ 800077892

Skype [ameyasales1](#) [ameyasales2](#)

➤ Customer Service :

Email service@ameya360.com

➤ Partnership :

Tel +86 (21) 64016692-8333

Email mkt@ameya360.com